



US00D848405S

(12) **United States Design Patent** (10) **Patent No.:** **US D848,405 S**  
**Bould et al.** (45) **Date of Patent:** **\*\* May 14, 2019**

(54) **WIRELESS REPEATER**

FOREIGN PATENT DOCUMENTS

(71) Applicant: **Hunter Douglas, Inc.**, Pearl River, NY (US)

CN 205196004 U 4/2016  
WO 2016057752 A1 4/2016

(72) Inventors: **Fred Bould**, Menlo Park, CA (US);  
**Jeremy Wolf**, Broomfield, CO (US)

OTHER PUBLICATIONS

(73) Assignee: **Hunter Douglas Inc.**, Pearl River, NY (US)

“Smart Light Bulb + WiFi Repeater = Sengled Boost,” Tracy, Technology News, Feb. 11, 2015.

(Continued)

(\*\*) Term: **15 Years**

*Primary Examiner* — Marie D. Fast Horse

(21) Appl. No.: **29/593,099**

(57) **CLAIM**

(22) Filed: **Feb. 6, 2017**

The ornamental design for a wireless repeater, as shown and described.

(51) **LOC (11) Cl.** ..... **14-03**

(52) **U.S. Cl.**

USPC ..... **D14/240**; D14/358

(58) **Field of Classification Search**

USPC ..... D14/356, 357, 358, 361, 362, 365, 367, D14/370, 388, 432, 434, 203.1, 203.6, D14/204, 240, 242, 299, 125, 129, 130, D14/140, 155, 168, 188, 195, 300, 302, D14/314, 348, 351, 496, 142, 230, 433; D13/103, 107, 108, 123, 152, 162, 162.1, D13/163, 168, 184, 199, 137.1, 137.2, D13/137.3, 139.1, 158, 110; D10/104.1, D10/106.6, 116.1, 61, 64, 75, 106.9; D22/119, 120; D23/355, 364, 366; D26/26, 72, 73, 32, 34, 366, 367  
CPC ... H04W 88/08; H04W 88/085; H04W 88/00; H04W 88/005; H04W 88/02; H04W 88/12; H04W 88/14; H04W 88/16; H04W 88/18;

(Continued)

**DESCRIPTION**

FIG. 1 is a front and left side perspective view of a wireless repeater showing our new design with features illustrated in broken lines for illustrative purposes and thus not constituting a part of the claimed design;  
FIG. 2 is a back and right perspective view of the wireless repeater of FIG. 1;  
FIG. 3 is a left side elevational view of the wireless repeater of FIG. 1;  
FIG. 4 is a right side elevational view of the wireless repeater of FIG. 1;  
FIG. 5 is a front plan view of the wireless repeater of FIG. 1;  
FIG. 6 is a back plan view of the wireless repeater of FIG. 1;  
FIG. 7 is a bottom elevational view of the wireless repeater of FIG. 1; and,  
FIG. 8 is a top elevational view of the wireless repeater of FIG. 1.

The dashed lines in the drawings are environmental and for illustrative purposes only and form no part of the claimed design. The dot-dash lines illustrate boundaries and form no part of the claimed design.

(56) **References Cited**

U.S. PATENT DOCUMENTS

D327,690 S \* 7/1992 Ogawa ..... D14/230  
D338,206 S \* 8/1993 Sawaguchi ..... D14/230  
D343,015 S \* 1/1994 Yuen ..... D26/26

(Continued)

**1 Claim, 7 Drawing Sheets**

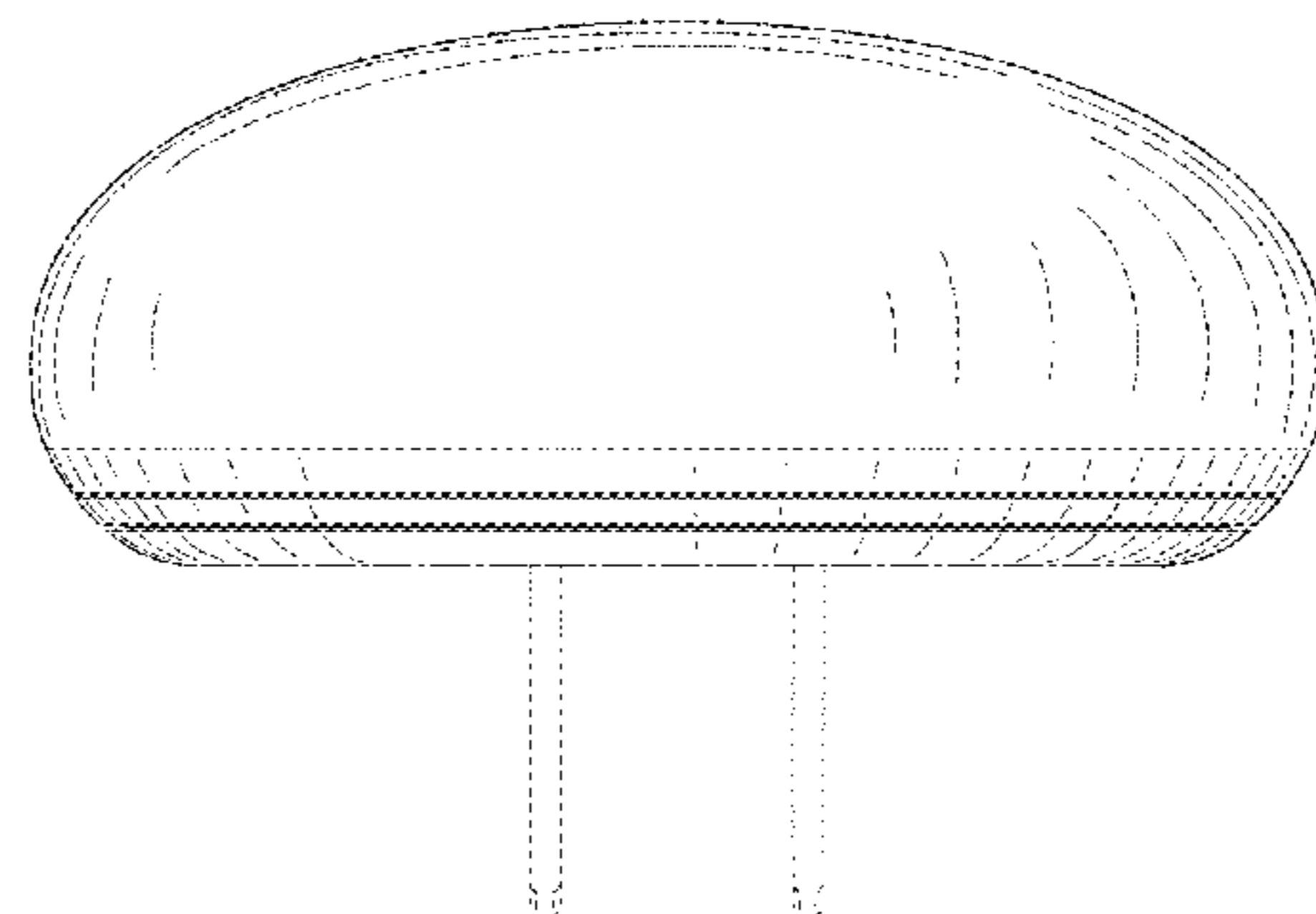
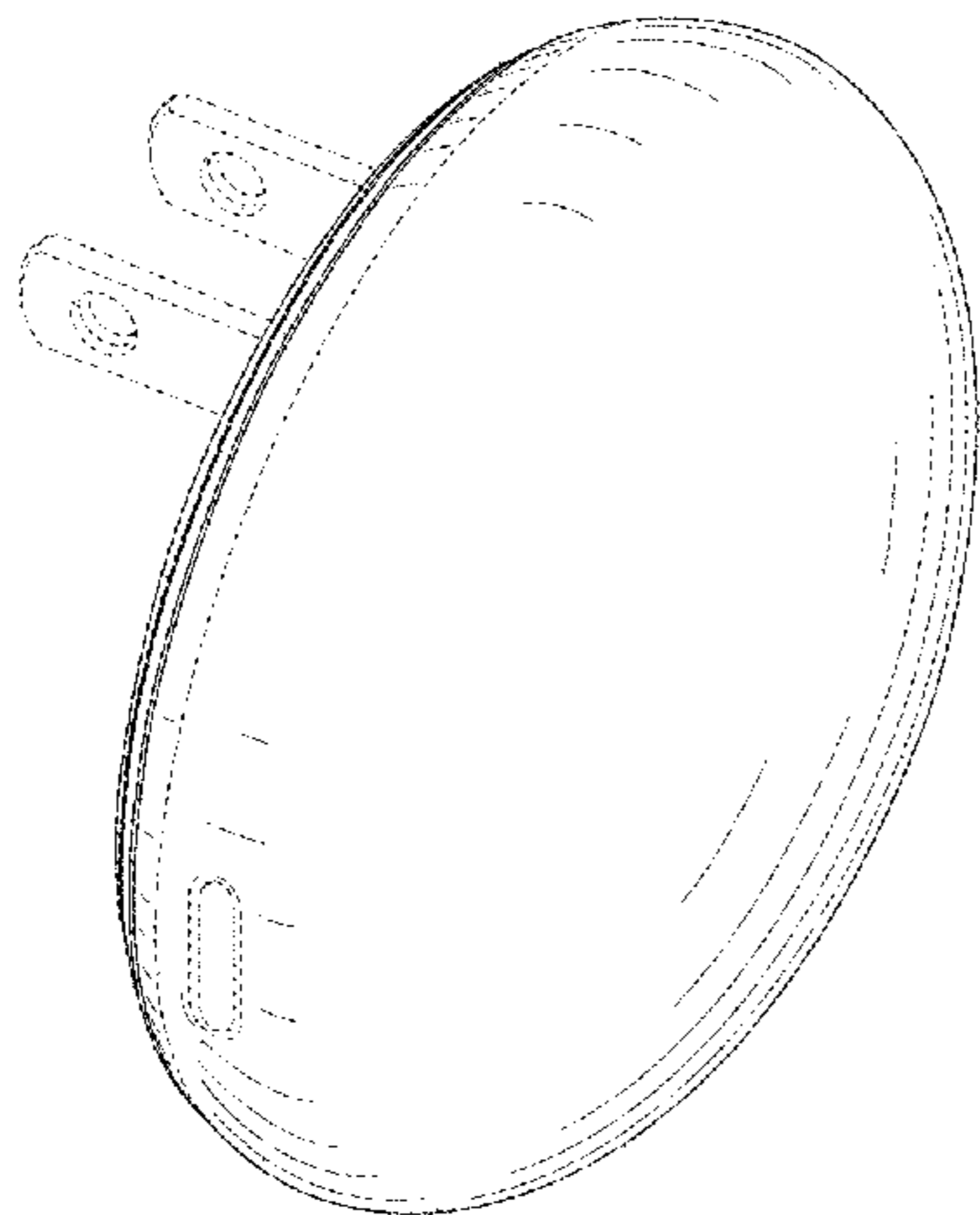

(58) **Field of Classification Search**  
 CPC ..... H04W 4/00; H01Q 1/02; H01Q 1/2291;  
 H01Q 1/246; H04B 1/38  
 See application file for complete search history.

(56) **References Cited**

U.S. PATENT DOCUMENTS

D350,407 S \* 9/1994 Yuen ..... D26/26  
 D391,943 S \* 3/1998 Han ..... D14/356  
 D404,459 S \* 1/1999 Furner ..... D22/119  
 5,905,442 A 5/1999 Mosebrook et al.  
 D425,221 S \* 5/2000 Burns ..... D26/26  
 D428,660 S \* 7/2000 Yuen ..... D26/26  
 D455,507 S \* 4/2002 Liu ..... D26/26  
 D457,667 S \* 5/2002 Piepgras ..... D26/26  
 D458,395 S \* 6/2002 Piepgras ..... D26/26  
 D459,502 S \* 6/2002 Chen ..... D26/26  
 D459,503 S \* 6/2002 Chen ..... D26/26  
 D459,504 S \* 6/2002 Chen ..... D26/26  
 D460,202 S \* 7/2002 Stekelenburg ..... D26/26  
 D476,428 S \* 6/2003 Stekelenburg ..... D26/26  
 D488,166 S \* 4/2004 Daniels ..... D10/104.1  
 D506,404 S \* 6/2005 Kaczmarek ..... D10/104.1  
 D518,030 S \* 3/2006 Lin ..... D14/218  
 D518,819 S \* 4/2006 Gray ..... D14/230  
 7,027,736 B1 4/2006 Mier-Langner et al.  
 D523,569 S \* 6/2006 Funck ..... D26/26  
 D523,972 S \* 6/2006 Chan ..... D26/26  
 D524,458 S \* 7/2006 Chan ..... D26/26  
 D525,375 S \* 7/2006 Funck ..... D26/26  
 7,079,808 B2 7/2006 Striemer  
 7,162,258 B2 1/2007 Beach et al.  
 7,199,701 B2 4/2007 Kates  
 D574,095 S \* 7/2008 Hill ..... D26/26  
 7,446,671 B2 11/2008 Giannopoulos et al.  
 D585,580 S \* 1/2009 Riffel ..... D26/72  
 D585,892 S \* 2/2009 Urban ..... D14/356  
 D595,734 S \* 7/2009 Son ..... D14/203.2  
 D601,282 S \* 9/2009 Howard ..... D26/26  
 7,605,548 B2 10/2009 Yamashita et al.  
 D612,522 S \* 3/2010 Howard ..... D26/26  
 D612,959 S \* 3/2010 Howard ..... D26/26  
 D637,306 S \* 5/2011 Feuerabend ..... D24/215  
 D640,809 S \* 6/2011 Weiser ..... D26/26  
 7,983,613 B2 7/2011 Rappaport  
 D643,412 S \* 8/2011 Brady ..... D14/218  
 8,143,811 B2 3/2012 Shloush et al.  
 D685,790 S \* 7/2013 Tang ..... D14/388  
 D692,171 S \* 10/2013 Randolph ..... D26/67  
 D695,725 S \* 12/2013 Taeger ..... D14/230  
 D700,571 S \* 3/2014 Guccione ..... D13/108  
 D712,572 S \* 9/2014 Dai ..... D26/26  
 8,825,020 B2 9/2014 Mozer et al.  
 8,829,799 B2 9/2014 Recker et al.  
 D714,742 S \* 10/2014 Chambers ..... D13/174

8,891,961 B2 11/2014 Maeda et al.  
 8,942,694 B2 1/2015 Woo  
 D724,583 S \* 3/2015 Ge ..... D14/356  
 D725,088 S \* 3/2015 Kwak ..... D14/240  
 8,975,819 B2 3/2015 Lemmers  
 D731,334 S \* 6/2015 Fiedler ..... D10/70  
 D739,284 S \* 9/2015 Vu ..... D10/103  
 9,167,408 B2 10/2015 Bucci  
 D747,984 S \* 1/2016 Zhao ..... D10/52  
 9,295,144 B2 3/2016 Bora et al.  
 9,408,282 B1 8/2016 Springer  
 D776,820 S \* 1/2017 Rouillac ..... D24/167  
 D788,046 S \* 5/2017 Oksengendler ..... D13/162  
 D790,460 S \* 6/2017 HibmaCronan ..... D13/110  
 D790,461 S \* 6/2017 HibmaCronan ..... D13/110  
 D791,700 S \* 7/2017 Loewen ..... D13/108  
 D795,853 S \* 8/2017 Ngo ..... D14/240  
 D797,665 S \* 9/2017 Champaign ..... D13/108  
 D798,490 S \* 9/2017 Haines ..... D26/104  
 D805,040 S \* 12/2017 Oksengendler ..... D13/162  
 D806,042 S \* 12/2017 Oksengendler ..... D13/162  
 D806,711 S \* 1/2018 Sakaguchi ..... D14/388  
 D809,116 S \* 1/2018 Jones ..... D23/366  
 D809,456 S \* 2/2018 Miller ..... D13/110  
 D810,970 S \* 2/2018 Thompson ..... D26/26  
 D813,212 S \* 3/2018 Nangeroni ..... D14/240  
 D813,852 S \* 3/2018 Ni ..... D14/240  
 D825,539 S \* 8/2018 Lu ..... D14/240  
 2004/0203387 A1 10/2004 Grannan  
 2009/0128262 A1\* 5/2009 Lee ..... H01Q 7/00  
 333/219.1  
 2010/0194207 A1 8/2010 Graham  
 2012/0286940 A1 11/2012 Carmen, Jr. et al.  
 2013/0183042 A1 7/2013 Knapp  
 2014/0070703 A1\* 3/2014 Chen ..... H05B 33/0803  
 315/113  
 2014/0300293 A1 10/2014 Ruan et al.  
 2014/0341585 A1 11/2014 Lee  
 2015/0100173 A1 4/2015 Tubi et al.  
 2015/0257091 A1 9/2015 Zur et al.  
 2015/0332586 A1 11/2015 Hamm et al.  
 2015/0351203 A1 12/2015 Shen et al.  
 2015/0366039 A1 12/2015 Noori et al.  
 2016/0073474 A1 3/2016 Van De Sluis et al.  
 2016/0073479 A1 3/2016 Erchak et al.  
 2016/0132031 A1 5/2016 Kozura et al.  
 2016/0224036 A1\* 8/2016 Baker ..... H04W 4/02

OTHER PUBLICATIONS

HomeSeer, "Product Interfuction: HomeSeer HSM200 Z-Wave Multisensor / Night Light / Indicator Module," Oct. 28, 2014.  
 3SeriesNightLightRepeater—Product Data Sheet (3420), Centralite, Apr. 2016.

\* cited by examiner

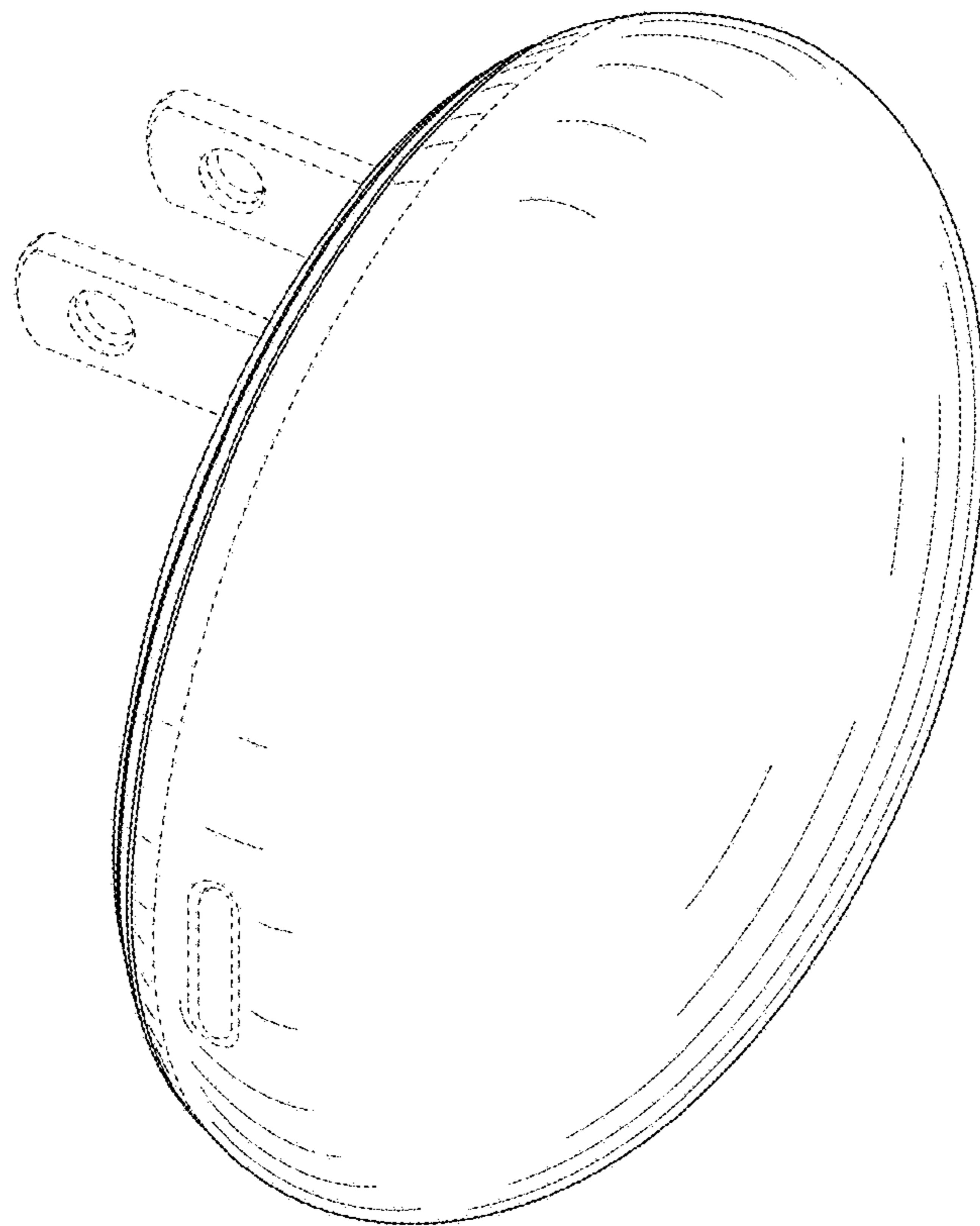

FIG. 1

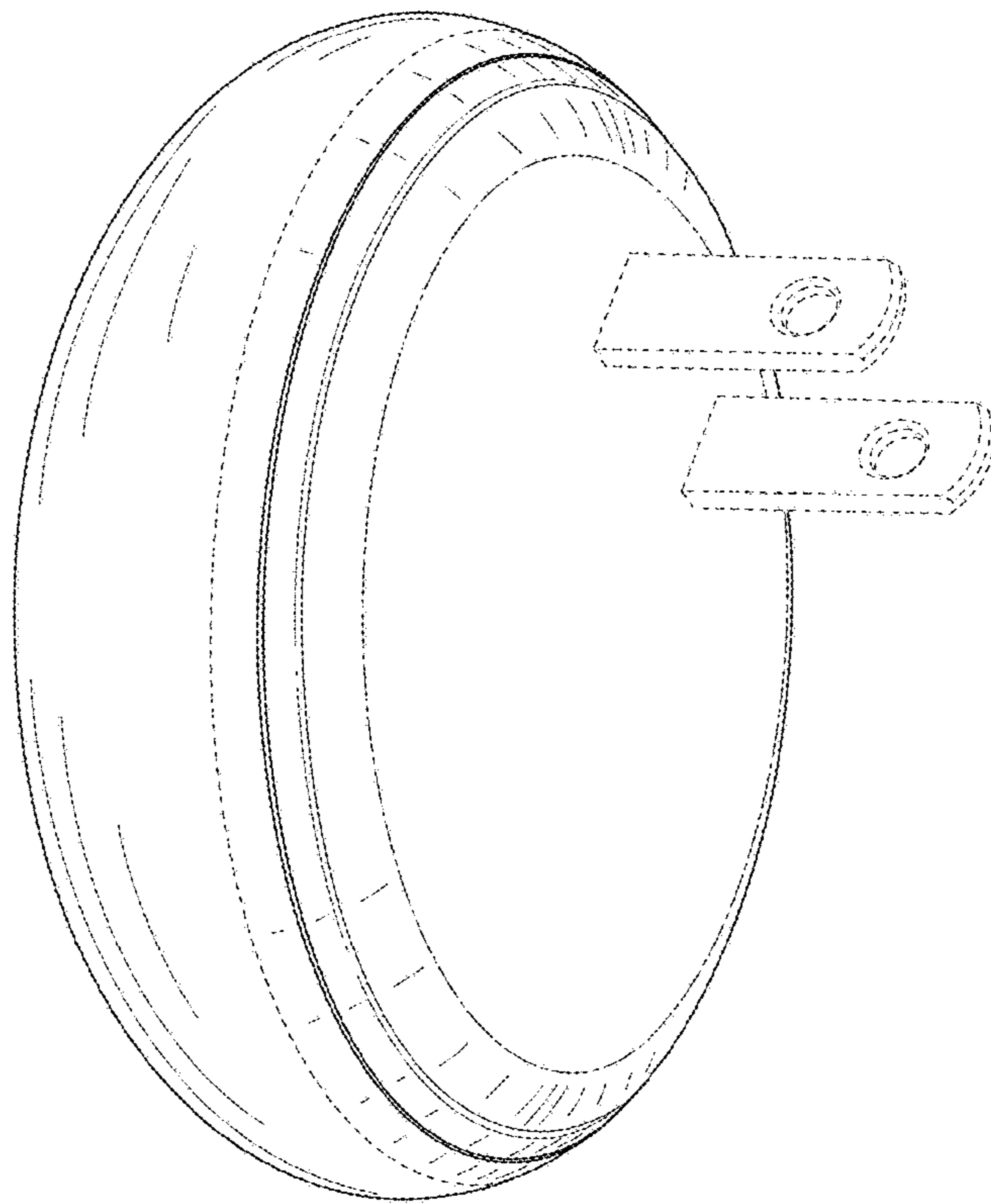

FIG. 2

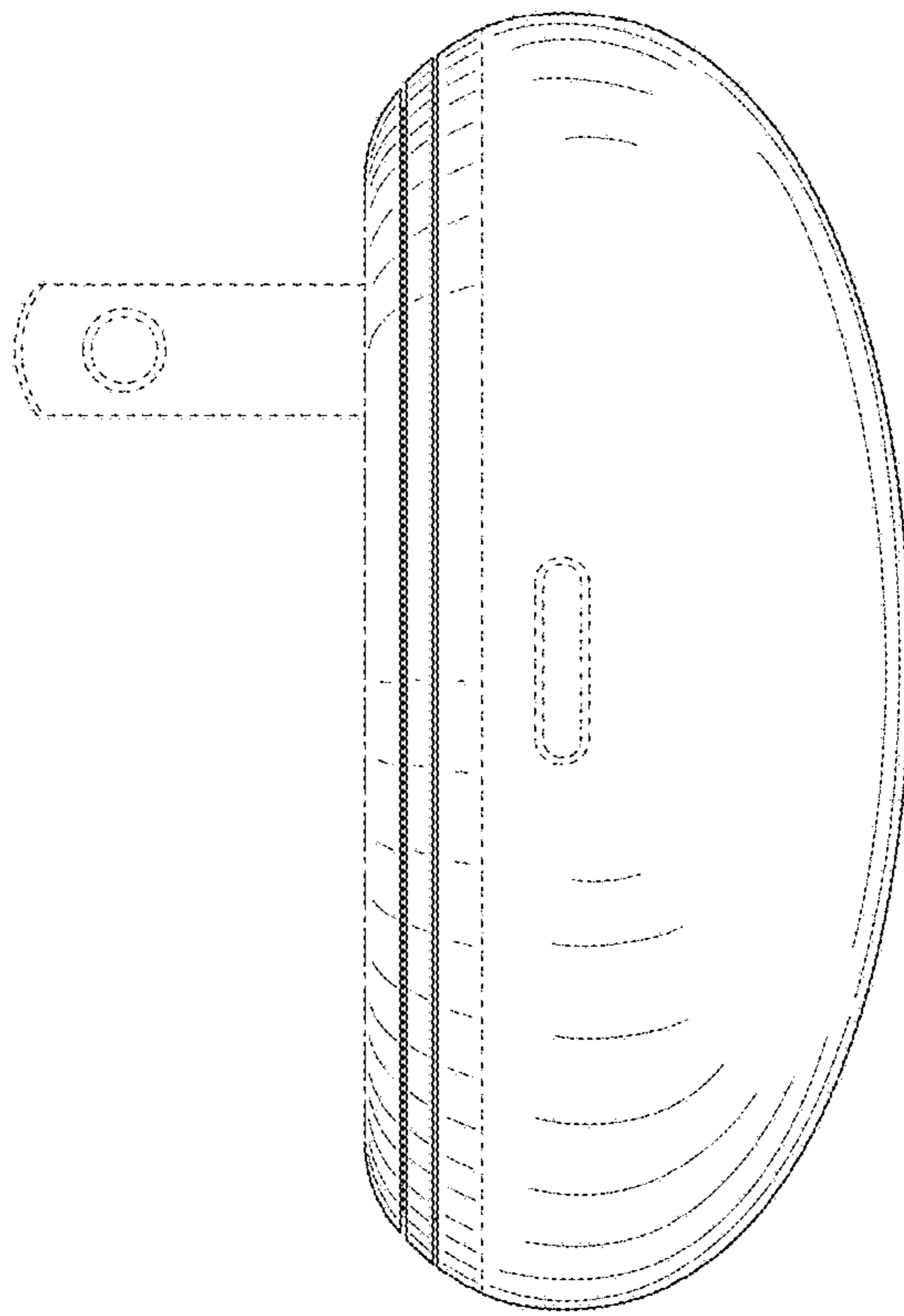

FIG. 3

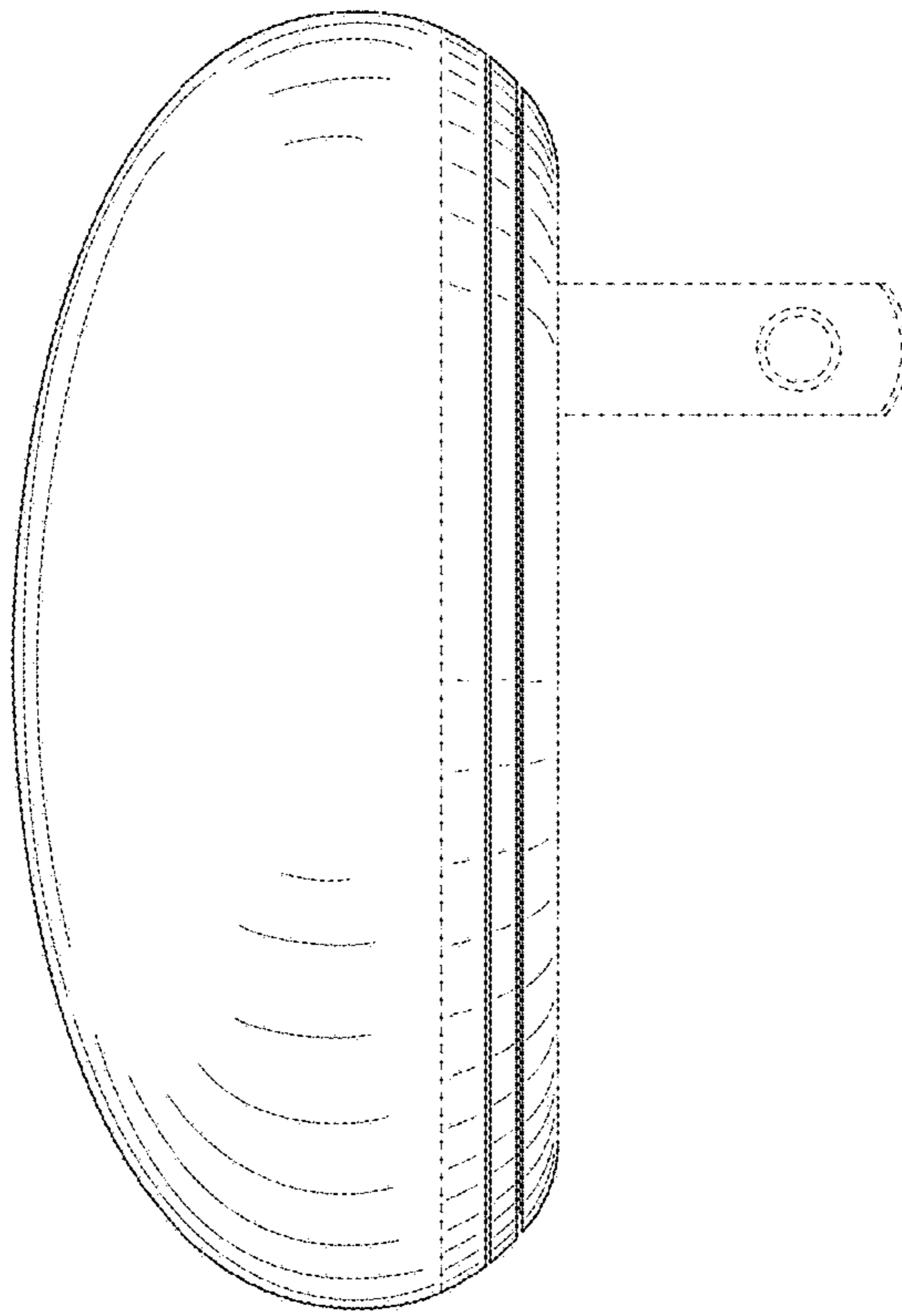

FIG. 4

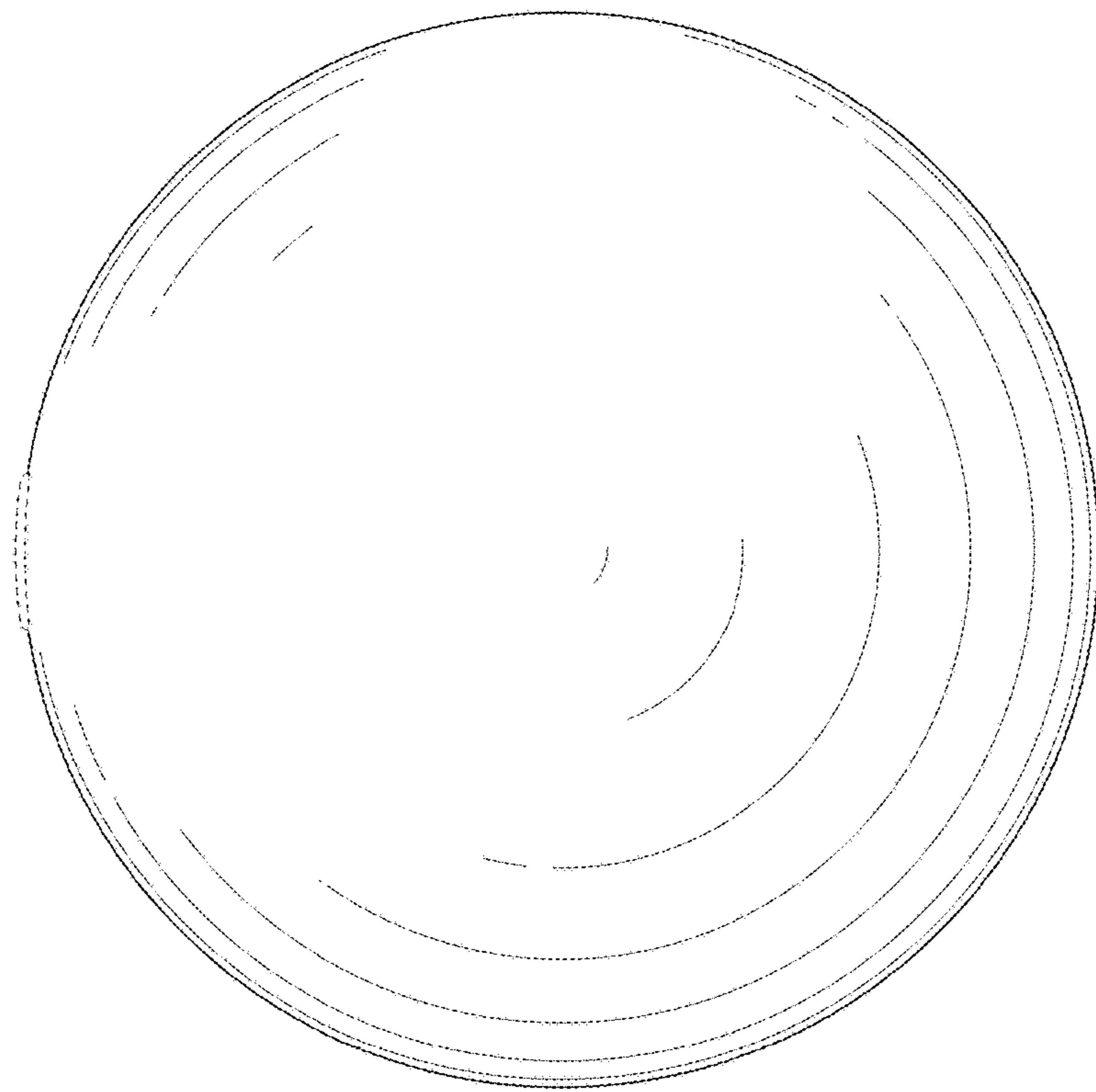

FIG. 5

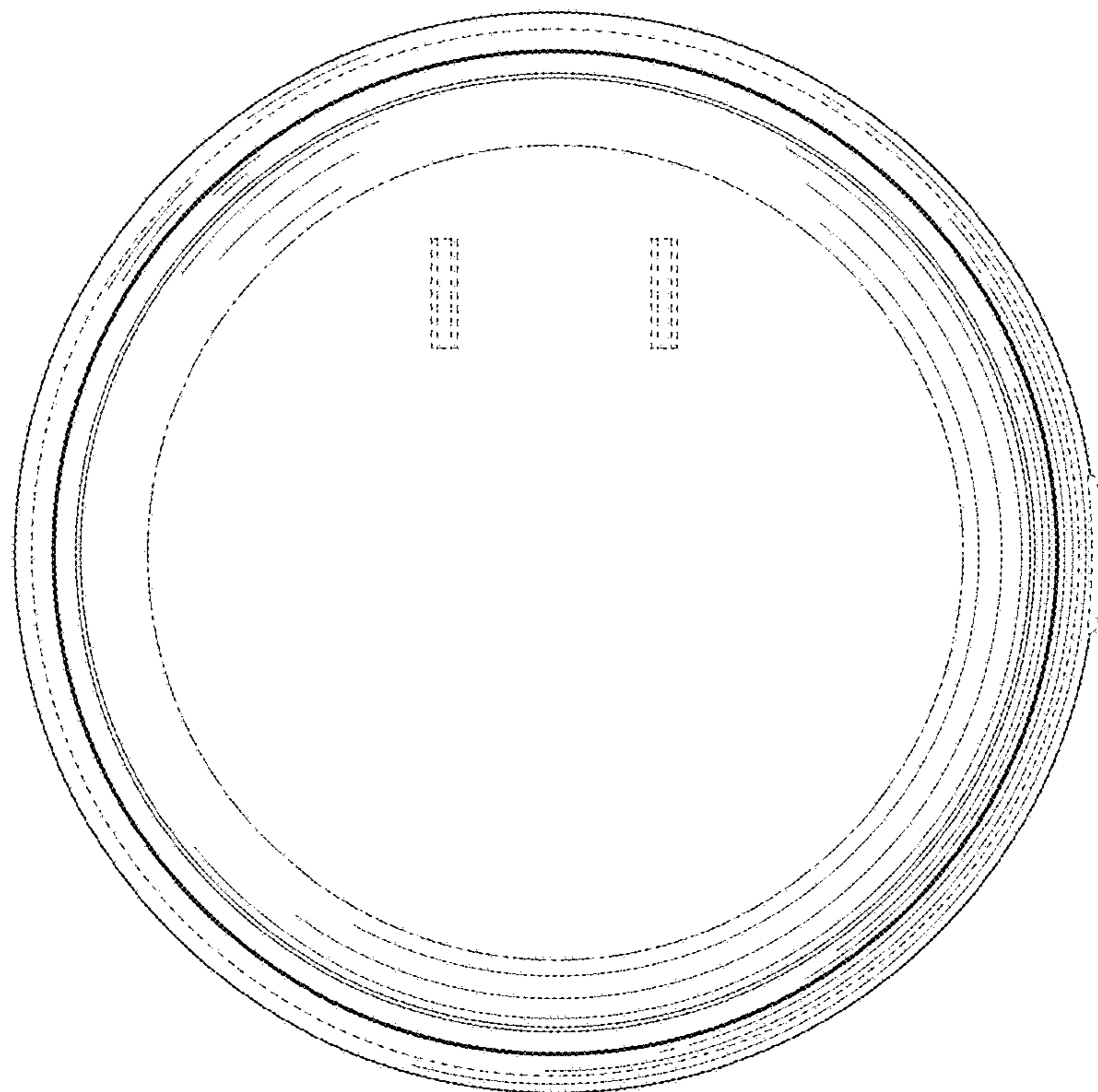

FIG. 6



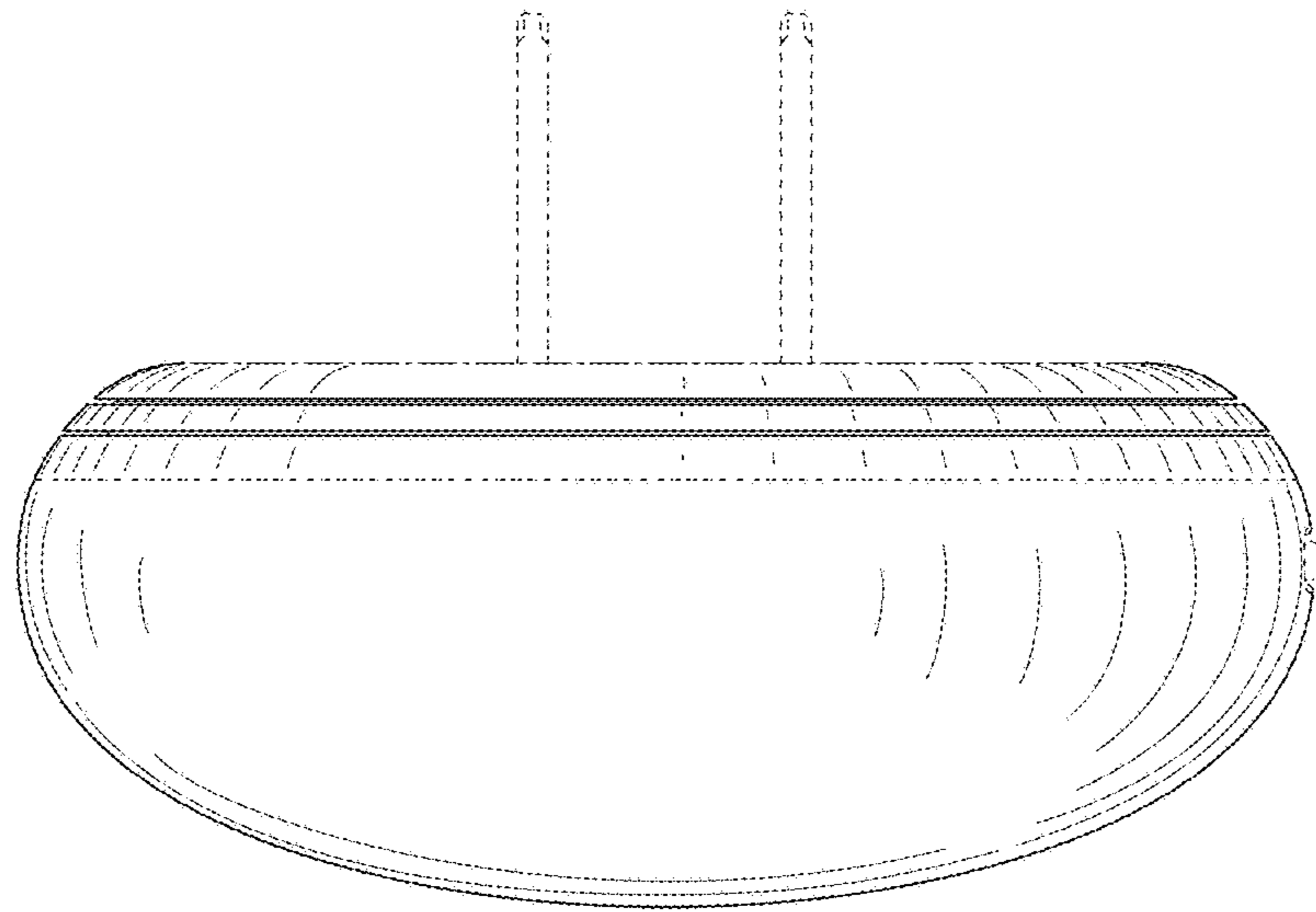

FIG. 7

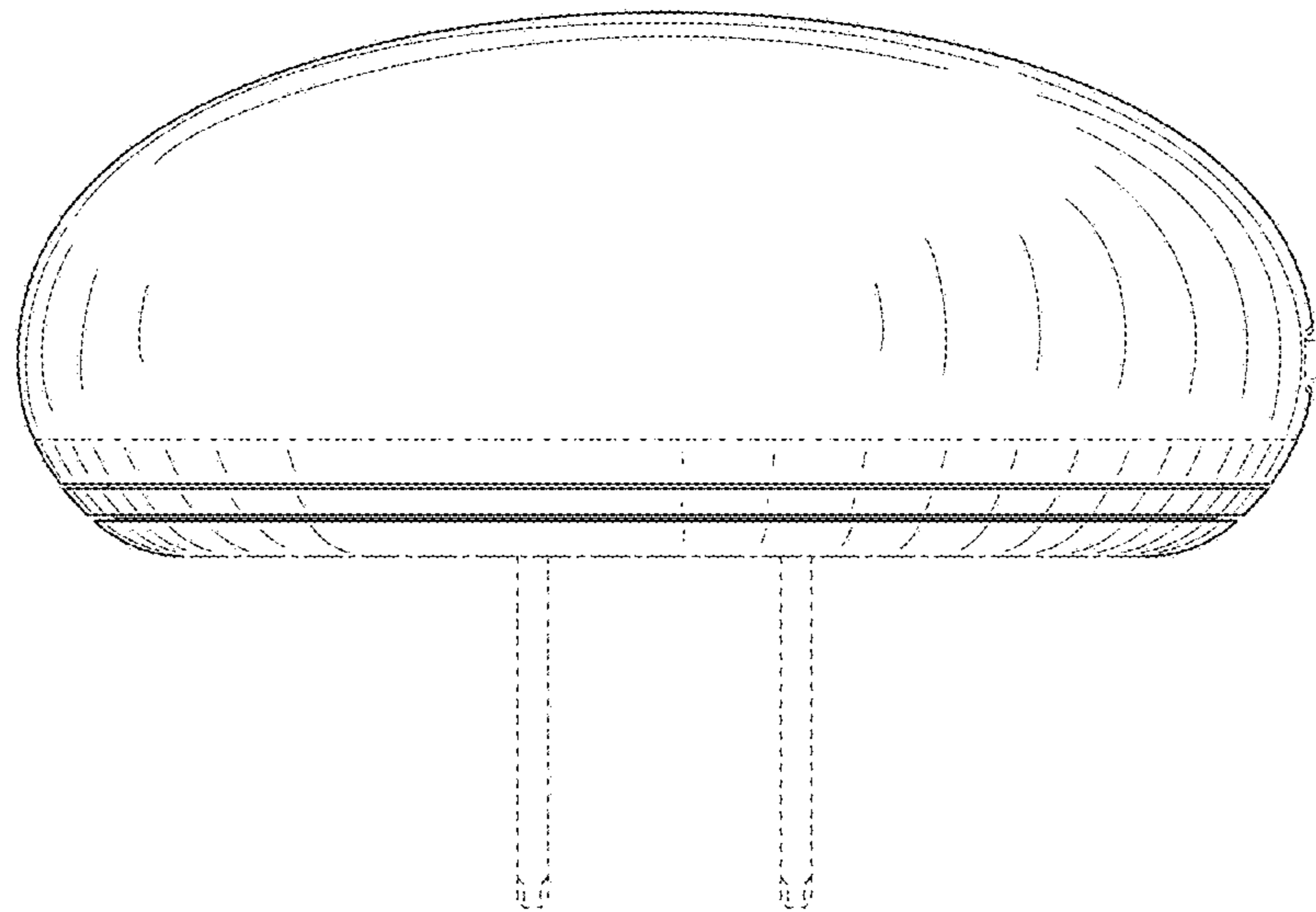

FIG. 8