



US00D848375S

(12) **United States Design Patent** (10) **Patent No.:** **US D848,375 S**
Danesh et al. (45) **Date of Patent:** **** May 14, 2019**

(54) **ELECTRICAL JUNCTION BOX**

(56)

References Cited

(71) Applicant: **DMF, Inc.**, Carson, CA (US)

U.S. PATENT DOCUMENTS

(72) Inventors: **Michael D. Danesh**, Carson, CA (US);
Xinzhi Peng, Downey, CA (US)

2,038,784 A	4/1936	Ghadiali
3,422,261 A	1/1969	McGinty
3,460,299 A	8/1969	Wilson
3,650,046 A	3/1972	Skinner
3,812,342 A	5/1974	Mcnamara
4,088,827 A	5/1978	Kohaut
4,399,497 A	8/1983	Druffel
4,520,435 A	5/1985	Baldwin
4,601,145 A	7/1986	Wilcox
4,723,747 A	2/1988	Karp et al.
4,729,080 A	3/1988	Fremont et al.
4,754,377 A	6/1988	Wenman
4,930,054 A	5/1990	Krebs
5,216,203 A	6/1993	Gower
5,250,269 A	10/1993	Langer et al.
5,382,752 A	1/1995	Reyhan et al.
5,465,199 A	11/1995	Bray et al.
5,544,870 A	8/1996	Kelly et al.
5,562,343 A	10/1996	Chan et al.
5,571,993 A	11/1996	Jones et al.
5,580,158 A	12/1996	Aubrey et al.
5,588,737 A	12/1996	Kusmer
5,603,424 A	2/1997	Bordwell et al.
D381,111 S	7/1997	Lecluze
5,662,413 A	9/1997	Akiyama et al.
D386,277 S	11/1997	Lecluze
D387,466 S	12/1997	Lecluze
5,738,436 A	4/1998	Cummings et al.
5,836,678 A	11/1998	Wright et al.
5,942,726 A	8/1999	Reiker
5,944,412 A	9/1999	Janos et al.
5,975,323 A	11/1999	Turan
6,082,878 A	7/2000	Doubek et al.
6,105,334 A	8/2000	Monson et al.
6,161,910 A	12/2000	Reisenauer et al.
6,170,685 B1	1/2001	Currier
6,174,076 B1	1/2001	Petrakis et al.
6,267,491 B1	7/2001	Parrigin
6,350,043 B1	2/2002	Gloisten
6,364,511 B1	4/2002	Cohen
D461,455 S	8/2002	Forbes
6,474,846 B1	11/2002	Kelmelis et al.
6,491,413 B1	12/2002	Benesohn
6,515,313 B1	2/2003	Ibbetson et al.
6,583,573 B2	6/2003	Bierman
6,585,389 B2	7/2003	Bonazzi
6,600,175 B1	7/2003	Baretz et al.
6,657,236 B1	12/2003	Thibeault et al.

(73) Assignee: **DMF, Inc.**, Carson, CA (US)

(**) Term: **15 Years**

(21) Appl. No.: **29/664,471**

(22) Filed: **Sep. 25, 2018**

Related U.S. Application Data

(63) Continuation of application No. 29/645,941, filed on Apr. 30, 2018, now Pat. No. Des. 833,977, which is a continuation of application No. 29/541,565, filed on Oct. 5, 2015.

(51) **LOC (11) Cl.** **13-03**

(52) **U.S. Cl.**
USPC **D13/152**

(58) **Field of Classification Search**

USPC D13/108, 110, 123, 133, 137.1-137.4,
D13/138.1-138.2, 139.1-139.8, 152-154,
D13/146, 147, 156, 158, 177, 184, 199;
D14/432, 433, 435.1; D8/350-353, 356;
D25/102, 122, 124; D26/74

CPC H01R 11/00; H01R 9/00; H01R 25/00;
H01R 25/006; H01R 13/6675; H01R
13/44; H01R 13/627; H01R 13/447;
H01R 13/73; H01R 13/66; H01R 13/60;
H01R 13/5845; H01R 13/72; H01R
13/46; H01R 31/065; H01R 31/06; H01R
24/28; H01R 27/00; H02J 2007/0062;
H01B 7/2806; F21S 8/02; F21V 23/00;
F21V 23/01; F16J 13/10; F16B 5/02;
F16L 3/12

See application file for complete search history.

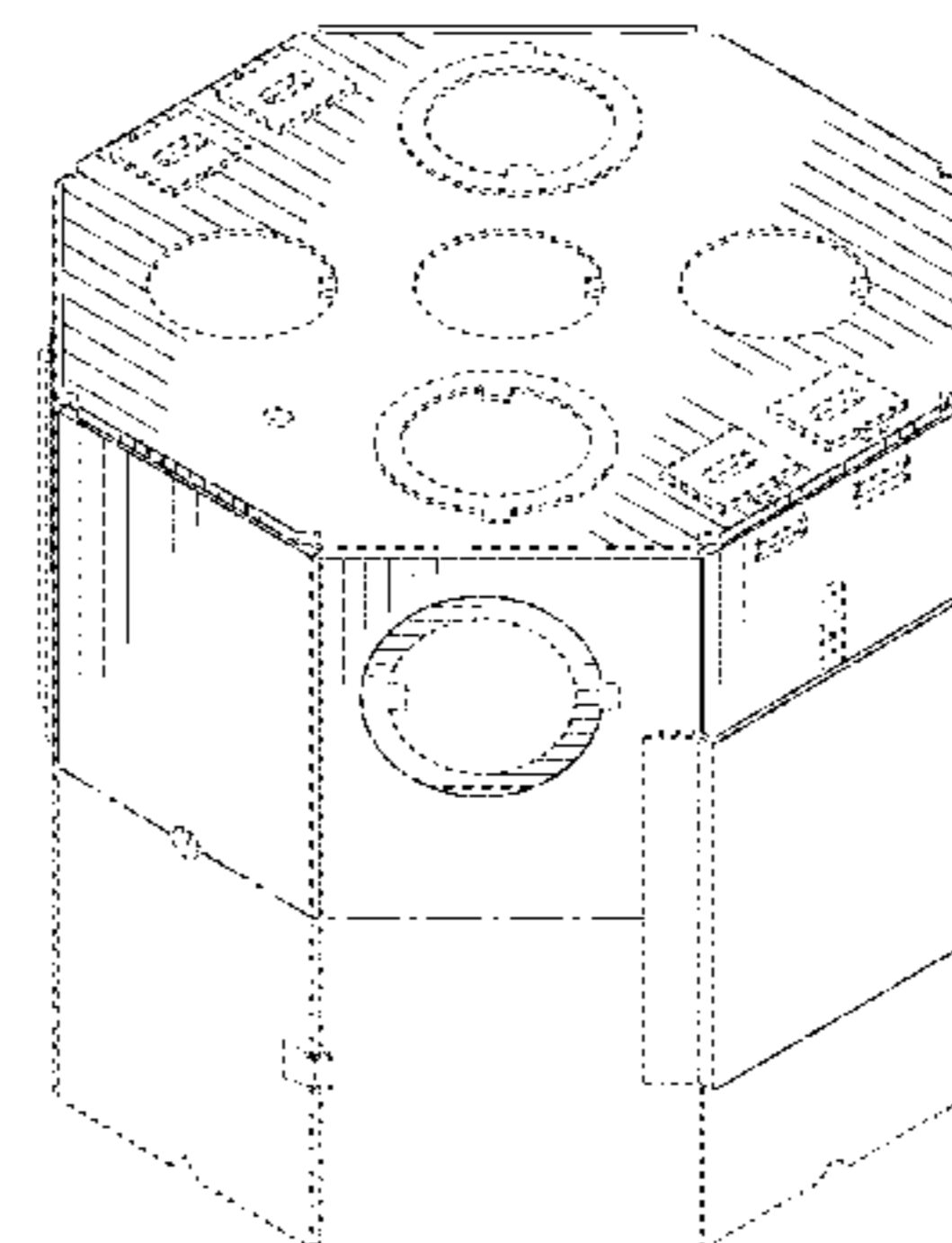
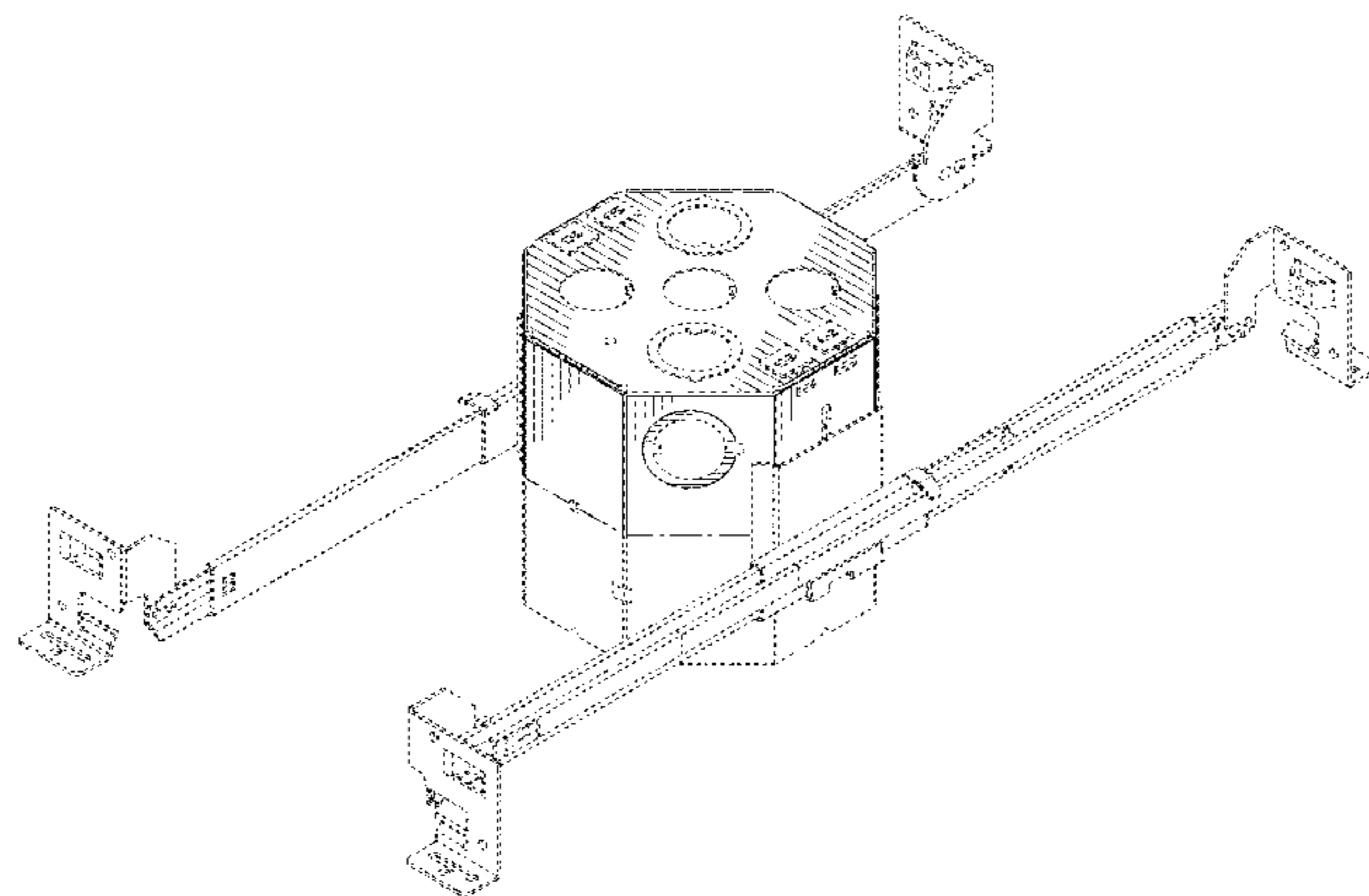

US D848,375 S

6,659,782 B2 *	12/2003	Wu	H01R 31/065 439/131	D639,499 S	6/2011	Choi et al.	
D488,583 S	4/2004	Benghozi		7,959,332 B2	6/2011	Tickner et al.	
6,719,438 B2	4/2004	Sevack et al.		7,967,480 B2	6/2011	Pickard et al.	
6,758,578 B1	7/2004	Chou		D642,317 S	7/2011	Rashidi	
6,777,615 B1	8/2004	Gretz		7,972,035 B2	7/2011	Boyer	
6,906,352 B2	6/2005	Edmond et al.		7,972,043 B2	7/2011	Schutte	
D509,314 S	9/2005	Rashidi		D643,970 S	8/2011	Kim et al.	
6,948,829 B2	9/2005	Verdes et al.		D646,011 S	9/2011	Rashidi	
6,958,497 B2	10/2005	Emerson et al.		8,038,113 B2	10/2011	Fryzek et al.	
6,964,501 B2	11/2005	Ryan		D648,476 S	11/2011	Choi et al.	
D516,235 S	2/2006	Rashidi		D648,477 S	11/2011	Kim et al.	
7,064,269 B2	6/2006	Smith		D650,115 S	12/2011	Kim et al.	
D528,673 S	9/2006	Maxik et al.		8,070,328 B1	12/2011	Knoble et al.	
D531,740 S	11/2006	Maxik		8,096,670 B2	1/2012	Trott	
D532,532 S	11/2006	Maxik		D654,205 S	2/2012	Rashidi	
7,186,008 B2	3/2007	Patti		D656,263 S	3/2012	Ogawa et al.	
7,190,126 B1	3/2007	Paton		8,142,057 B2	3/2012	Roos et al.	
7,211,833 B2	5/2007	Slater, Jr. et al.		8,142,208 B2 *	3/2012	Ruffner	H01R 13/4534 439/105
7,213,940 B1	5/2007	Van De Ven et al.		D657,314 S *	4/2012	Ruffner	D13/139.1
D547,889 S	7/2007	Huang		8,152,334 B2	4/2012	Krogman	
D553,267 S	10/2007	Yuen		8,157,578 B2 *	4/2012	Lee	H01R 31/06 439/172
7,297,870 B1	11/2007	Sartini		D658,788 S	5/2012	Dudik et al.	
7,312,474 B2	12/2007	Emerson et al.		D658,802 S	5/2012	Chen	
7,320,536 B2	1/2008	Petrakis et al.		D659,862 S	5/2012	Tsai	
D561,372 S	2/2008	Yan		D659,879 S	5/2012	Rashidi	
D561,373 S	2/2008	Yan		D660,814 S	5/2012	Wilson	
7,335,920 B2	2/2008	Denbaars et al.		8,182,116 B2	5/2012	Zhang et al.	
7,347,580 B2	3/2008	Blackman et al.		8,197,273 B1 *	6/2012	Lee	H01R 31/06 439/172
D570,012 S	5/2008	Huang		8,201,968 B2	6/2012	Maxik et al.	
7,374,308 B2	5/2008	Sevack et al.		D663,058 S	7/2012	Pan	
D570,504 S	6/2008	Maxik et al.		D663,466 S	7/2012	Rashidi	
D570,505 S	6/2008	Maxik et al.		D664,274 S	7/2012	de Visser et al.	
7,399,104 B2	7/2008	Rappaport		D664,705 S	7/2012	Kong et al.	
D578,677 S	10/2008	Huang		8,215,805 B2	7/2012	Cogliano et al.	
7,431,482 B1	10/2008	Morgan et al.		8,220,970 B1	7/2012	Khazi et al.	
7,445,513 B1 *	11/2008	Lee	H01R 31/06 439/131	8,226,270 B2	7/2012	Yamamoto et al.	
7,446,345 B2	11/2008	Emerson et al.		D667,155 S	9/2012	Rashidi	
7,473,005 B2	1/2009	O'Brien		8,262,255 B1	9/2012	Rashidi	
7,488,097 B2	2/2009	Reisenauer et al.		D668,809 S	10/2012	Rashidi	
7,503,145 B2	3/2009	Newbold et al.		D669,198 S	10/2012	Qui	
7,524,089 B2	4/2009	Park		D669,199 S	10/2012	Chuang	
D591,894 S	5/2009	Flank		D669,433 S *	10/2012	Lee	D13/110
7,534,989 B2	5/2009	Suehara et al.		D669,620 S	10/2012	Rashidi	
7,566,154 B2	7/2009	Gloisten et al.		8,277,090 B2	10/2012	Fryzek et al.	
D599,040 S	8/2009	Alexander et al.		8,308,322 B2	11/2012	Santiago et al.	
D600,836 S	9/2009	Hanley et al.		8,313,350 B2 *	11/2012	Lee	H01R 31/06 439/172
7,588,359 B2	9/2009	Coushaine et al.		D673,869 S	1/2013	Yu	
7,592,583 B2	9/2009	Page et al.		D676,263 S	2/2013	Birke	
7,625,105 B1	12/2009	Johnson		8,376,593 B2	2/2013	Bazydola et al.	
7,628,513 B2	12/2009	Chiu		8,382,493 B2 *	2/2013	Ruffner	H01R 27/00 439/105
7,651,238 B2	1/2010	O'Brien		D677,417 S	3/2013	Rashidi	
7,654,705 B2	2/2010	Czech et al.		D677,634 S	3/2013	Korcz et al.	
D611,650 S	3/2010	Broekhoff		D679,047 S	3/2013	Tickner et al.	
7,670,021 B2	3/2010	Chou		8,403,533 B1	3/2013	Paulsel	
7,677,766 B2	3/2010	Boyer		8,403,541 B1	3/2013	Rashidi	
7,692,182 B2	4/2010	Bergmann et al.		D681,259 S	4/2013	Kong	
7,704,763 B2	4/2010	Fujii et al.		8,408,759 B1	4/2013	Rashidi	
D616,118 S	5/2010	Thomas et al.		D683,063 S	5/2013	Lopez et al.	
7,722,208 B1	5/2010	Dupre et al.		D683,890 S	6/2013	Lopez et al.	
7,722,227 B2	5/2010	Zhang et al.		D684,269 S	6/2013	Wang et al.	
7,748,887 B2	7/2010	Zampini, II et al.		D684,719 S	6/2013	Rashidi	
7,766,518 B2	8/2010	Piegras et al.		D685,118 S	6/2013	Rashidi	
7,769,192 B2	8/2010	Takagi et al.		D685,120 S	6/2013	Rashidi	
7,771,082 B2	8/2010	Peng		8,454,204 B1	6/2013	Chang et al.	
7,771,094 B2	8/2010	Goode		D685,507 S	7/2013	Sun	
D623,595 S *	9/2010	Ruffner	D13/110	D687,586 S	8/2013	Rashidi	
D624,692 S	9/2010	Mackin et al.		D687,587 S	8/2013	Rashidi	
D625,847 S	10/2010	Maglica		D687,588 S	8/2013	Rashidi	
D625,876 S	10/2010	Chen et al.		D687,980 S	8/2013	Gravelly et al.	
D627,727 S	11/2010	Alexander et al.		D688,405 S	8/2013	Kim et al.	
7,828,465 B2	11/2010	Roberge et al.		D690,049 S	9/2013	Rashidi	
7,871,184 B2	1/2011	Peng		D690,864 S	10/2013	Rashidi	
D633,224 S	2/2011	Lee		D690,865 S	10/2013	Rashidi	
D636,903 S	4/2011	Torenbeek		D690,866 S	10/2013	Rashidi	
D637,339 S	5/2011	Hasan et al.					
D637,340 S	5/2011	Hasan et al.					
7,950,832 B2	5/2011	Tanaka et al.					

US D848,375 S

D691,314 S	10/2013	Rashidi	9,599,315 B1	3/2017	Harpenau et al.
D691,315 S	10/2013	Samson	9,605,910 B2	3/2017	Swedberg et al.
D691,763 S	10/2013	Hand et al.	D785,228 S	4/2017	Guzzini
8,550,669 B2	10/2013	Macwan et al.	D786,472 S	5/2017	Redfern
D693,043 S	11/2013	Schmalfuss et al.	D786,474 S	5/2017	Fujisawa
D693,517 S	11/2013	Davis	D788,330 S	5/2017	Johnson et al.
D694,456 S	11/2013	Rowlette, Jr. et al.	D790,102 S	6/2017	Guzzini
8,573,816 B2	11/2013	Negley et al.	9,673,597 B2	6/2017	Lee
D695,441 S	12/2013	Lui et al.	D791,711 S	7/2017	Holton
D696,446 S	12/2013	Huh	9,702,516 B1	7/2017	Vasquez et al.
D696,447 S	12/2013	Huh	9,791,111 B1	10/2017	Huang et al.
D696,448 S	12/2013	Huh	9,803,839 B2	10/2017	Visser et al.
8,602,601 B2	12/2013	Khazi et al.	D805,479 S *	12/2017	Lin D13/137.2
D698,067 S	1/2014	Rashidi	D805,660 S	12/2017	Creasman et al.
D698,068 S	1/2014	Rashidi	D809,176 S	1/2018	Partington
D698,985 S	2/2014	Lopez et al.	9,863,619 B2	1/2018	Mak
D699,384 S	2/2014	Rashidi	9,964,266 B2	5/2018	Danesh
D700,387 S	2/2014	Snell	D820,494 S	6/2018	Cohen
8,641,243 B1	2/2014	Rashidi	9,995,441 B2	6/2018	Power et al.
8,659,034 B2	2/2014	Baretz et al.	D829,663 S *	10/2018	Liu D13/137.2
D701,466 S	3/2014	Clifford et al.	D830,307 S *	10/2018	Liu D13/137.2
8,672,518 B2	3/2014	Boomgaarden et al.	D833,977 S	11/2018	Danesh et al.
D702,639 S *	4/2014	Ruffner D13/110	10,139,059 B2	11/2018	Danesh
D702,867 S	4/2014	Kim et al.	2002/0172047 A1	11/2002	Ashley
D703,843 S	4/2014	Cheng	2004/0001337 A1	1/2004	Defouw et al.
8,684,569 B2	4/2014	Pickard et al.	2005/0225966 A1	10/2005	Hartmann et al.
D705,472 S	5/2014	Huh	2005/0227536 A1	10/2005	Gamache et al.
8,727,582 B2	5/2014	Brown et al.	2005/0237746 A1	10/2005	Yiu
8,734,168 B2 *	5/2014	Lee H01R 31/06 439/171	2006/0158873 A1	7/2006	Newbold et al.
D710,529 S	8/2014	Lopez et al.	2006/0215408 A1	9/2006	Lee
8,801,217 B2	8/2014	Oehle et al.	2007/0035951 A1	2/2007	Tseng
D714,989 S	10/2014	Rowlette, Jr. et al.	2007/0185675 A1	8/2007	Papamichael et al.
8,870,426 B2	10/2014	Biebl et al.	2007/0206374 A1	9/2007	Petrakis et al.
8,890,414 B2	11/2014	Rowlette, Jr. et al.	2008/0112168 A1	5/2008	Pickard et al.
D720,695 S *	1/2015	Shen D13/110	2008/0112170 A1	5/2008	Trott
D721,845 S	1/2015	Lui et al.	2008/0112171 A1	5/2008	Patti et al.
D722,296 S	2/2015	Taylor	2008/0137347 A1	6/2008	Trott et al.
D722,978 S	2/2015	Hagarty	2008/0165545 A1	7/2008	O'Brien
8,950,898 B2	2/2015	Catalano	2008/0232116 A1	9/2008	Kim
D726,363 S	4/2015	Danesh	2009/0003009 A1	1/2009	Tessnow et al.
9,039,254 B2	5/2015	Danesh	2009/0034261 A1	2/2009	Grove
D731,689 S	6/2015	Bernard et al.	2009/0080189 A1	3/2009	Wegner
9,062,866 B1	6/2015	Christ et al.	2009/0086484 A1	4/2009	Johnson
9,065,264 B2	6/2015	Cooper et al.	2009/0135613 A1	5/2009	Peng
9,068,719 B2	6/2015	Van De Ven et al.	2009/0141500 A1	6/2009	Peng
D735,012 S	7/2015	Cowie	2009/0141506 A1	6/2009	Lan et al.
D735,142 S	7/2015	Hagarty	2009/0141508 A1	6/2009	Peng
9,078,299 B2	7/2015	Ashdown	2009/0147517 A1	6/2009	Li
D739,590 S	9/2015	Redfern	2009/0161356 A1	6/2009	Negley et al.
9,140,441 B2	9/2015	Goelz et al.	2009/0237924 A1	9/2009	Ladewig
D742,325 S	10/2015	Leung	2009/0280695 A1	11/2009	Sekela et al.
9,151,457 B2	10/2015	Pickard et al.	2009/0290343 A1	11/2009	Brown et al.
9,151,477 B2	10/2015	Pickard et al.	2010/0014282 A1	1/2010	Danesh
9,217,560 B2	12/2015	Harbers et al.	2010/0061108 A1	3/2010	Zhang et al.
9,222,661 B2	12/2015	Kim et al.	2010/0110690 A1	5/2010	Hsu et al.
9,285,103 B2	3/2016	Van De Ven et al.	2010/0110698 A1	5/2010	Harwood et al.
9,291,319 B2	3/2016	Kathawate et al.	2010/0148673 A1	6/2010	Stewart et al.
9,301,362 B2	3/2016	Dohn et al.	2010/0149822 A1	6/2010	Cogliano et al.
9,310,038 B2	4/2016	Athalye	2010/0244709 A1	9/2010	Steiner et al.
9,322,543 B2	4/2016	Hussell et al.	2010/0246172 A1	9/2010	Liu
9,347,655 B2	5/2016	Boomgaarden et al.	2010/0259919 A1	10/2010	Khazi et al.
9,371,966 B2	6/2016	Rowlette, Jr. et al.	2010/0270903 A1	10/2010	Jao et al.
D762,181 S	7/2016	Lin	2010/0302778 A1	12/2010	Dabiet et al.
9,395,051 B2	7/2016	Hussell et al.	2011/0043040 A1	2/2011	Porter et al.
D762,906 S	8/2016	Jeswani et al.	2011/0063831 A1	3/2011	Cook
D764,079 S	8/2016	Wu	2011/0068687 A1	3/2011	Takahasi et al.
9,417,506 B1	8/2016	Tirosh	2011/0069499 A1	3/2011	Trott et al.
D766,185 S	9/2016	Hagarty	2011/0080750 A1	4/2011	Jones et al.
D768,325 S	10/2016	Xu	2011/0116276 A1	5/2011	Okamura et al.
D768,326 S	10/2016	Guzzini	2011/0134634 A1	6/2011	Gingrich, III et al.
D769,501 S	10/2016	Jeswani et al.	2011/0134651 A1	6/2011	Berman
D770,065 S	10/2016	Tittle	2011/0170294 A1	7/2011	Mier-Langner et al.
9,476,552 B2	10/2016	Myers et al.	2011/0194299 A1	8/2011	Crooks et al.
D776,324 S	1/2017	Gierl et al.	2011/0216534 A1	9/2011	Tickner et al.
9,534,751 B2	1/2017	Maglica et al.	2011/0226919 A1	9/2011	Fryzek et al.
D778,241 S	2/2017	Holbrook et al.	2011/0255292 A1	10/2011	Shen
D778,484 S	2/2017	Guzzini	2011/0267828 A1	11/2011	Bazydola et al.
9,581,302 B2	2/2017	Danesh	2011/0285314 A1	11/2011	Carney et al.
			2012/0020104 A1	1/2012	Biebl et al.

2012/0074852	A1	3/2012	Delnoij	EP	2 453 169	A2	5/2012
2012/0106176	A1	5/2012	Lopez et al.	EP	2 193 309	B1	7/2012
2012/0113642	A1	5/2012	Catalano	GB	2509772	A	7/2014
2012/0140442	A1	6/2012	Woo et al.	JP	2007265961	A	10/2007
2012/0162994	A1	6/2012	Wasniewski et al.	JP	2011060450	A2	3/2011
2012/0182744	A1	7/2012	Santiago et al.	JP	2012064551	A2	3/2012
2012/0188762	A1	7/2012	Joung et al.	JP	2015002027	A2	1/2015
2012/0243237	A1	9/2012	Toda et al.	JP	2015002028	A2	1/2015
2012/0287625	A1	11/2012	Macwan et al.	JP	2017107699	A2	6/2017
2013/0009552	A1	1/2013	Page	KR	1020110008796	A	1/2011
2013/0010476	A1	1/2013	Pickard et al.	KR	1020120061625	A	6/2012
2013/0033872	A1	2/2013	Randolph et al.	WO	WO 2013/128896	A1	9/2013
2013/0051012	A1	2/2013	Oehle et al.	WO	WO 2015/000212	A1	1/2015
2013/0141913	A1	6/2013	Sachsenweger	WO	WO 2016152166	A2	9/2016
2013/0163254	A1	6/2013	Chang et al.				
2013/0170233	A1	7/2013	Nezu et al.				
2013/0258677	A1	10/2013	Fryzek et al.				
2013/0265750	A1	10/2013	Pickard et al.				
2013/0271989	A1	10/2013	Hussell et al.				
2013/0294084	A1	11/2013	Kathawate et al.				
2013/0301252	A1	11/2013	Hussell et al.				
2013/0322062	A1	12/2013	Danesh				
2013/0335980	A1	12/2013	Nakasuji et al.				
2014/0036497	A1	2/2014	Hussell et al.				
2014/0049957	A1	2/2014	Goelz et al.				
2014/0063776	A1	3/2014	Clark et al.				
2014/0071679	A1	3/2014	Booth				
2014/0071687	A1	3/2014	Tickner et al.				
2014/0140490	A1	5/2014	Roberts et al.				
2014/0063818	A1	6/2014	Randolph et al.				
2014/0254177	A1	9/2014	Danesh				
2014/0321122	A1	10/2014	Domagala et al.				
2014/0347848	A1	11/2014	Pisavadia et al.				
2015/0009676	A1	1/2015	Danesh				
2015/0138779	A1	5/2015	Livesay et al.				
2015/0184837	A1	7/2015	Zhang et al.				
2015/0198324	A1	7/2015	O'Brien et al.				
2015/0233556	A1	8/2015	Danesh				
2015/0263497	A1	9/2015	Korcz et al.				
2015/0276185	A1	10/2015	Bailey et al.				
2015/0362159	A1	12/2015	Ludyjan				
2016/0312987	A1	10/2016	Danesh				
2016/0348860	A1	12/2016	Danesh				
2016/0348861	A1	12/2016	Bailey et al.				
2016/0366738	A1	12/2016	Boulanger et al.				
2017/0045213	A1	2/2017	Williams et al.				
2017/0059135	A1	3/2017	Jones				
2017/0138576	A1	5/2017	Peng et al.				
2017/0138581	A1	5/2017	Doust				
2017/0307188	A1	10/2017	Oudina et al.				

OTHER PUBLICATIONS

2006 International Building Code, Section 712 Penetrations, 2006, 4 pages.

Acrich COB Zhaga Module, Product Description, Seoul Semiconductor, Nov. 2016, 39 pages.

<<https://www.zhagastandard.org/books/book18/>>, Mar. 2017, 5 pages.

BXUV.GuideInfo, Fire Resistance Ratings—ANSI/UL 263, UL Online Certifications Directory, last updated Nov. 3, 2016, 27 pages.

CEYY.GuideInfo, Outlet Boxes and Fittings Certified for Fire Resistance, UL Online Certifications Directory, last updated May 16, 2013, 2 pages.

Canadian Office Action dated Dec. 23, 2013 from Canadian Application No. 2,778,581, 3 pages.

Canadian Office Action dated Mar. 22, 2016 from Canadian Application No. 2,879,629, 4 pages.

Canadian Office Action dated Mar. 9, 2017 from Canadian Application No. 2,931,588, 5 pages.

Canadian Office Action dated Feb. 1, 2016 from Canadian Application No. 2,879,486, 5 pages.

Canadian Office Action dated Jun. 12, 2017 from Canadian Application No. 2,927,601, 4 pages.

Canadian Office Action dated Aug. 11, 2017 from Canadian Application No. 2,941,051, 4 pages.

Carlton® Zip Box® Blue™ Switch and Outlet Boxes, Product Brochure, <http://www.carlonsales.com/brochures.php>, 2006, 22 pages.

Cree LED Lamp Family Sales Sheet—Better light is beautiful light, Apr. 24, 2017, 2 pages.

DME Series Installation Instructions, Oct. 18, 2011, 2 pages.

DMF, Inc., “dmfLIGHTING: LED Recessed Lighting Solutions,” Info sheets, Mar. 15, 2012, 4 pages.

DMF, Inc., “dmfLIGHTING: LED Recessed Downlighting,” DRD2 Product Brochure, Oct. 23, 2014, 50 pages.

DMF, Inc., “dmfLIGHTING: LED Recessed Downlighting,” Product Catalog, Aug. 2012, 68 pages.

Final Office Action dated Apr. 27, 2016 from U.S. Appl. No. 14/184,601, 19 pages.

Final Office Action dated Jul. 26, 2017 from U.S. Appl. No. 14/184,601, 18 pages.

Final Office Action dated Jan. 29, 2016 from U.S. Appl. No. 14/183,424, 21 pages.

Final Office Action dated Jun. 23, 2016 from U.S. Appl. No. 13/484,901, 18 pages.

Final Office Action dated Apr. 2, 2015 from U.S. Appl. No. 13/484,901, 13 pages.

Halo, Halo LED H4 H7 Collection, SustainableLEDesign, Cooper Lighting, (emphasis on p. 18 “H7 Collection LED Modules—Halo LED H7 Module Features,”) Mar. 28, 2012, 52 pages.

Halo, H7 LED Downlight Trims 49x Series, 6-inch LED Trims for Use with MI7x LED Modules, Cooper Lighting, ADV110422, rev. Aug. 12, 2011, 15 pages.

Halo, LED Module ML706x, Cooper Lighting, General Installation for All Modules/p. 1; Tether Installation/pp. 2-3; Installation into HALO H750x Series LED—only (Non-Screw Based), Recessed Fixture, p. 4, Oct. 20, 2009, 4 pages.

“Membrane Penetrations in Fire-Resistance Rated Walls,” https://www.ul.com/wp-content/uploads/2014/04/ul_MembranePenetrations.pdf, Issue 1, 2009, 2 pages.

FOREIGN PATENT DOCUMENTS

CA	2815067	11/2013
CN	201259125 Y	6/2009
CN	101608781 A	12/2009
CN	201636626 U	11/2010
CN	202392473 U	8/2012
CN	202733693 U	2/2013
CN	103307518 A	9/2013
CN	103322476 A	9/2013
CN	203215483 U	9/2013
CN	101498411 B	11/2013
CN	203273663 U	11/2013
CN	203297980 U	11/2013
CN	203628464 U	12/2013
CN	203641919 U	6/2014
CN	104654142 A	5/2015
CN	204513161 U	7/2015
CN	204611541 U	9/2015
CN	204829578 U	12/2015
CN	103712135 B	4/2016
CN	205606362 U	9/2016
CN	206130742 U	4/2017
CN	103154606 B	5/2017
DE	9109828 U1	2/1992
EP	1 672 155 A1	6/2006
EP	2 095 938 A1	2/2008
EP	2 306 072 A1	4/2011

“Metallic Outlet Boxes,” UL 514A, Underwriters Laboratories, Inc., Feb. 16, 2004 (Title Page Reprinted Aug. 10, 2007), 106 pages.

“Metallic and Non-metallic Outlet Boxes Used in Fire-rated Assembly,” <https://iaeimagazine.org/magazine/2000/09/16/metallic-and-non-metallic-outlet-boxes-used-in-fire-rated-assembly/>, Sep. 16, 2000, 5 pages.

Notice of Allowance dated Mar. 26, 2018 for U.S. Appl. No. 14/184,601, 10 pages.

Non-Final Office Action dated Mar. 15, 2010 from U.S. Appl. No. 12/100,148, 8 pages.

Non-Final Office Action dated Apr. 30, 2010 from U.S. Appl. No. 12/173,232, 13 pages.

Non-Final Office Action dated Sep. 5, 2014 from U.S. Appl. No. 13/791,087, 8 pages.

Non-Final Office Action dated Jul. 20, 2015 from U.S. Appl. No. 14/184,601, 16 pages.

Non-Final Office Action dated Dec. 15, 2016 from U.S. Appl. No. 14/184,601, 18 pages.

Non-Final Office Action dated Feb. 6, 2018 from U.S. Appl. No. 15/167,682, 9 pages.

Non-Final Office Action dated Sep. 15, 2015 from U.S. Appl. No. 13/484,901, 16 pages.

Non-Final Office Action dated Oct. 16, 2014 from U.S. Appl. No. 13/484,901, 11 pages.

Non-Final Office Action dated Sep. 6, 2017 from U.S. Appl. No. 14/726,064, 8 pages.

Non-Final Office Action dated May 17, 2017 from U.S. Appl. No. 14/183,424, 20 pages.

Non-Final Office Action dated Jun. 2, 2015 from U.S. Appl. No. 14/183,424, 20 pages.

Non-Final Office Action dated Apr. 12, 2018 for U.S. Appl. No. 29/638,259, 5 pages.

Non-Final Office Action dated May 16, 2018 for U.S. Appl. No. 15/132,875, 18 pages.

Notice of Allowance dated Jan. 30, 2015 from U.S. Appl. No. 13/791,087, 9 pages.

Notice of Allowance dated Jan. 16, 2015 from U.S. Appl. No. 29/467,026, 9 pages.

Notice of Allowance dated Oct. 21, 2016 from U.S. Appl. No. 13/484,901, 7 pages.

Notice of Allowance dated Mar. 24, 2016 from U.S. Appl. No. 14/247,149, 8 pages.

Notice of Allowance dated May 22, 2018 from U.S. Appl. No. 14/183,424, 9 pages.

Notice of Allowance dated May 10, 2018 from U.S. Appl. No. 14/726,064, 7 pages.

Notice of Allowance dated Aug. 23, 2017 from Canadian Application No. 2,879,629, 1 page.

“Outlet Boxes for Use in Fire Rated Assemblies,” https://www.ul.com/wp-content/uploads/2014/04/UI_outletboxes.pdf, 2011, 2 pages.

Notice of Allowance dated Sep. 21, 2018 from U.S. Appl. No. 29/645,941, 5 pages.

“Advanced LED Solutions,” Imtra Marine Lighting. 2011. 39 pages.

“Cree LMH2 LED Module with TrueWhite Technology,” Cree Product Family Data Sheet. 2011. 3 pages.

“Cree LMH2 LED Modules Design Guide,” Cree Product Design Guide. 2011. 20 pages.

“Cree LMH2 LED Modules,” Mouser Electronics. 2 pages.

“LED Undercabinet Pocket Guide,” ELCO Lighting. 12 pages.

“Portland Bi-Color, Warm White/Red,” item:ILIM30941.Imtra Marine Products. 2012. 3 pages.

“Undercabinet Pucks, Xyris Mini LED Puck Light,” ELCO Lighting. Sep. 2018. 1 page.

“VERSI LED Mini Flush,” Lithonia Lighting. 6 pages.

Canadian Office Action dated Dec. 6, 2016 from Canadian Application No. 2,879,629, 3 pages.

Non-Final Office Action dated Jun. 25, 2018 for U.S. Appl. No. 29/541,565, 10 pages.

Non-Final Office Action dated Oct. 24, 2018 for U.S. Appl. No. 15/688,266, 14 pages.

Notice of Allowance dated Oct. 4, 2018 from U.S. Appl. No. 15/947,065, 9 pages.

Notice of Allowance dated Oct. 9, 2018 from U.S. Appl. No. 29/653,142, 7 pages.

Notice of Allowance dated Sep. 19, 2018 from U.S. Appl. No. 15/167,682, 7 pages.

OneFrame Recessed LED Downlight. Dmflighting.com. Published Jun. 6, 2018. Retrieved at <https://www.dmflighting.com/product/oneframe> on Jun. 6, 2018. 11 pages.

International Search Report and Written Opinion in PCT/US2018/048357 dated Nov. 14, 2018, 13 pages.

Notice of Allowance dated Nov. 27, 2018 from U.S. Appl. No. 15/167,682, 11 pages.

Non-Final Office Action dated Dec. 5, 2018 from U.S. Appl. No. 14/942,937, 13 pages.

International Search Report and Written Opinion in International Patent Application No. PCT/US18/39048 dated Dec. 14, 2018. 24 pages.

Notice of Allowance dated Jan. 2, 2019 from U.S. Appl. No. 29/541,565, 6 pages.

Civil Action No. 2:18-cv-07090. Complaint for Infringement and Unfair Competition. *DMF, Inc. v. AMP Plus, Inc. d/b/a ELCO Lighting*. 52 pages. Dated Aug. 15, 2018.

RACO 4 in. Octagon Welded Concrete Ring, 3-1/2 in. Deep with 1/2 and 3/4 in. Knockouts and includes 890 cover (20-Pack). Model # 280. Accessed at <https://www.homedepot.com/p/RACO-4-in-Octagon-Welded-Concrete-Ring-3-1-2-in-Deep-with-1-2-and-3-4-in-Knockouts-and-includes-890-cover-20-Pack-280/203638679> on Jan. 18, 2019. 3 pages.

RACO 4 in. Octagon Welded Concrete Ring, 6 in. Deep with 1/2 and 3/4 in. Knockouts (10-Pack). Model # 276. Accessed at <https://www.homedepot.com/p/RACO-4-in-Octagon-Welded-Concrete-Ring-6-in-Deep-with-1-2-and-3-4-in-Knockouts-10-Pack-276/203638675> on Jan. 16, 2019. 4 pages.

* cited by examiner

Primary Examiner — Rosemary K Tarcza

Assistant Examiner — Christy M Nemeth

(74) *Attorney, Agent, or Firm* — Smith Baluch LLP

(57)

CLAIM

The ornamental design for an electrical junction box, as shown and described.

DESCRIPTION

FIG. 1 is a top, side perspective view of an electrical junction box of our new design, according to a first embodiment;

FIG. 2 is another top, side perspective view thereof;

FIG. 3 is a top plan view thereof;

FIG. 4 is a front elevation view thereof, the rear elevation view being identical;

FIG. 5 is a right-side elevation view thereof, the left-side elevation view being identical;

FIG. 6 is a bottom plan view thereof;

FIG. 7 is a front, right-side, bottom perspective view thereof;

FIG. 8 is a top plan view thereof;

FIG. 9 is a front elevation view thereof, the rear elevation view being identical;

FIG. 10 is a right-side view thereof, the left-side view being identical;

FIG. 11 is a bottom plan view thereof;

FIG. 12 is a front, right-side, bottom perspective view thereof;

FIG. 13 is a top, side perspective view of an electrical junction box of our new design, according to a second embodiment;

FIG. 14 is a top plan view thereof;

FIG. **15** is a front elevation view thereof, the rear elevation view being identical;

FIG. **16** is a right-side elevation view thereof, the left-side elevation view being identical;

FIG. **17** is a bottom plan view thereof; and,

FIG. **18** is a front, right-side, bottom perspective view thereof.

The dash-dash broken lines in the drawings are for the purpose of illustrating environmental subject matter and portions of the electrical junction box that form no part of the claimed design. The dash-dot broken lines are for the purpose of illustrating a boundary and forms no part of the claimed design.

1 Claim, 11 Drawing Sheets

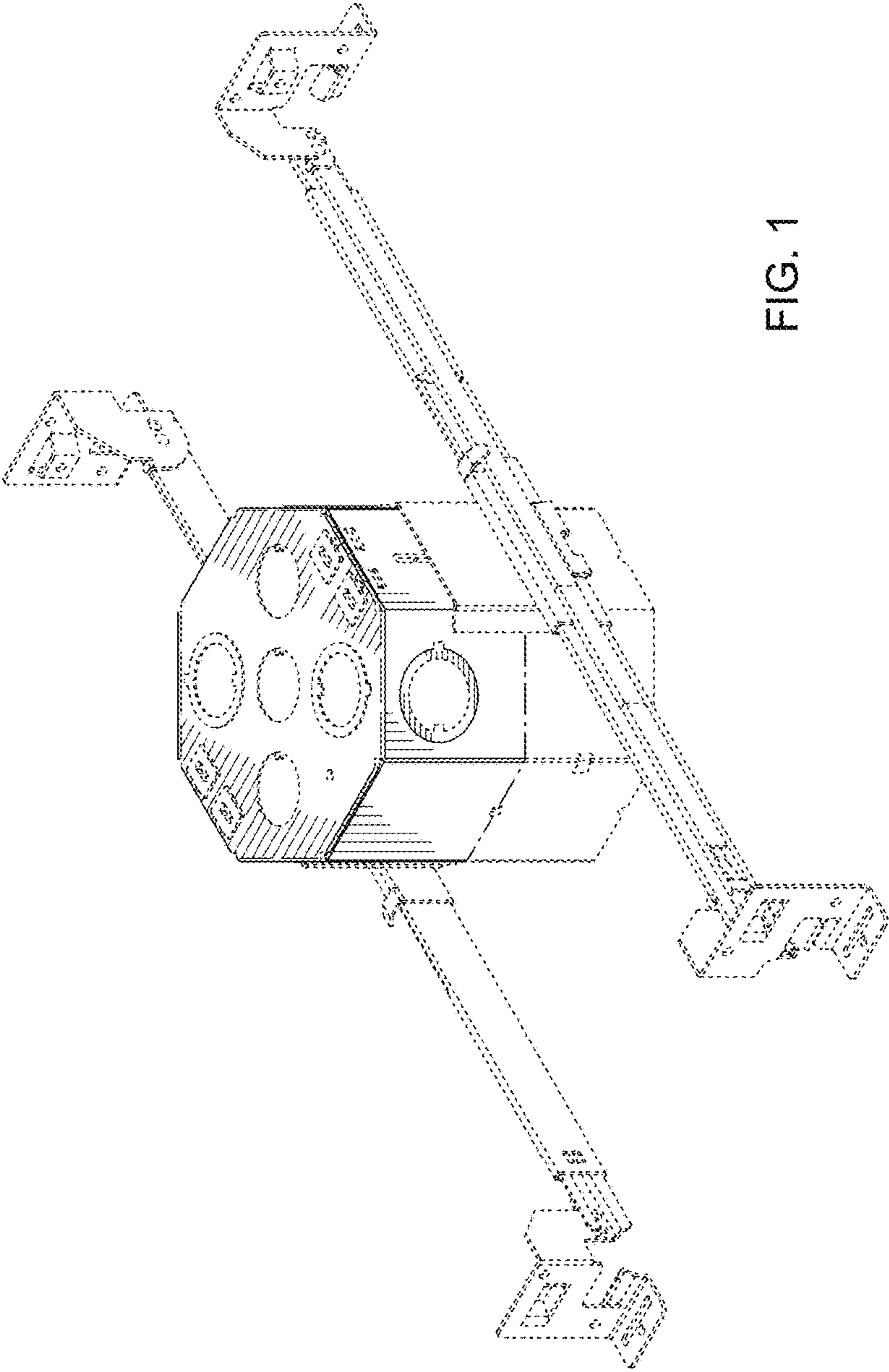

FIG. 1

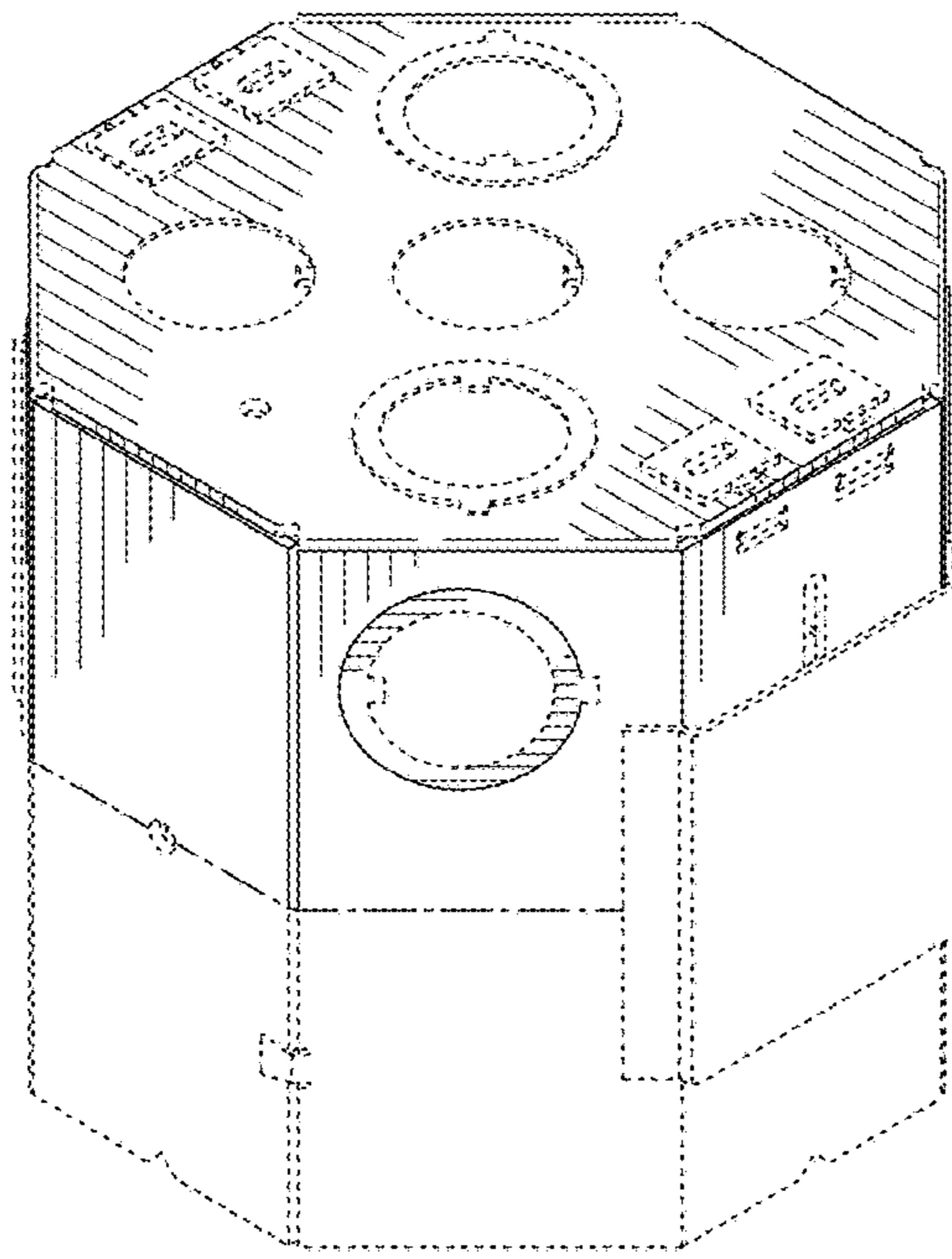

FIG. 2

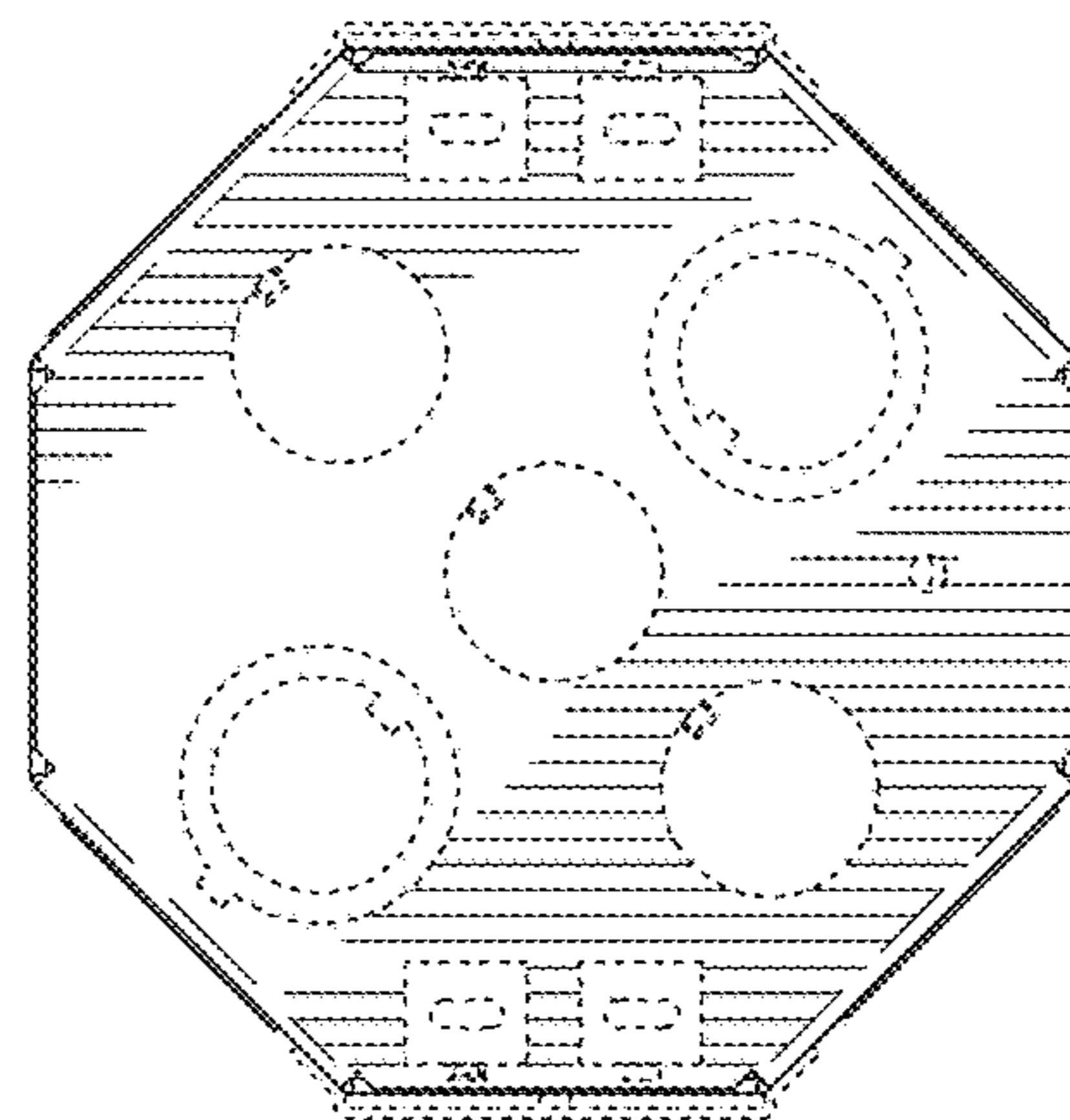

FIG. 3

FIG. 4

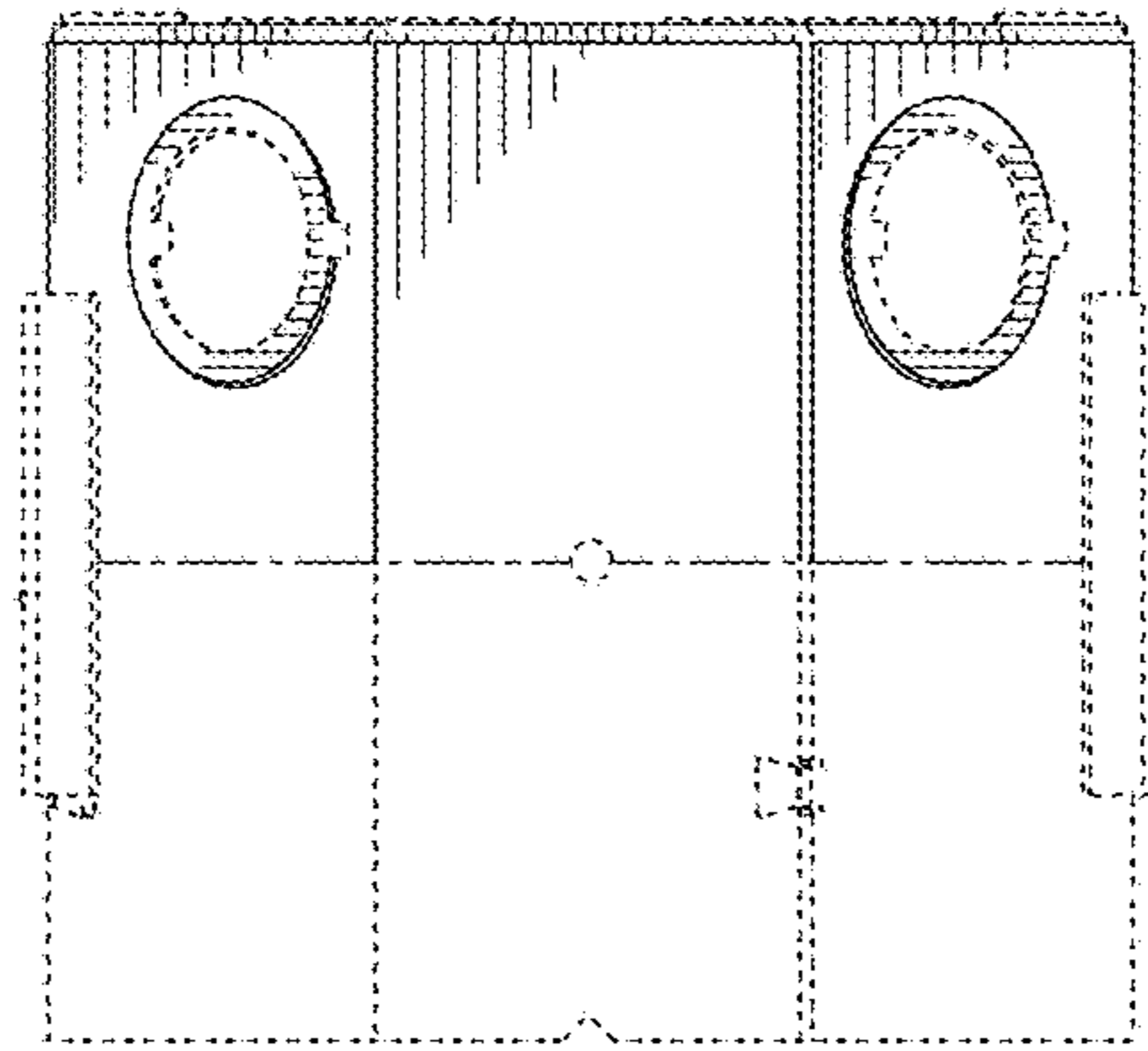

FIG. 5

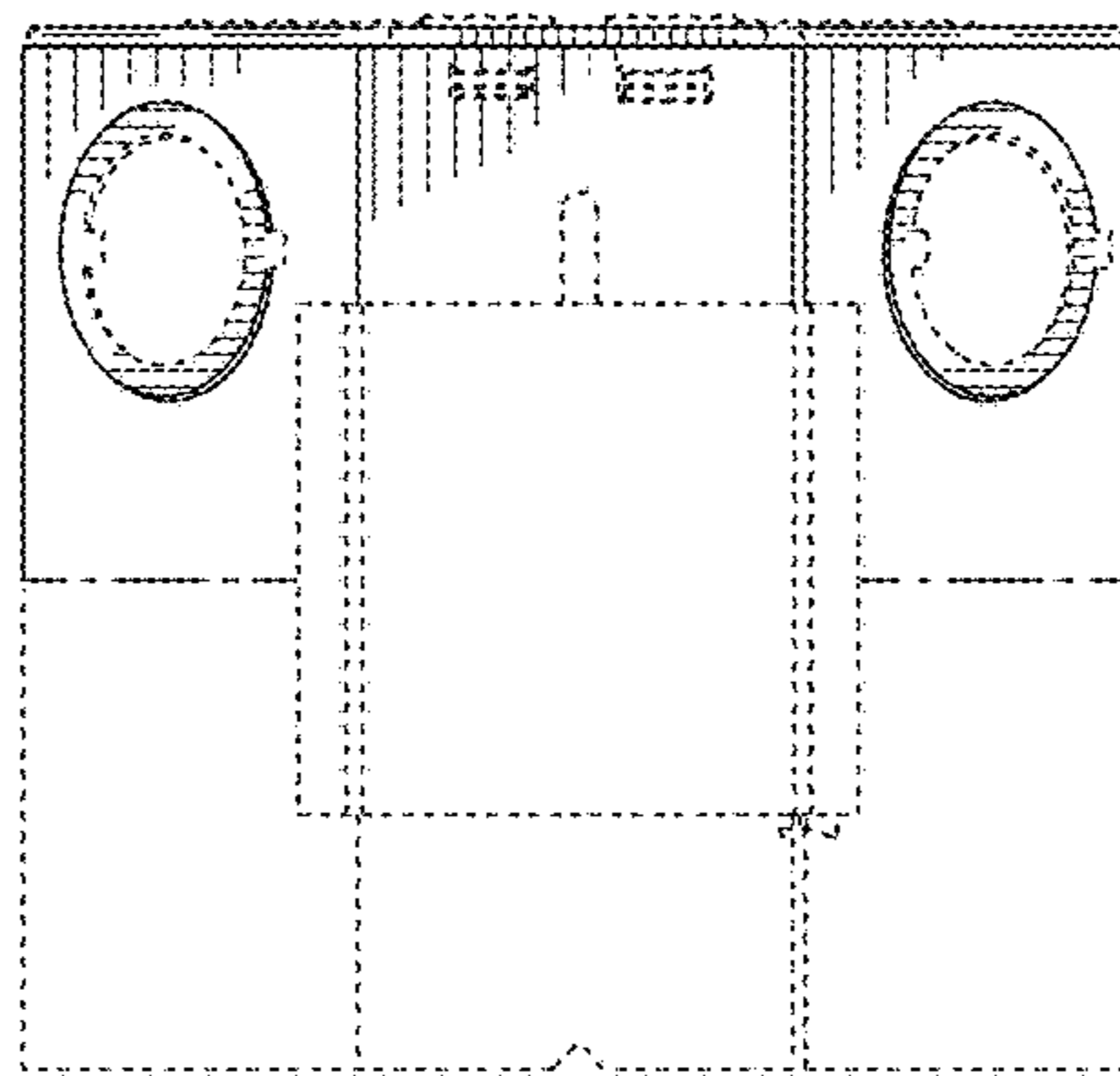

FIG. 6

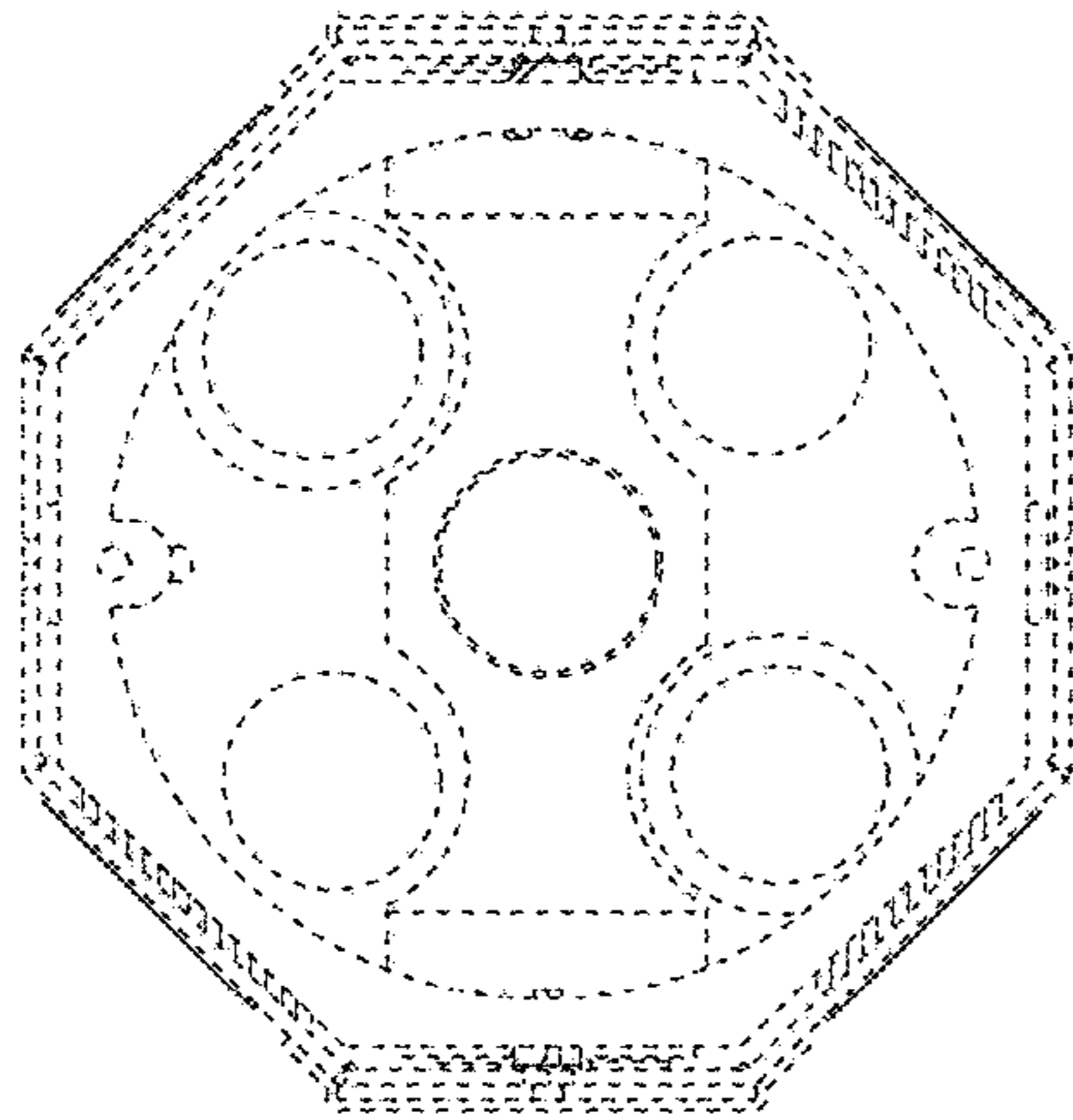
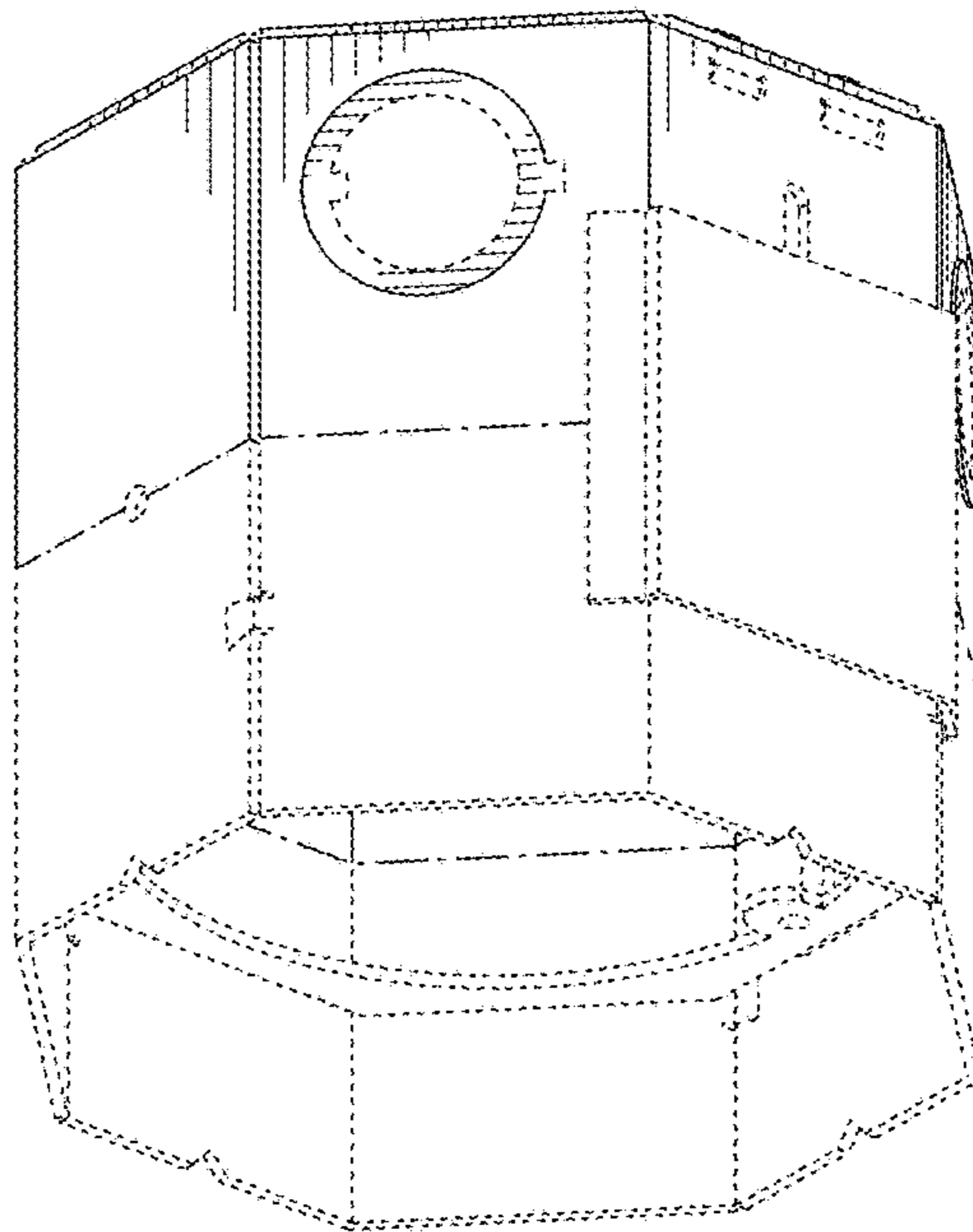

FIG. 7



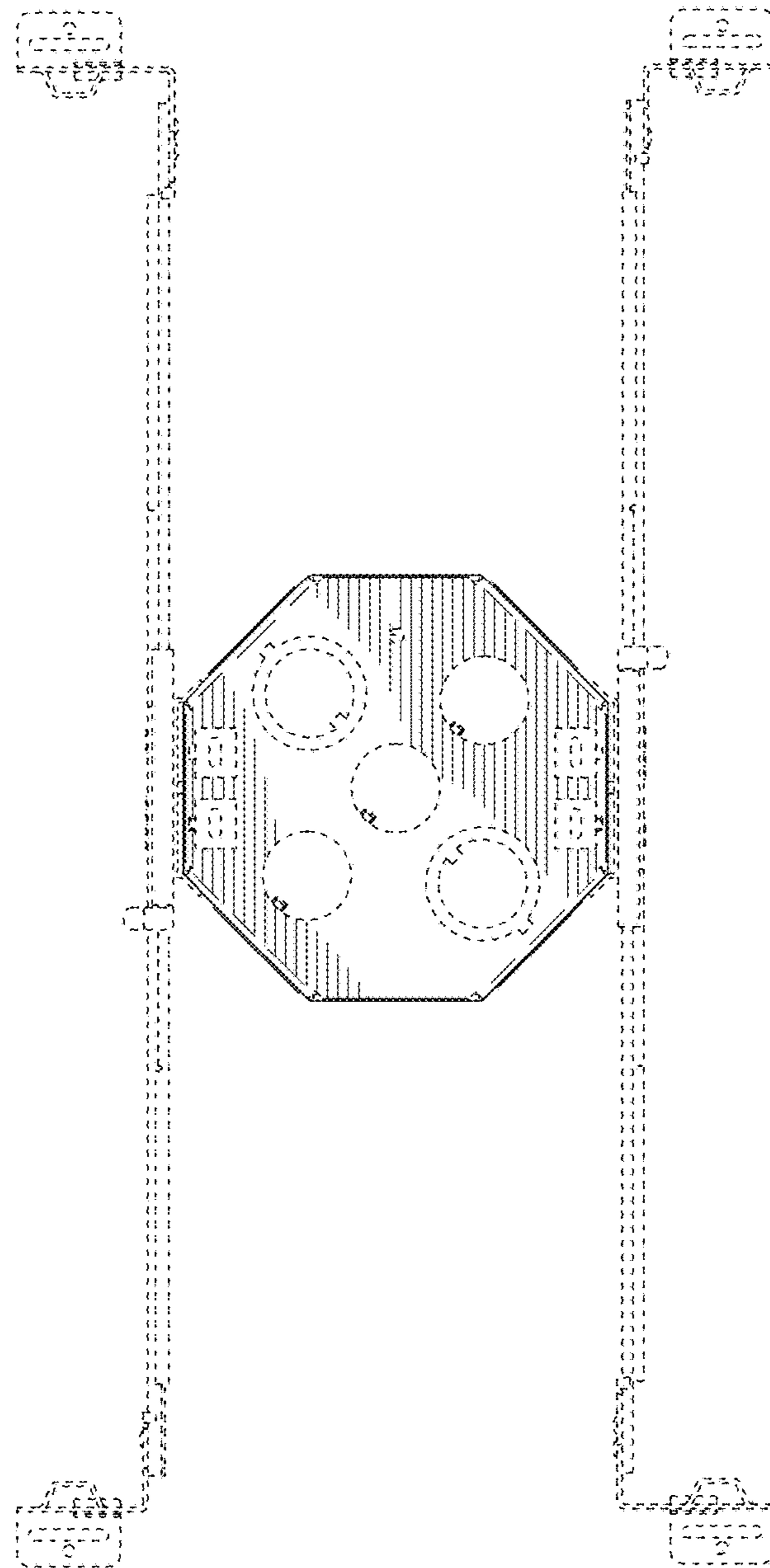

FIG. 8

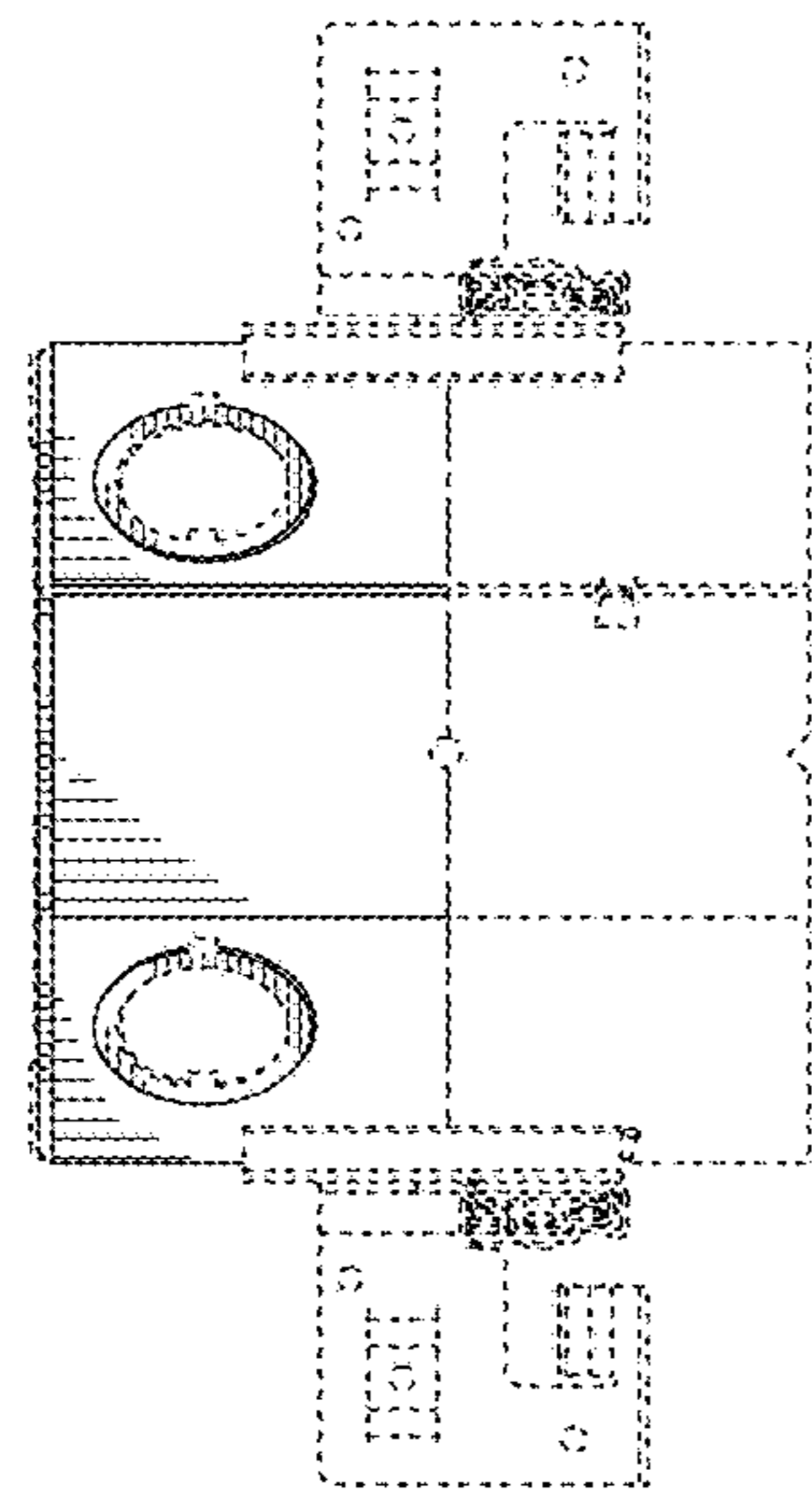

FIG. 9

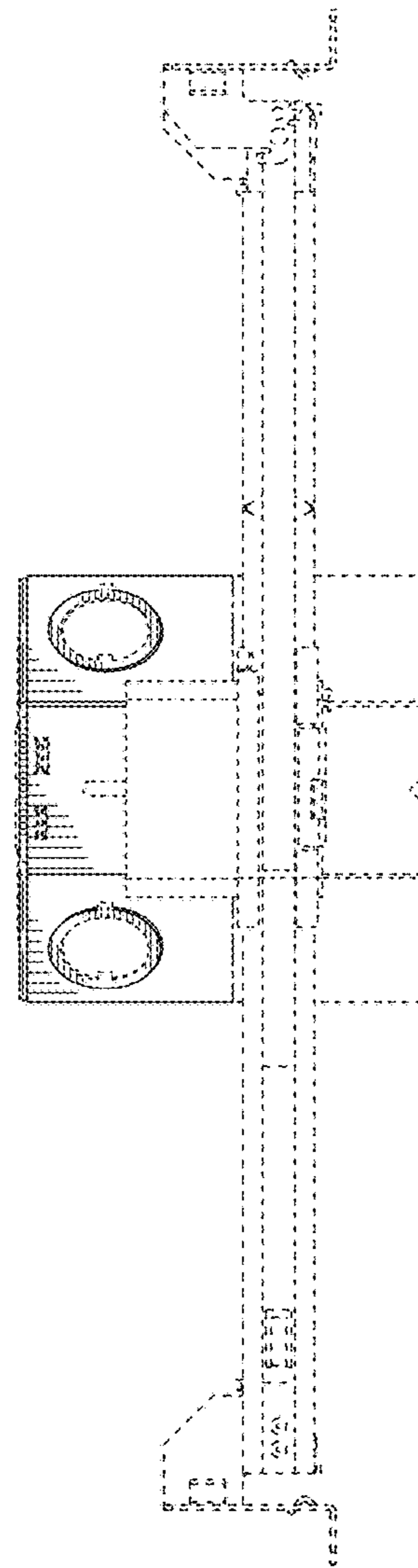

FIG. 10

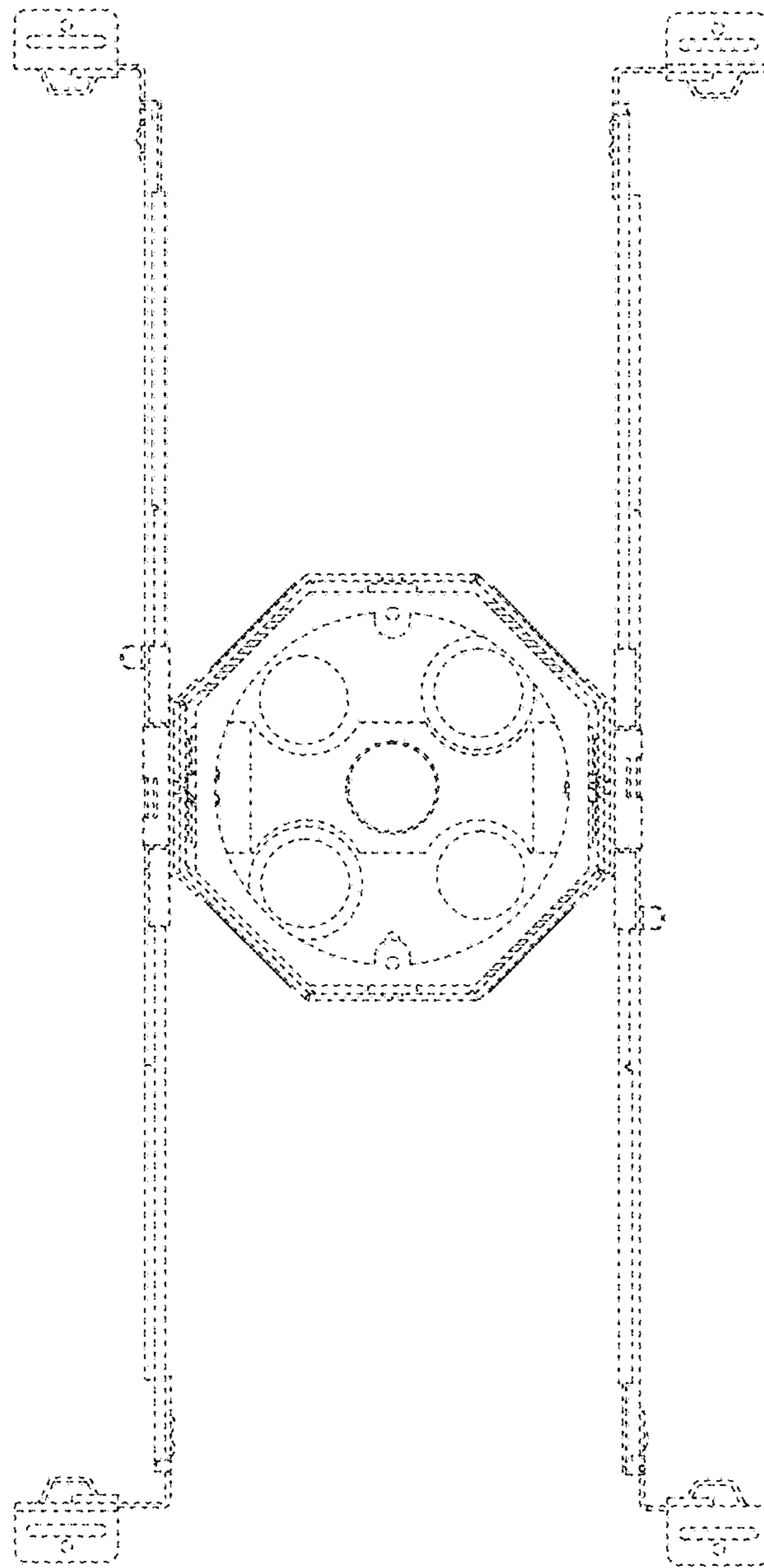

FIG. 11

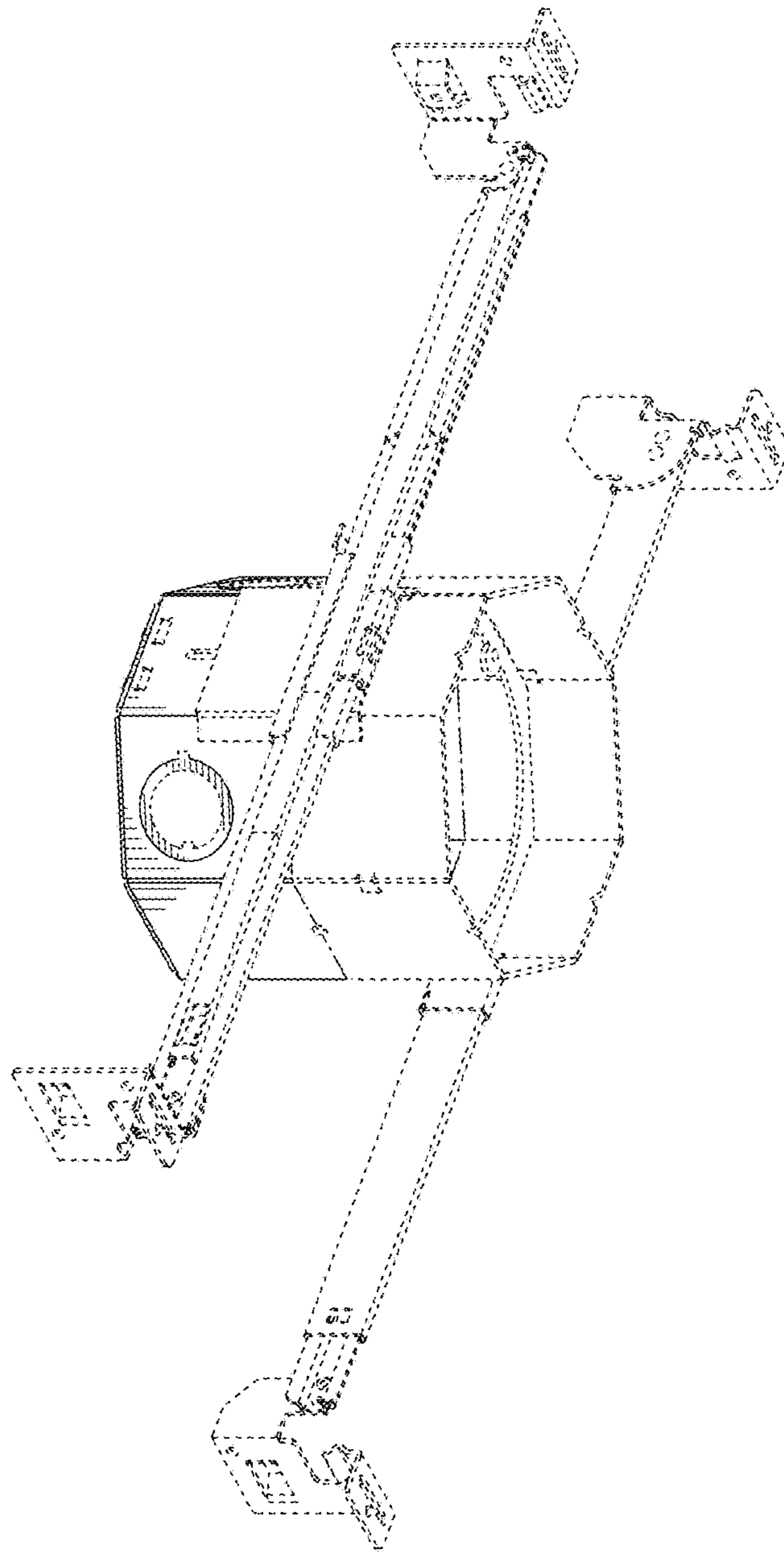

FIG. 12

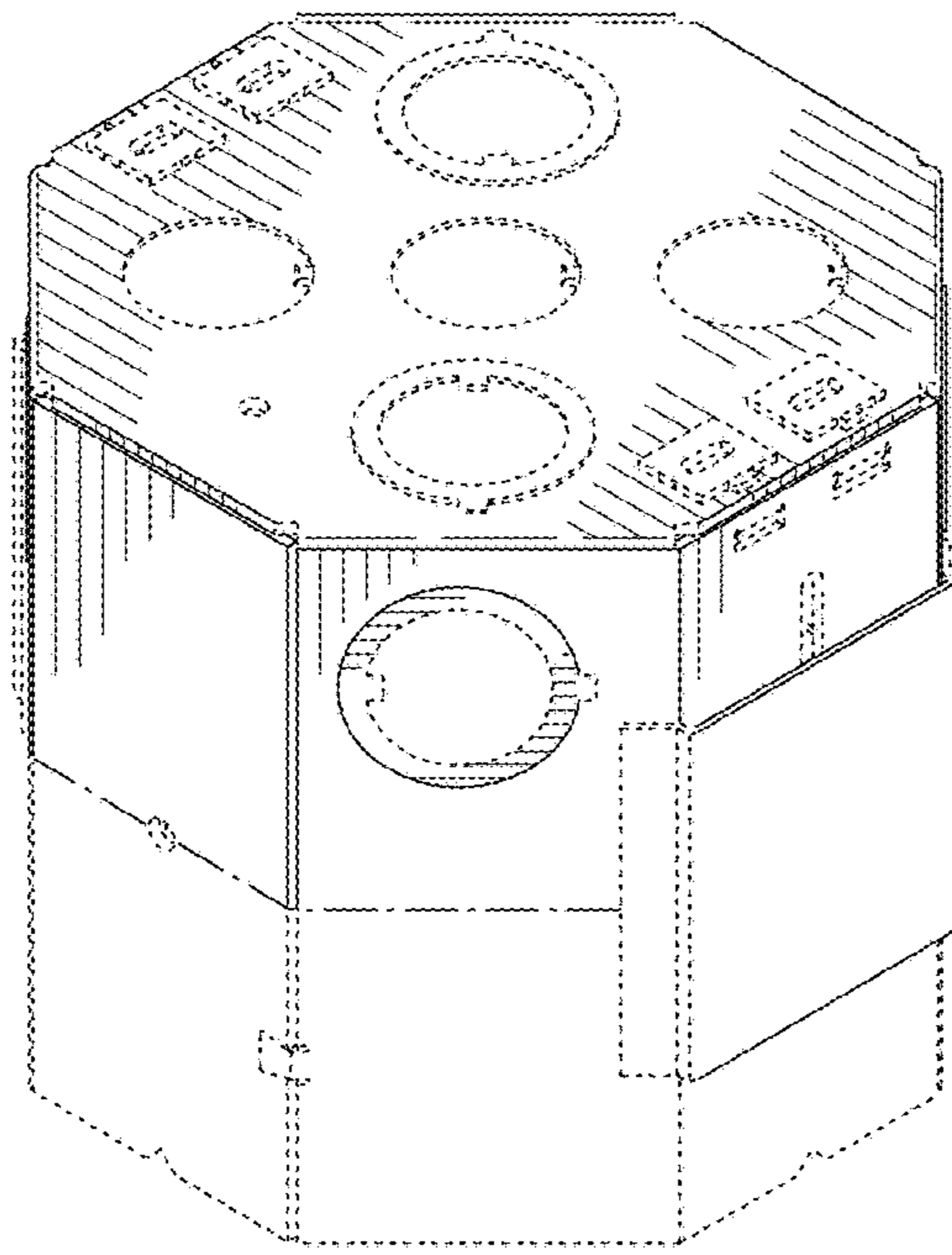

FIG. 13

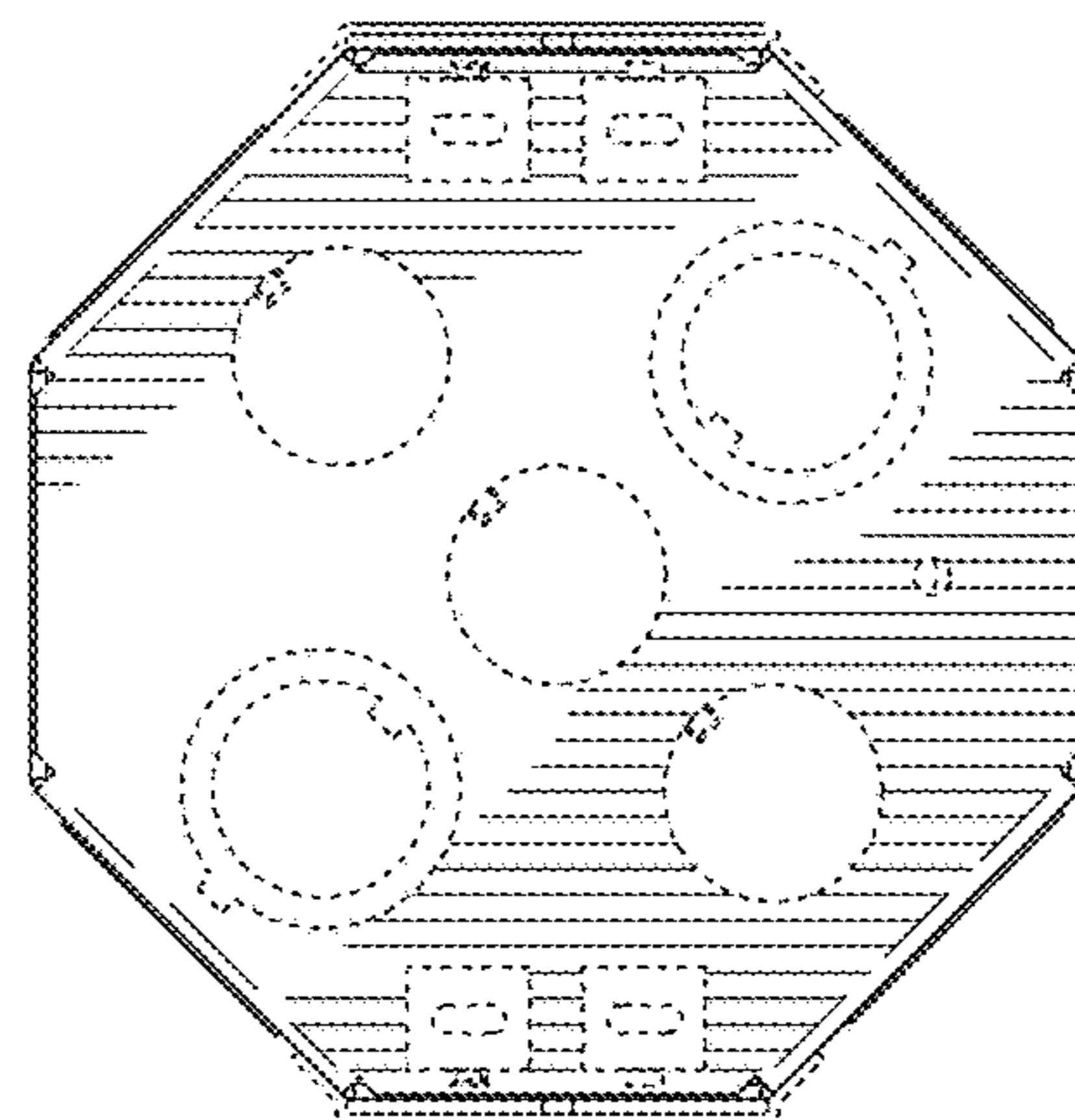

FIG. 14

FIG. 15

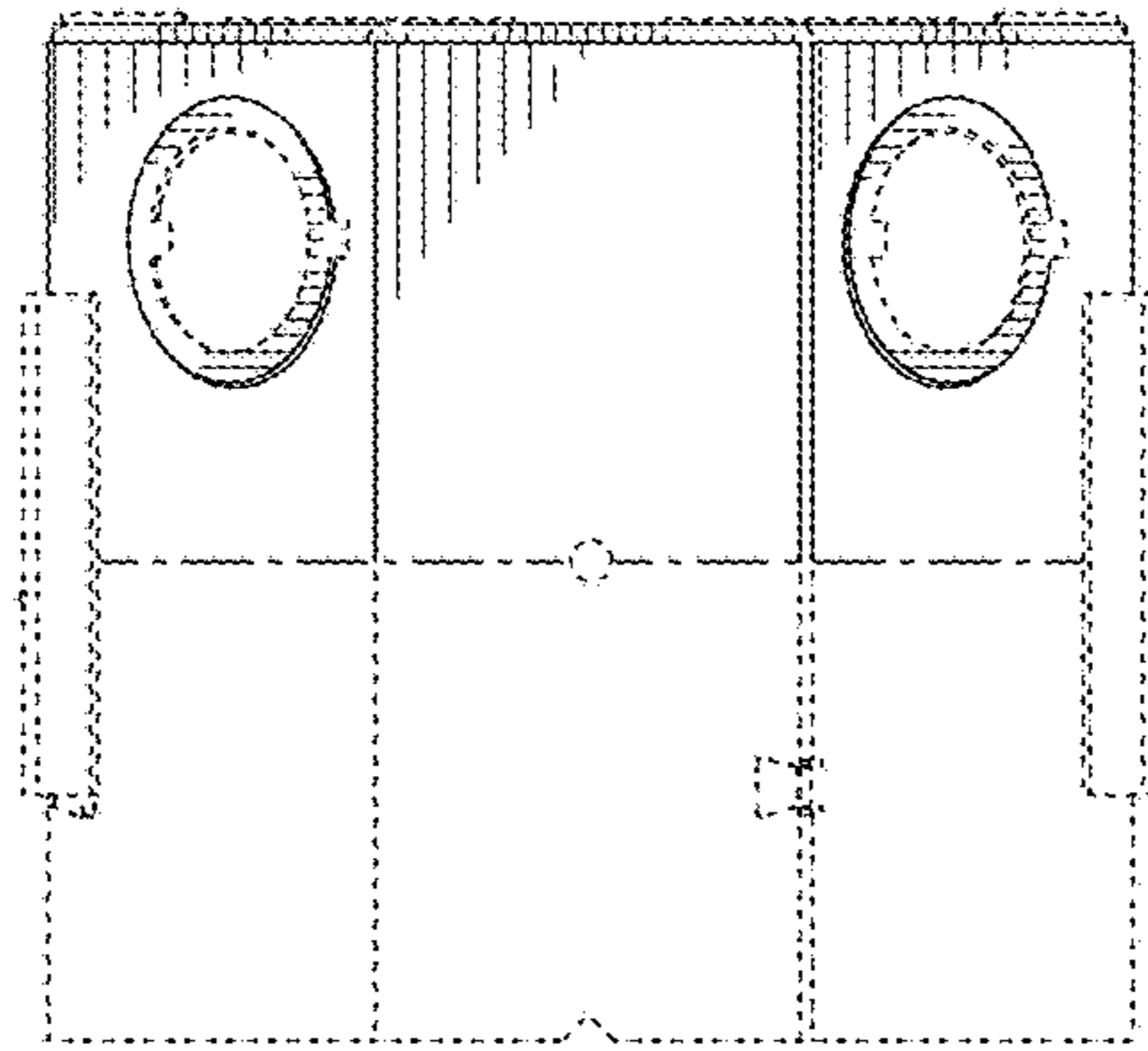

FIG. 16

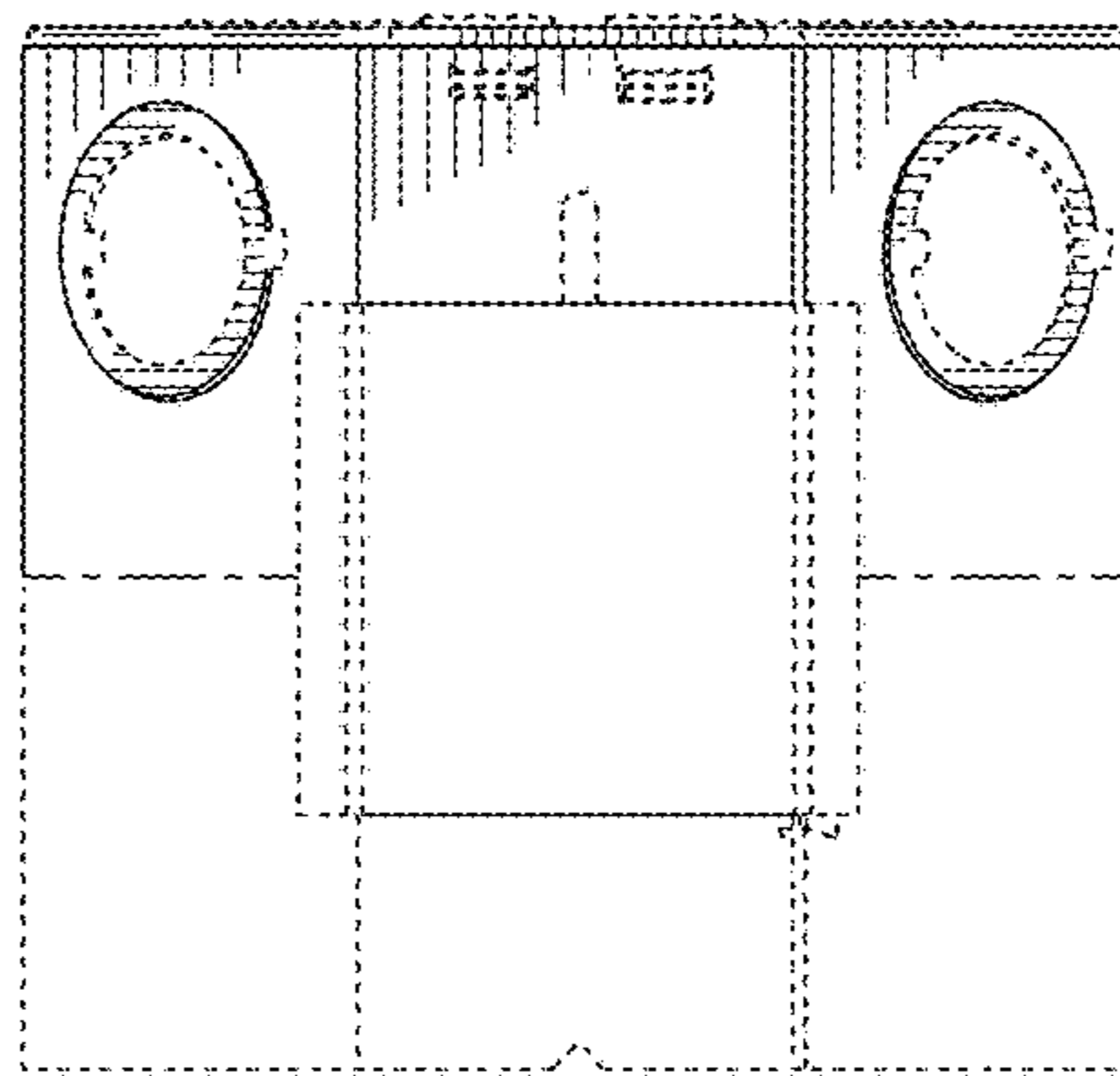

FIG. 17

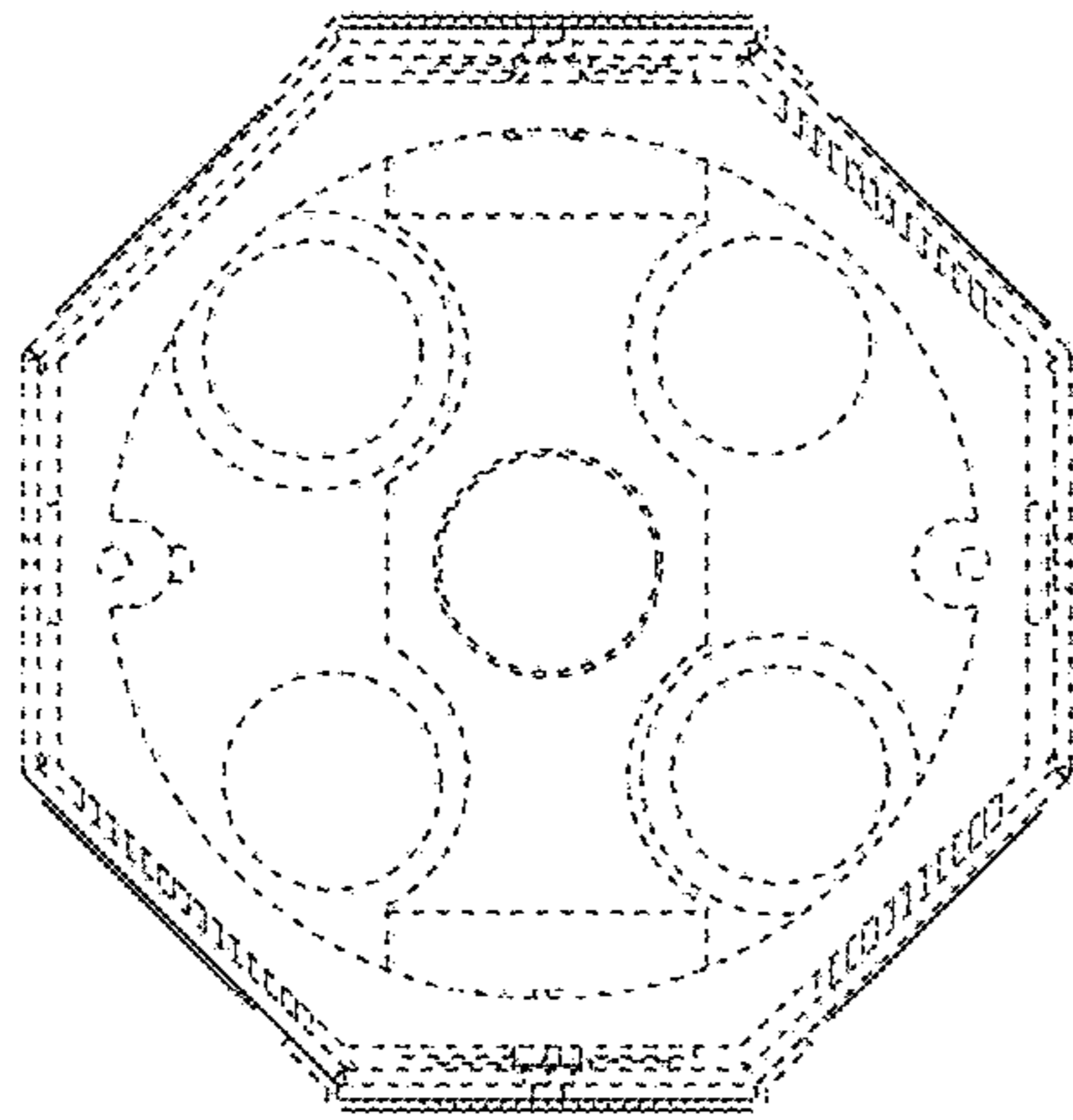

FIG. 18

