



US00D847933S

(12) **United States Design Patent**
Windfeldt

(10) **Patent No.:** **US D847,933 S**

(45) **Date of Patent:** **** May 7, 2019**

- (54) **STOCK FOR A GUN**
- (71) Applicant: **Maxim Defense Industries, LLC**, St. Cloud, MN (US)
- (72) Inventor: **Michael G. Windfeldt**, St. Augusta, MN (US)
- (73) Assignee: **Maxim Defense Industries, LLC**, St. Cloud, MN (US)
- (**) Term: **15 Years**
- (21) Appl. No.: **29/607,161**
- (22) Filed: **Jun. 9, 2017**
- (51) **LOC (11) Cl.** **22-01**
- (52) **U.S. Cl.**
USPC **D22/108**
- (58) **Field of Classification Search**
USPC D22/101, 107-111; D21/572-575
CPC F41C 23/00; F41C 23/04; F41C 23/10;
F41C 23/14; F41C 23/16; F41C 23/18;
F41C 27/00; F41C 27/06; F41A 5/18;
F41A 5/24; F41A 21/28
See application file for complete search history.

| | | |
|--------------|---------|--------------------|
| 2,400,422 A | 5/1946 | Johnson, Jr. |
| 2,424,194 A | 7/1947 | Sampson et al. |
| 2,433,151 A | 12/1947 | Parsons |
| 2,766,542 A | 10/1956 | Harvey |
| 3,044,204 A | 7/1962 | Zimmerman |
| 3,348,328 A | 10/1967 | Roy |
| 3,618,248 A | 11/1971 | Into et al. |
| 3,618,249 A | 11/1971 | Grandy |
| 4,115,943 A | 9/1978 | Musgrave |
| 4,141,166 A | 2/1979 | Schultz |
| 4,271,623 A | 6/1981 | Beretta |
| 4,327,626 A | 5/1982 | McQueen |
| 4,383,384 A | 5/1983 | Fox |
| 4,512,101 A | 4/1985 | Waterman, Jr. |
| 4,551,937 A | 12/1985 | Seehase |
| 4,697,367 A | 10/1987 | Brophy |
| 4,735,007 A | 4/1988 | Gal |
| 4,788,785 A | 12/1988 | White |
| D324,557 S | 3/1992 | Livingston |
| 5,209,215 A | 5/1993 | Morrison |
| 5,225,613 A | 7/1993 | Claridge |
| 5,622,000 A | 4/1997 | Marlowe |
| 5,711,102 A | 1/1998 | Plaster et al. |
| D391,334 S | 2/1998 | Plaster et al. |
| 5,907,918 A | 6/1999 | Langevin et al. |
| 6,250,194 B1 | 6/2001 | Brandl et al. |
| 6,560,911 B2 | 5/2003 | Sharp |
| 6,598,329 B1 | 7/2003 | Alexander |
| 6,598,330 B2 | 7/2003 | Garrett et al. |
| 6,651,371 B2 | 11/2003 | Fitzpatrick et al. |
| 6,779,289 B2 | 8/2004 | Kay |
| 6,829,855 B2 | 12/2004 | Seifert |
| 6,839,998 B1 | 1/2005 | Armstrong |
| 6,874,267 B2 | 4/2005 | Fitzpatrick et al. |
| 6,925,743 B1 | 8/2005 | DiGiovanna |
| 7,104,001 B1 | 9/2006 | Digiovanna |
| 7,131,228 B2 | 11/2006 | Hochstrate et al. |
| 7,152,355 B2 | 12/2006 | Fitzpatrick et al. |
| 7,162,822 B1 | 1/2007 | Heayn et al. |
| 7,337,573 B1 | 3/2008 | Digiovanna |
| 7,398,616 B1 | 7/2008 | Weir |
| 7,418,797 B1 | 9/2008 | Crose |
| 7,428,794 B2 | 9/2008 | Oz |
| D584,373 S | 1/2009 | Young |
| D589,578 S | 3/2009 | Choma |
| D600,308 S | 9/2009 | Fitzpatrick et al. |
| 7,587,852 B1 | 9/2009 | Harms |
| D603,013 S | 10/2009 | Fitzpatrick et al. |
| D604,794 S | 11/2009 | Bentley |
| 7,610,711 B2 | 11/2009 | Oz |
| D607,078 S * | 12/2009 | Chu D22/109 |
| 7,627,975 B1 | 12/2009 | Hines |
| 7,640,688 B2 | 1/2010 | Oz |

(56) **References Cited**
U.S. PATENT DOCUMENTS

| | | |
|-------------|---------|-----------------|
| 294,402 A | 3/1884 | Onderdonk |
| 319,613 A | 6/1885 | Onderdonk |
| 436,997 A | 9/1890 | Quackenbush |
| 746,859 A | 12/1903 | Marble |
| 922,173 A | 5/1909 | Lovelace |
| 931,328 A | 8/1909 | Marble |
| 961,511 A | 6/1910 | Marble |
| 1,051,960 A | 2/1913 | Kennedy |
| 1,086,490 A | 2/1914 | Weathers |
| 1,156,293 A | 10/1915 | Jorgenson |
| 1,174,840 A | 3/1916 | Fisher |
| 1,315,215 A | 9/1919 | Davidson |
| 1,485,456 A | 3/1924 | Von Frommer |
| 1,526,847 A | 2/1925 | Fritz |
| 1,734,852 A | 11/1929 | Frampton et al. |
| 1,822,875 A | 9/1931 | Ammann |
| 2,098,139 A | 11/1937 | Foley et al. |

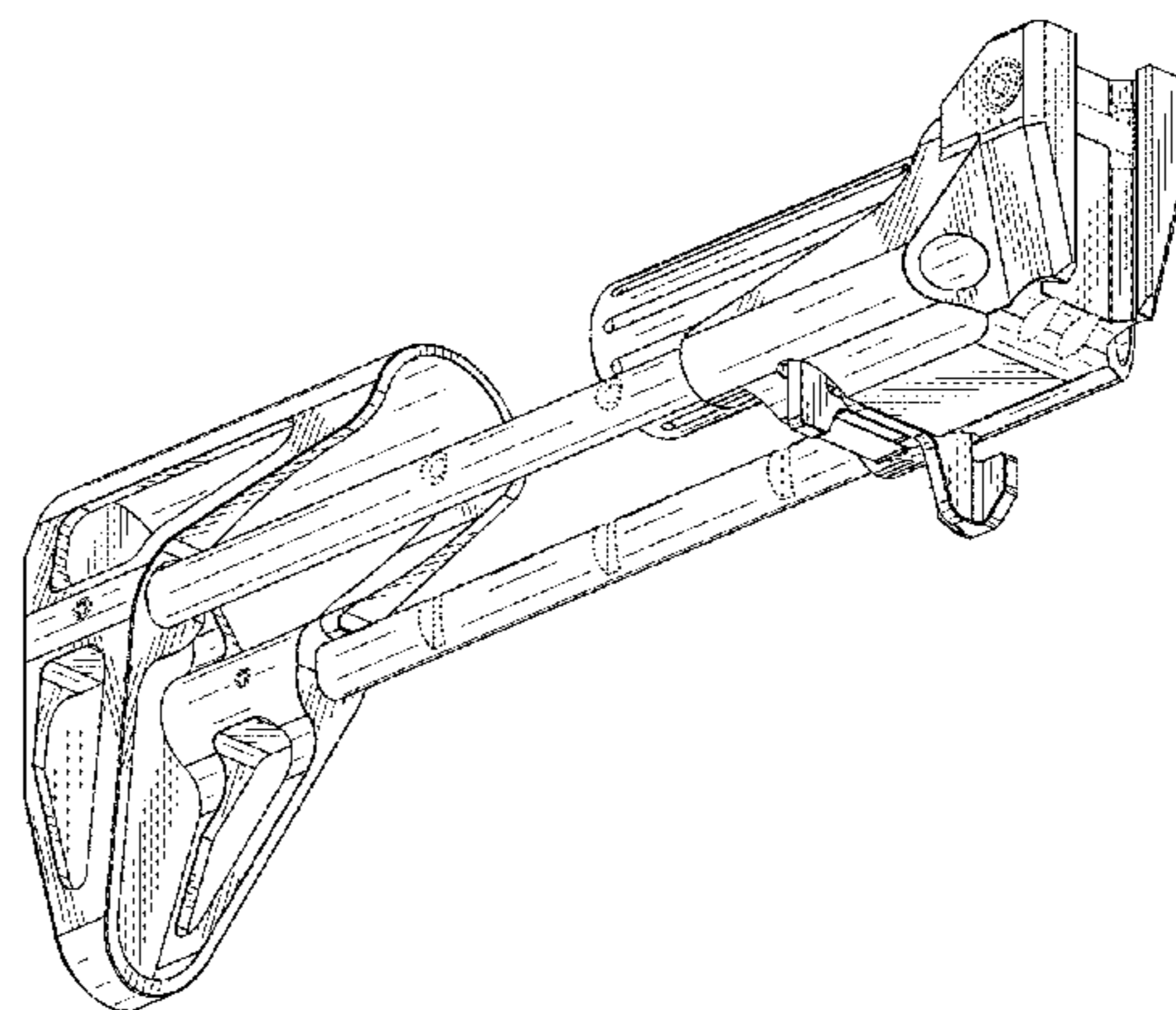
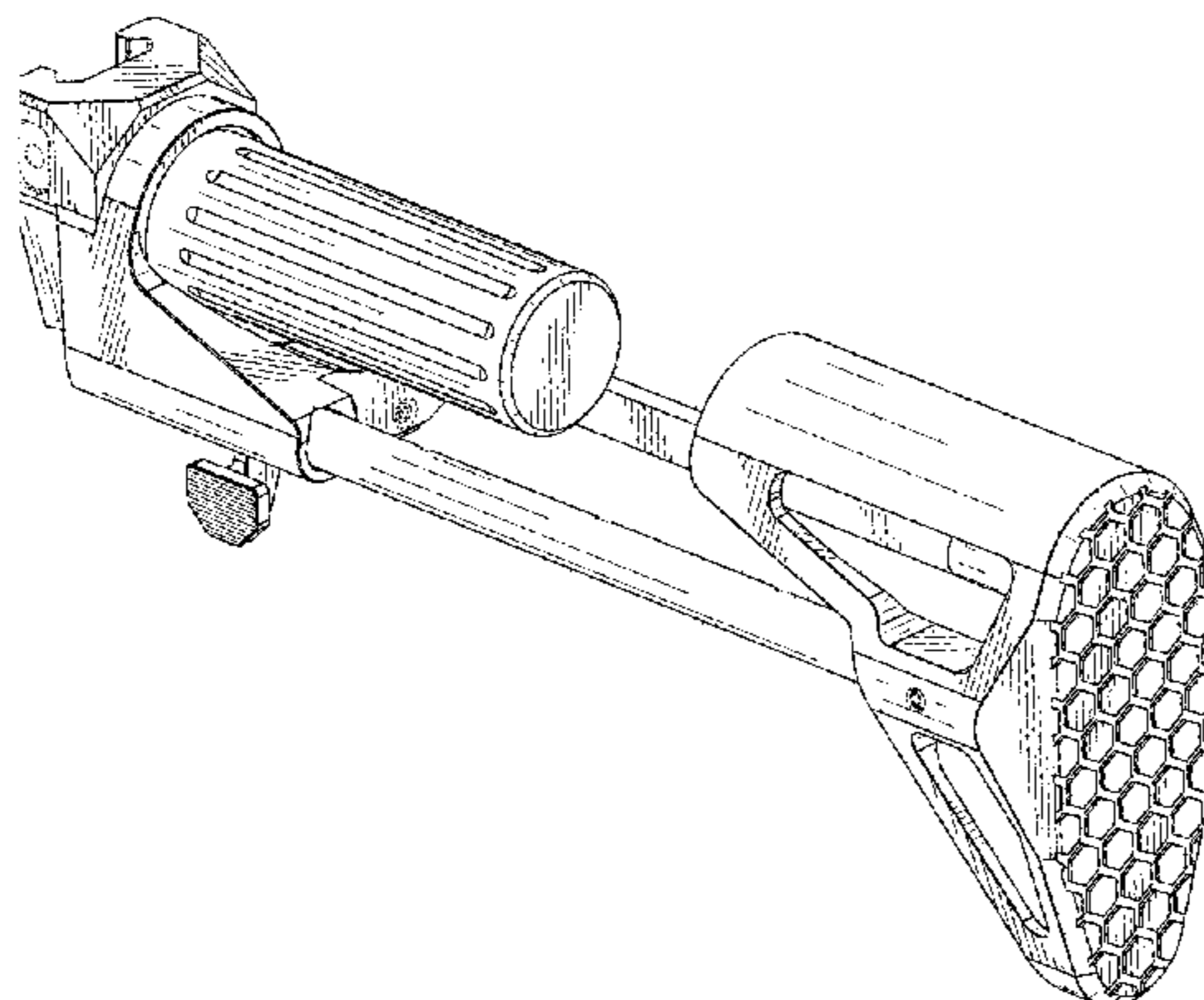

| | | | | |
|--------------|------|---------|--------------------|-----------------------|
| 7,647,719 | B2 | 1/2010 | Fitzpatrick et al. | |
| 7,654,187 | B2 | 2/2010 | Hochstrate et al. | |
| 7,681,351 | B2 | 3/2010 | Bucholtz et al. | |
| D616,056 | S | 5/2010 | Bentley | |
| 7,743,544 | B2 | 6/2010 | Laney et al. | |
| D620,067 | S | 7/2010 | Saur | |
| 7,762,018 | B1 | 7/2010 | Fitzpatrick et al. | |
| 7,775,150 | B2 | 8/2010 | Hochstrate et al. | |
| 7,805,873 | B2 | 10/2010 | Bentley | |
| 7,810,270 | B2 | 10/2010 | Fitzpatrick et al. | |
| 7,823,313 | B2 | 11/2010 | Faifer | |
| 7,827,722 | B1 | 11/2010 | Davies | |
| 7,849,626 | B2 | 12/2010 | Fluhr | |
| D631,122 | S | 1/2011 | Domagtoy | |
| D636,834 | S * | 4/2011 | Mayberry | F41C 23/04 D22/108 |
| 7,937,873 | B2 | 5/2011 | Keng | |
| D640,342 | S | 6/2011 | Fitzpatrick et al. | |
| 7,992,336 | B2 | 8/2011 | Phillips | |
| 8,061,072 | B1 | 11/2011 | Cröse | |
| 8,127,483 | B2 | 3/2012 | Kincel | |
| 8,127,485 | B2 | 3/2012 | Kincel | |
| D661,366 | S | 6/2012 | Zusman | |
| 8,191,299 | B2 | 6/2012 | Faifer | |
| D668,311 | S | 10/2012 | Rogers et al. | |
| 8,327,568 | B1 | 12/2012 | Lavergne et al. | |
| 8,341,868 | B2 | 1/2013 | Zusman | |
| D676,921 | S | 2/2013 | Fitzpatrick et al. | |
| 8,387,298 | B2 | 3/2013 | Kincel | |
| D683,808 | S | 6/2013 | Elkaim | |
| 8,555,541 | B2 | 10/2013 | Ingram | |
| D697,162 | S | 1/2014 | Faifer | |
| 8,707,603 | B2 | 4/2014 | Troy et al. | |
| 8,756,849 | B2 | 6/2014 | Troy | |
| 8,813,157 | B2 | 8/2014 | Le Leannec et al. | |
| D725,219 | S * | 3/2015 | Hirt | D22/108 |
| 8,978,284 | B1 | 3/2015 | Zusman | |
| D745,627 | S * | 12/2015 | Kielsmeier | D22/108 |
| D753,782 | S | 4/2016 | Vazquez et al. | |
| D757,883 | S | 5/2016 | Chow et al. | |
| D773,592 | S * | 12/2016 | Jones | D22/108 |
| D773,593 | S * | 12/2016 | Hopkins | D22/108 |
| 9,541,347 | B2 | 1/2017 | Maugham | |
| 9,551,549 | B1 * | 1/2017 | Chvala | F41C 23/14 |
| D779,018 | S | 2/2017 | Zayatz et al. | |
| 9,581,411 | B2 | 2/2017 | Zusman | |
| D781,392 | S | 3/2017 | Zayatz et al. | |
| D785,122 | S * | 4/2017 | Mather | D22/104 |
| D795,985 | S * | 8/2017 | Frederickson | D22/108 |
| D809,621 | S * | 2/2018 | Lam | D22/108 |
| D810,225 | S * | 2/2018 | Huang | D22/108 |
| D818,074 | S * | 5/2018 | Ding | D22/108 |
| D819,765 | S * | 6/2018 | Kafka | D22/103 |
| 10,060,699 | B1 * | 8/2018 | Hu | F41C 23/04 |
| D828,476 | S * | 9/2018 | Smith | D22/108 |
| 2003/0110675 | A1 | 6/2003 | Garrett et al. | |
| 2003/0196366 | A1 | 10/2003 | Beretta | |
| 2003/0200693 | A1 | 10/2003 | Seifert | |
| 2004/0016167 | A1 | 1/2004 | Fitzpatrick et al. | |
| 2004/0211104 | A1 | 10/2004 | Eberle | |
| 2005/0108915 | A1 | 5/2005 | Kincel | |
| 2005/0235546 | A1 | 10/2005 | Franz et al. | |
| 2005/0262752 | A1 | 12/2005 | Robinson et al. | |
| 2006/0096146 | A1 | 5/2006 | Fitzpatrick et al. | |
| 2006/0254414 | A1 | 11/2006 | Kuczynko et al. | |
| 2007/0261284 | A1 | 11/2007 | Keng | |
| 2008/0236016 | A1 | 10/2008 | Fitzpatrick et al. | |
| 2008/0236017 | A1 | 10/2008 | Fitzpatrick et al. | |
| 2008/0301994 | A1 | 12/2008 | Langevin et al. | |
| 2009/0139128 | A1 | 6/2009 | Fluhr | |
| 2009/0178325 | A1 | 7/2009 | Veilleux | |
| 2009/0241397 | A1 | 10/2009 | Fitzpatrick et al. | |
| 2009/0255161 | A1 | 10/2009 | Fitzpatrick et al. | |
| 2010/0115817 | A1 | 5/2010 | Faifer | |
| 2010/0180485 | A1 | 7/2010 | Cabahug et al. | |
| 2010/0192444 | A1 | 8/2010 | Cabahug et al. | |
| 2010/0192446 | A1 | 8/2010 | Darian | |
| 2010/0192447 | A1 | 8/2010 | Cabahug et al. | |
| 2010/0205846 | A1 | 8/2010 | Fitzpatrick et al. | |

| | | | | |
|--------------|------|---------|-------------------|---------------------|
| 2010/0229444 | A1 | 9/2010 | Faifer | |
| 2010/0251591 | A1 | 10/2010 | Burt et al. | |
| 2010/0275489 | A1 | 11/2010 | Cabahug et al. | |
| 2010/0300277 | A1 | 12/2010 | Hochstrate et al. | |
| 2011/0099872 | A1 | 5/2011 | Bentley | |
| 2011/0173863 | A1 | 7/2011 | Ingram | |
| 2011/0192067 | A1 | 8/2011 | Troy | |
| 2012/0000108 | A1 | 1/2012 | Zusman | |
| 2012/0042556 | A1 | 2/2012 | Vesligaj | |
| 2012/0079752 | A1 | 4/2012 | Peterson et al. | |
| 2012/0131829 | A1 | 5/2012 | Fistikchi | |
| 2012/0174455 | A1 | 7/2012 | Edelman et al. | |
| 2012/0174456 | A1 | 7/2012 | DePierro et al. | |
| 2012/0174457 | A1 | 7/2012 | Edelman | |
| 2012/0180353 | A1 | 7/2012 | Holmberg | |
| 2013/0180148 | A1 | 7/2013 | Rogers et al. | |
| 2014/0223791 | A1 | 8/2014 | Ruby et al. | |
| 2015/0176943 | A1 | 6/2015 | Iervolino | |
| 2016/0116249 | A1 * | 4/2016 | Maugham | F41C 23/04 42/74 |
| 2016/0178314 | A1 * | 6/2016 | Kielsmeier | F41C 23/14 42/73 |
| 2016/0305738 | A1 * | 10/2016 | Huang | F41C 23/04 |
| 2018/0356184 | A1 * | 12/2018 | Chambers | F41C 23/22 |

FOREIGN PATENT DOCUMENTS

WO WO 2008/097308 A2 8/2008

OTHER PUBLICATIONS

JPRifles, Maxim Defense Stock Preview, posted at YouTube, posting date Oct. 8, 2015. [Site visited Sep. 20, 2018] URL: <https://www.youtube.com/watch?v=EYtfJeNO1_0> (Year: 2015).*

Shelton, Elwood, Troy Introduces M7A1 PDW Collapsible Stock as Kit, posted at Gun Digest, posting date Dec. 4, 2014. [Site visited Sep. 20, 2018] URL: <<https://gundigest.com/reviews/troy-introduces-m7a1-pdw-collapsible-stock-as-kit>> (Year: 2014).*

APS Collapsible Rifle Stock CRS BK, posted at Amazon, posting date not available. [Site visited Sep. 20, 2018] URL: <<https://www.amazon.co.jp/APS-Collapsible-%E3%83%A9%E3%82%A4%E3%83%95%E3%83%AB%E3%82%B9%E3%83%88%E3%83%83%E3%82%AF-CRS-BK/dp/B07C3QQS6R>>.*

The Maxim Defense CQB Stock—AR15, Product Sheet, May 14, 2016, pp. 2, Maxim Defense Industries, LLC, St. Cloud, MN.

The Maxim Defense CQB Pistol EXC, Product Sheet, Sep. 6, 2016, pp. 2, Maxim Defense Industries, LLC, St. Cloud, MN.

The Maxim CQB Pistol: PDW Brace, Product Sheet, Oct. 19, 2016, pp. 2, Maxim Defense Industries, LLC, St. Cloud, MN.

The Maxim Defense CQB Stock, Product Sheet, Oct. 28, 2015, p. 1, Maxim Defense Industries, LLC, St. Cloud, MN.

Locarno (International Designs) search results: Jan. 10, 2011, pp. 1-16.

* cited by examiner

Primary Examiner — Kevin K Rudzinski
 Assistant Examiner — Kathleen L Jones
 (74) Attorney, Agent, or Firm — Law Office of Arthur M. Antonelli, PLLC

(57) CLAIM

The ornamental design for a stock for a gun, as shown and described.

DESCRIPTION

FIG. 1 is a perspective view of a first embodiment of a stock for a gun in accordance with my new design, the stock for a gun being in a fully deployed configuration;

FIG. 2 is a front, left, bottom perspective view of the stock for a gun of FIG. 1;
FIG. 3 is a front view of the stock for a gun of FIG. 1;
FIG. 4 is a rear view of the stock for a gun of FIG. 1;
FIG. 5 is a left side view of the stock for a gun of FIG. 1;
FIG. 6 is a right side view of the stock for a gun of FIG. 1;
FIG. 7 is a top view of the stock for a gun of FIG. 1;
FIG. 8 is a bottom view of the stock for a gun of FIG. 1;
FIG. 9 is another perspective view of the first embodiment of a stock for a gun of FIG. 1, the stock for a gun being in a collapsed configuration;
FIG. 10 is a front, left, bottom perspective view of the stock for a gun of FIG. 9;
FIG. 11 is a front view of the stock for a gun of FIG. 9;
FIG. 12 is a rear view of the stock for a gun of FIG. 9;
FIG. 13 is a left side view of the stock for a gun of FIG. 9;
FIG. 14 is a right side view of the stock for a gun of FIG. 9;
FIG. 15 is a top view of the stock for a gun of FIG. 9;
FIG. 16 is a bottom view of the stock for a gun of FIG. 9;
FIG. 17 is a perspective view of a second embodiment of a stock for a gun in accordance with my new design, the stock for a gun being in a fully deployed configuration;
FIG. 18 is a front, left, bottom perspective view of the stock for a gun of FIG. 17;

FIG. 19 is a front view of the stock for a gun of FIG. 17;
FIG. 20 is a rear view of the stock for a gun of FIG. 17;
FIG. 21 is a left side view of the stock for a gun of FIG. 17;
FIG. 22 is a right side view of the stock for a gun of FIG. 17;
FIG. 23 is a top view of the stock for a gun of FIG. 17;
FIG. 24 is a bottom view of the stock for a gun of FIG. 17;
FIG. 25 is another perspective view of the second embodiment of a stock for a gun of FIG. 17, the stock for a gun being in a collapsed configuration;
FIG. 26 is a front, left, bottom perspective view of the stock for a gun of FIG. 25;
FIG. 27 is a front view of the stock for a gun of FIG. 25;
FIG. 28 is a rear view of the stock for a gun of FIG. 25;
FIG. 29 is a left side view of the stock for a gun of FIG. 25;
FIG. 30 is a right side view of the stock for a gun of FIG. 25;
FIG. 31 is a top view of the stock for a gun of FIG. 25; and,
FIG. 32 is a bottom view of the stock for a gun of FIG. 25.
The broken lines immediately adjacent the shaded areas represent the bounds of the claimed design. All broken lines are directed to environment and are for illustrative purposes only and form no part of the claimed design.

1 Claim, 24 Drawing Sheets

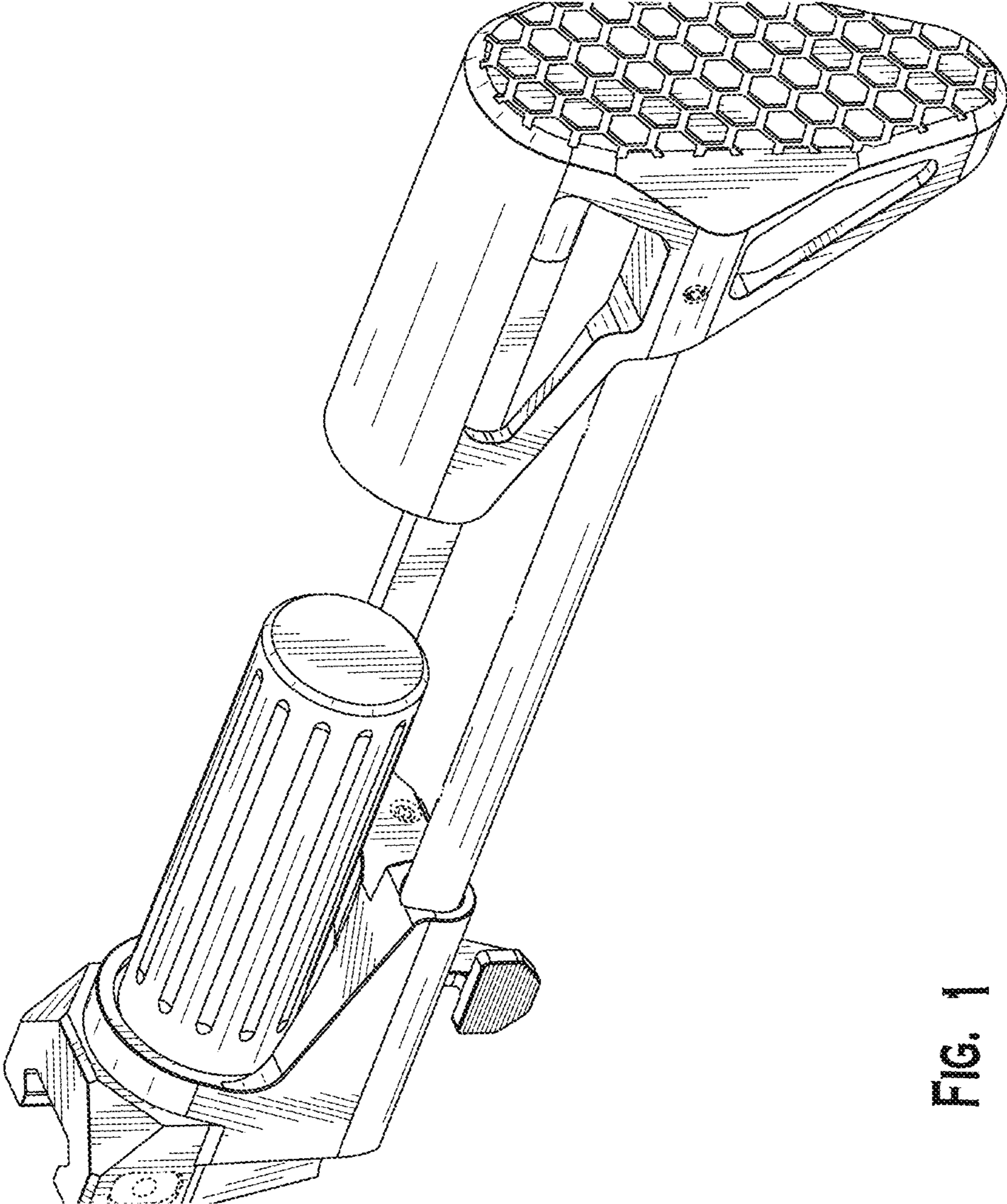

FIG. 1

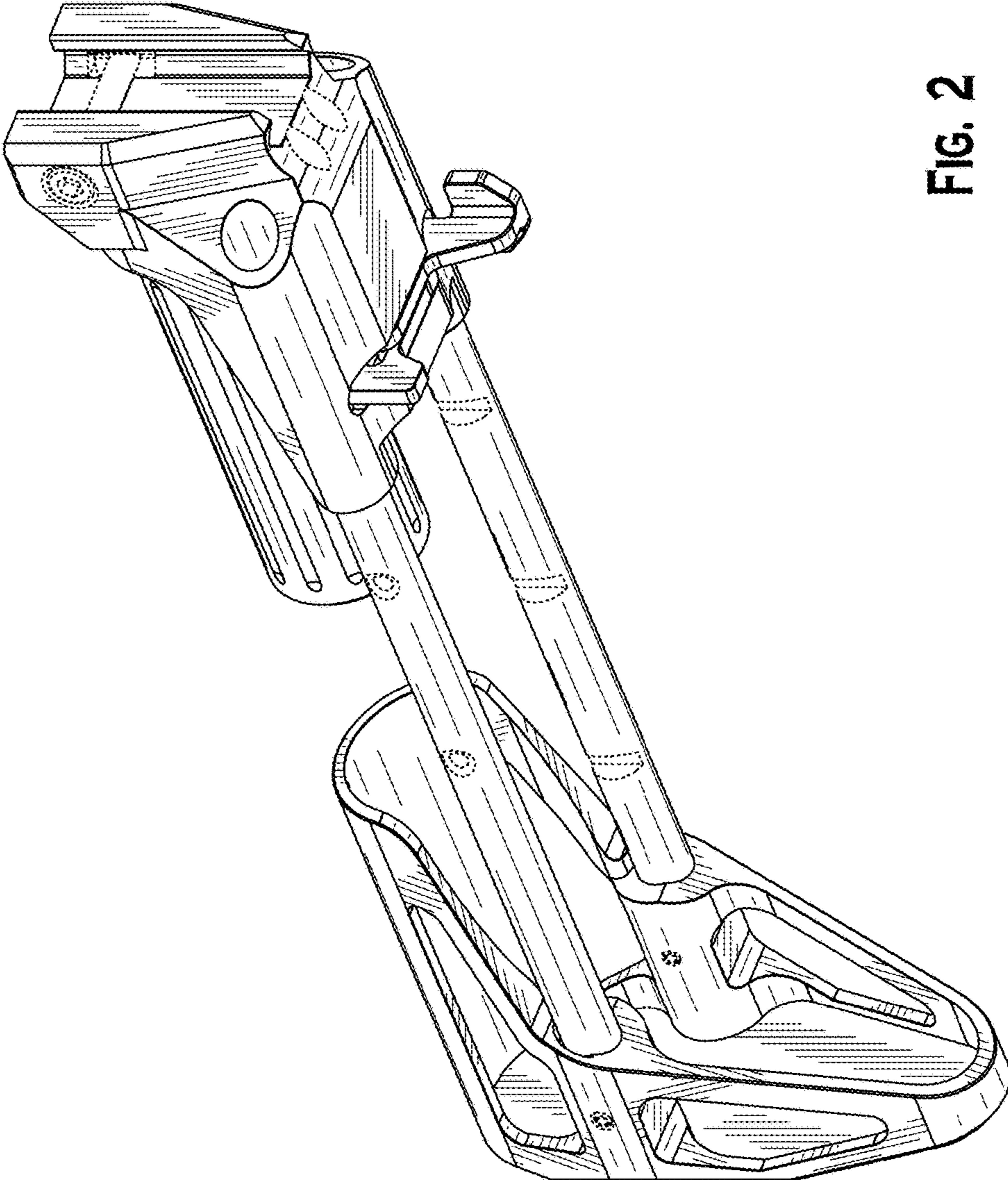

FIG. 2

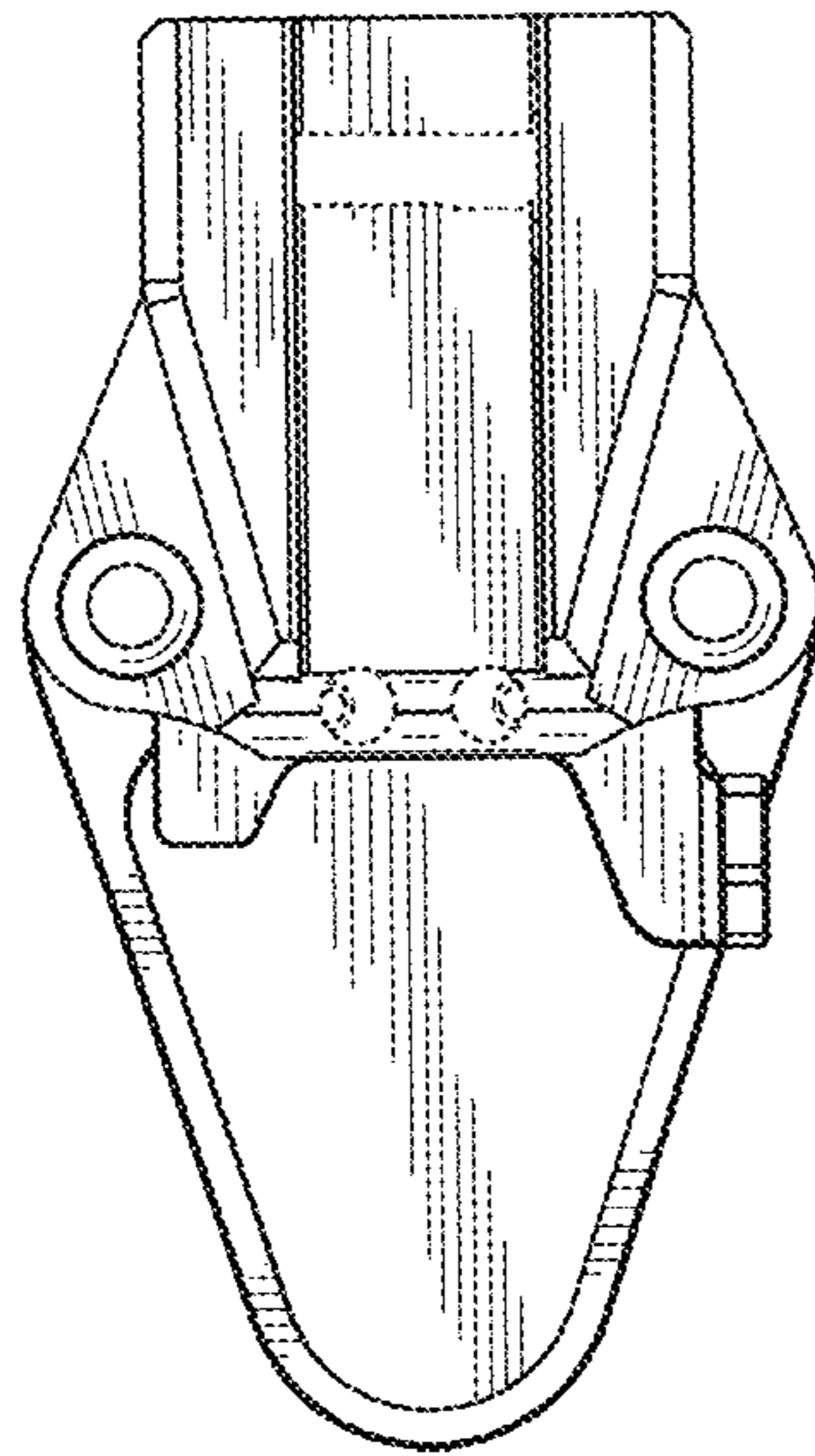

FIG. 3

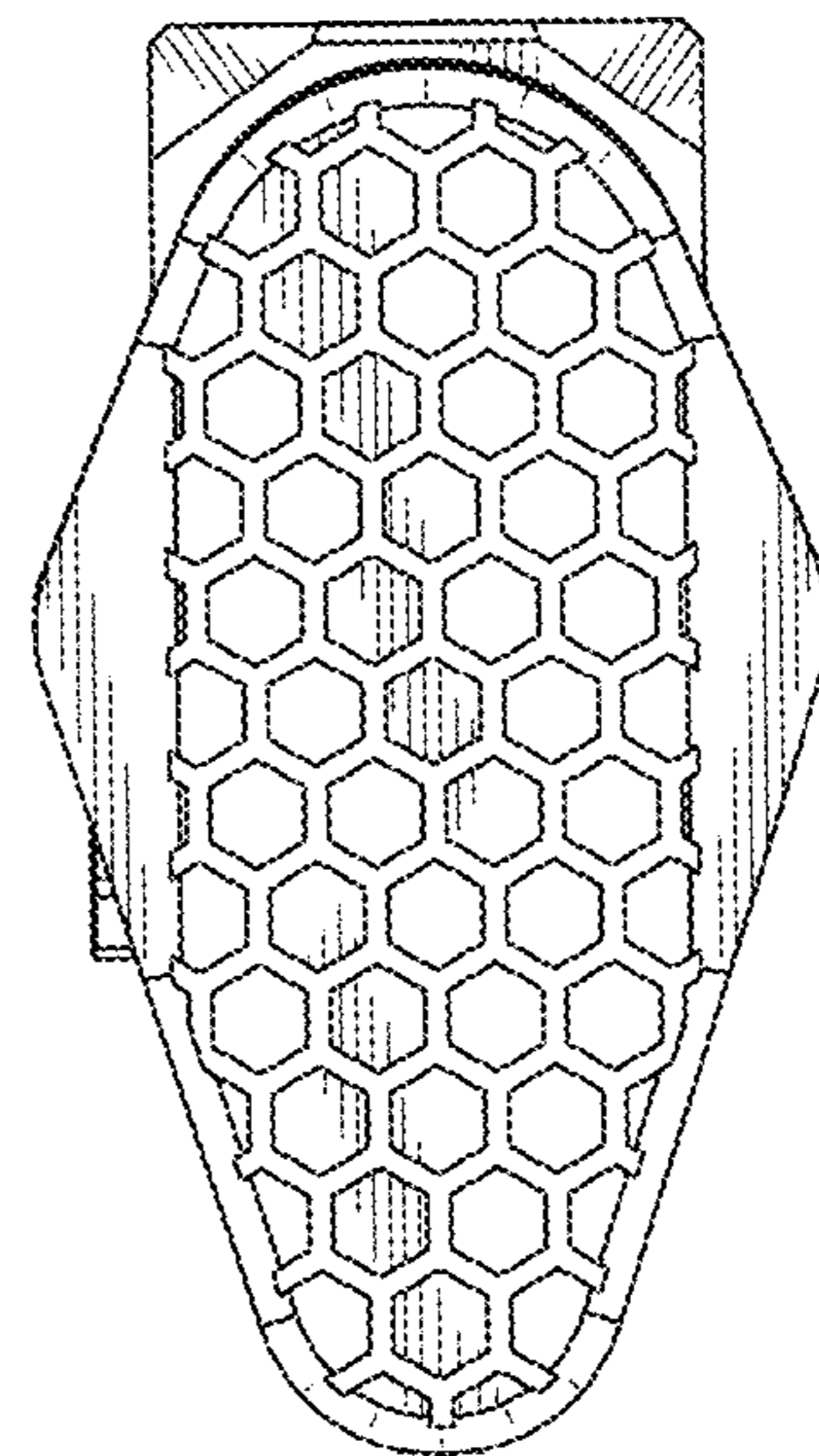

FIG. 4

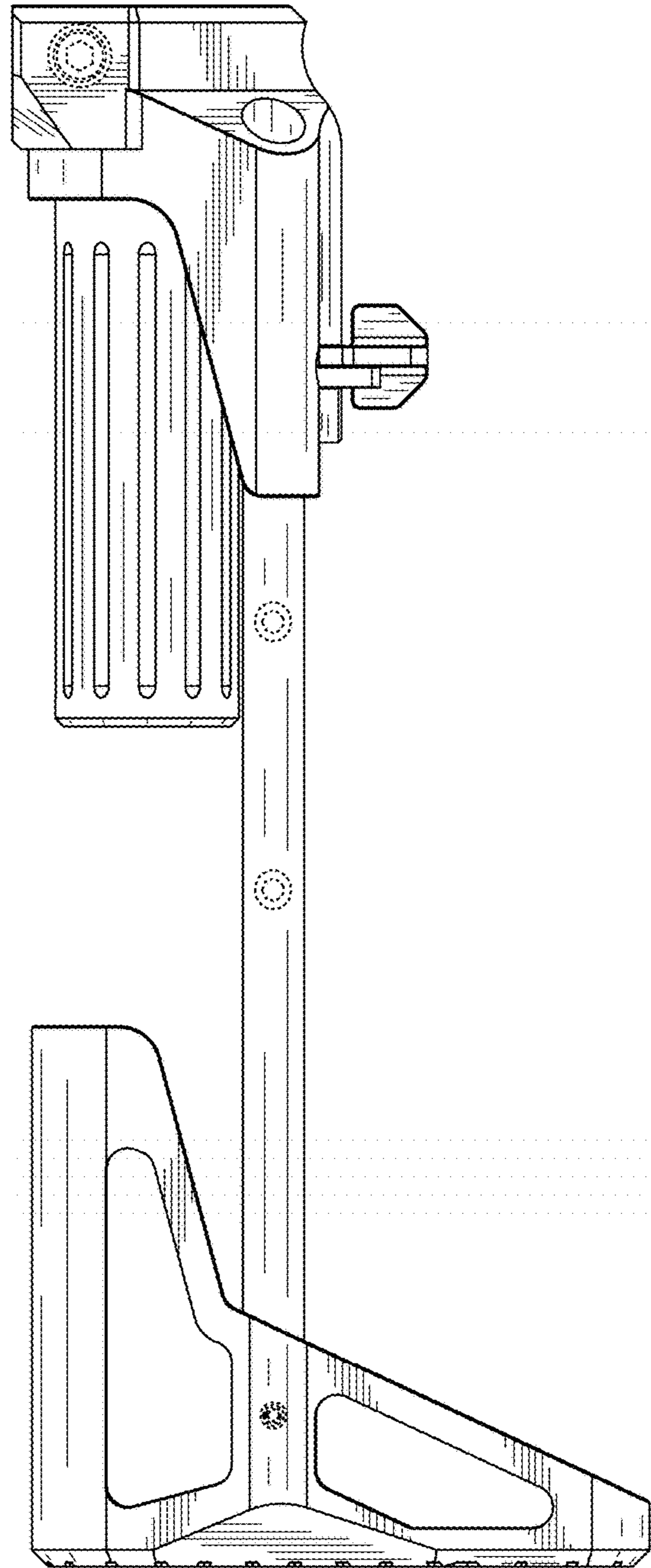

FIG. 5

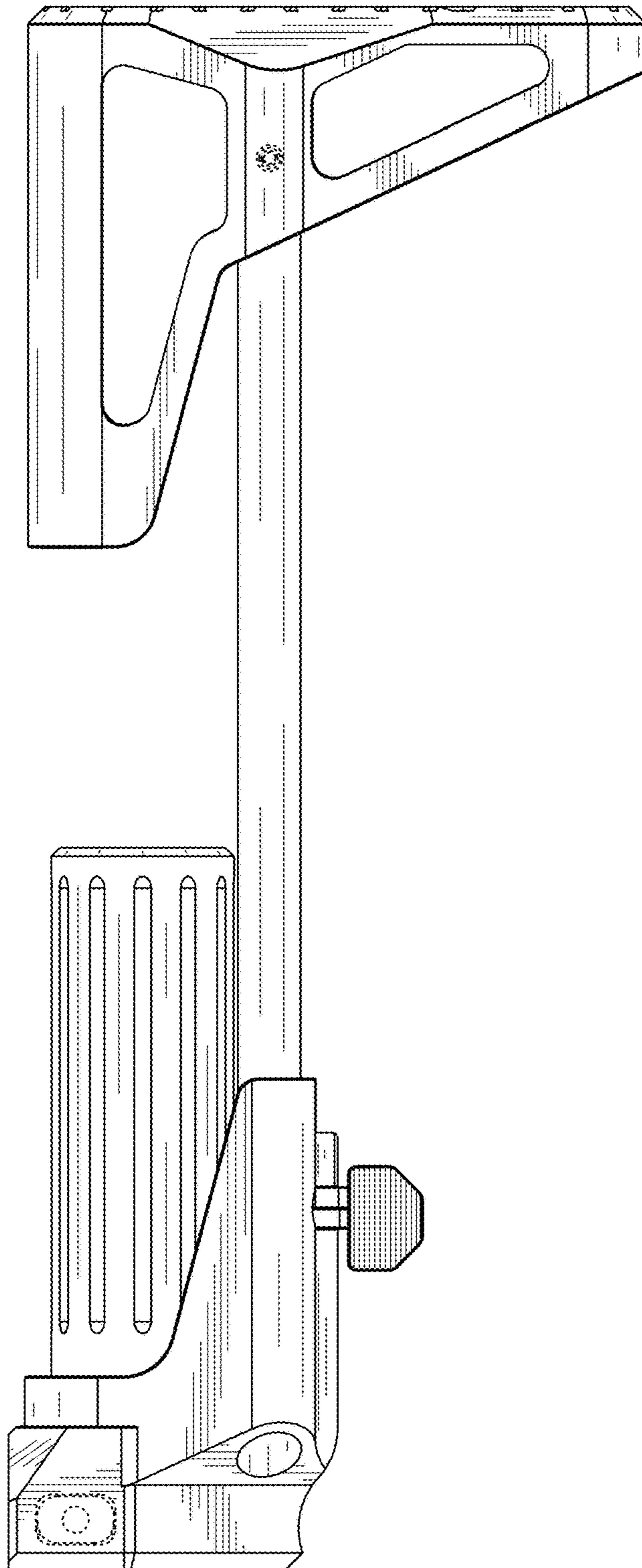

FIG. 6

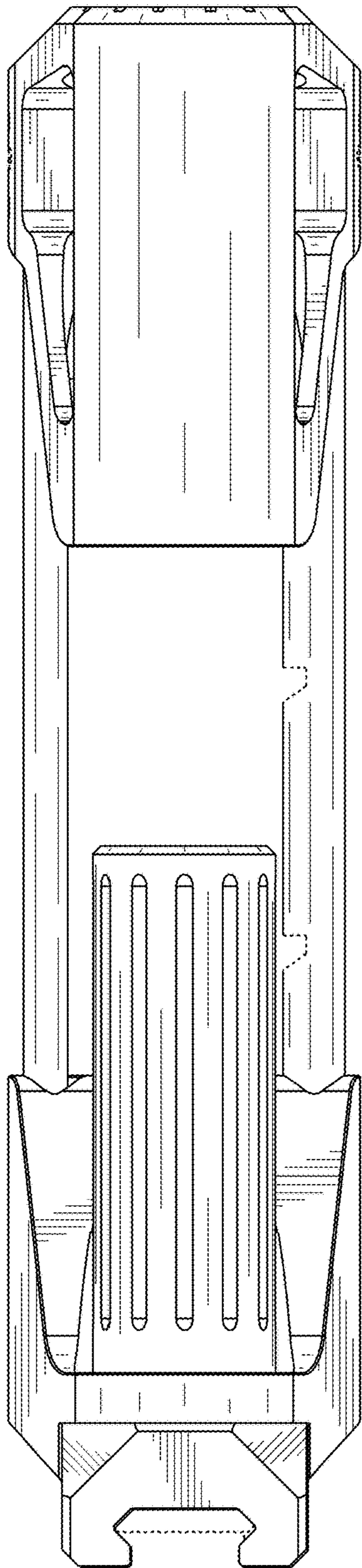

FIG. 7

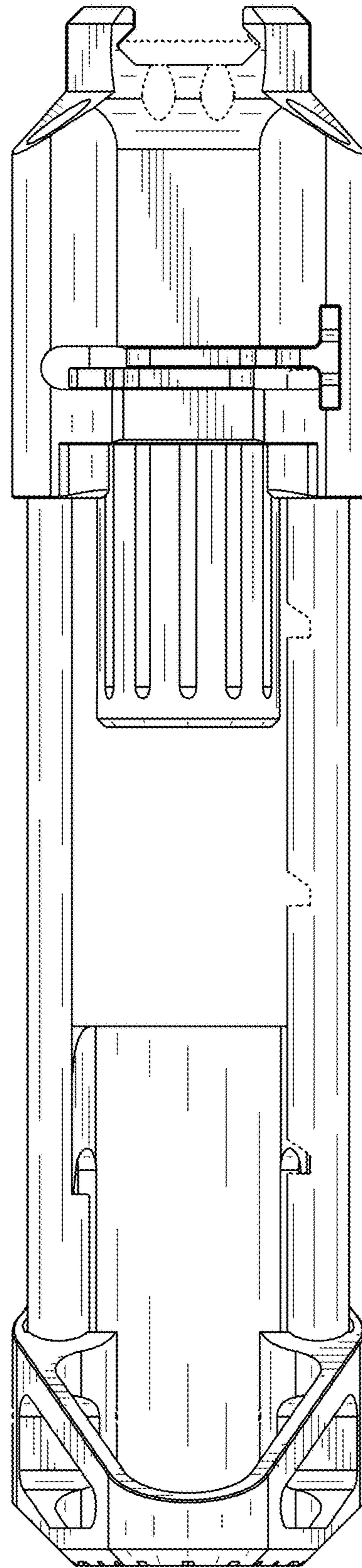

FIG. 8

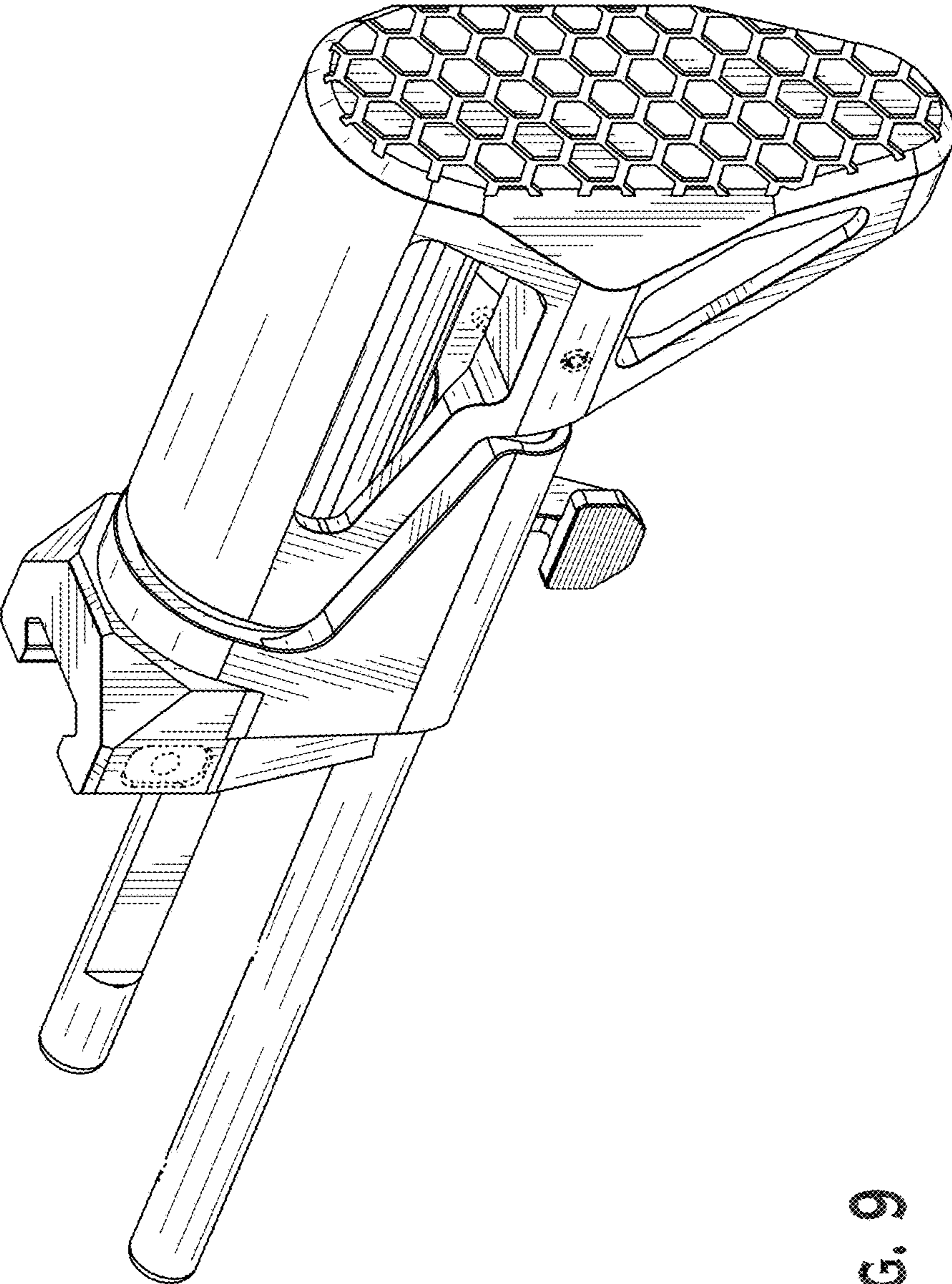

FIG. 9

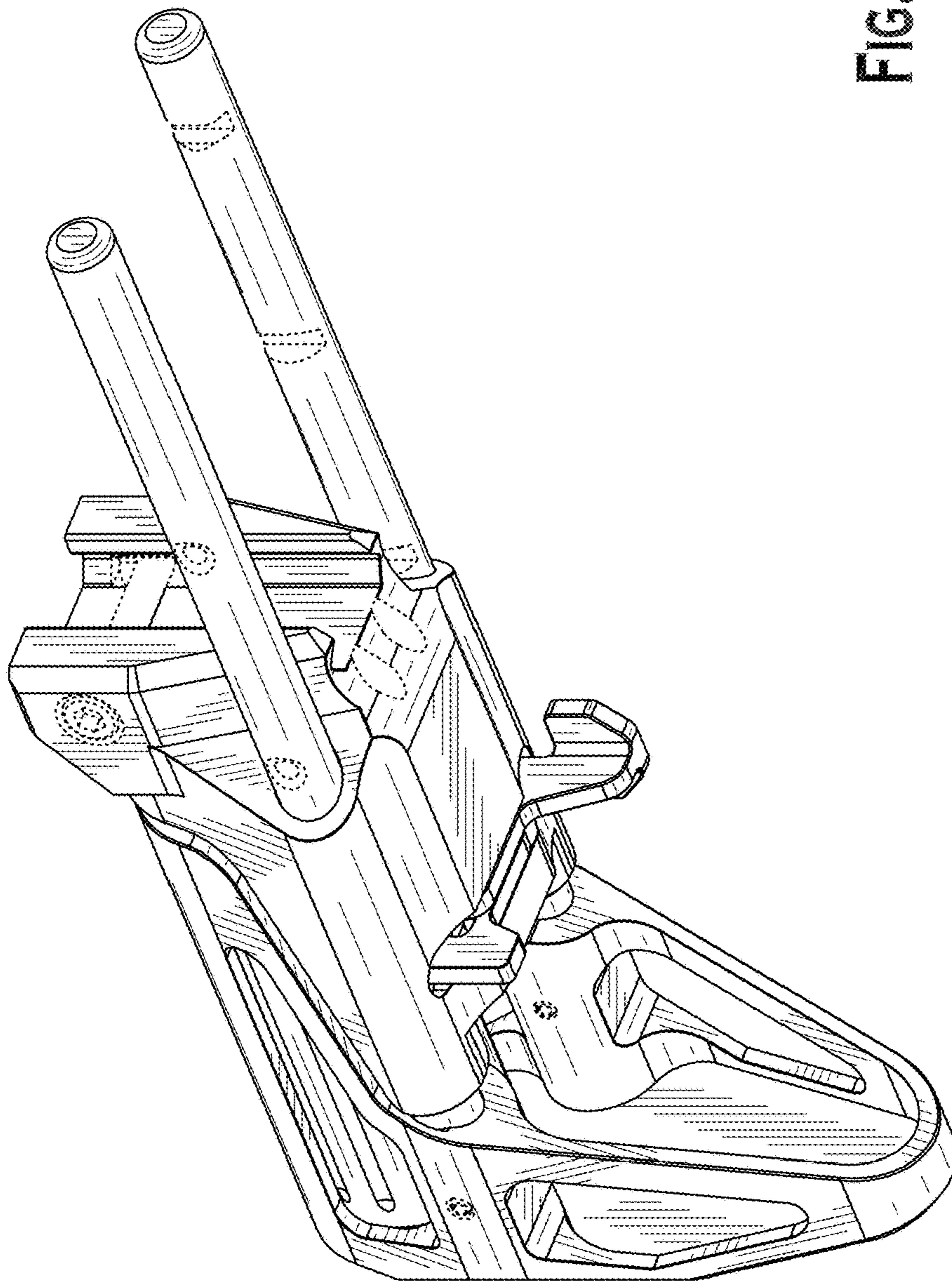

FIG. 10

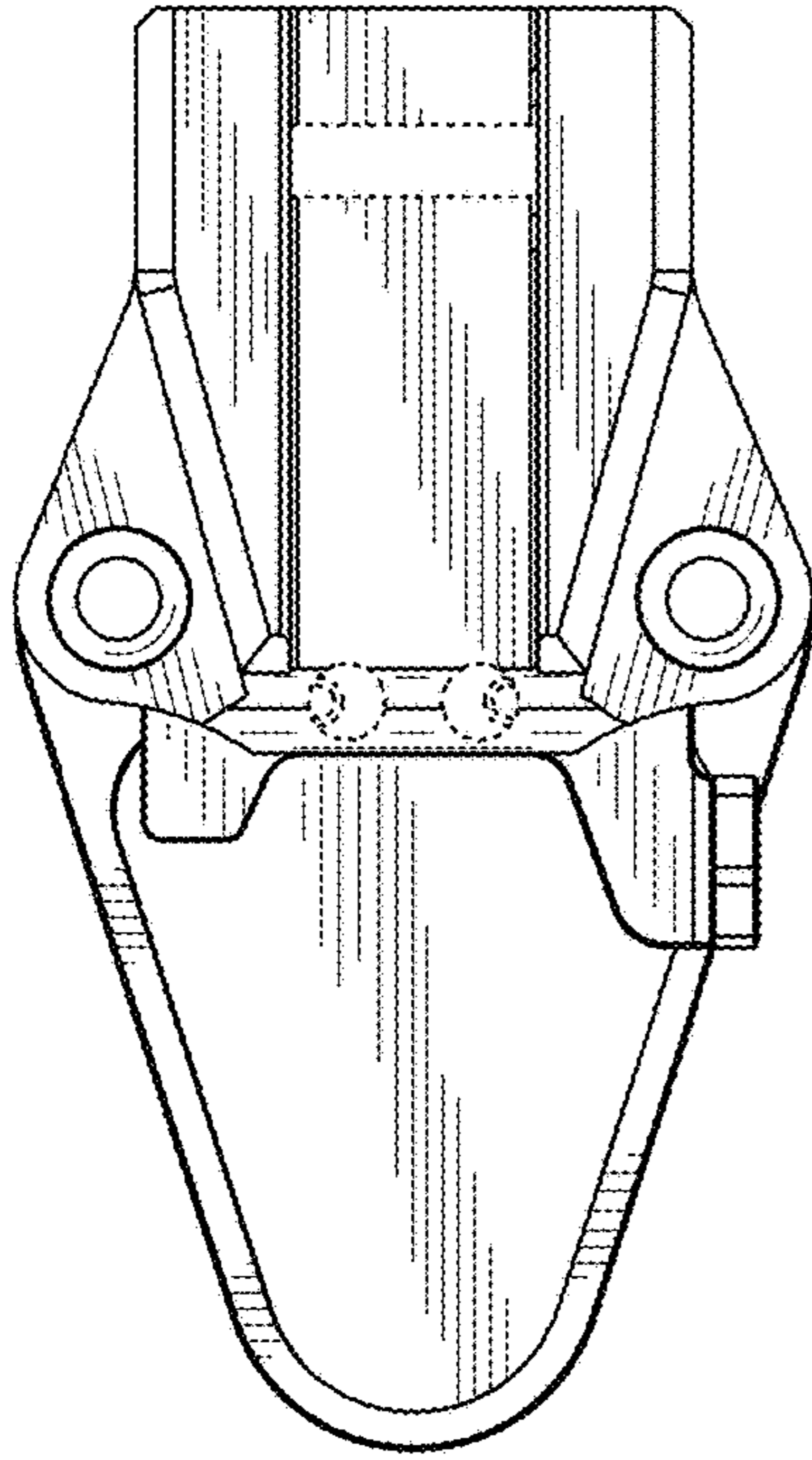

FIG. 11

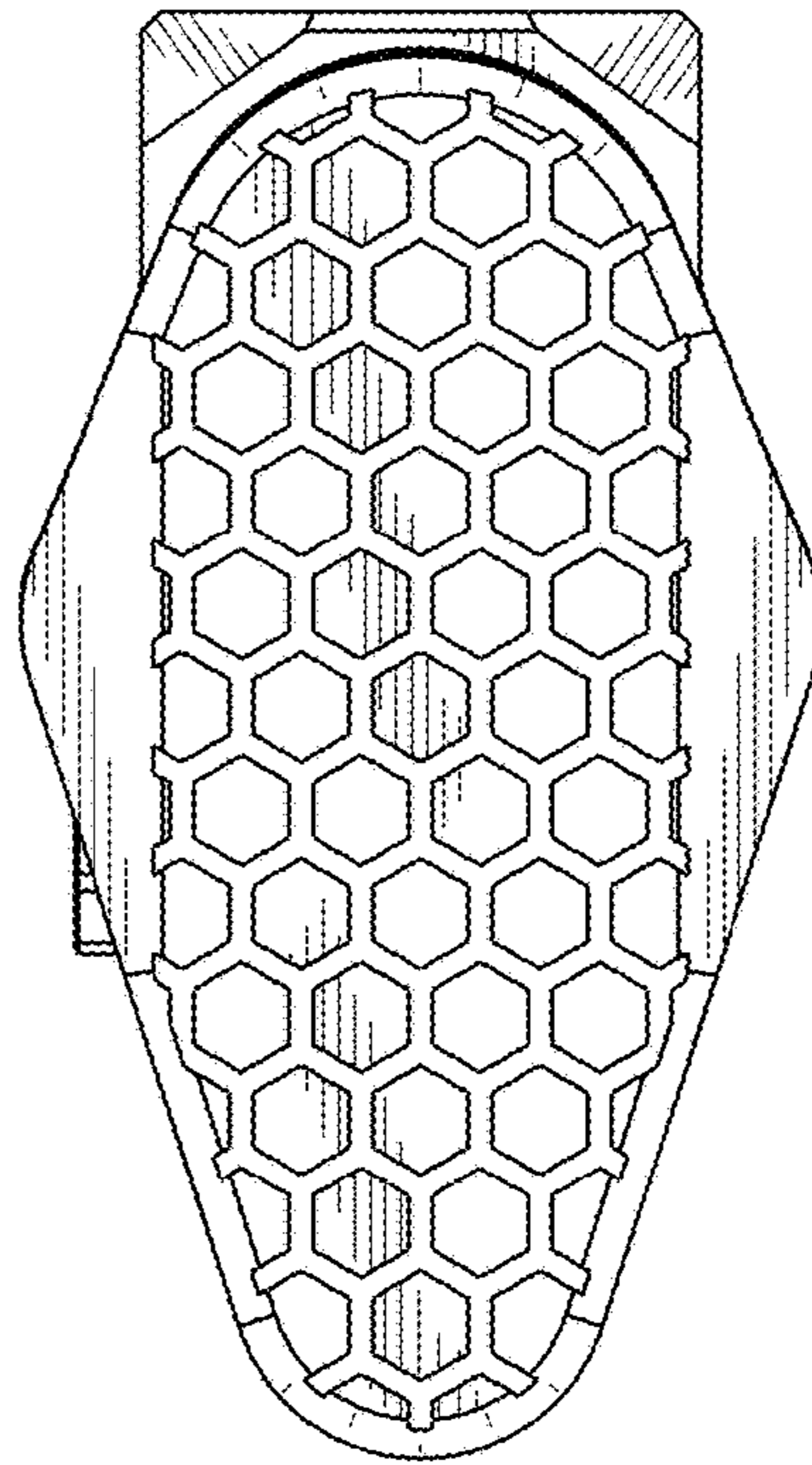

FIG. 12

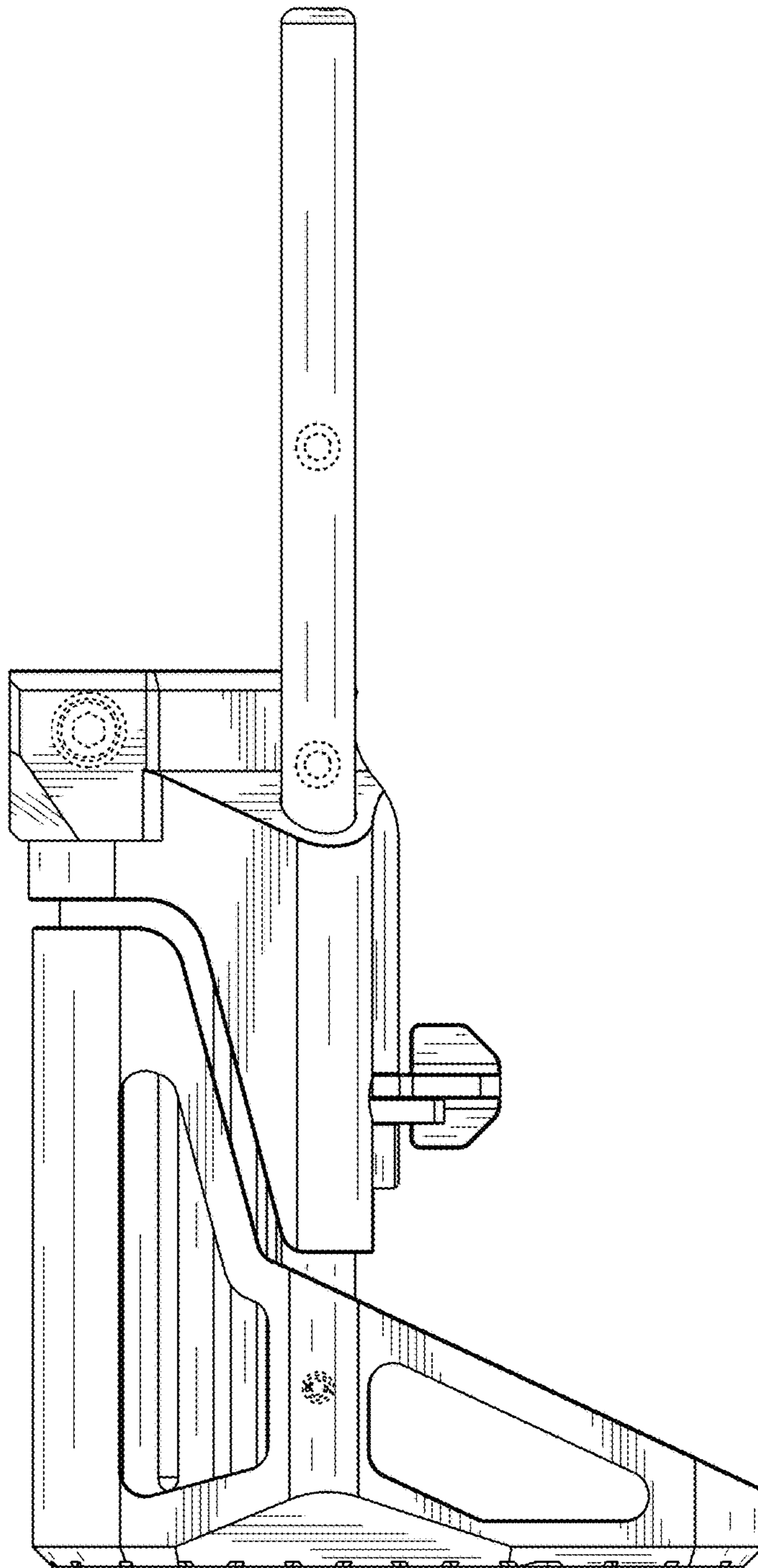

FIG. 13

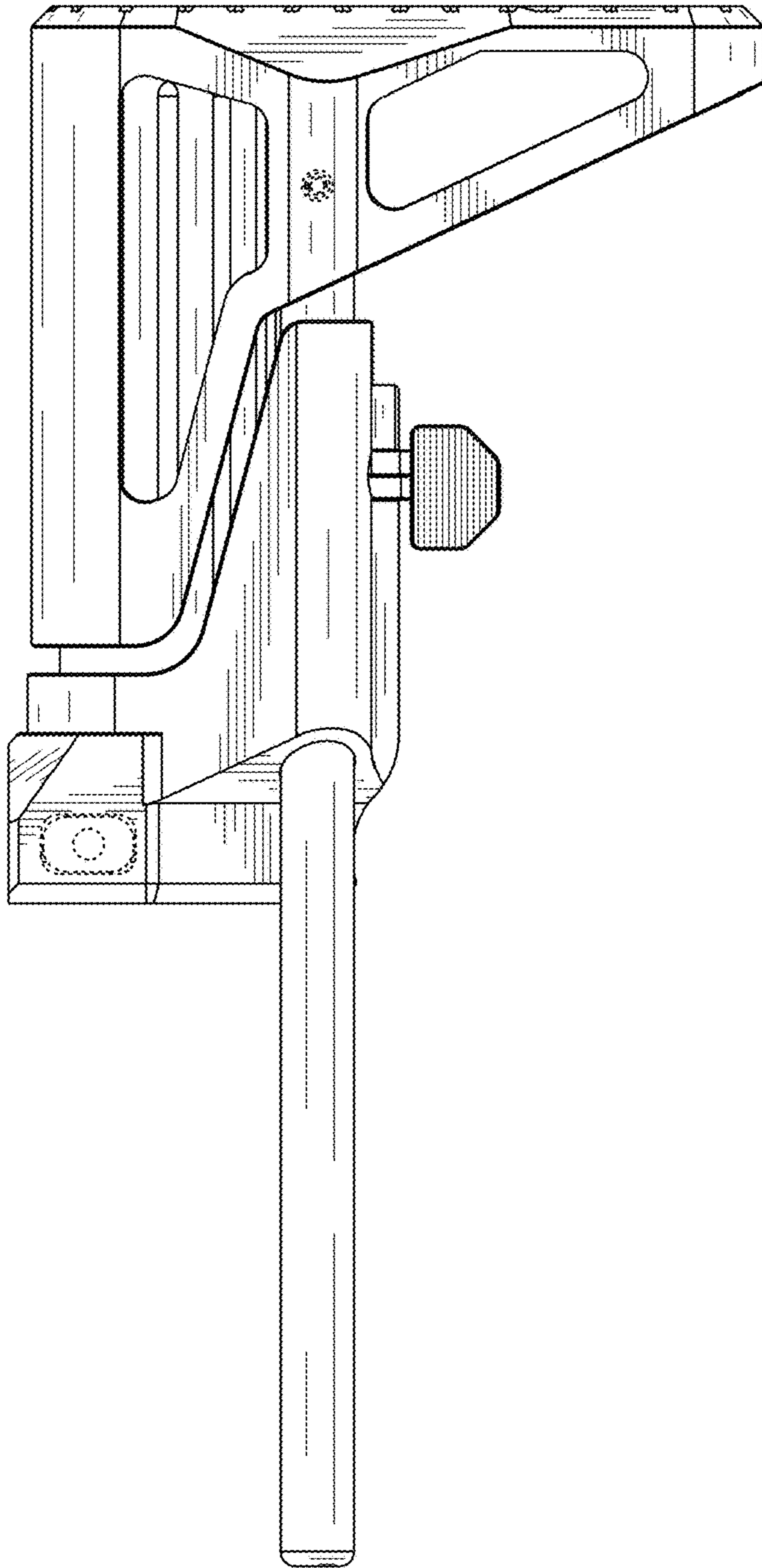

FIG. 14

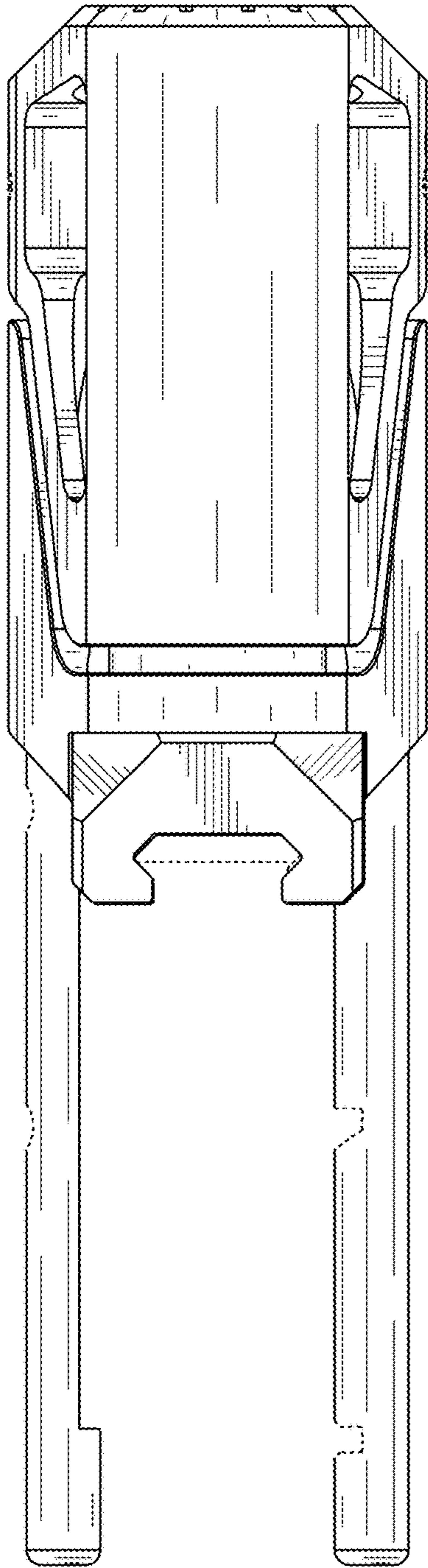

FIG. 15

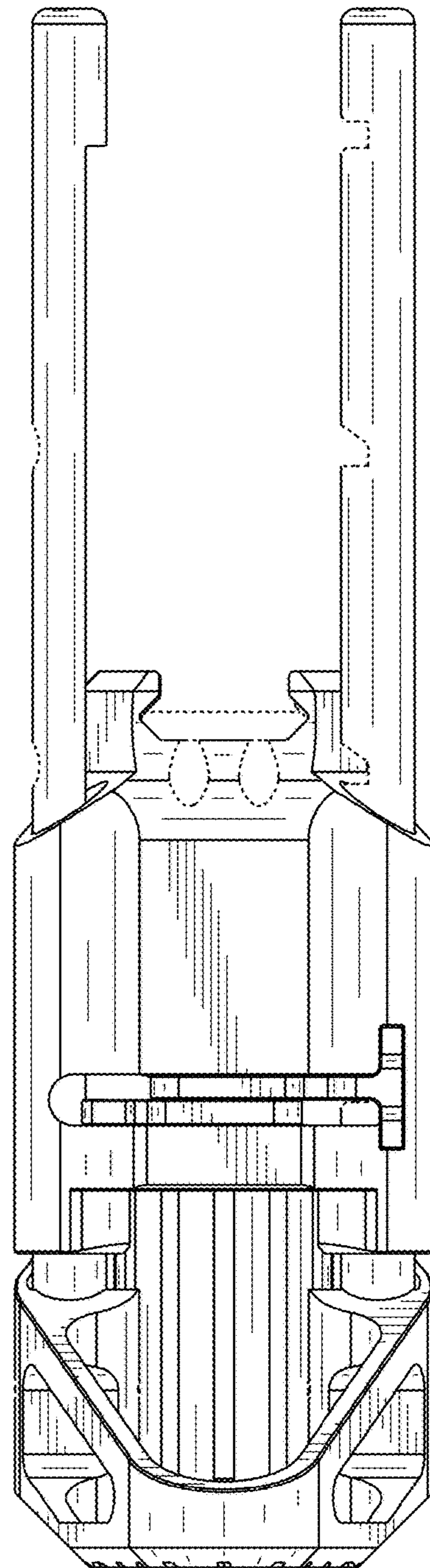

FIG. 16

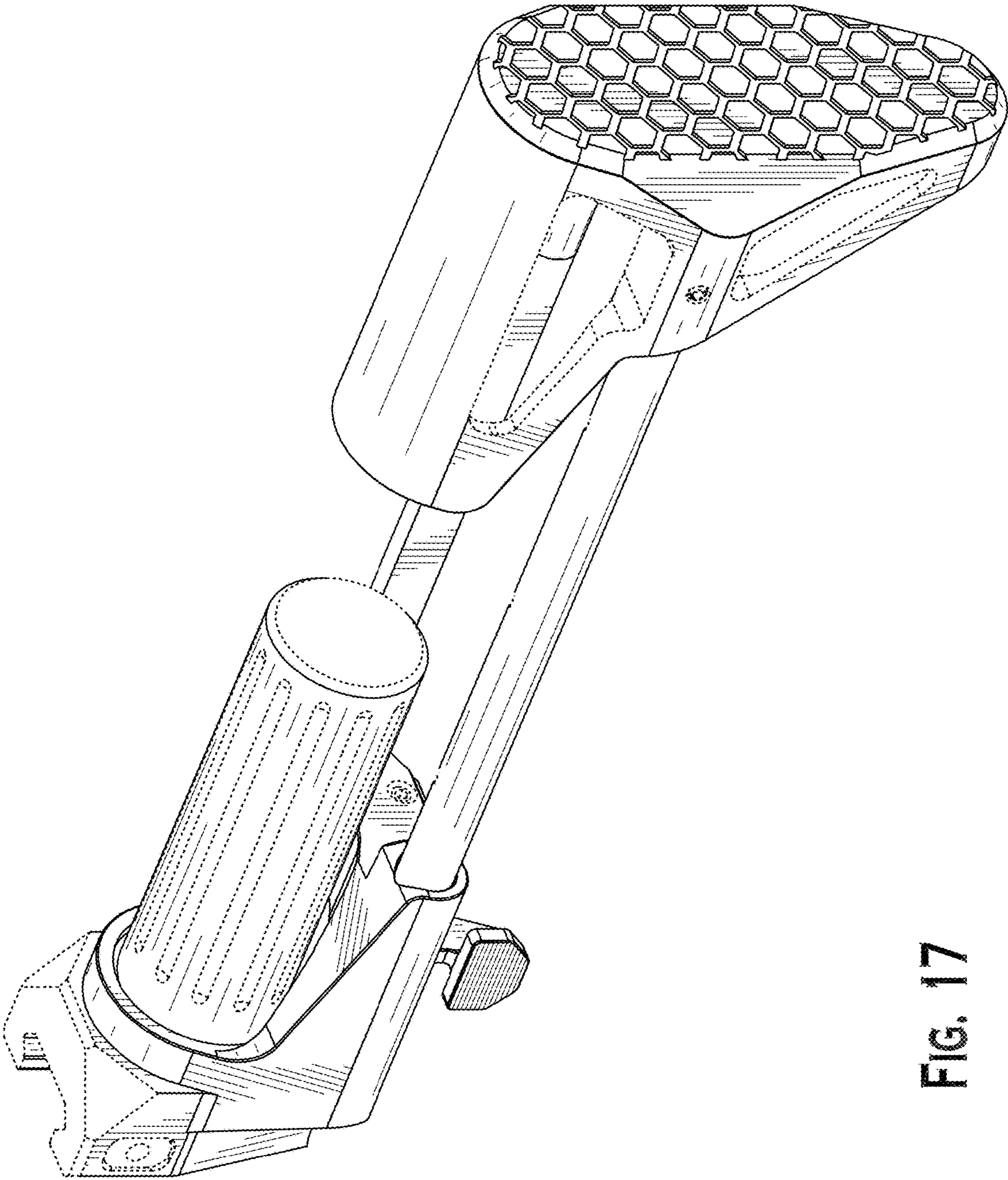

FIG. 17

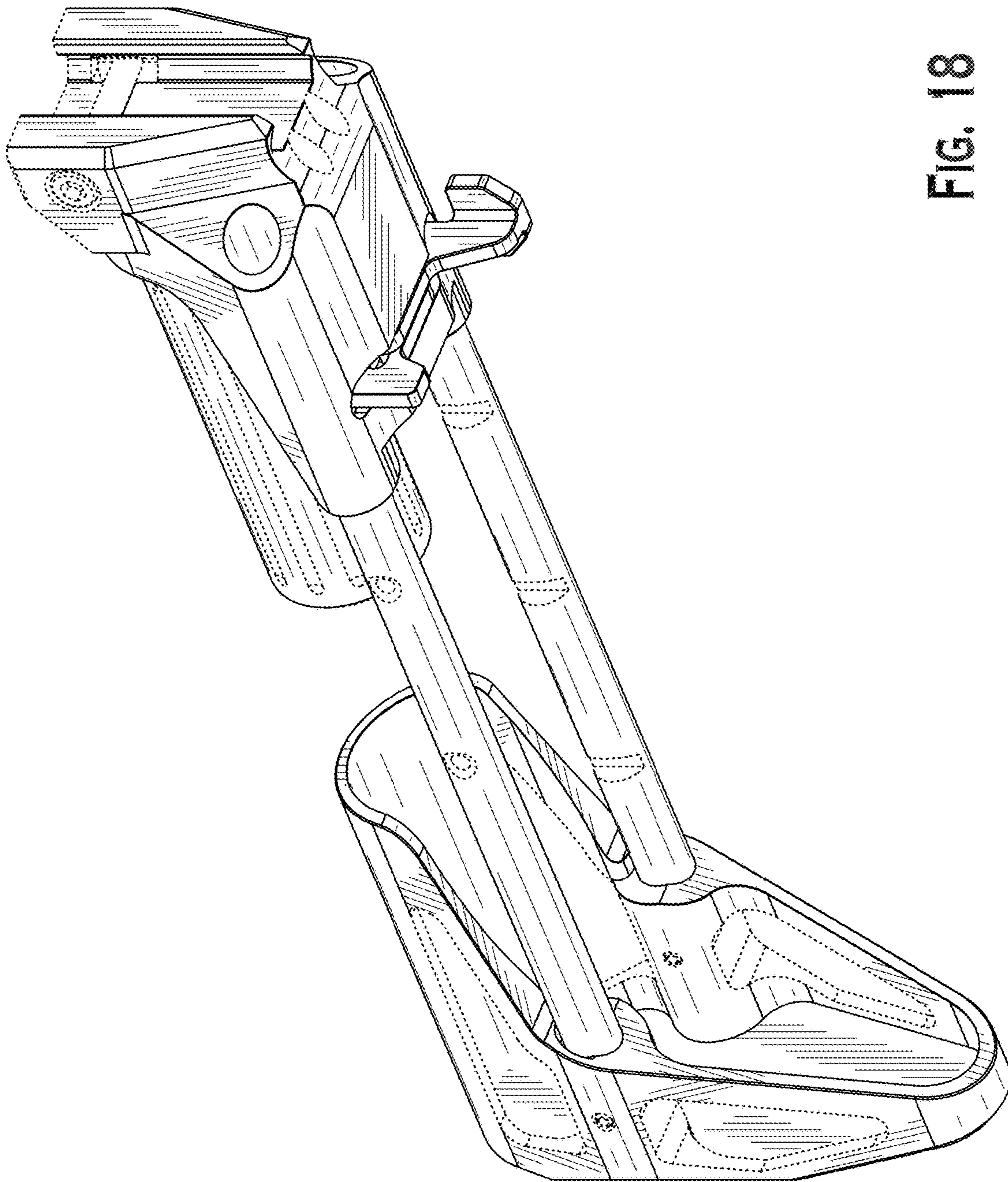

FIG. 18

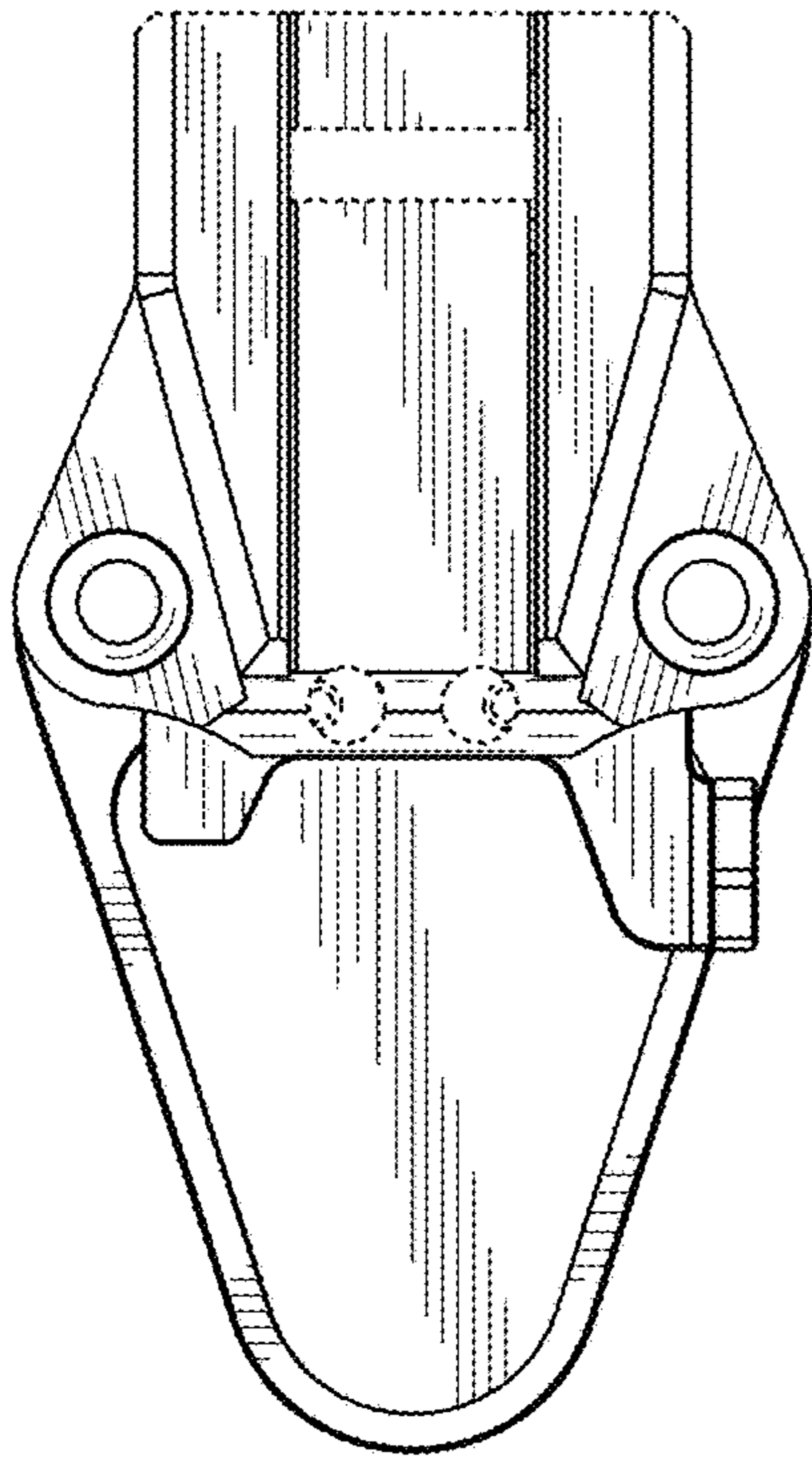

FIG. 19

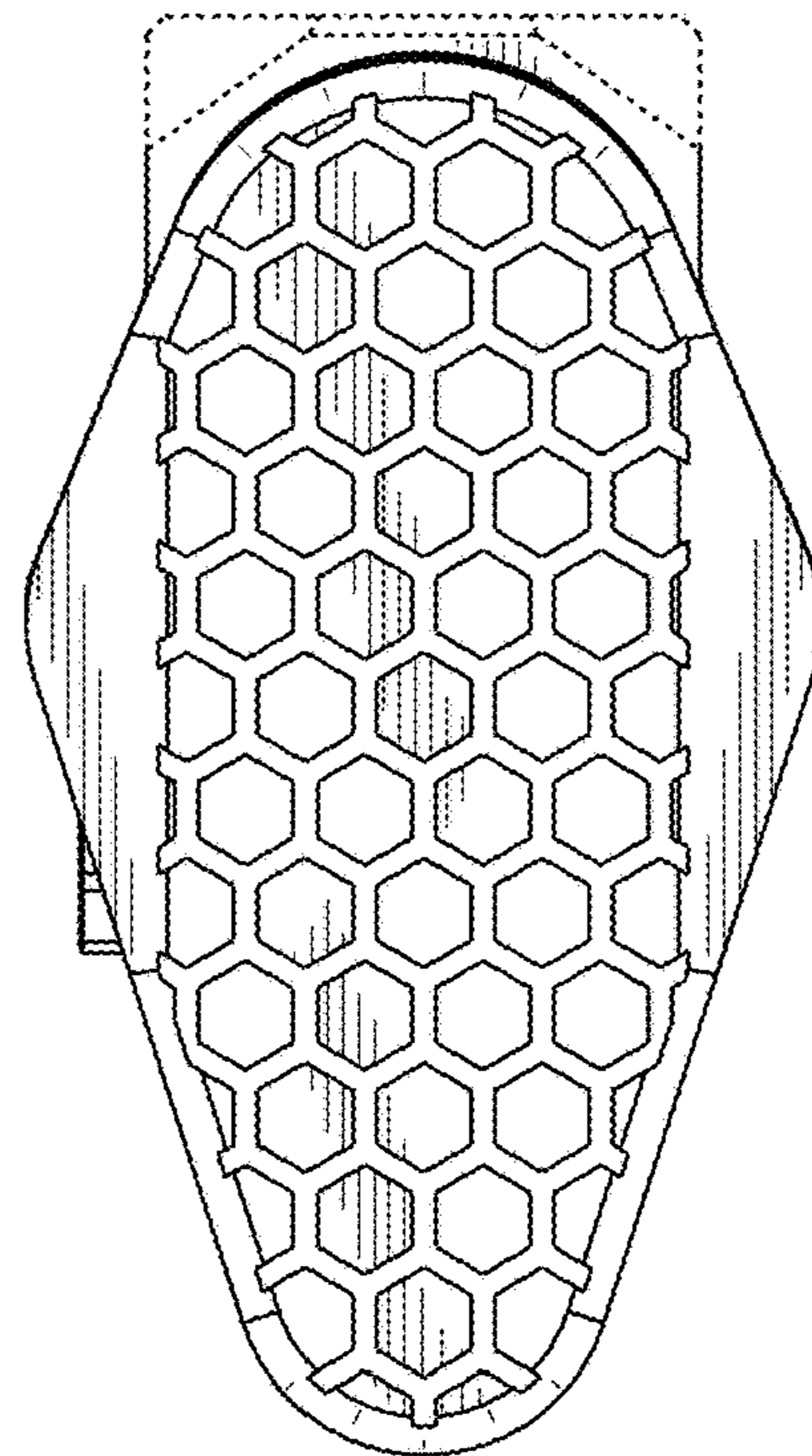

FIG. 20

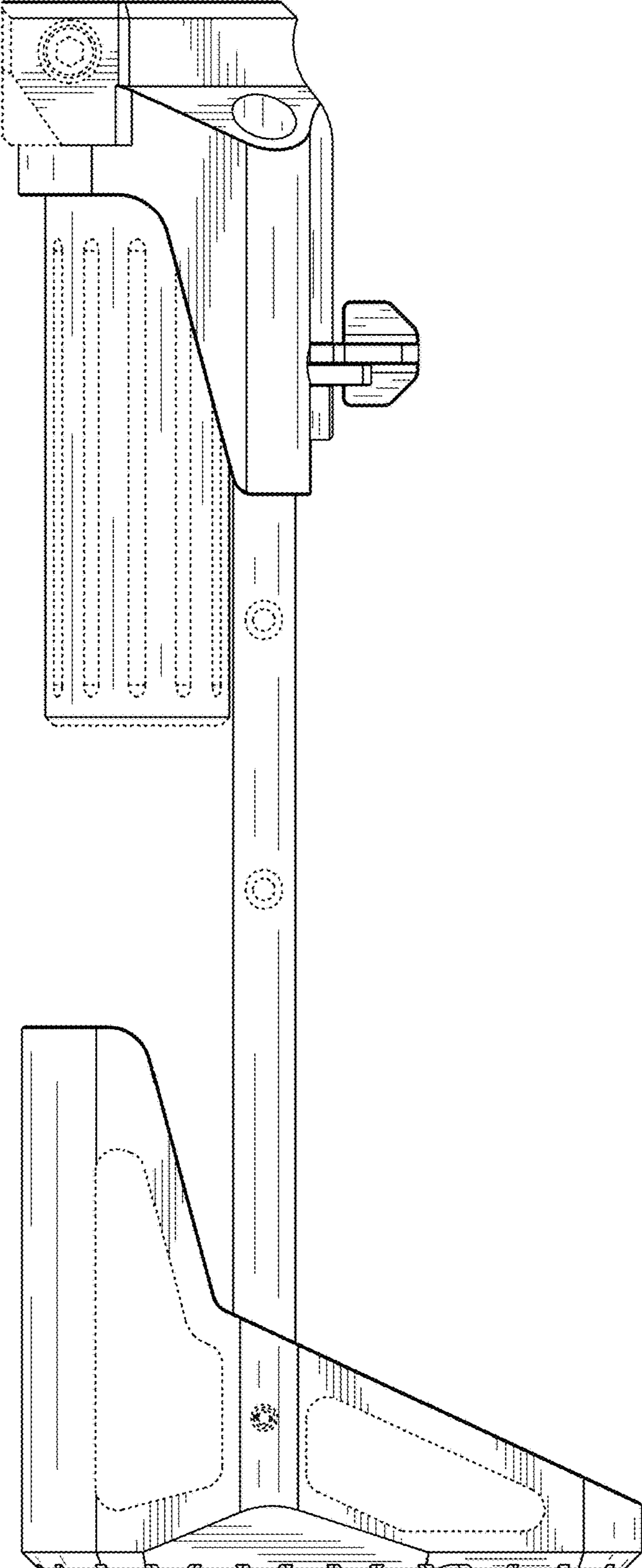

FIG. 21

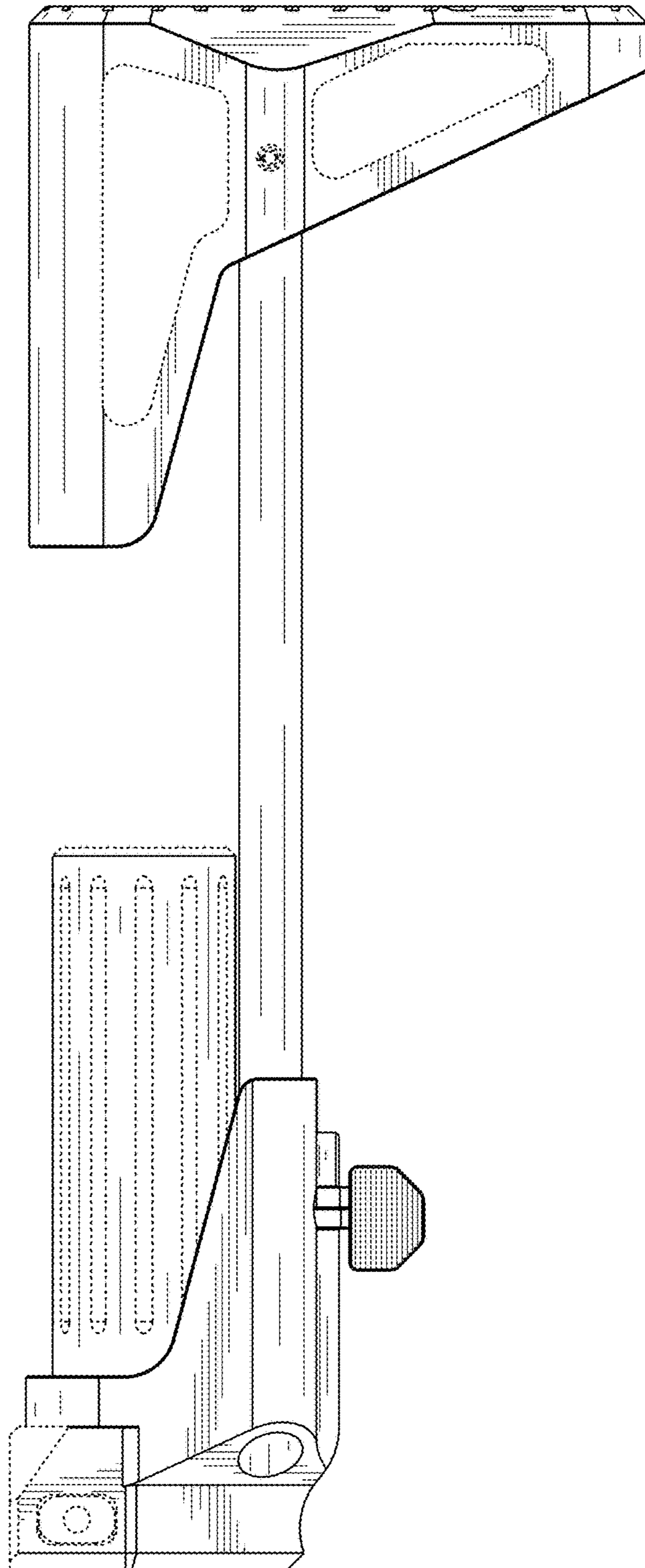

FIG. 22

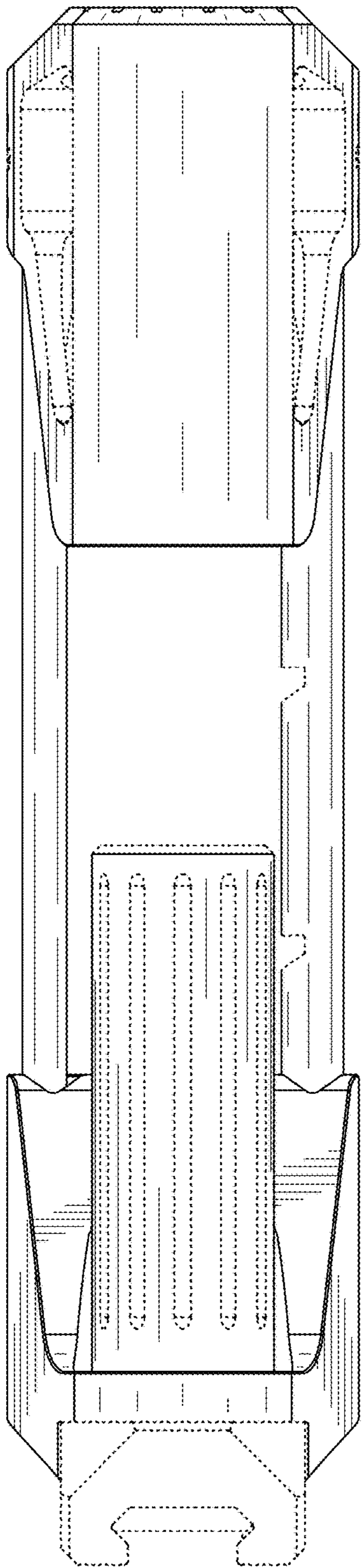

FIG. 23

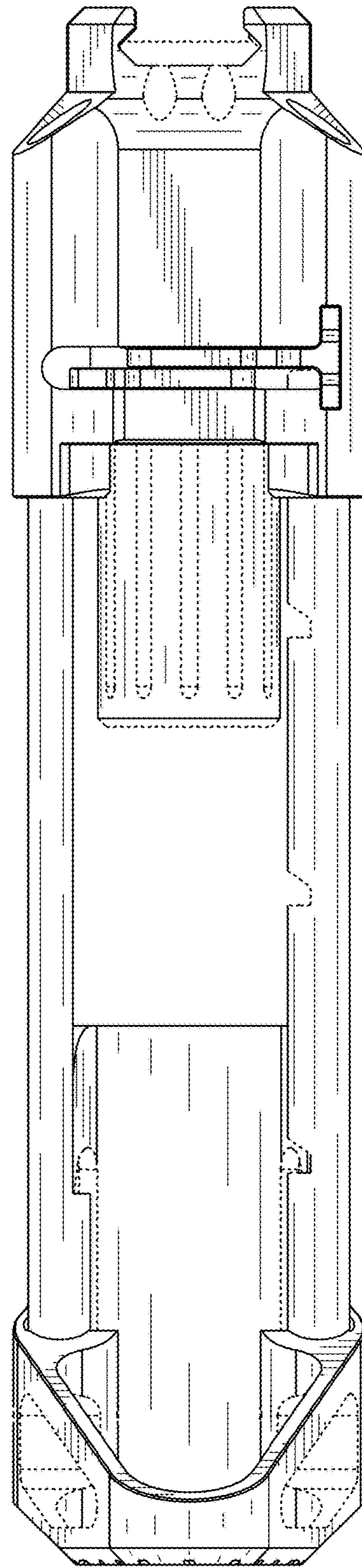

FIG. 24

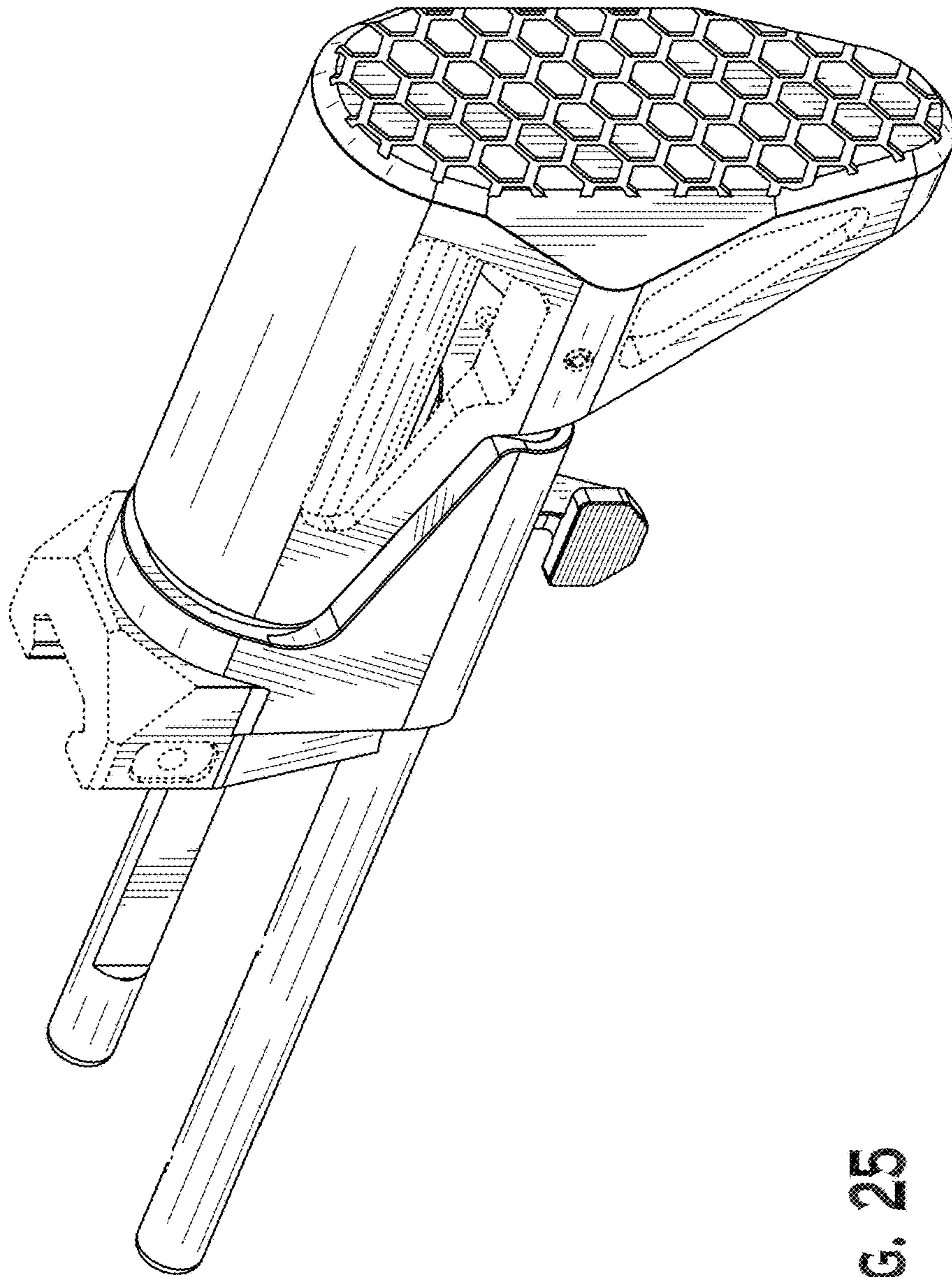

FIG. 25

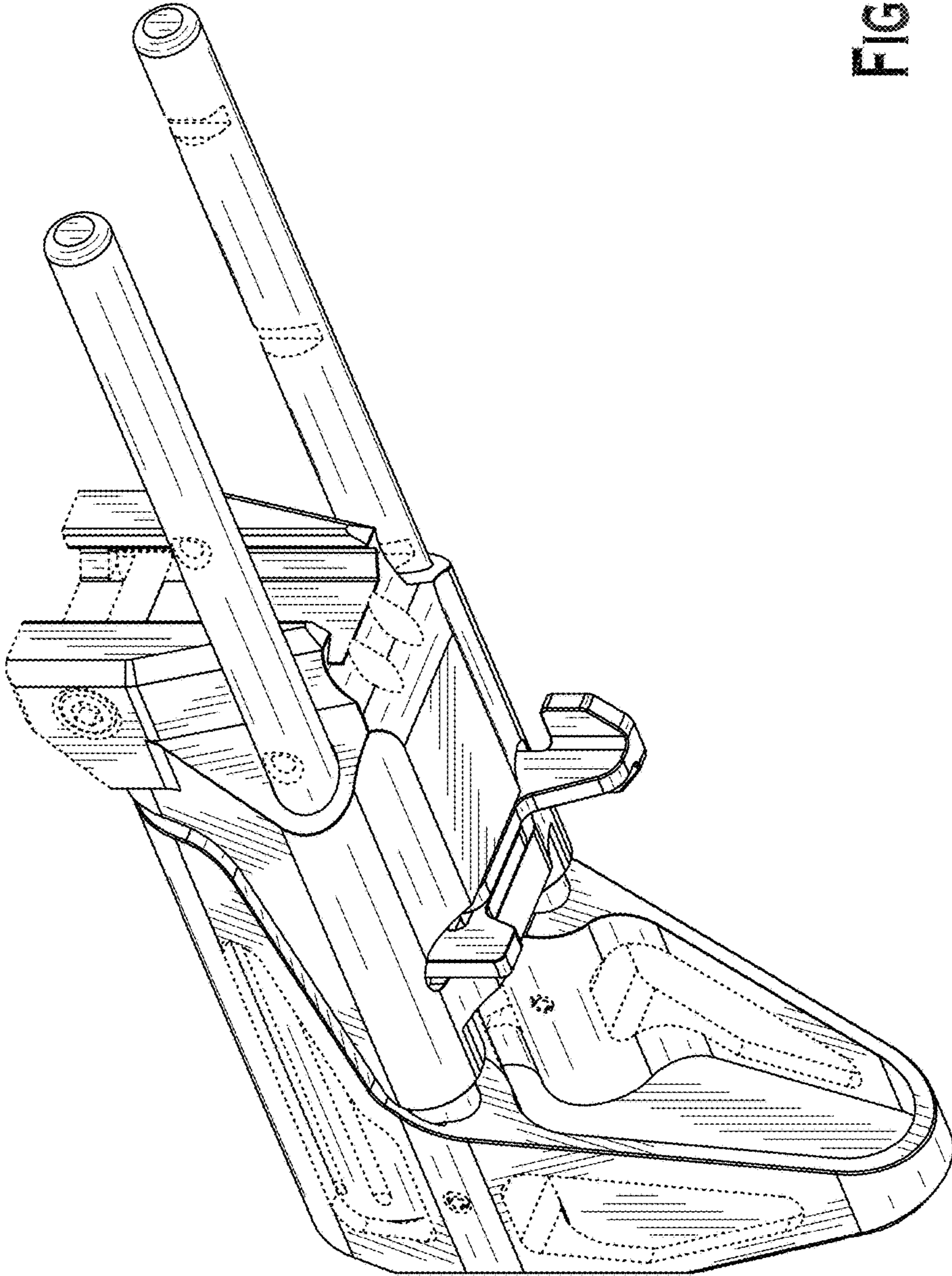

FIG. 26

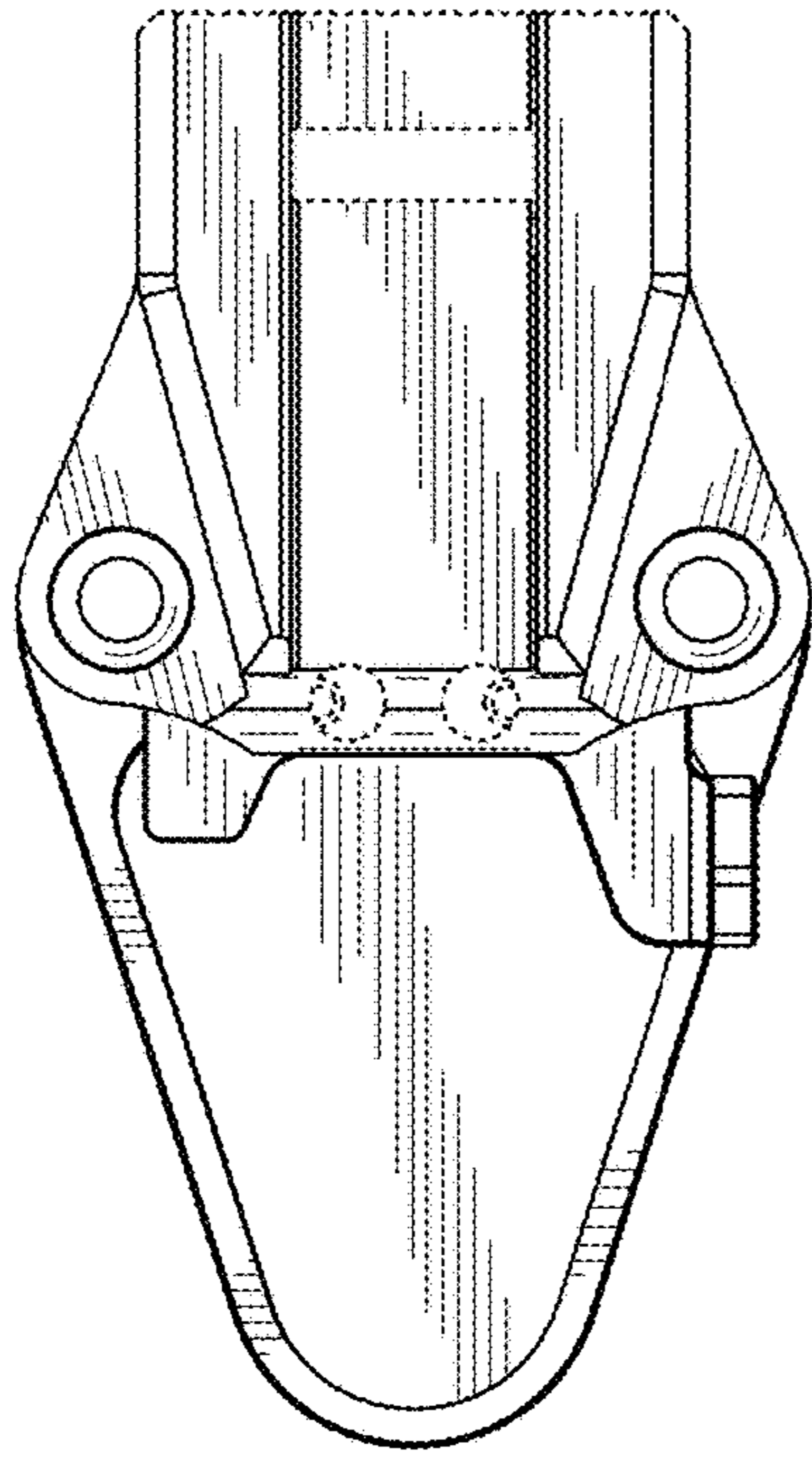

FIG. 27

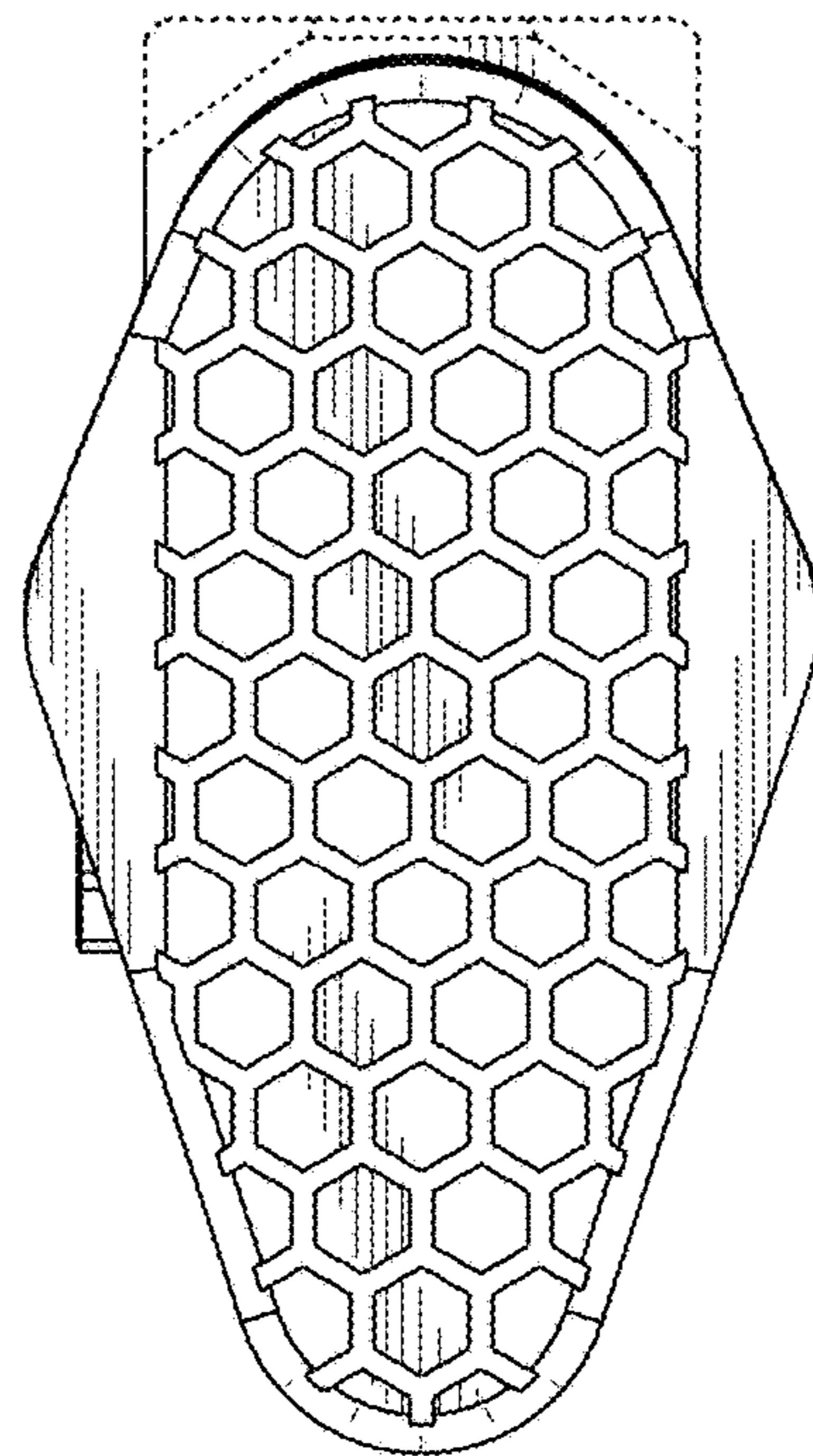

FIG. 28

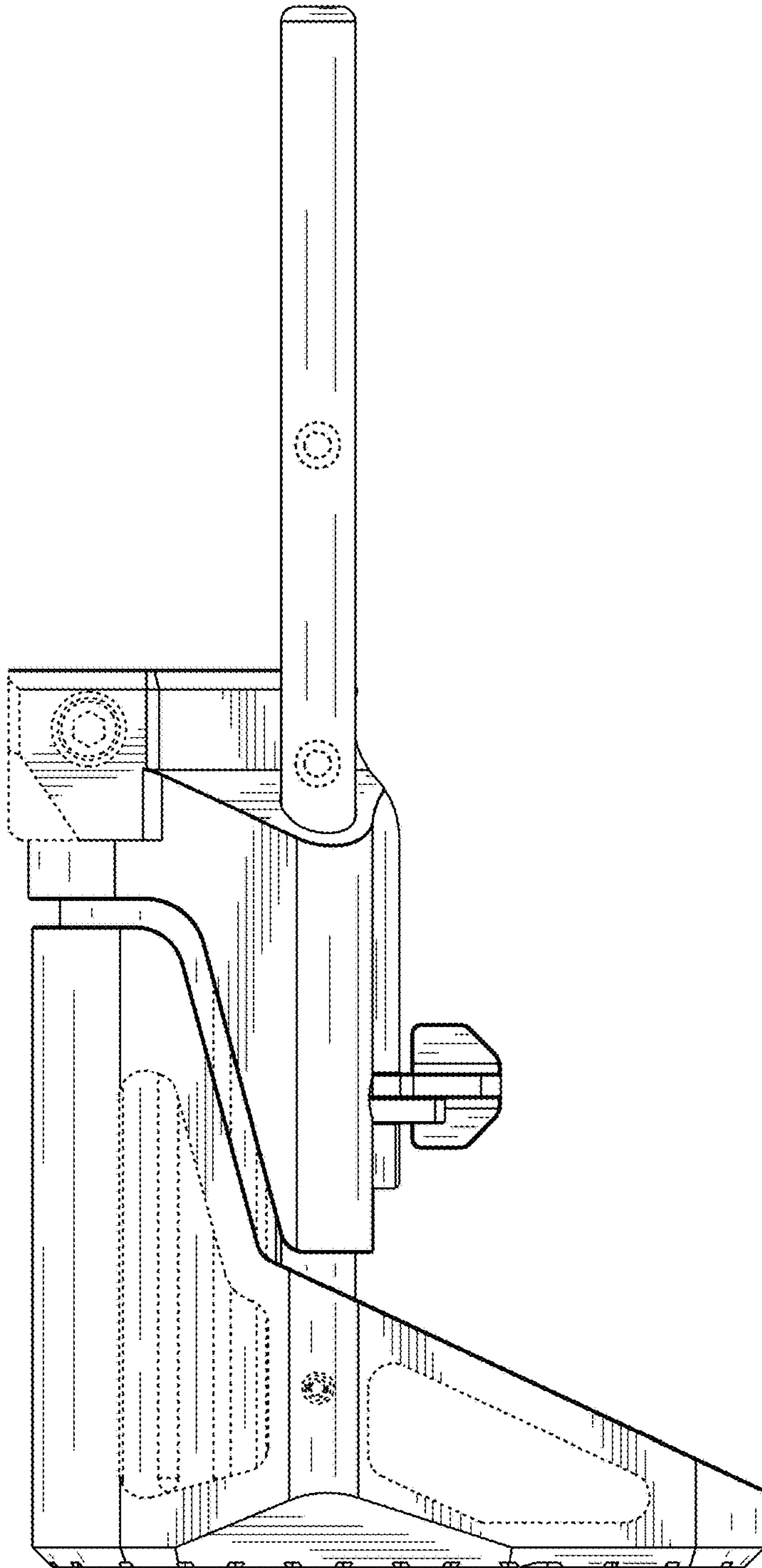

FIG. 29

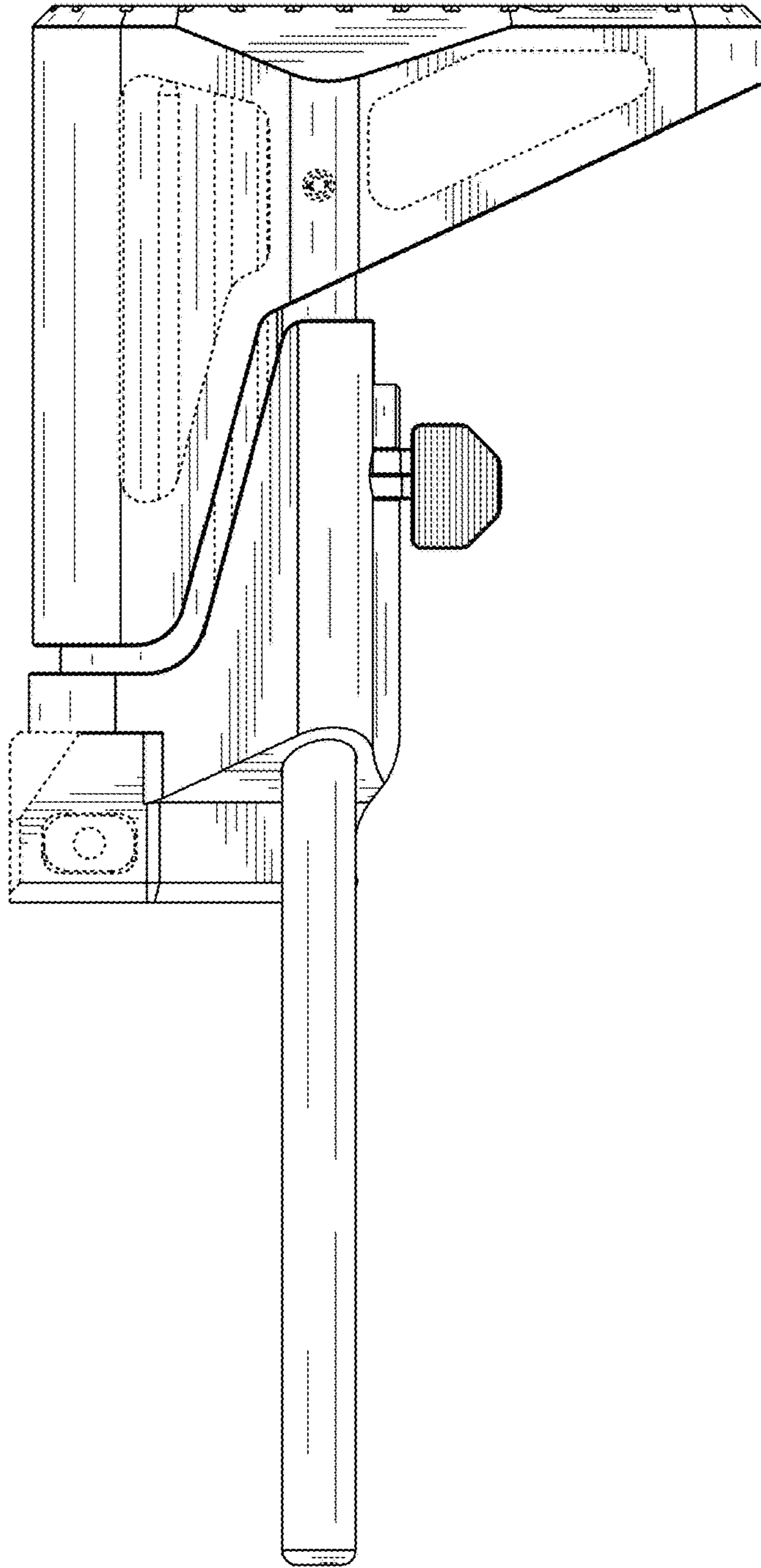

FIG. 30

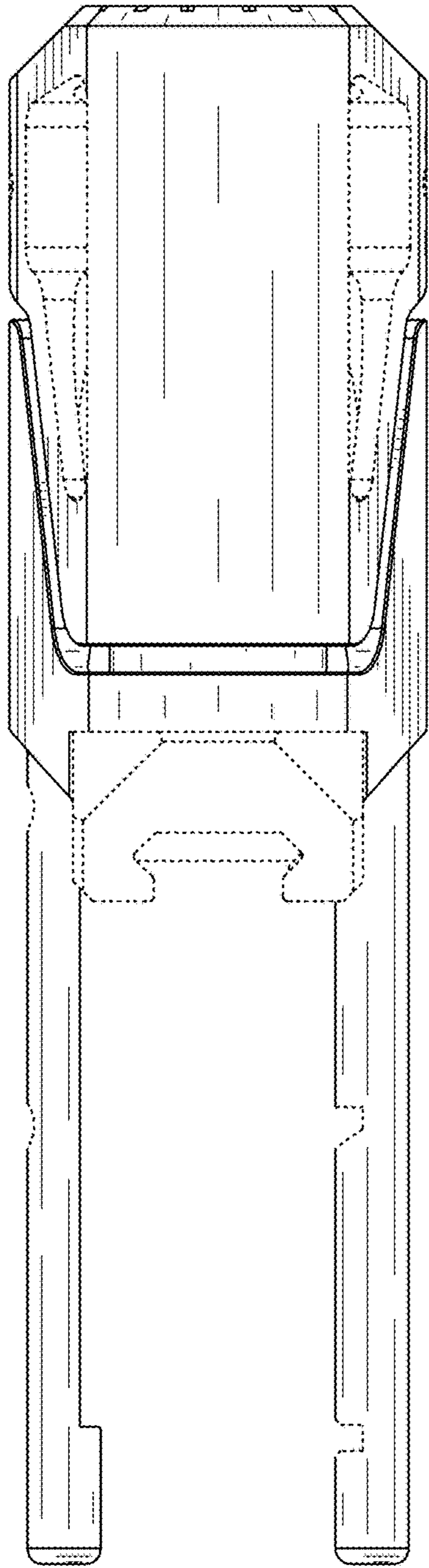

FIG. 31

FIG. 32

