



US00D847724S

(12) **United States Design Patent** (10) **Patent No.:** **US D847,724 S**
Sprowl et al. (45) **Date of Patent:** **** May 7, 2019**

(54) **ROOF FEATURE FOR A MODEL VEHICLE**

D793,328 S * 8/2017 Bridges D12/317
D803,141 S * 11/2017 Peat D12/401
D833,366 S * 11/2018 Dowdey D12/401

(71) Applicant: **TRAXXAS LP**, McKinney, TX (US)

* cited by examiner

(72) Inventors: **Jory Sprowl**, Wolfe City, TX (US);
Otto Karl Allmendinger, Rowlett, TX (US); **Casey Christen Jens Christensen**, McKinney, TX (US);
Kent Poteet, Lucas, TX (US)

Primary Examiner — Katrina A Betton

(74) *Attorney, Agent, or Firm* — Daryl R. Wright; Greg Carr

(73) Assignee: **TRAXXAS LP**, McKinney, TX (US)

(57) **CLAIM**

We claim the ornamental design for a roof feature for a model vehicle, as shown and described.

(**) Term: **15 Years**

DESCRIPTION

(21) Appl. No.: **29/633,344**

(22) Filed: **Jan. 12, 2018**

(51) **LOC (11) Cl.** **12-16**

(52) **U.S. Cl.**
USPC **D12/401**

(58) **Field of Classification Search**
USPC D12/40–405; D6/610.611, 596, 601–603,
D6/615, 617, 621; D7/332, 334–337
CPC B60J 7/19; B60J 7/0435
See application file for complete search history.

FIG. 1 is a top, right, front perspective view of a roof feature for a model vehicle;
FIG. 2 is front elevation view thereof;
FIG. 3 is a rear elevation view thereof;
FIG. 4 is a left side elevation view thereof;
FIG. 5 is a right side elevation view thereof;
FIG. 6 is a top plan view thereof;
FIG. 7 is a bottom plan view thereof;
FIG. 8 is an upper, left, rear perspective view; and,
FIG. 9 is an upper, left, front perspective environmental use view.

(56) **References Cited**

U.S. PATENT DOCUMENTS

D678,173 S * 3/2013 McIntire D12/401
D686,136 S * 7/2013 Galley D12/401
D690,256 S * 9/2013 Ewringmann D12/401
D728,450 S * 5/2015 Yen D12/401
D730,806 S * 6/2015 Lim D12/401
D776,601 S * 1/2017 McDonald, II D12/401

In the drawings, the broken line showing of features of the roof feature for a model vehicle illustrate portions of the roof feature for a model vehicle that form no part of the claimed design; whereas, the broken line showing of the environmental use view depicts environmental subject matter and is provided for the purposes of illustrating environmental use structure and context.

1 Claim, 7 Drawing Sheets

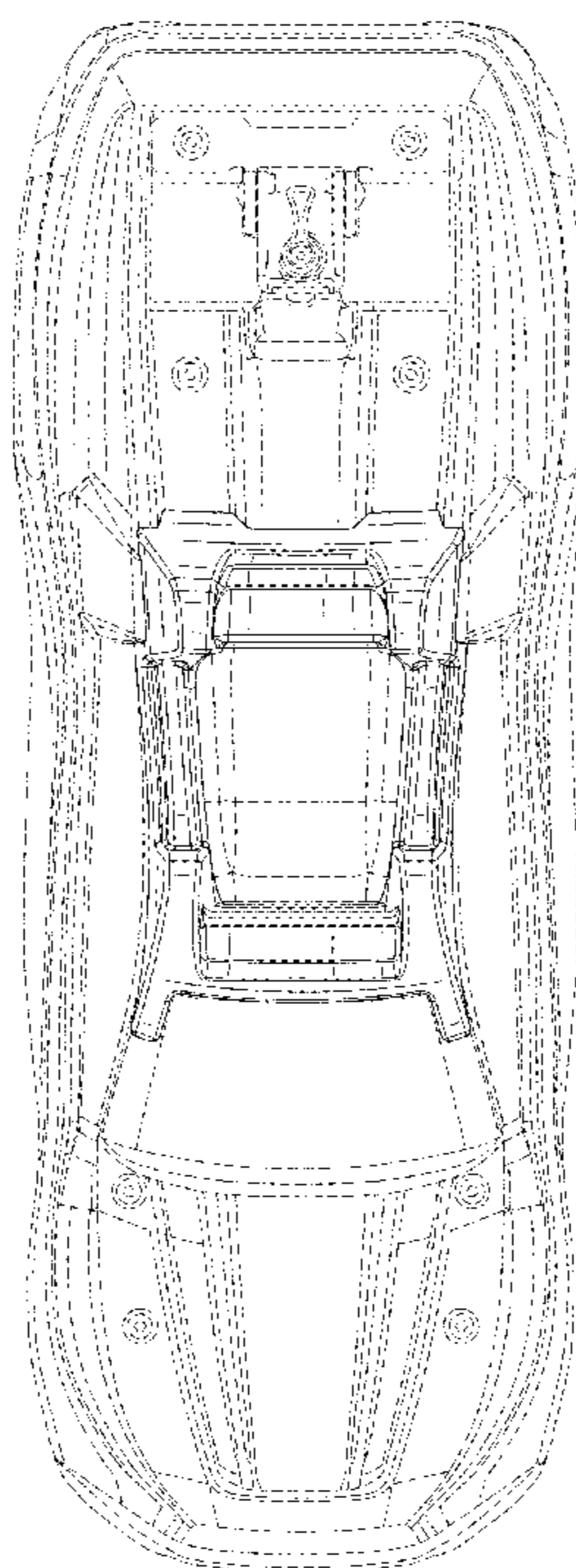

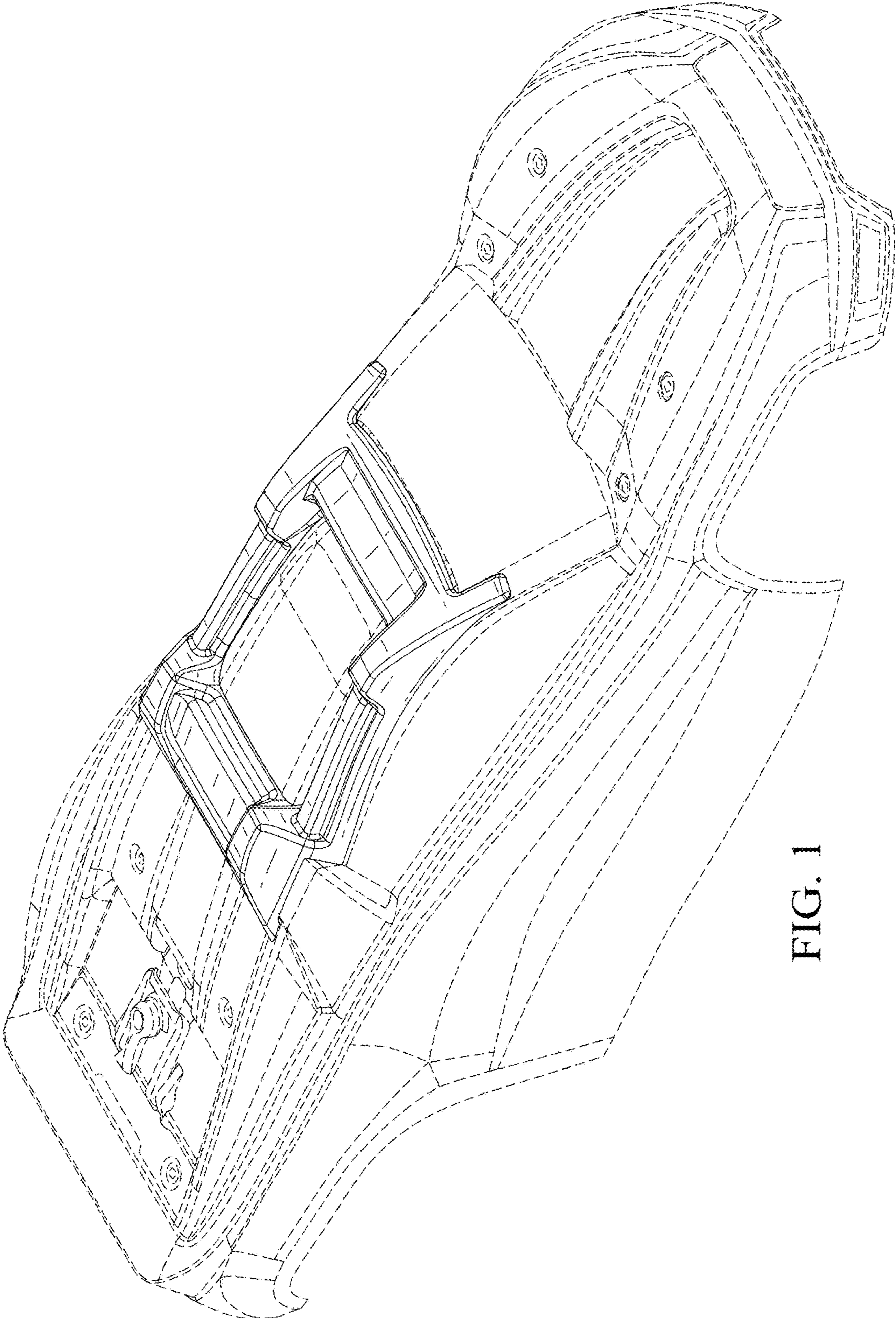

FIG. 1

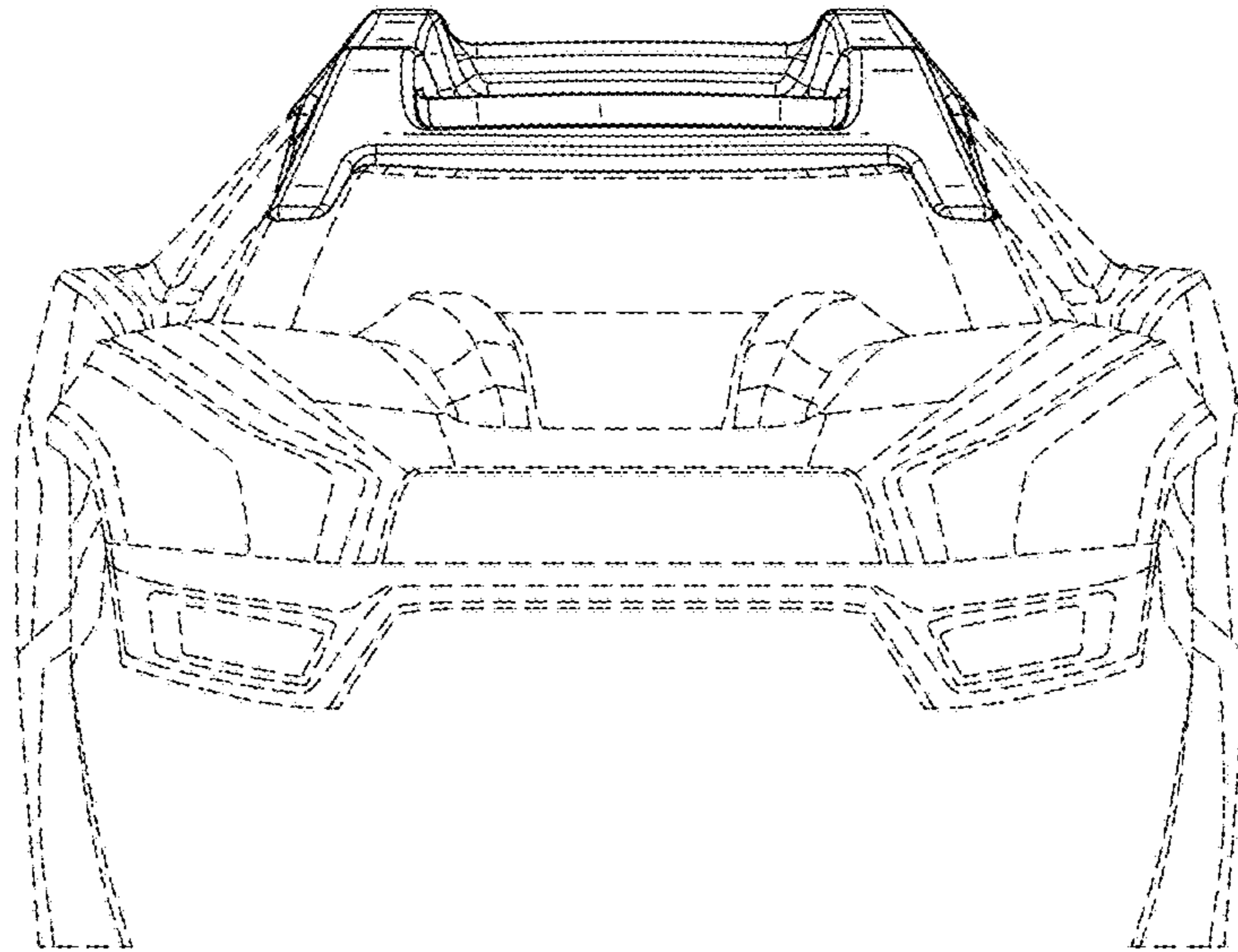

FIG. 2

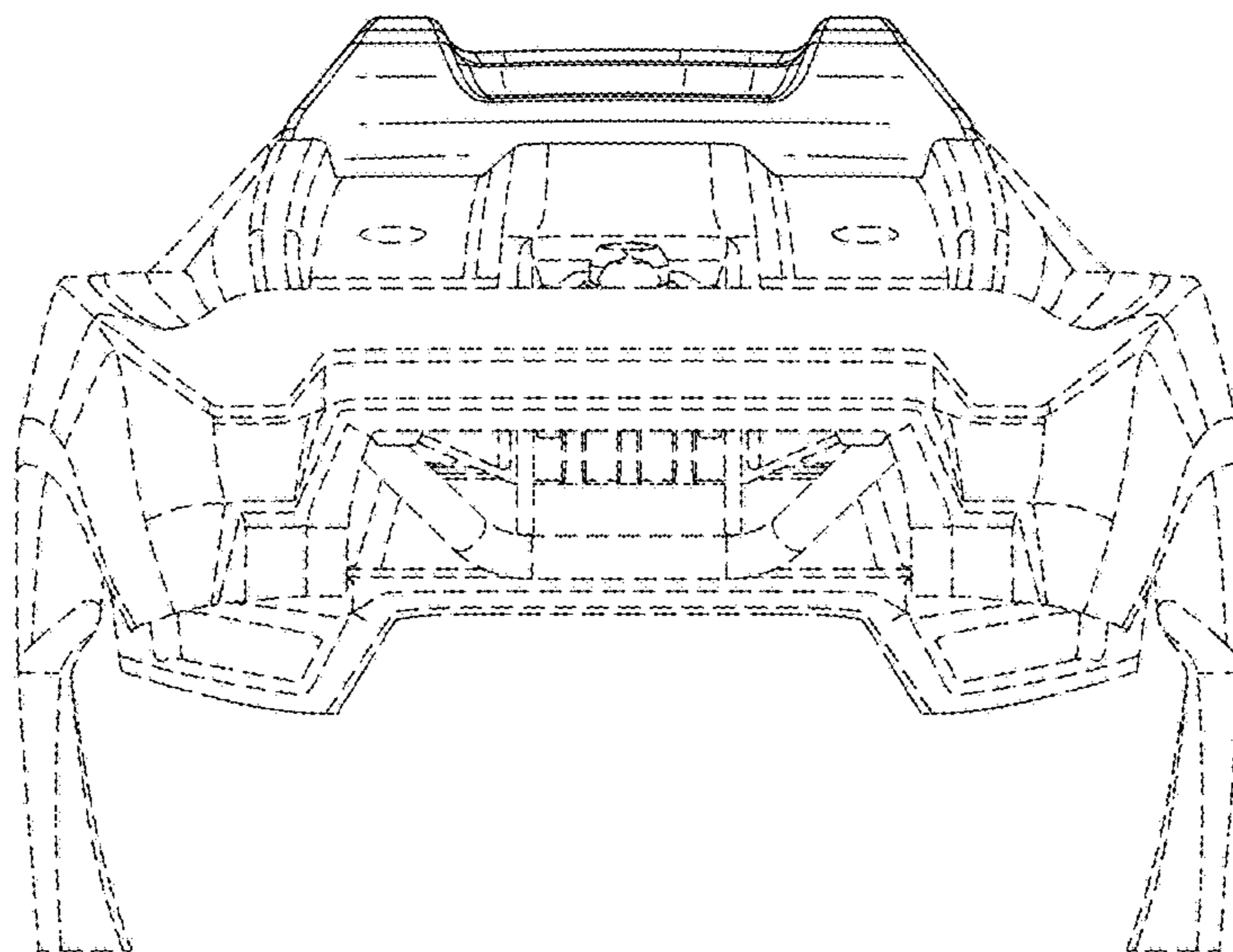

FIG. 3

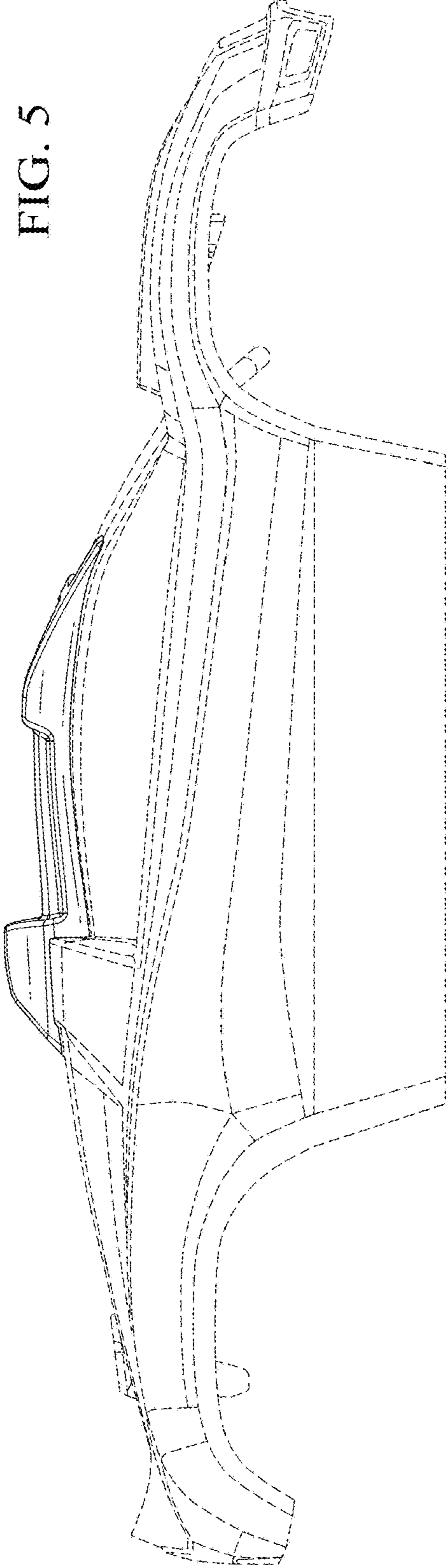
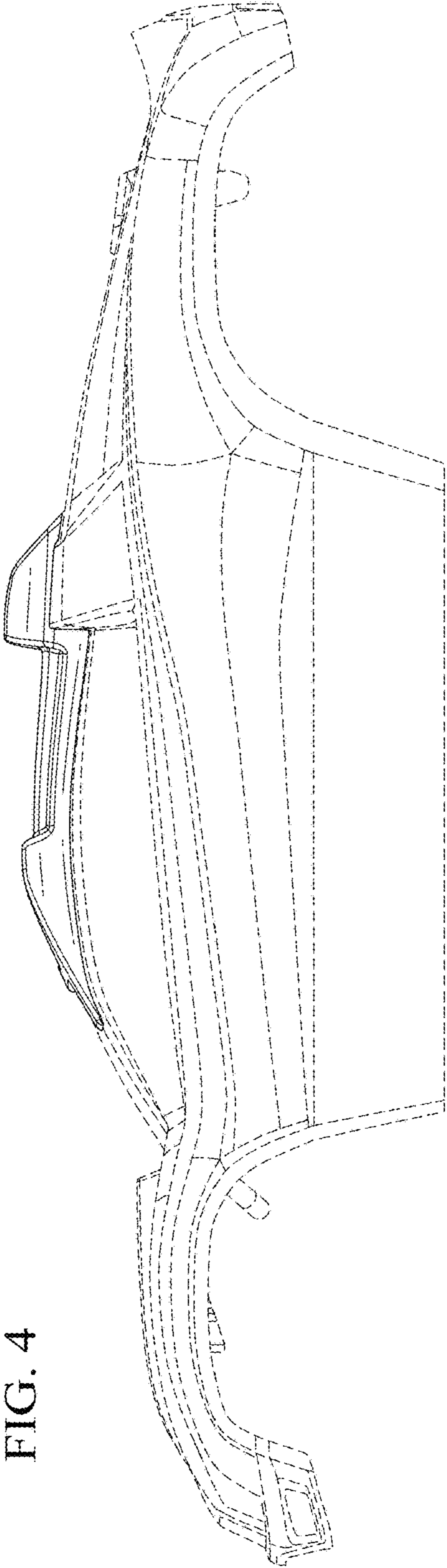

FIG. 4

FIG. 5

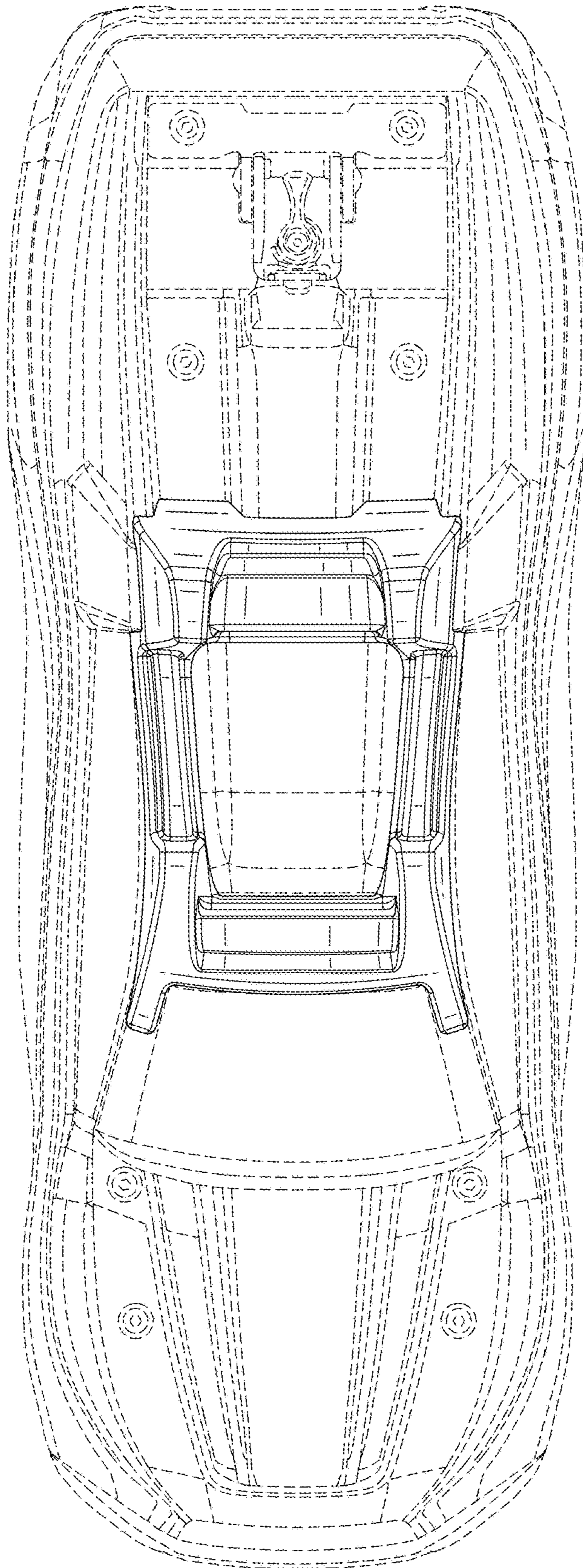

FIG. 6

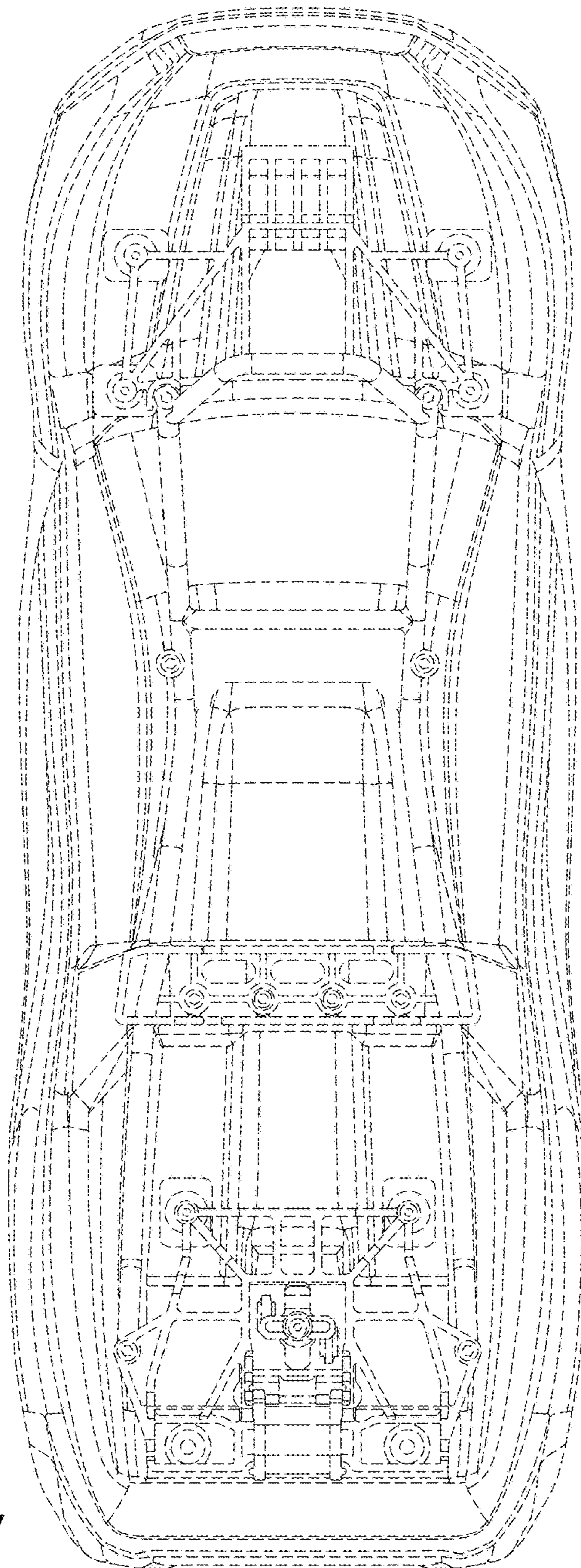

FIG. 7

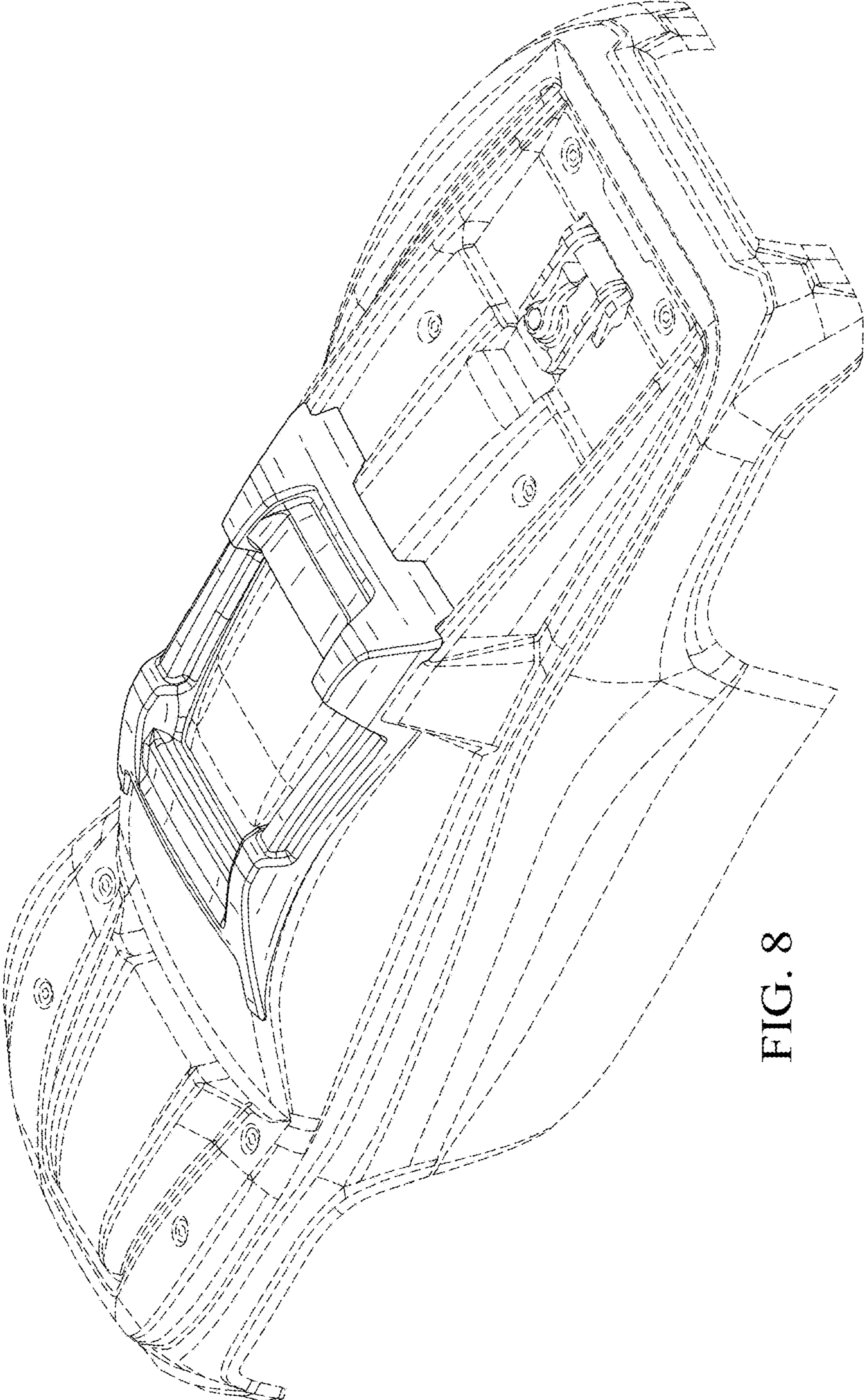

FIG. 8

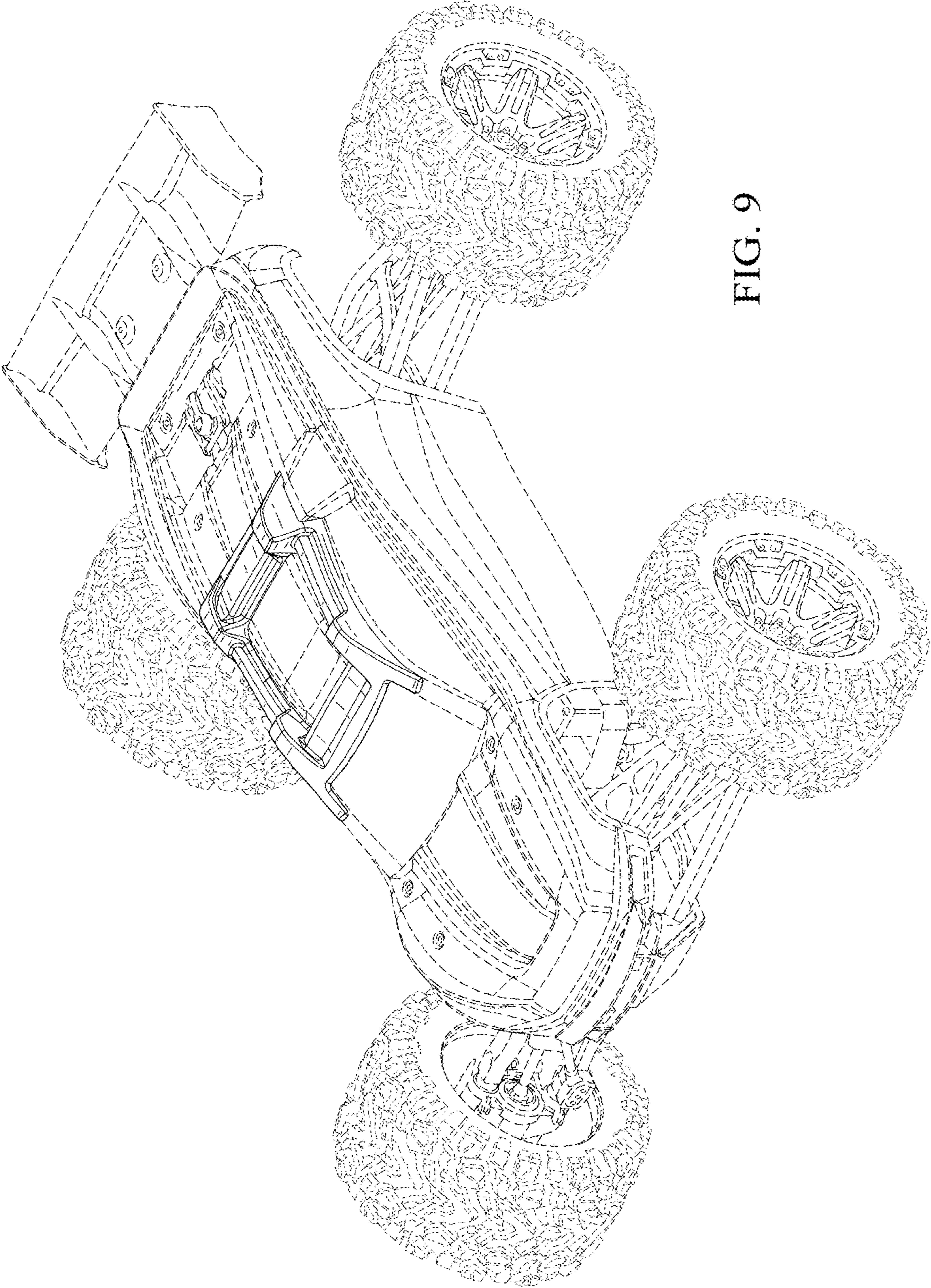

FIG. 9