

US00D847710S

(12) **United States Design Patent**
Canepa et al.

(10) **Patent No.:** **US D847,710 S**

(45) **Date of Patent:** **** May 7, 2019**

(54) **HANDLEBAR FOR CYCLES OR MOTORCYCLES**

(71) Applicant: **PIAGGIO & C S.p.A.**, Pontedera (Pisa) (IT)

(72) Inventors: **Marco Canepa**, Pontedera (IT); **Marco Lambri**, Pontedera (IT)

(73) Assignee: **PIAGGIO & C. S.P.A.**, Pontedera (Pisa) (IT)

(**) Term: **15 Years**

(21) Appl. No.: **29/602,662**

(22) Filed: **May 2, 2017**

(30) **Foreign Application Priority Data**

Nov. 4, 2016 (EM) 003447937

(51) **LOC (11) Cl.** **12-11**

(52) **U.S. Cl.**
USPC **D12/178**

(58) **Field of Classification Search**
USPC D12/111, 114, 178; D8/303
CPC B62K 19/16; B62K 21/12; B62K 21/18;
B62K 21/125; B62K 23/06
See application file for complete search history.

(56) **References Cited**

U.S. PATENT DOCUMENTS

6,249,744 B1 * 6/2001 Morita B62J 99/00
340/988
D450,278 S * 11/2001 Solberg D12/178

D519,911 S * 5/2006 Mah D12/317
D637,545 S * 5/2011 Cote D12/317
D654,411 S * 2/2012 Alt D12/178
D691,527 S * 10/2013 Thorpe D12/178
D719,894 S * 12/2014 Akita D12/307
D738,276 S * 9/2015 Arbour D12/178
D817,237 S * 5/2018 Talios D12/178

* cited by examiner

Primary Examiner — Darlington Ly

(74) *Attorney, Agent, or Firm* — Cantor Colburn LLP

(57) **CLAIM**

The ornamental design for a handlebar for cycles or motorcycles, as shown and described.

DESCRIPTION

FIG. 1 is a top, rear, and right side perspective view of a handlebar for cycles or motorcycles showing our new design;

FIG. 2 is a front elevation view thereof;

FIG. 3 is a rear elevation view thereof;

FIG. 4 is a left side elevation view thereof;

FIG. 5 is a right side elevation view thereof;

FIG. 6 is a top plan view thereof; and,

FIG. 7 is a bottom plan view thereof.

The broken lines in the drawings illustrate portions of the handlebar for cycles or motorcycles that form no part of the claimed design.

1 Claim, 7 Drawing Sheets

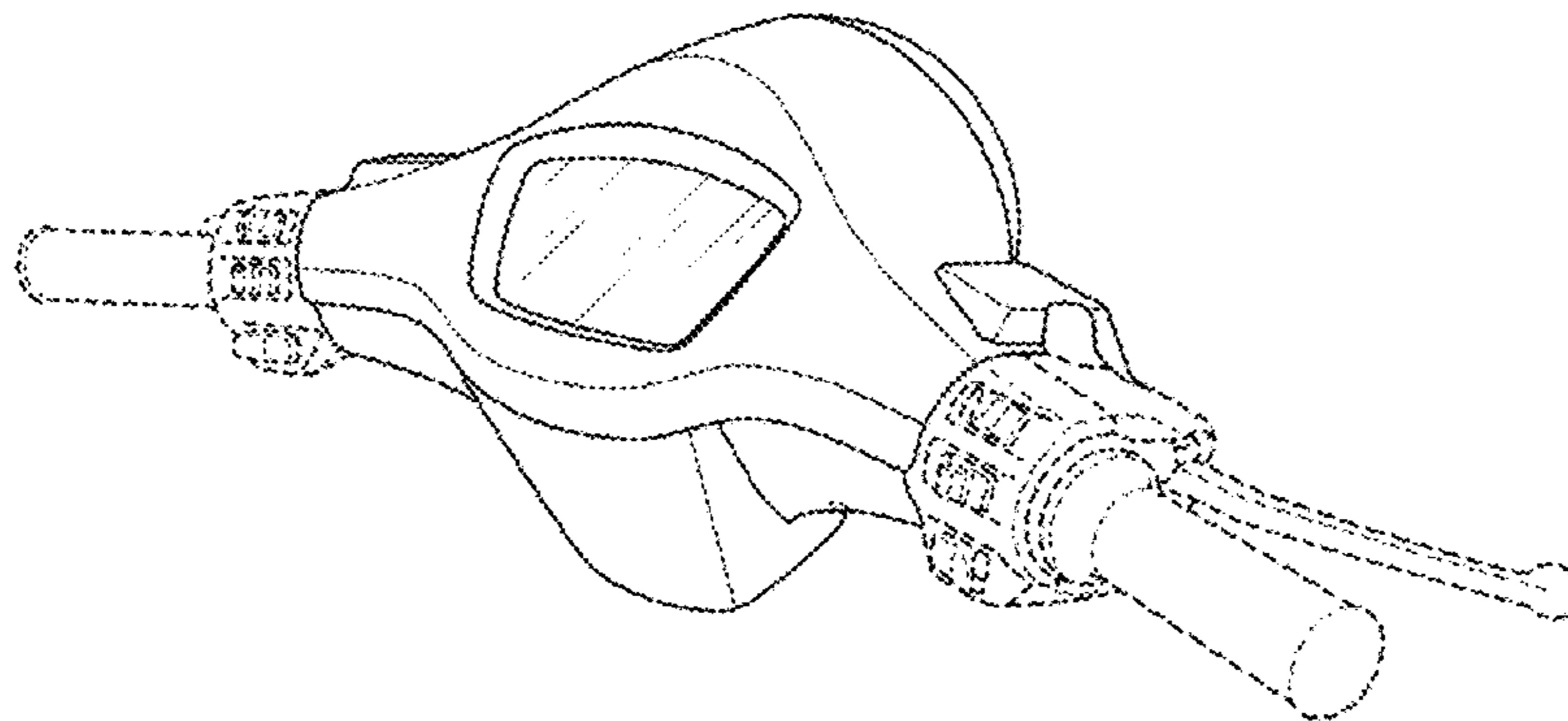

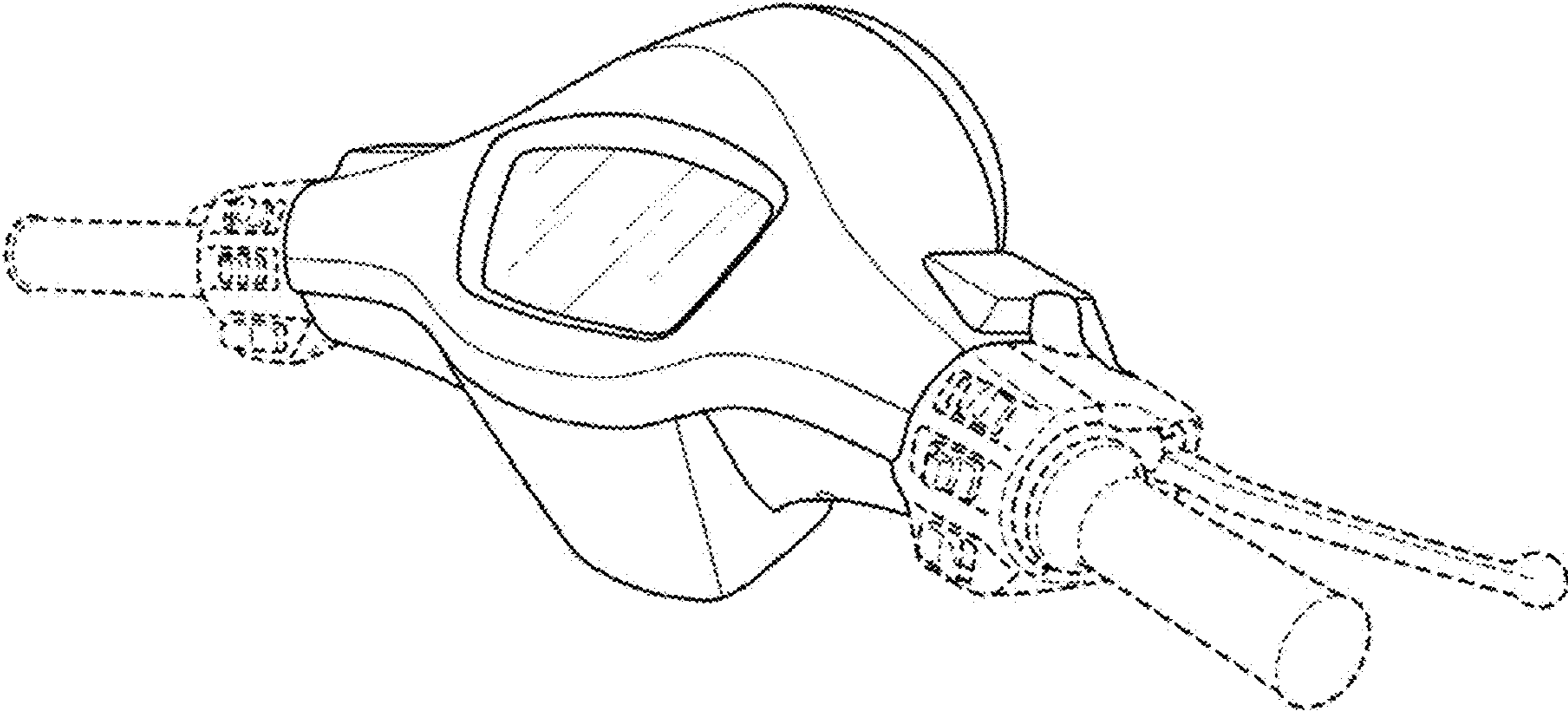

FIG. 1

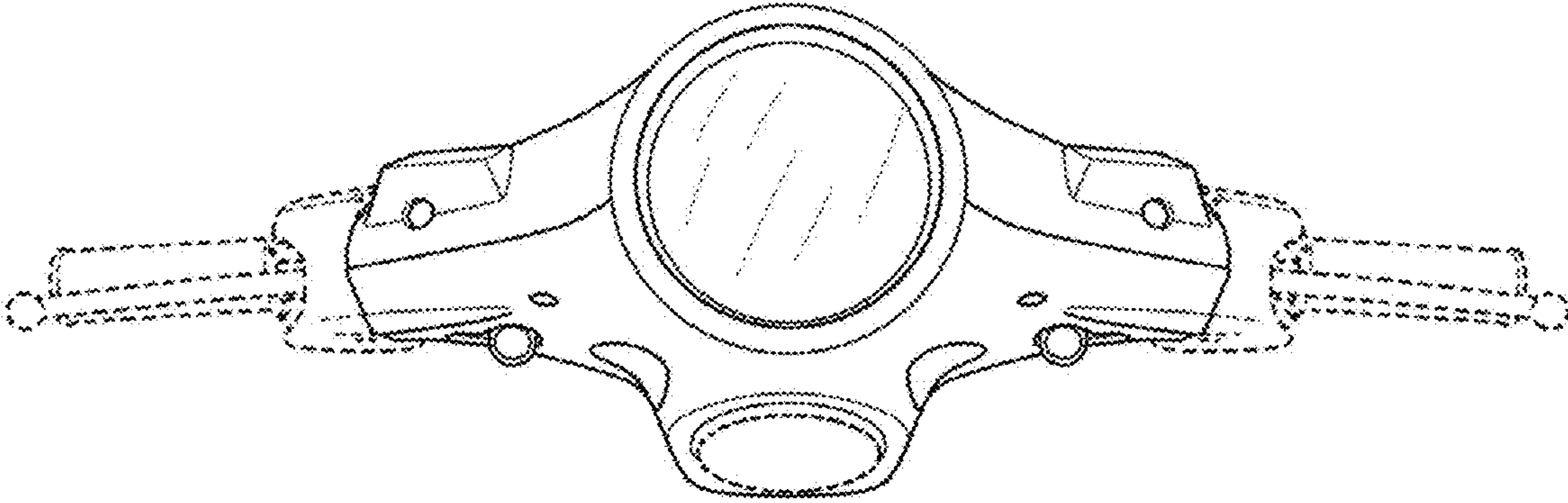

FIG. 2

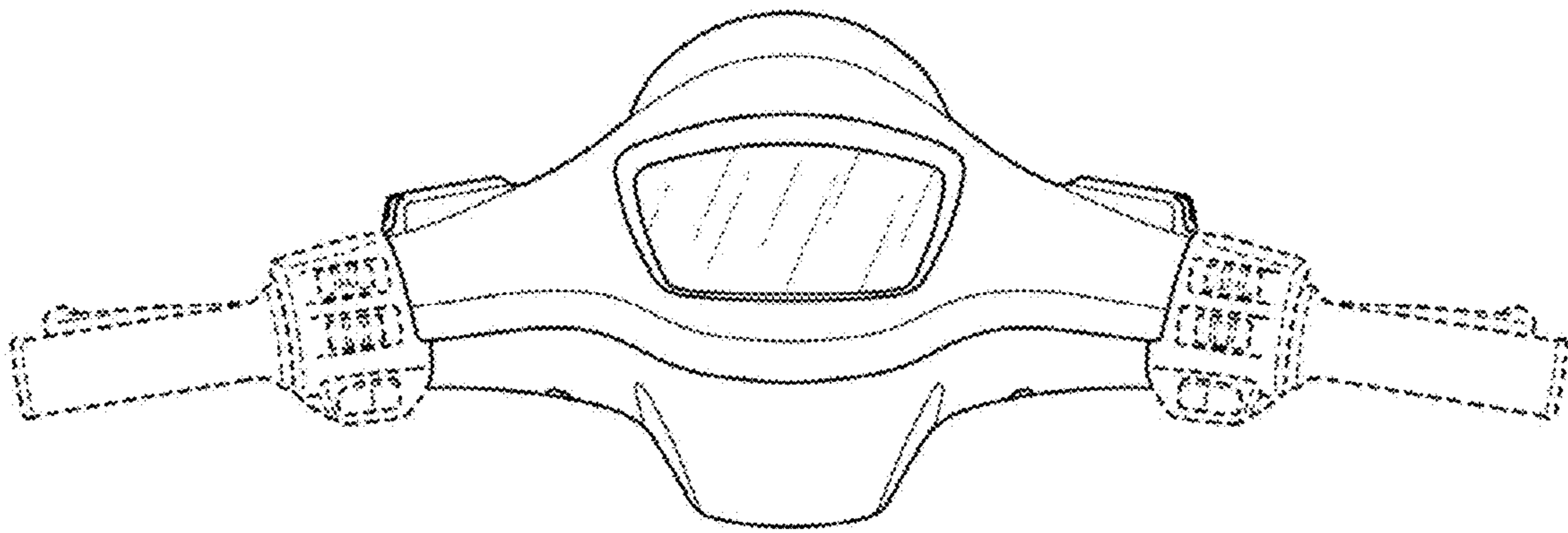

FIG. 3

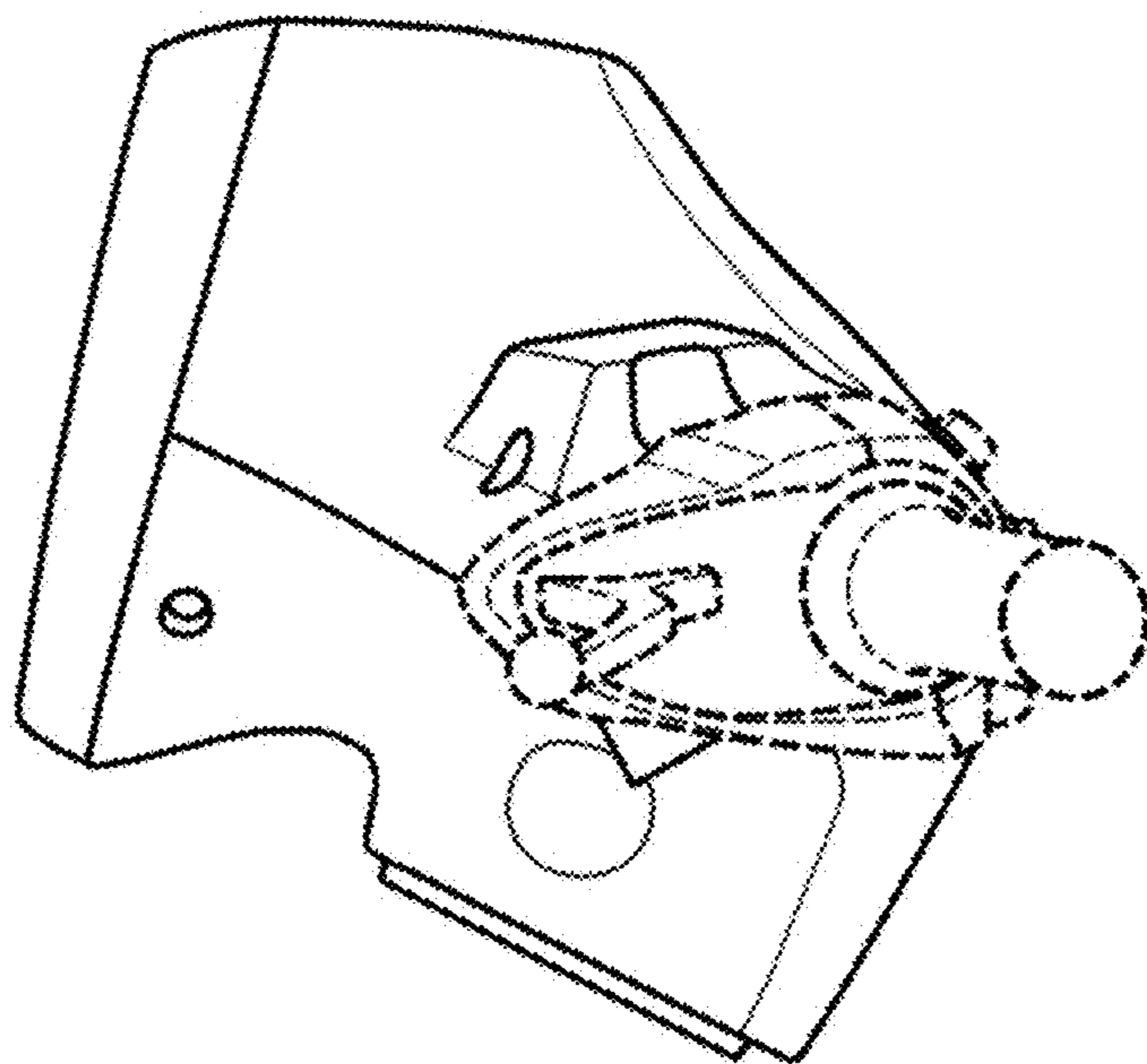

FIG. 4

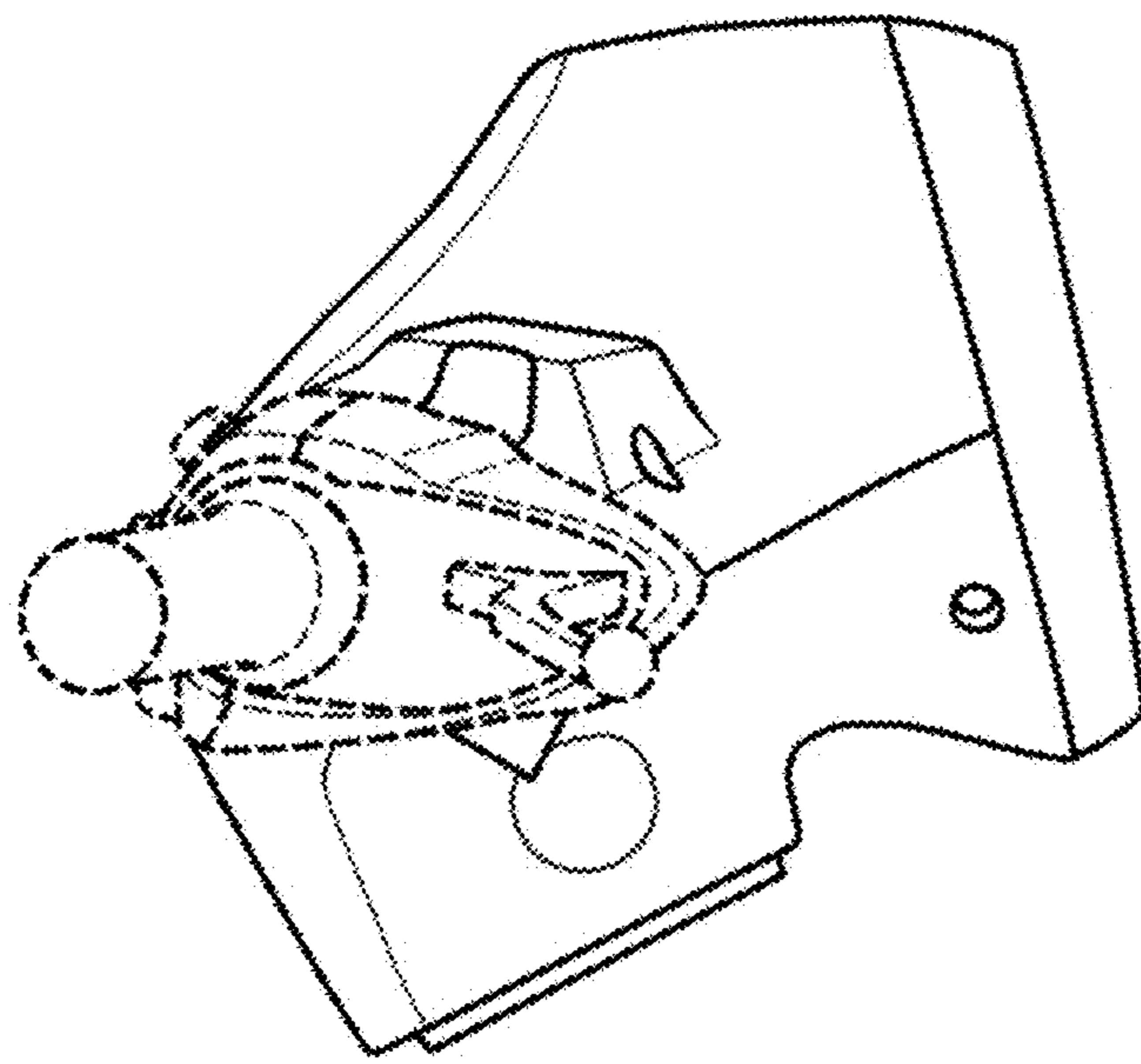

FIG. 5

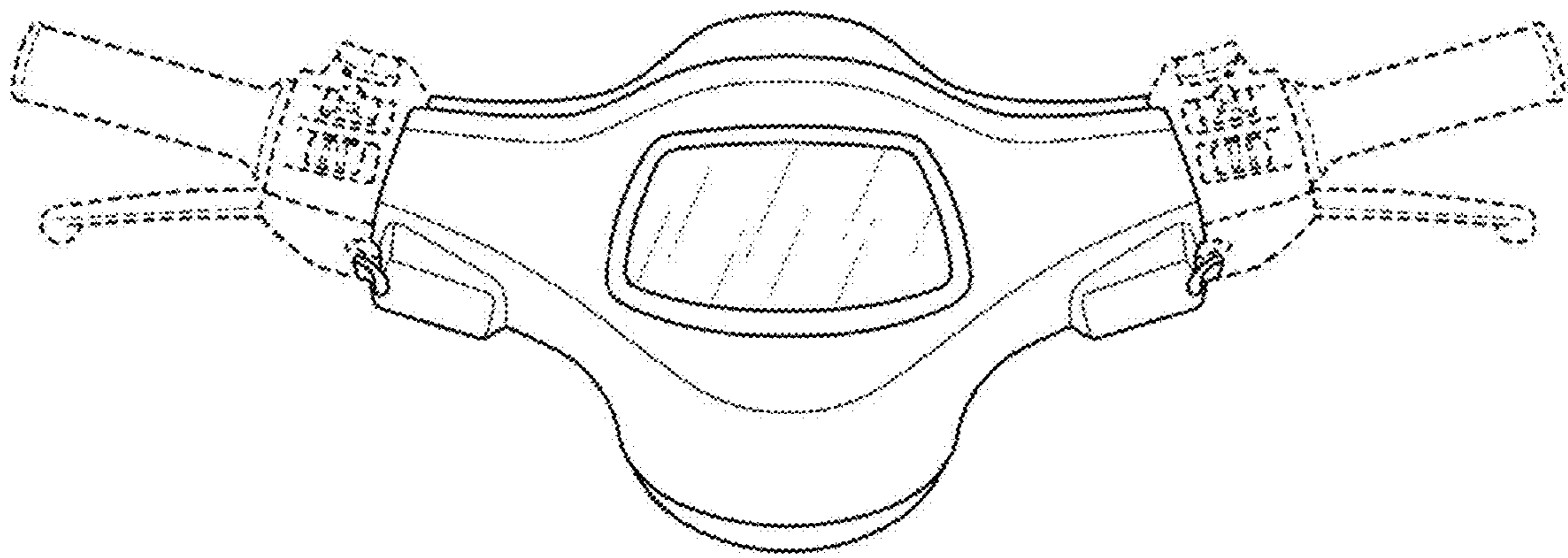

FIG. 6

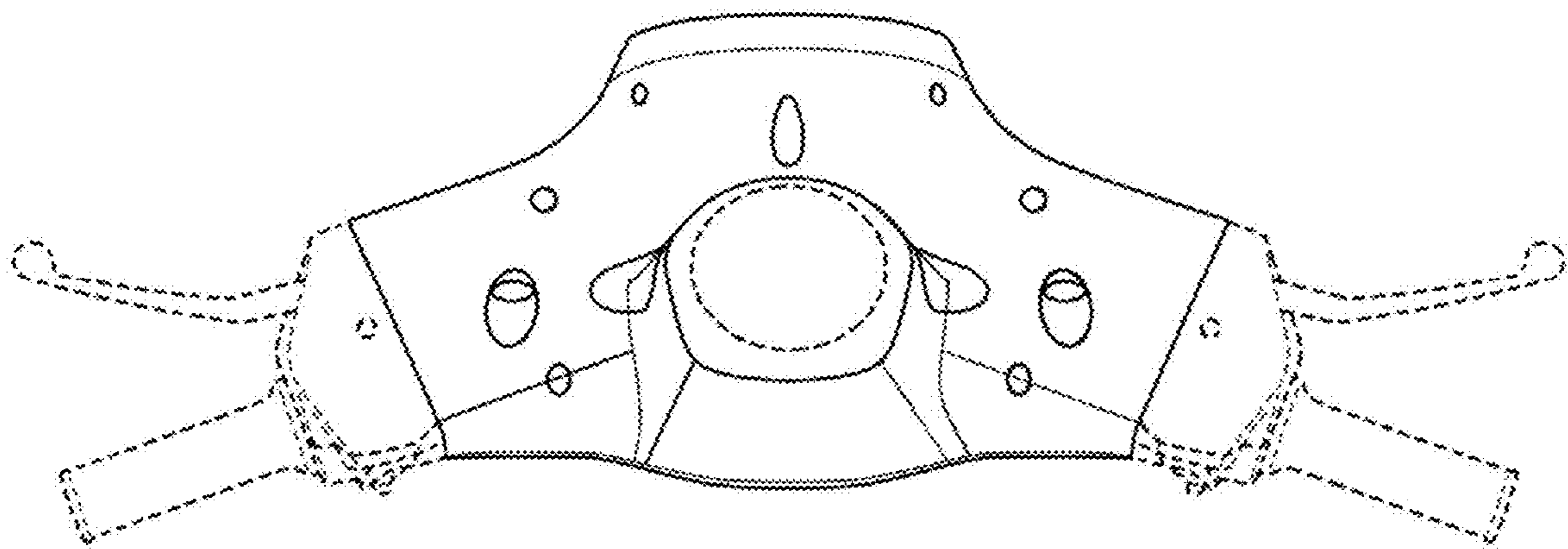

FIG. 7