



US00D847500S

(12) **United States Design Patent**
Lagerfeld

(10) **Patent No.:** **US D847,500 S**

(45) **Date of Patent:** **** May 7, 2019**

(54) **BAG**

(71) Applicant: **Chanel, Inc.**, New York, NY (US)

(72) Inventor: **Karl Lagerfeld**, Paris (FR)

(73) Assignee: **Chanel, Inc.**, New York, NY (US)

(**) Term: **15 Years**

(21) Appl. No.: **29/601,155**

(22) Filed: **Apr. 19, 2017**

(51) **LOC (11) Cl.** **03-01**

(52) **U.S. Cl.**
USPC **D3/245**

(58) **Field of Classification Search**
USPC D3/232-233, 240-246
CPC A45C 1/024; A45C 3/06
See application file for complete search history.

(56) **References Cited**

U.S. PATENT DOCUMENTS

D684,361 S *	6/2013	Chiozzi	D3/245
D773,812 S *	12/2016	Slimane	D3/244
D782,818 S *	4/2017	Slimane	D3/244
D794,951 S *	8/2017	Gavriel	D3/244
D804,171 S *	12/2017	Judah	D3/245

* cited by examiner

Primary Examiner — Holly H Baynham

(74) *Attorney, Agent, or Firm* — Fross Zelnick Lehrman & Zissu, P.C.

(57) **CLAIM**

The ornamental design for bag, as shown and described.

DESCRIPTION

FIG. 1 is a front perspective view of the bag shown in FIG. 1, without quilting, and with the chain design as shown in FIGS. 113-123;

FIG. 2 is a front view thereof;

FIG. 3 is a back view thereof;

FIG. 4 is a left side view thereof;

FIG. 5 is a right side view thereof;

FIG. 6 is a top view thereof;

FIG. 7 is a bottom view thereof;

FIG. 8 is an alternative embodiment of the bag shown in FIG. 8;

FIG. 9 is a front view thereof;

FIG. 10 is a back view thereof;

FIG. 11 is a left side view thereof;

FIG. 12 is a right side view thereof;

FIG. 13 is a top view thereof;

FIG. 14 is a bottom view thereof;

FIG. 15 is another alternative embodiment of the bag shown in FIG. 8;

FIG. 16 is a front view thereof;

FIG. 17 is a back view thereof;

FIG. 18 is a left side view thereof;

FIG. 19 is a right side view thereof;

FIG. 20 is a top view thereof; and,

FIG. 21 is a bottom view thereof.

The broken line showing portions of the handbag designs, the environment of a person, and portions of the chain and handles in the drawings shows unclaimed subject matter.

The broken lines other than those showing portions of the handbag designs, the environment of a person, and portions of the chain and handles, are understood to represent stitching.

1 Claim, 15 Drawing Sheets

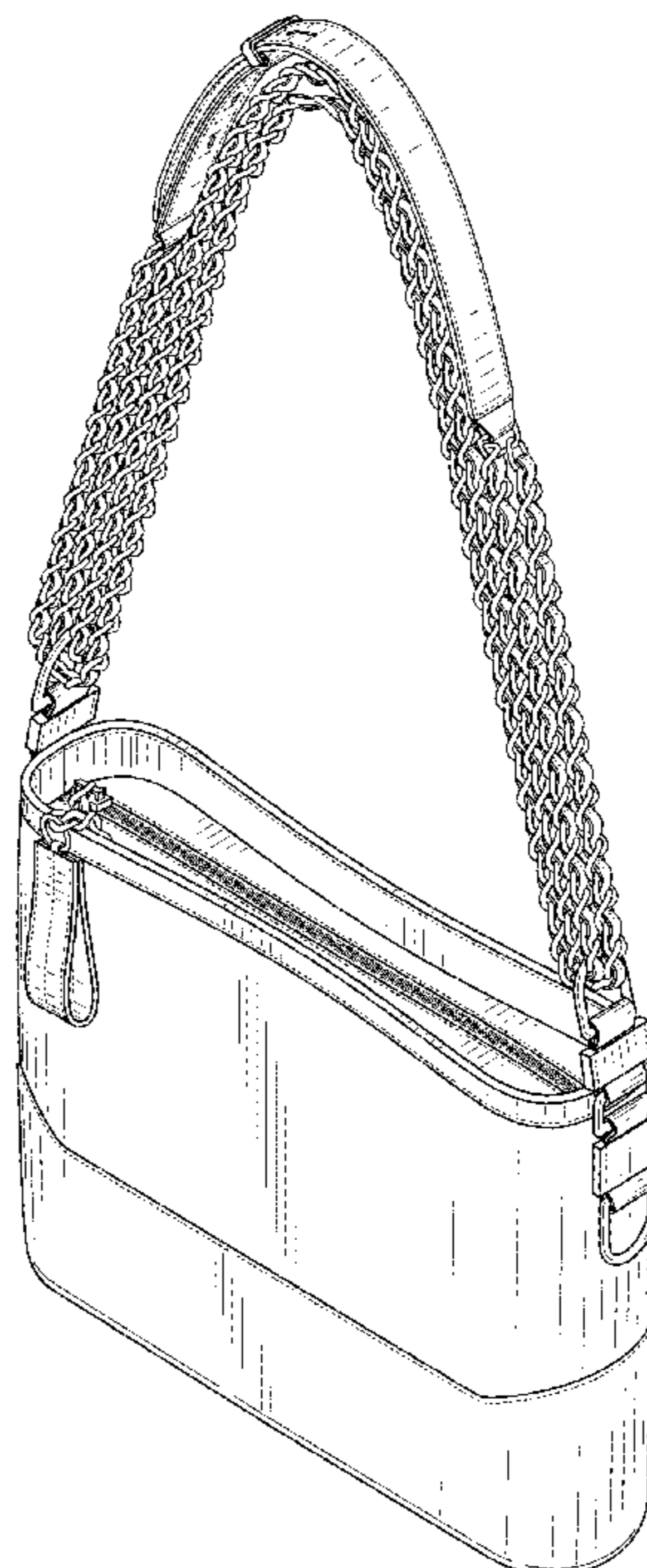

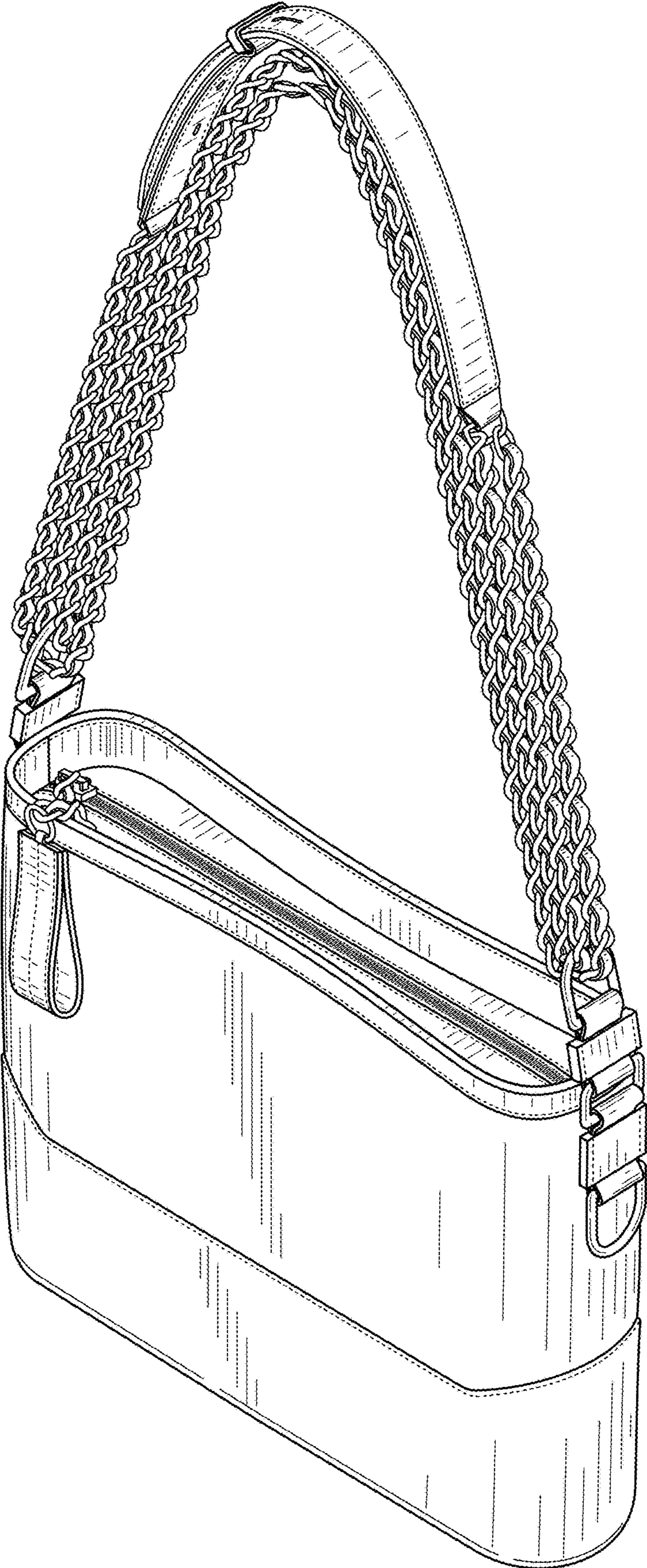

FIG. 1

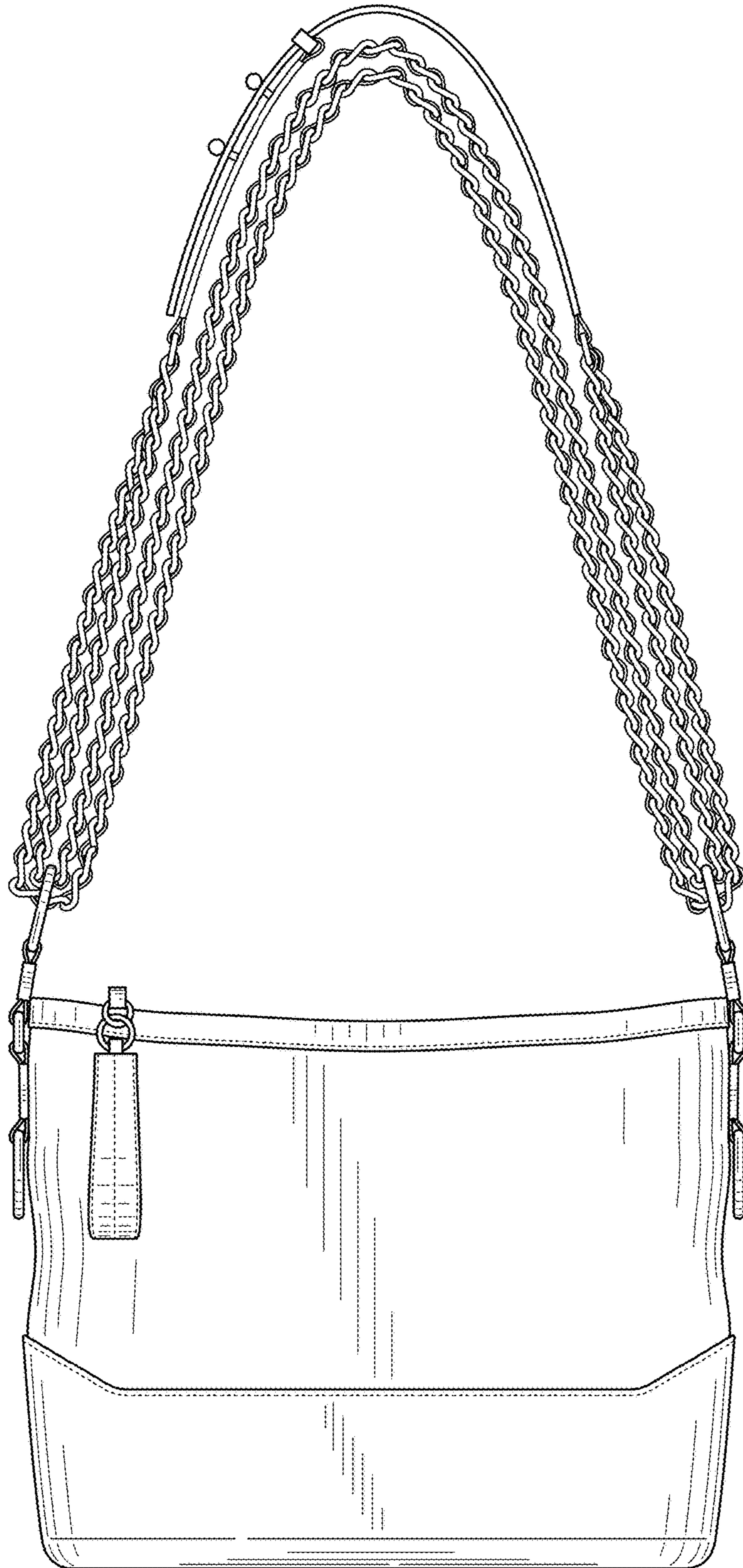

FIG. 2

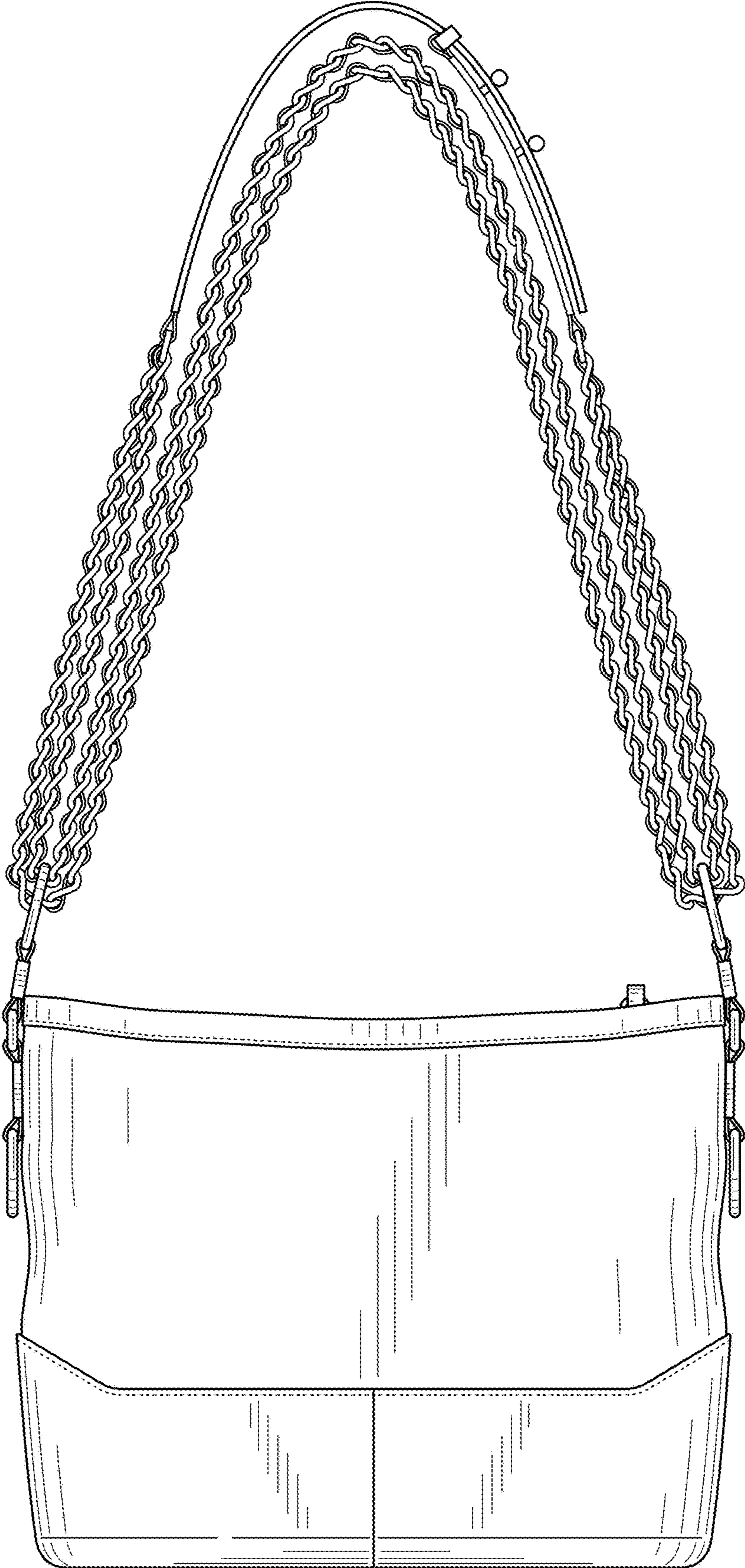

FIG. 3

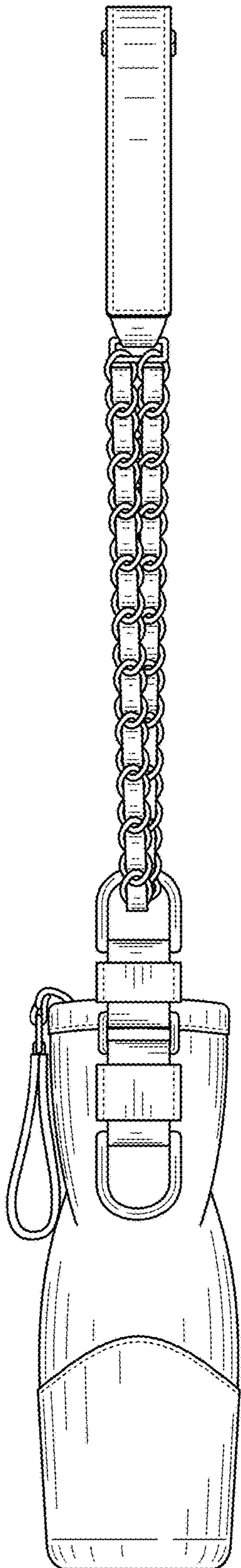

FIG. 4

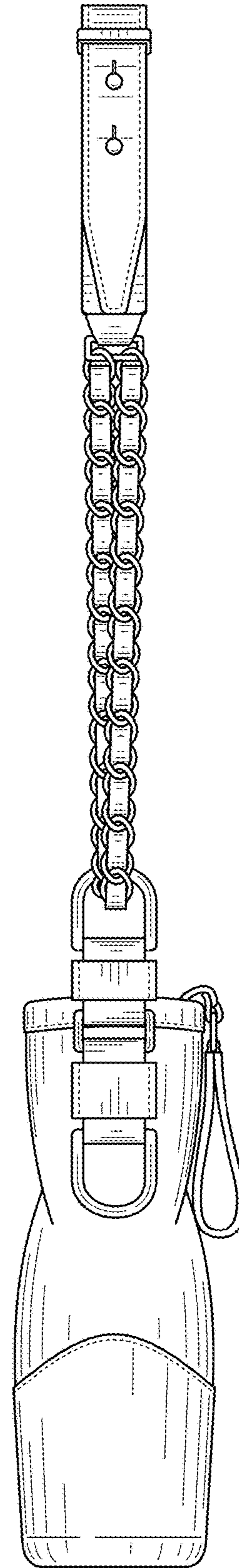

FIG. 5

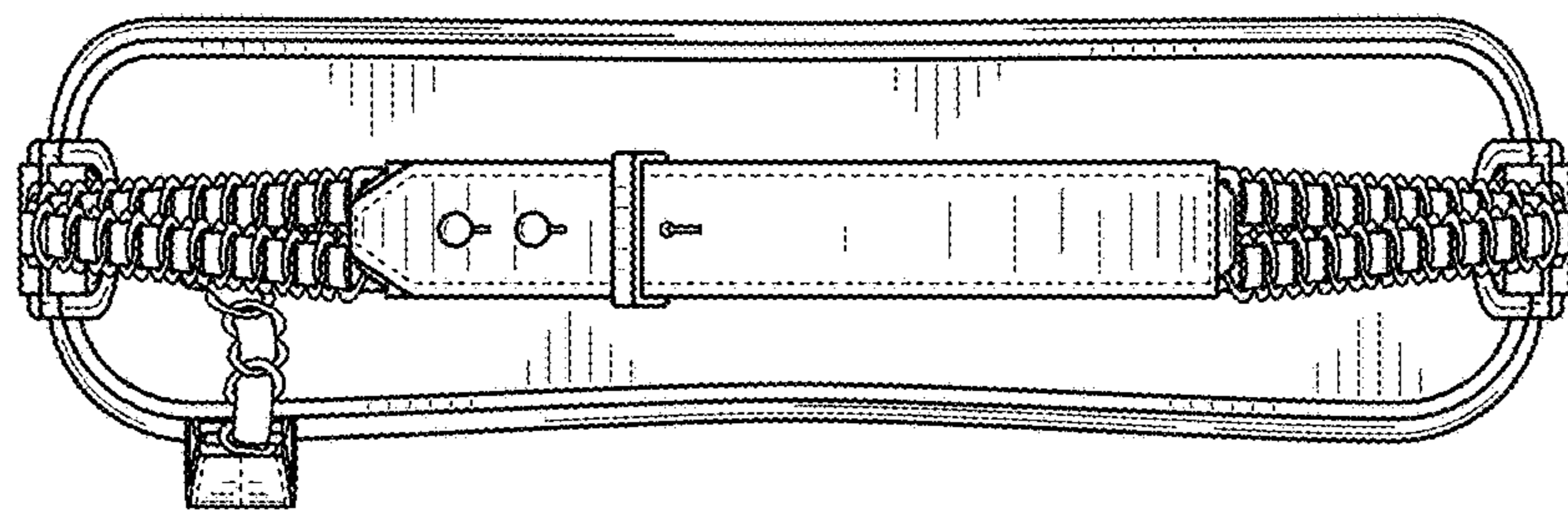

FIG. 6

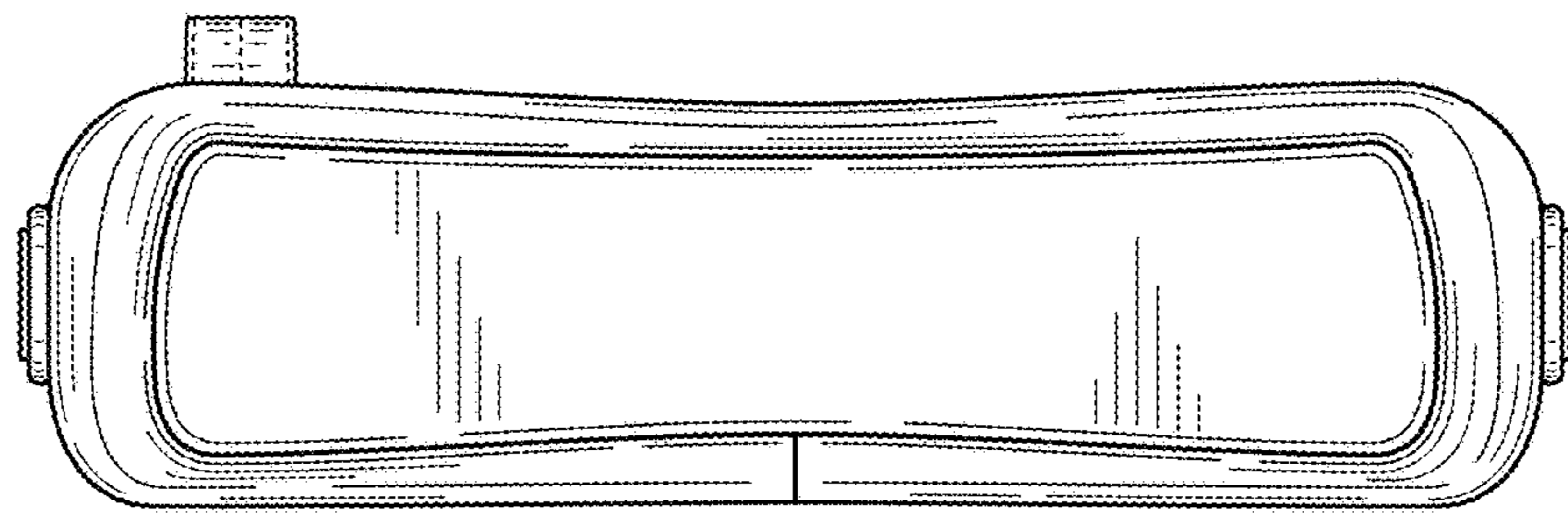

FIG. 7

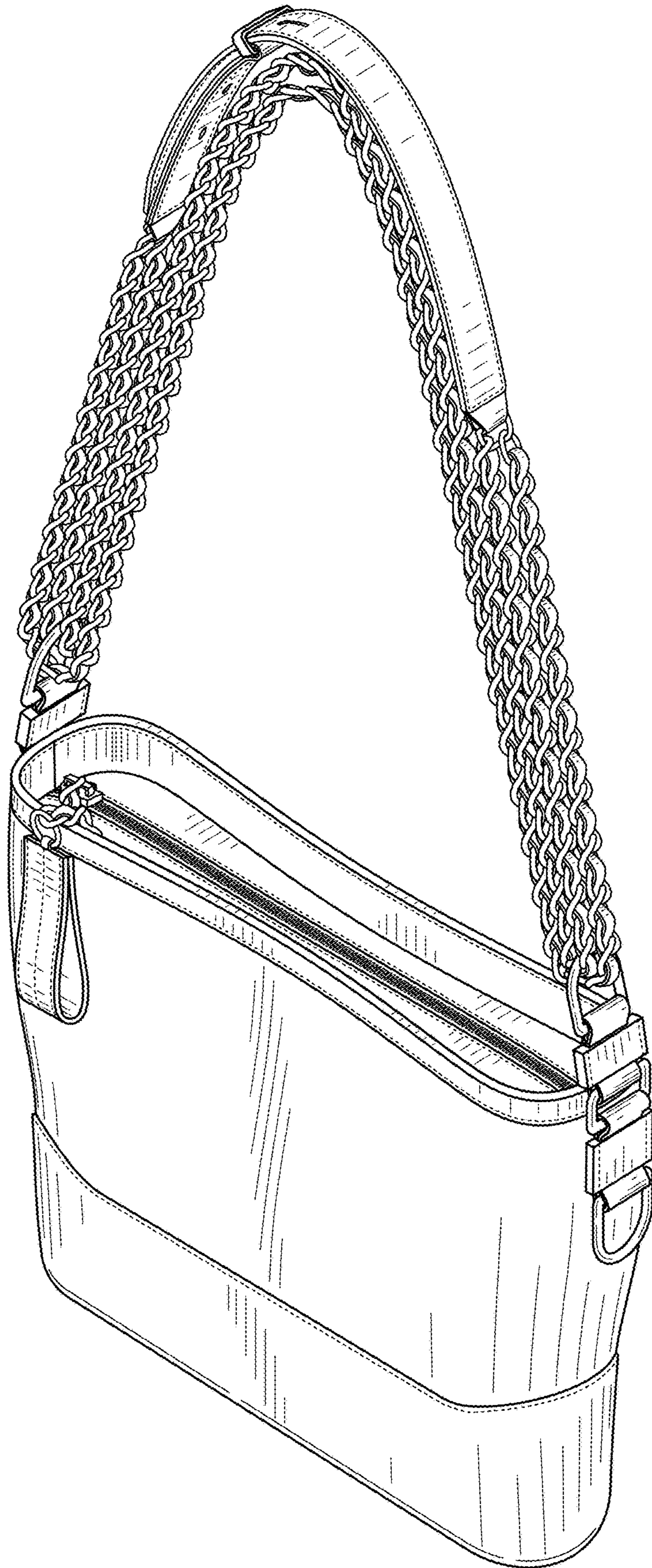

FIG. 8



FIG. 9

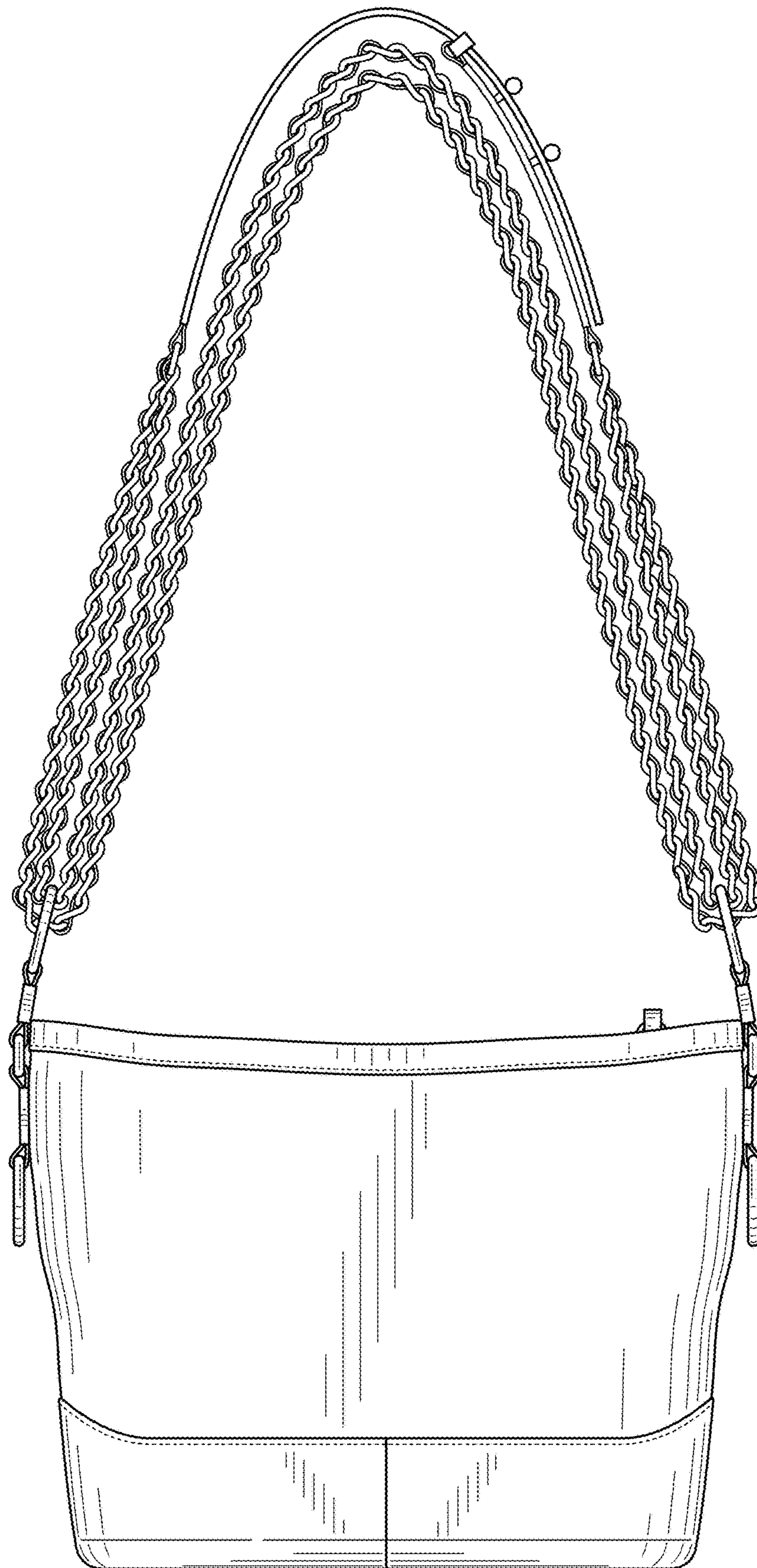

FIG. 10

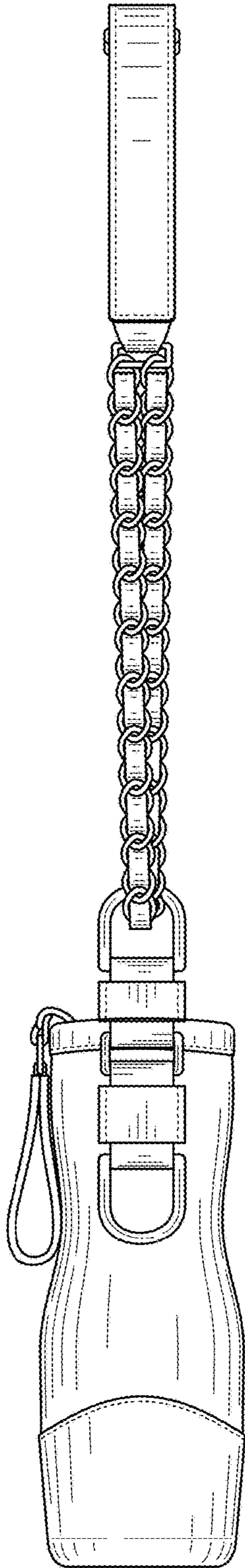

FIG. 11

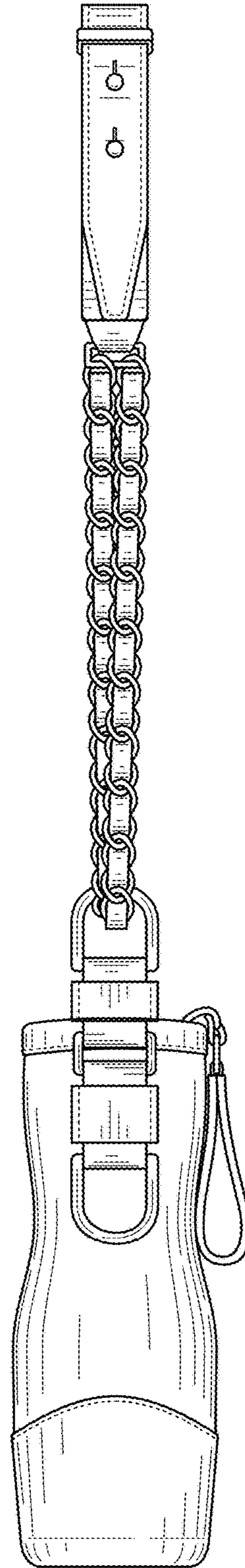

FIG. 12

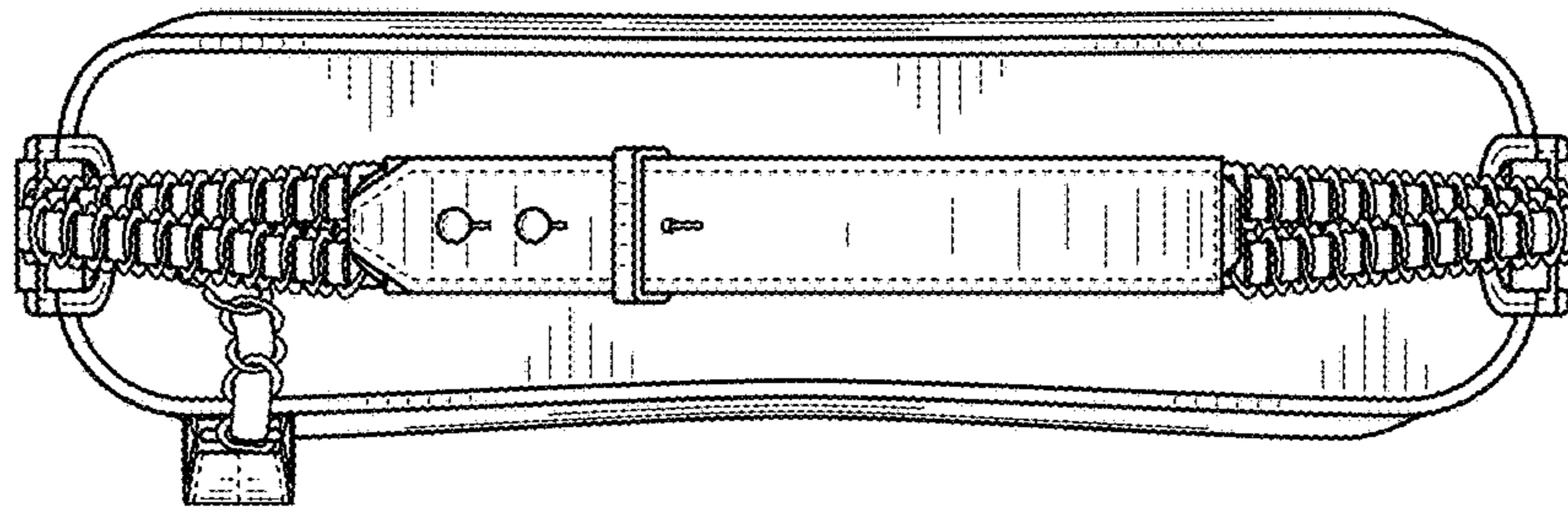

FIG. 13

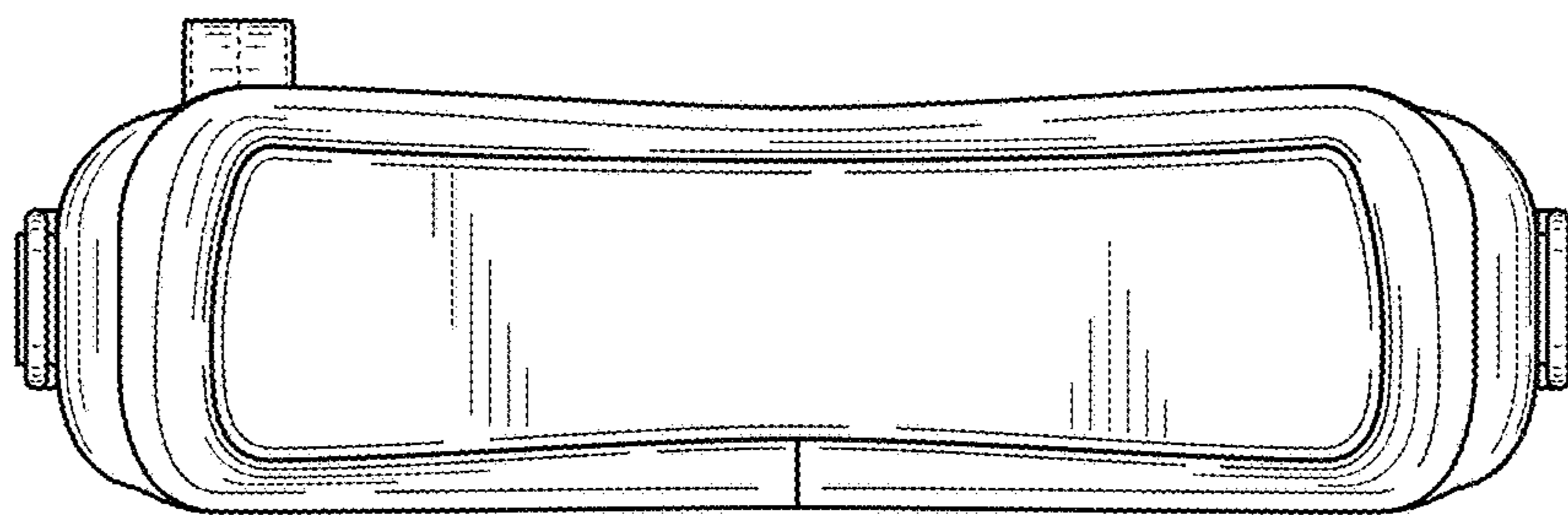

FIG. 14

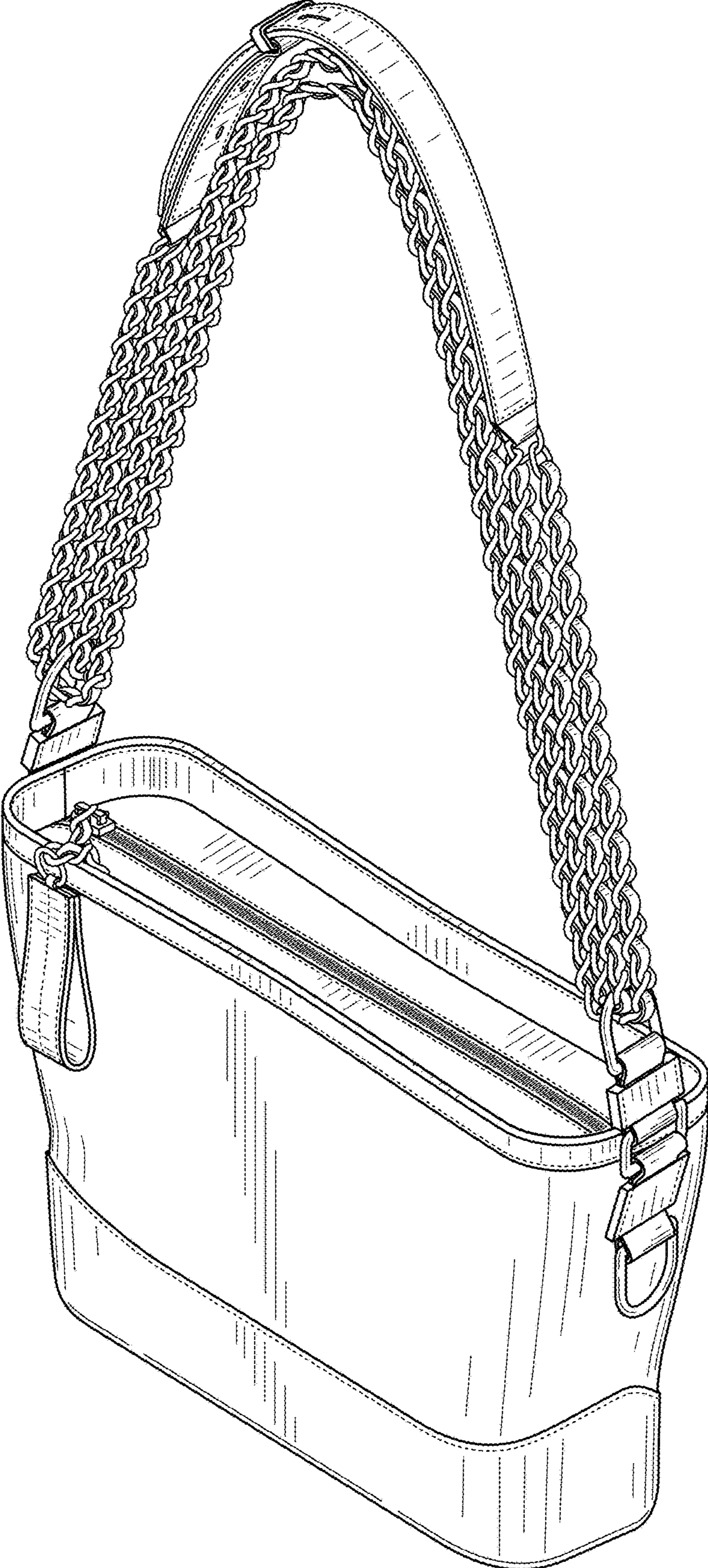

FIG. 15

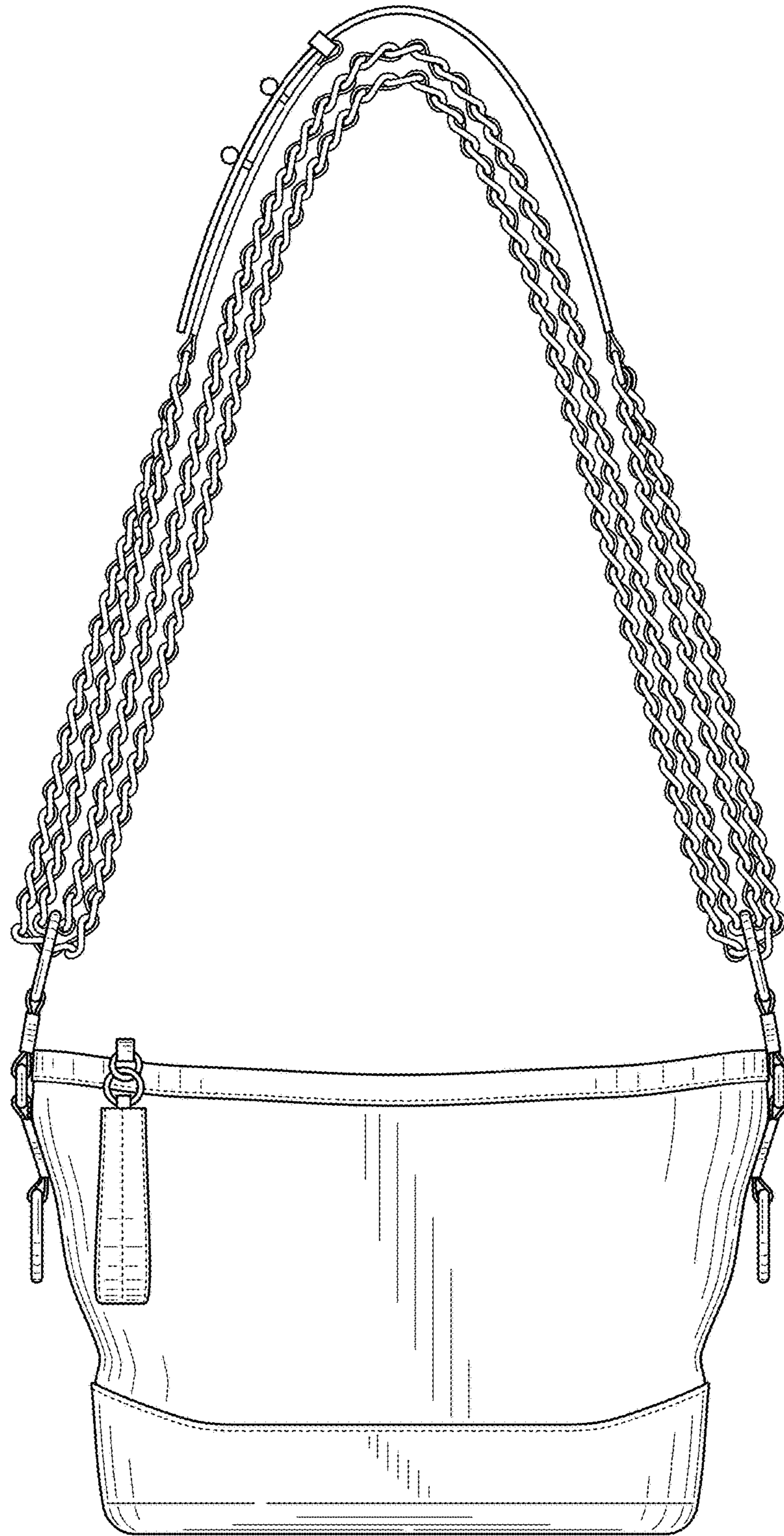

FIG. 16

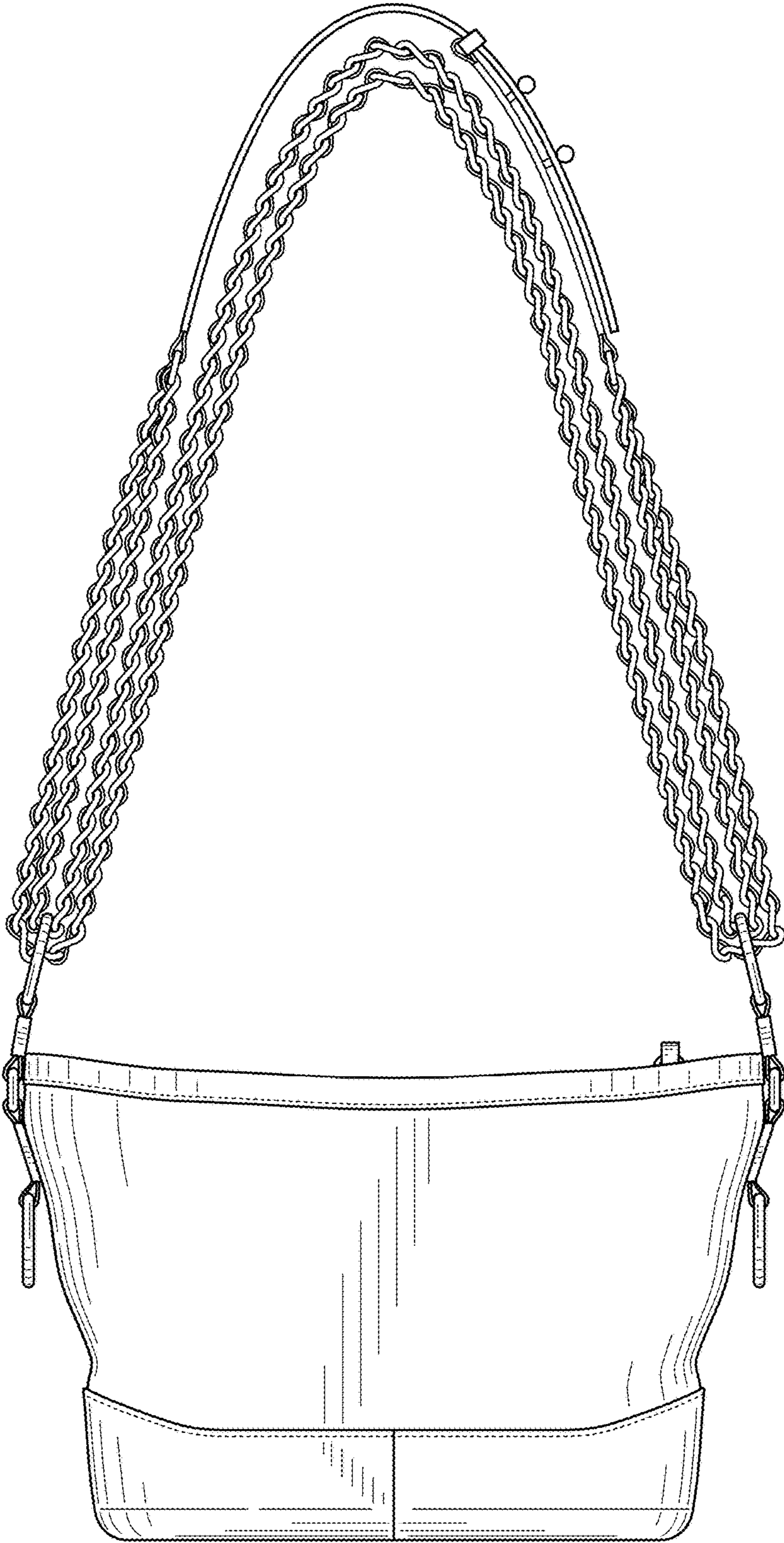

FIG. 17

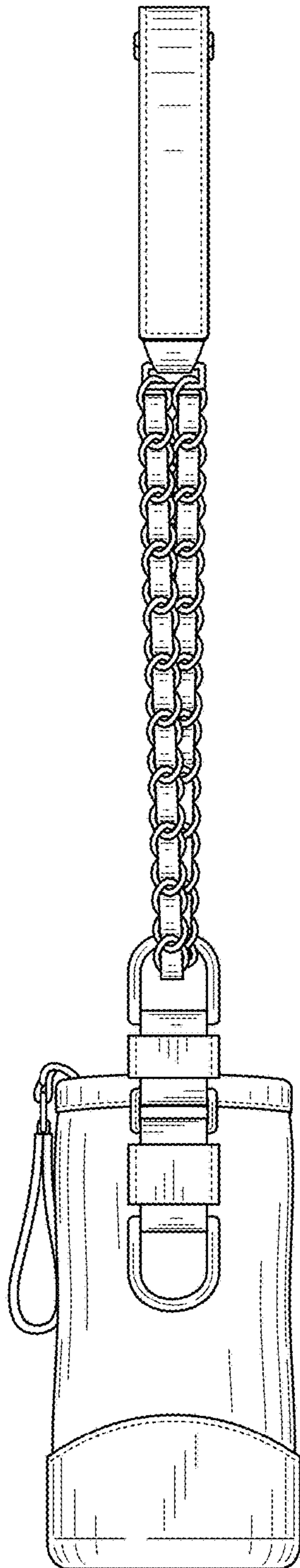

FIG. 18

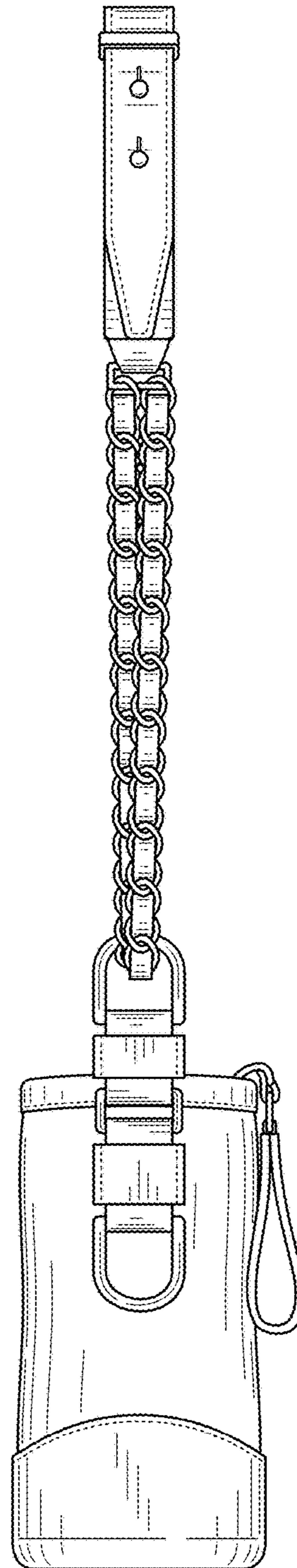

FIG. 19

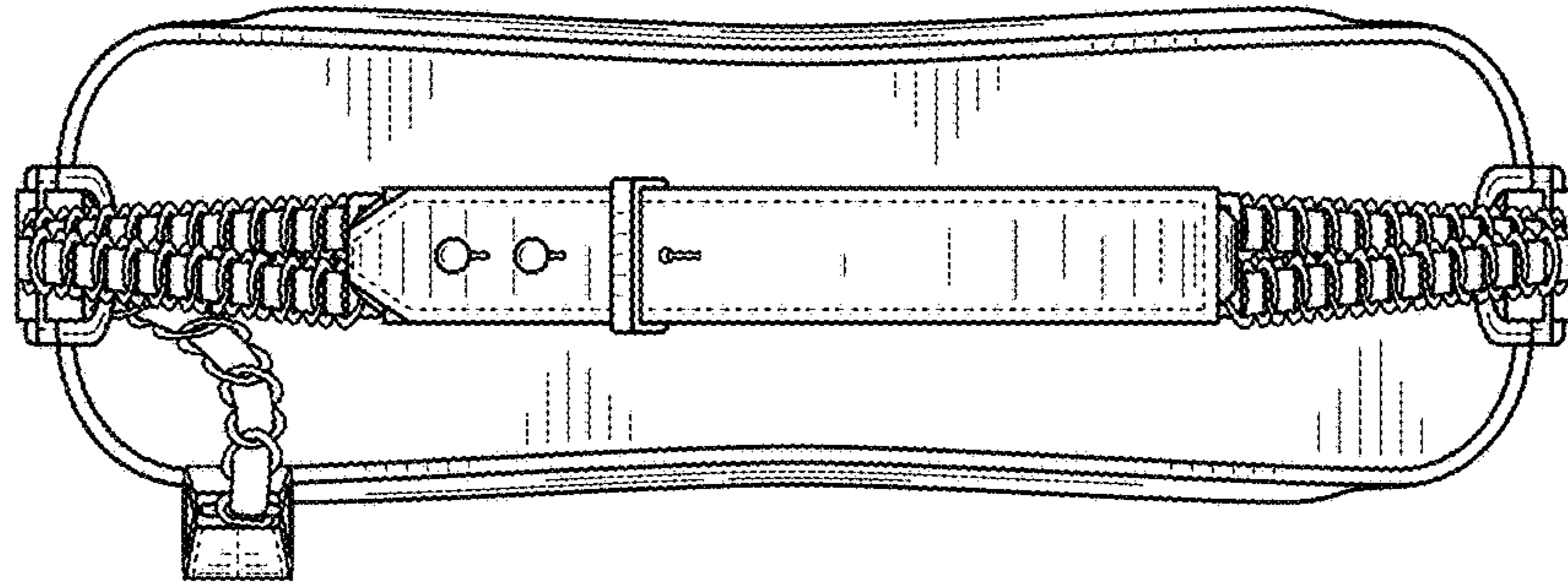

FIG. 20

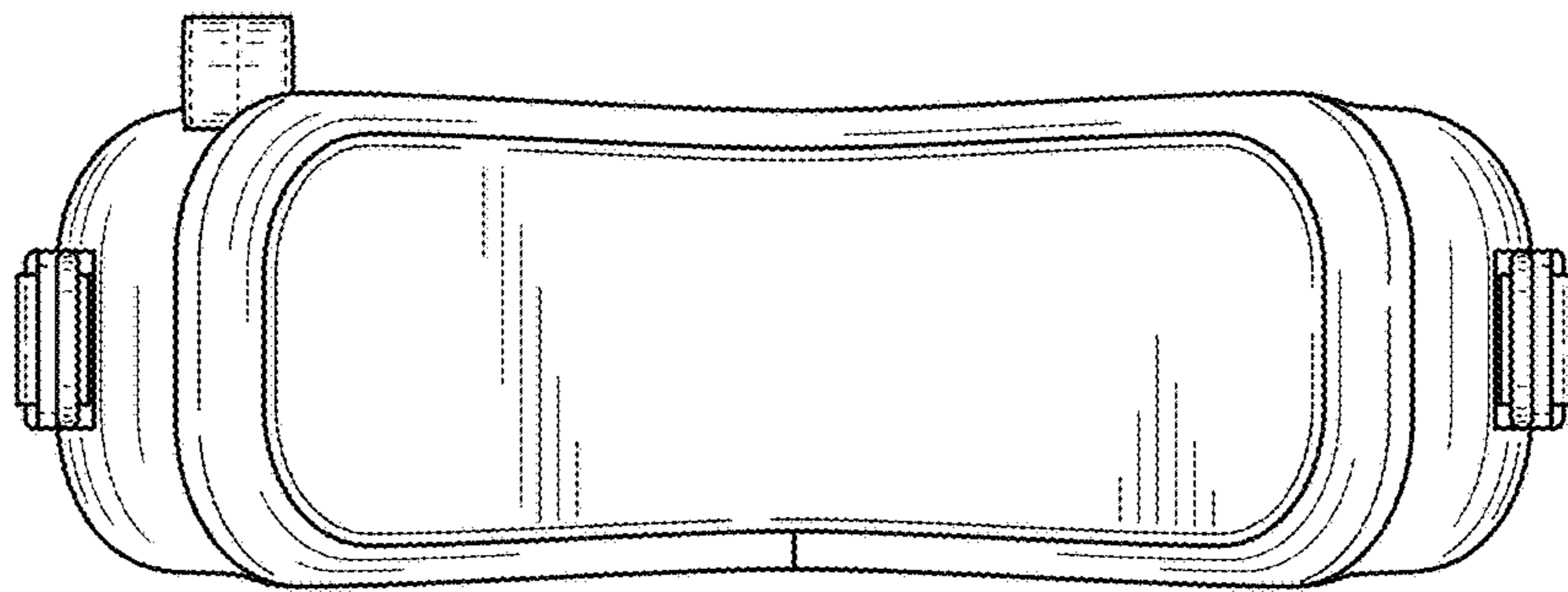

FIG. 21