



US00D847259S

(12) **United States Design Patent** (10) **Patent No.:** **US D847,259 S**
Lozano et al. (45) **Date of Patent:** **** Apr. 30, 2019**

(54) **THERAPEUTIC PEN SUPPORT**

FOREIGN PATENT DOCUMENTS

(71) Applicants: **Karen Lozano**, McAllen, TX (US);
Rodolfo Becerra, Pharr, TX (US);
Carlos Hernandez, Hidalgo, TX (US);
Misael Martinez, McAllen, TX (US);
Arnoldo Ventura, Hidalgo, TX (US)

WO WO/15/003133 1/2015
WO WO/15/164128 10/2015

OTHER PUBLICATIONS

(72) Inventors: **Karen Lozano**, McAllen, TX (US);
Rodolfo Becerra, Pharr, TX (US);
Carlos Hernandez, Hidalgo, TX (US);
Misael Martinez, McAllen, TX (US);
Arnoldo Ventura, Hidalgo, TX (US)

Ahmad, et al., "Reviews on various inertial measurement unit (IMU) sensor applications" Int J Signal Processing Systems. 1(2): 256-262, 2013.

(Continued)

(73) Assignee: **THE BOARD OF REGENTS OF THE UNIVERSITY OF TEXAS SYSTEM**, Austin, TX (US)

Primary Examiner — Elizabeth A. Albert
(74) *Attorney, Agent, or Firm* — Norton Rose Fulbright US LLP

(**) Term: **15 Years**

(57) **CLAIM**

The ornamental design for a therapeutic pen support, as shown and described.

(21) Appl. No.: **29/602,238**

DESCRIPTION

(22) Filed: **Apr. 28, 2017**

(51) **LOC (11) Cl.** **19-06**

(52) **U.S. Cl.**
USPC **D19/84**

(58) **Field of Classification Search**
USPC D19/32, 75, 77-85, 135, 202-204;
D3/315, 901, 206; D6/677.3; D7/590,
D7/641; D9/415, 457, 722; D28/73;
D20/28, 40, 42
CPC .. B43K 23/001; B43K 23/002; B43K 23/004;
B43K 23/008; B43K 23/012; B43K
23/016; B43K 23/04; B43M 99/006;
B43M 99/008

See application file for complete search history.

FIG. 1 is a perspective view of a first embodiment of a therapeutic pen support showing our new design;
FIG. 2 is a top plan view thereof;
FIG. 3 is a bottom plan view thereof;
FIG. 4 is a left side elevation view thereof;
FIG. 5 is a right side elevation view thereof;
FIG. 6 is a front elevation view thereof;
FIG. 7 is a back elevation view thereof;
FIG. 8 is a perspective view of a second embodiment of a folded therapeutic pen support;
FIG. 9 is a top plan view thereof;
FIG. 10 is a bottom plan view thereof;
FIG. 11 is a left side elevation view thereof;
FIG. 12 is a right side elevation view thereof;
FIG. 13 is a front elevation view thereof; and,
FIG. 14 is a back elevation view thereof.

The broken lines in the drawings are included to show portions of the therapeutic pen support that form no part of the claimed design.

(56) **References Cited**

U.S. PATENT DOCUMENTS

D132,902 S * 6/1942 Barofsky D14/149
D145,734 S * 10/1946 Kendrick D19/79

(Continued)

1 Claim, 6 Drawing Sheets

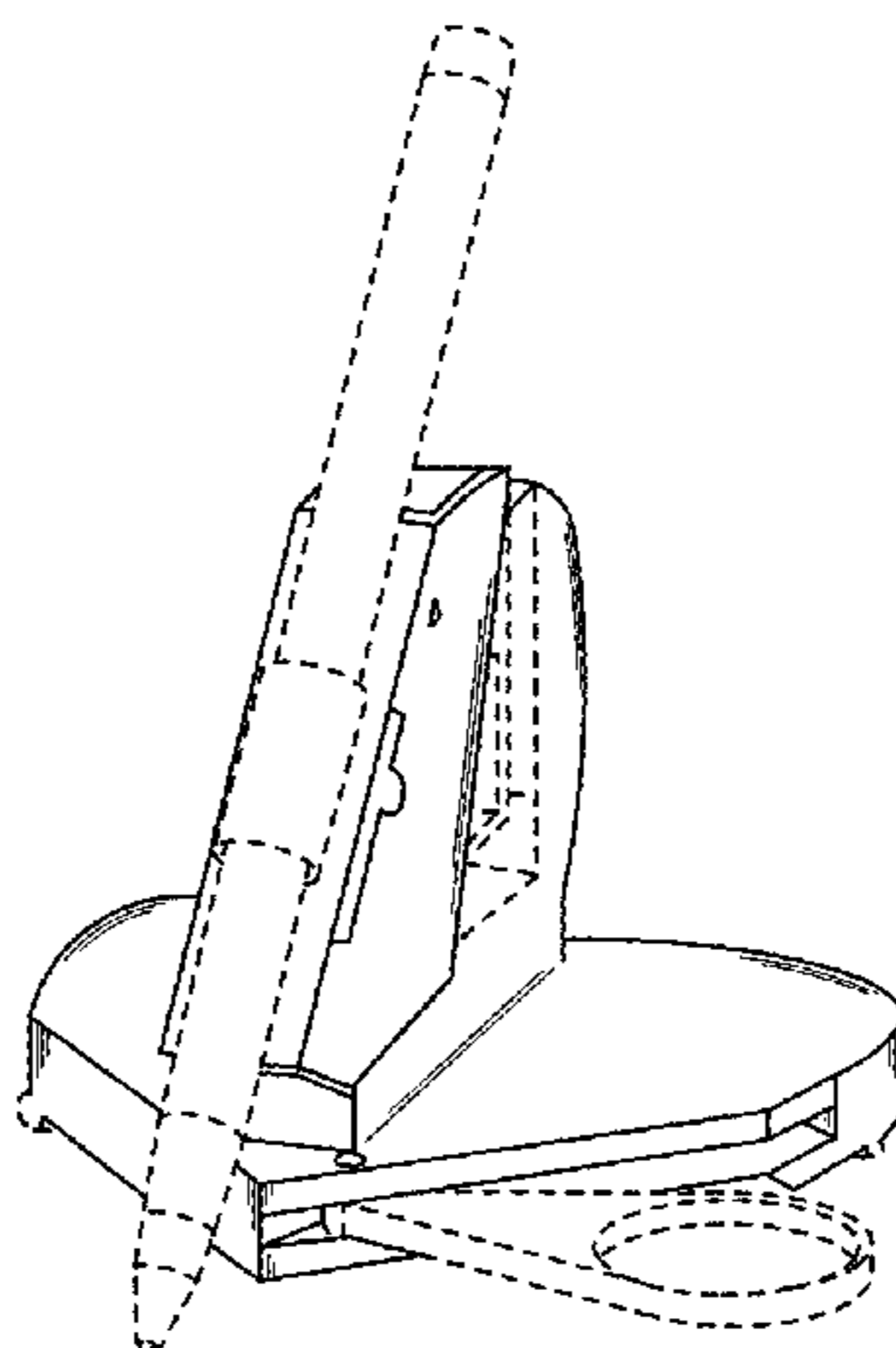

(56)

References Cited

U.S. PATENT DOCUMENTS

2,583,567	A *	1/1952	Hanson	B43M 99/001 131/238
2,593,244	A *	4/1952	Batcha	B43K 23/04 273/161
2,807,886	A *	10/1957	Aciego	G01B 3/1084 33/572
3,148,455	A *	9/1964	Aciego	B25H 7/04 33/668
3,972,628	A	8/1976	Stevens	401/48
4,015,337	A *	4/1977	Taylor	B25H 7/04 33/27.03
4,296,554	A *	10/1981	Hammerstrom	B43K 23/001 33/32.5
5,165,814	A	11/1992	Buda	401/195
6,213,961	B1	4/2001	Reinsma	601/80
6,458,089	B1	10/2002	Ziv-Av	600/595
6,695,794	B2	2/2004	Kaiser et al.	600/595
6,725,560	B2 *	4/2004	Smith	G01B 3/1084 33/668
6,854,913	B2	2/2005	Farrell et al.	402/195
7,500,322	B2 *	3/2009	Brown	G01B 3/1084 33/668
8,308,664	B2	11/2012	Pathak et al.	600/595
2001/0012932	A1	8/2001	Peer	606/1
2014/0340326	A1	11/2014	Kameyama et al.	345/173
2015/0300394	A1	10/2015	Pathak	

OTHER PUBLICATIONS

Atif & Serdaroglu "A measurement system for human movement analysis" Masters thesis from Chalmers University of Technology, 2011.

Bova, et al., "Chiropractic management of an 81 year old man with Parkinson disease signs and symptoms" *J Chiro Med.* 13:116-20, 2014.

Bruel & Kjaer, *Measuring Vibration* booklet, 1982.

Bume, et al., "The contribution of tremor studies to diagnosis of Parkinsonian and essential tremor: a statistical evaluation" *J Clin Neurosci.* 9(3):237-42, 2002.

Chowdhury, et al., "Development of a MEMS accelerometer based hand tremor stabilization platform" *Int J Biotech Biomed Sci.* 2(2):142-5, 2016.

Cristea, et al., "The simulation of vibration attenuation in the hand-arm system" *UPB Sci Bull, Series D.* 75(3), 2013.

Dai, et al., "Quantitative assessment of Parkinsonian tremor based on an inertial measurement unit" *Sensors.* 15:25055-71, 2015.

Drotar, et al., "Evaluation of handwriting kinematics and pressure for differential diagnosis of Parkinson's disease." *Art Intell in Med.* 67:39-46, 2016.

Graham, "Using an accelerometer sensor to measure human hand motion" Masters Thesis from Massachusetts Institute of Technology, 2000.

Grippi, et al., "PD Analytics: A wearable device to monitor and quantify motor dysfunction in patients with Parkinson's disease" Sonoma State University, 2015.

Hashemi, et al., Tunedvibration absorber for suppression of rest tremor in Parkinson's disease: *Med Biol Eng Comput.* 42:61-70, 2004.

Hedge "Human vibration" from Cornell University, 2013.

Henderson, "An inertial measurement system for hand and finger tracking" Masters Thesis from Boise State University, 2011.

Herekar, et al., ET vs Parkinson's Disease: How do they differ?, 2010.

Hjort & Holmberg, "Measuring mechanical vibrations using an Arduino as a slave I/O to an EPICS control system" Uppsala University, 2015.

Jankovic, et al., "Distinguishing essential tremor from Parkinson's disease" *Practical Neurology*, 2012.

Lebel, et al., "Autonomous quality control of joint orientation measured with inertial sensors" *Sensors.* 16:1037, 2016.

Meigal, et al., "Linear and nonlinear tremor acceleration characteristics in patients with Parkinson's disease" *Physiol Meas.* 33:395-412, 2012.

Novatel, "IMU errors and their effects" Feb. 21, 2014.

Pathak, "The development of an antagonistic SMA actuation technology for the active cancellation of humor tremor" Masters These from the University of Michigan, 2010.

Rigas, et al., "Assessment of tremor activity in the Parkinson's disease using a set of wearable sensors" *IEEE transaction on information technology in biomedicine.* 16(3):478-487, 2012.

Rodriguez-Martin, et al., "A wearable inertial measurement unit for long-term monitoring in the dependency care area" *Sensors.* 13:14079-104, 2013.

Schwellnus, et al., "Writing forces associate with four pencil grasp patterns in grade 4 children" *Am J Occupational Therap.* 67:218, 27, 2013.

Sharififar, et al., "The effects of whole body vibration on mobility and balance in Parkinson disease: a systematic review" *IJMS.* 39(4):318-326, 2014.

Slifka, "An accelerometer based approach to measuring displacement of a vehicle body" Masters Thesis from the University of Michigan 2004.

Teixeira, et al., "A self-tunable dynamic vibration absorber" UKSim 15th international conference on computer modelling and simulation, 2013.

Teskey, et al., "Inertial sensing to determine movement disorder motion present before and after treatment" *Sensors,* 12:3512-27, 2012.

Tzallas, et al., "PERFORM: A system for monitoring, assessment and management of patients with Parkinson's disease" *Sensors.* 14:21329-57, 2014.

Varanis, et al., "Instrumentation for mechanical vibrations analysis in the time domain and frequency domain using the Arduino platform" *Revista Brasileira de Ensino de Fisica.* 38(1):1301, 2016.

Various, *J Neurol Sci.* 333:e537-8, 2013.

Verily Life Sciences, "Liftware Starter Kit Product Handbook," 2016.

Walker, et al., "Could a new sensory pen assist in the early diagnosis of Parkinson's?" *Exp Rev Med Dev.* 11:3: 243-45, 2014.

Wehner, et al., "From concept to commercialization: the real challenge for medical device entrepreneurs" *Regulatory Focus:* 47-52, 2010.

* cited by examiner

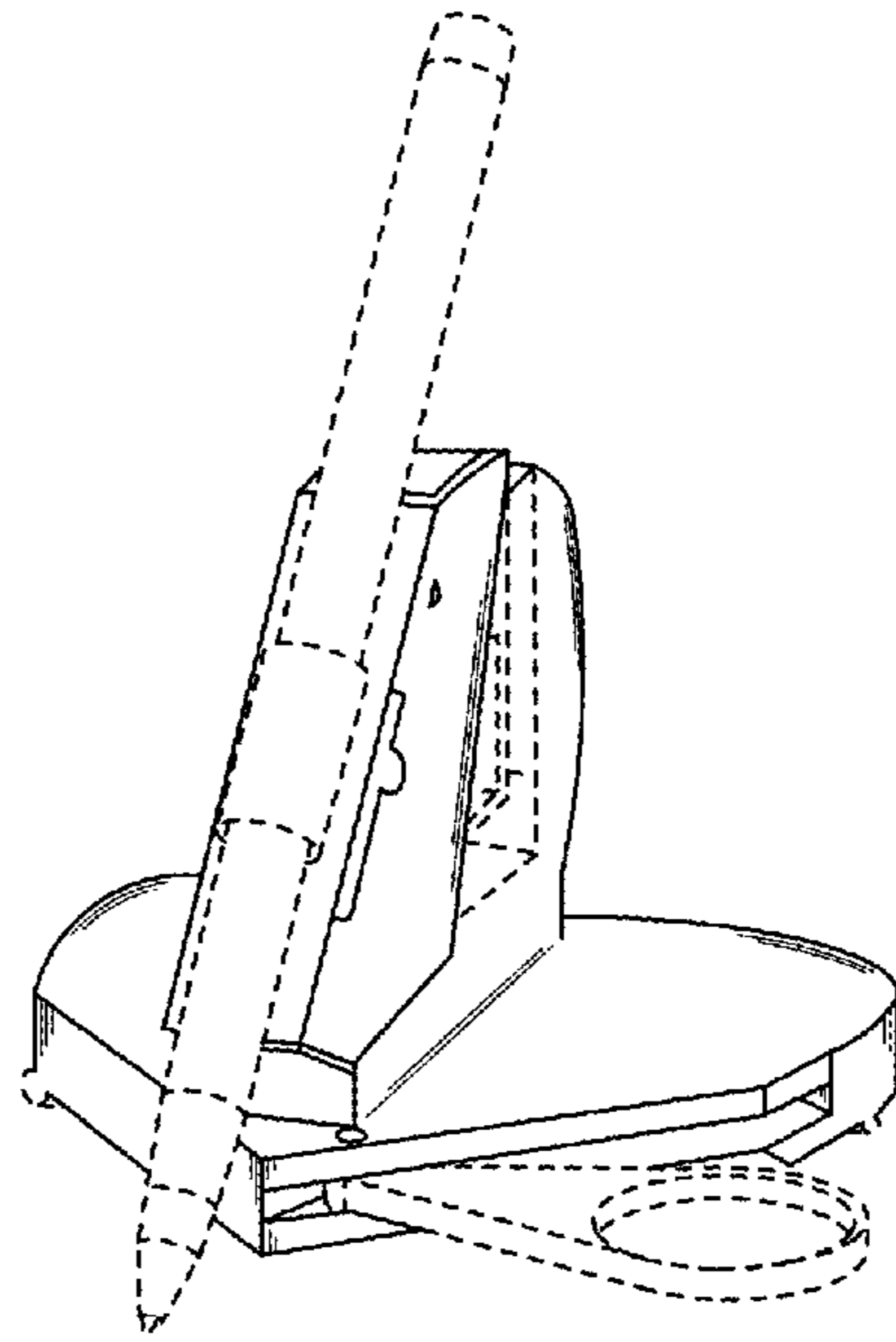

FIG. 1

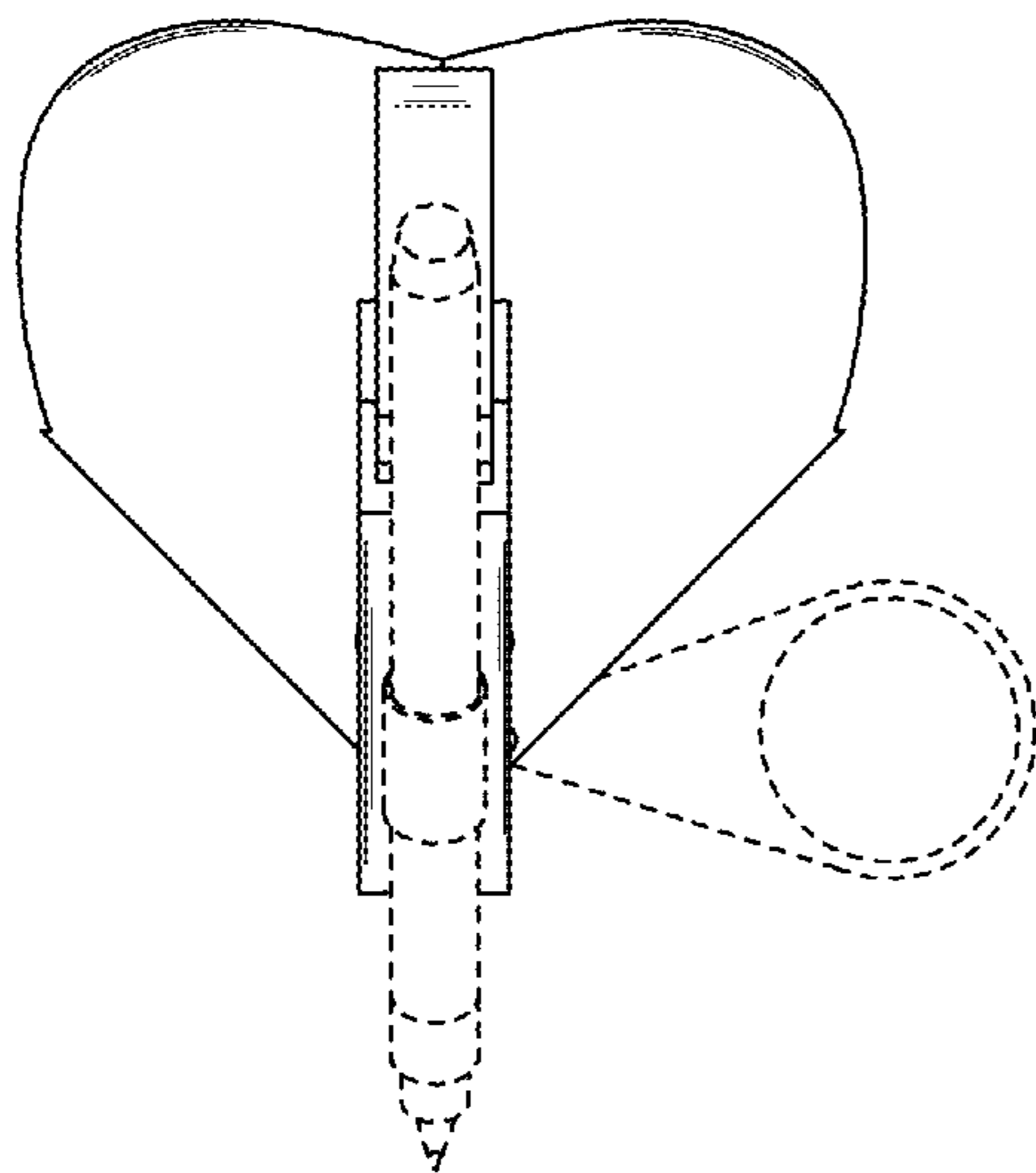

FIG. 2

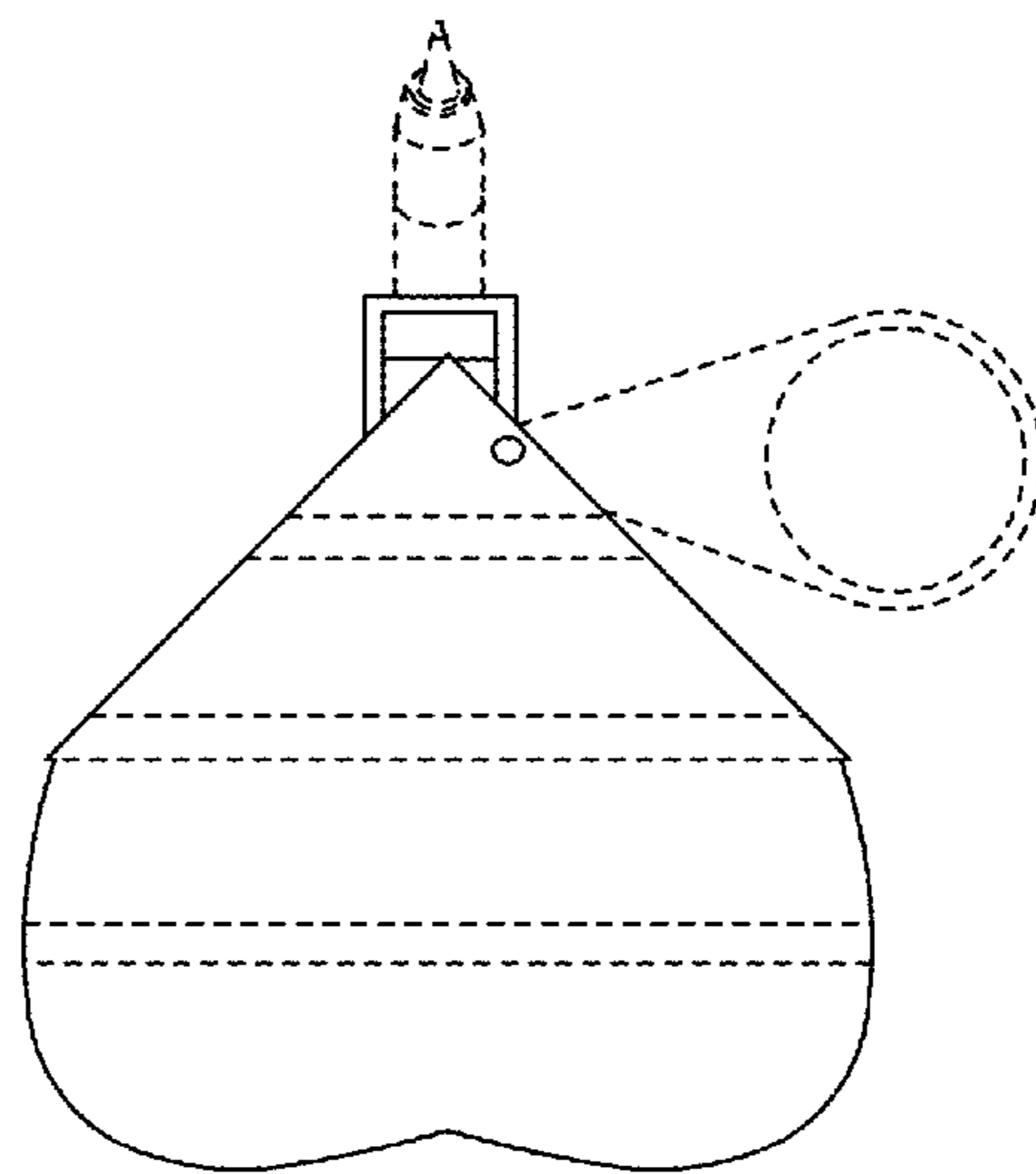

FIG. 3

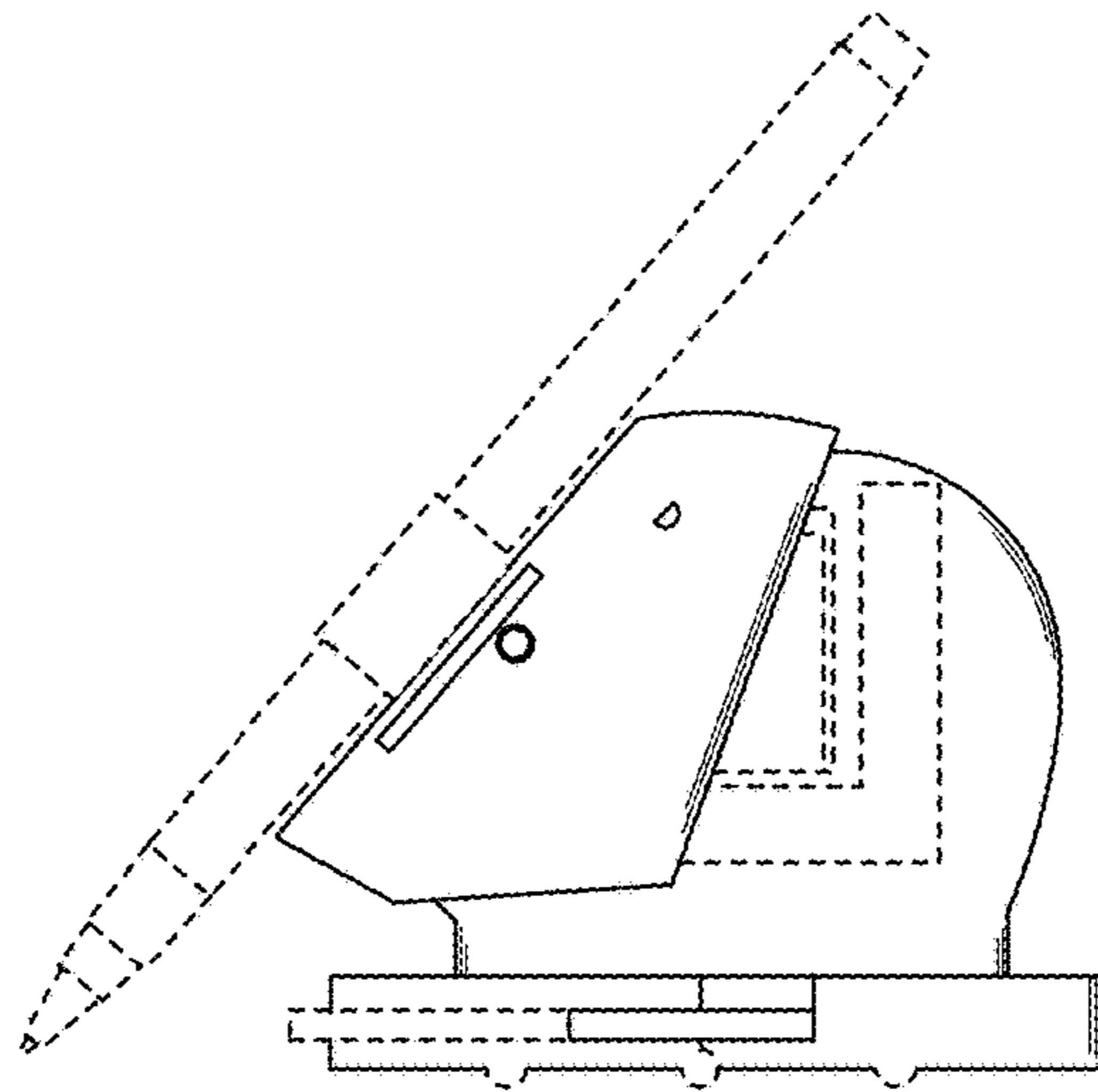

FIG. 4

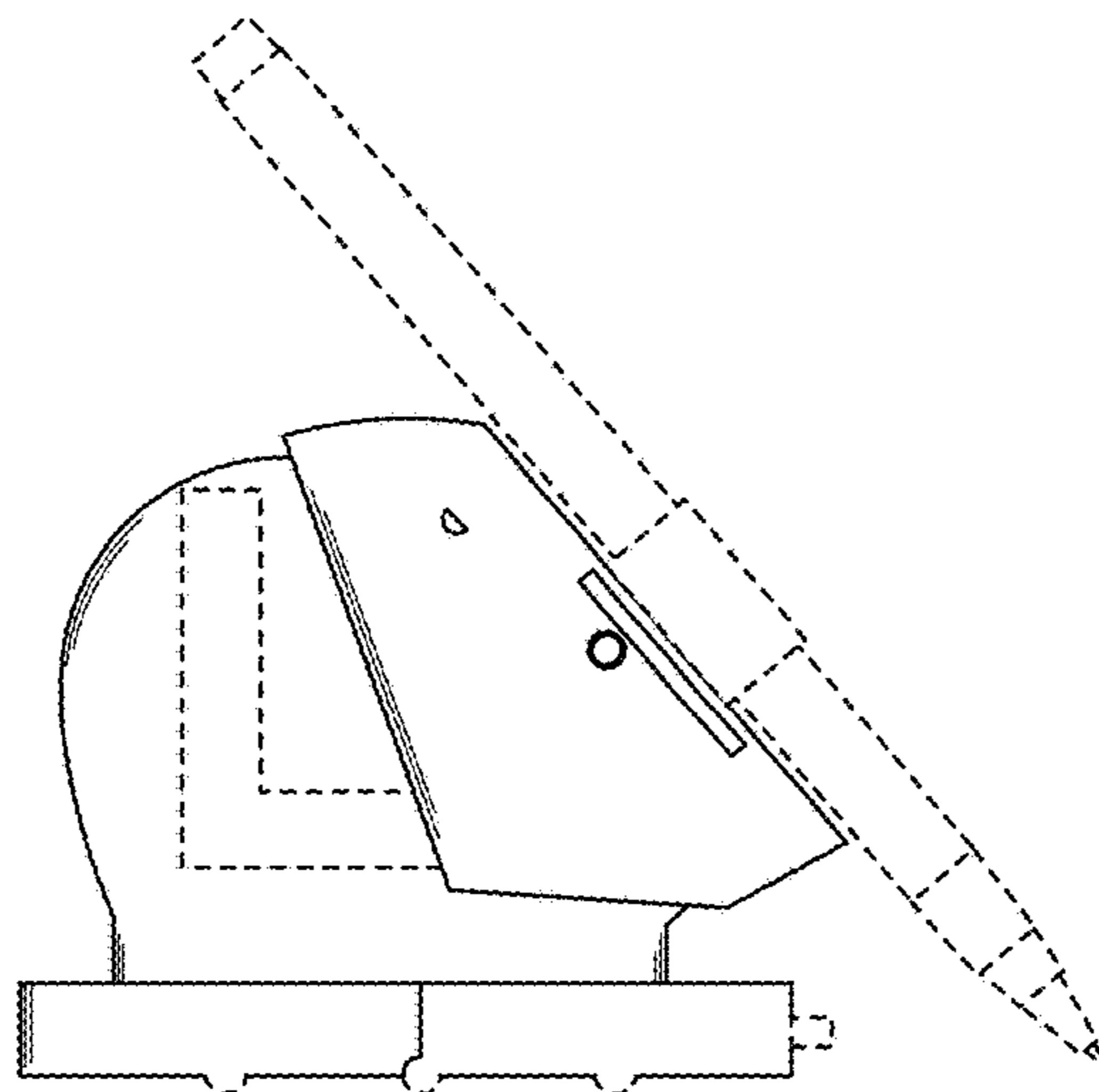

FIG. 5

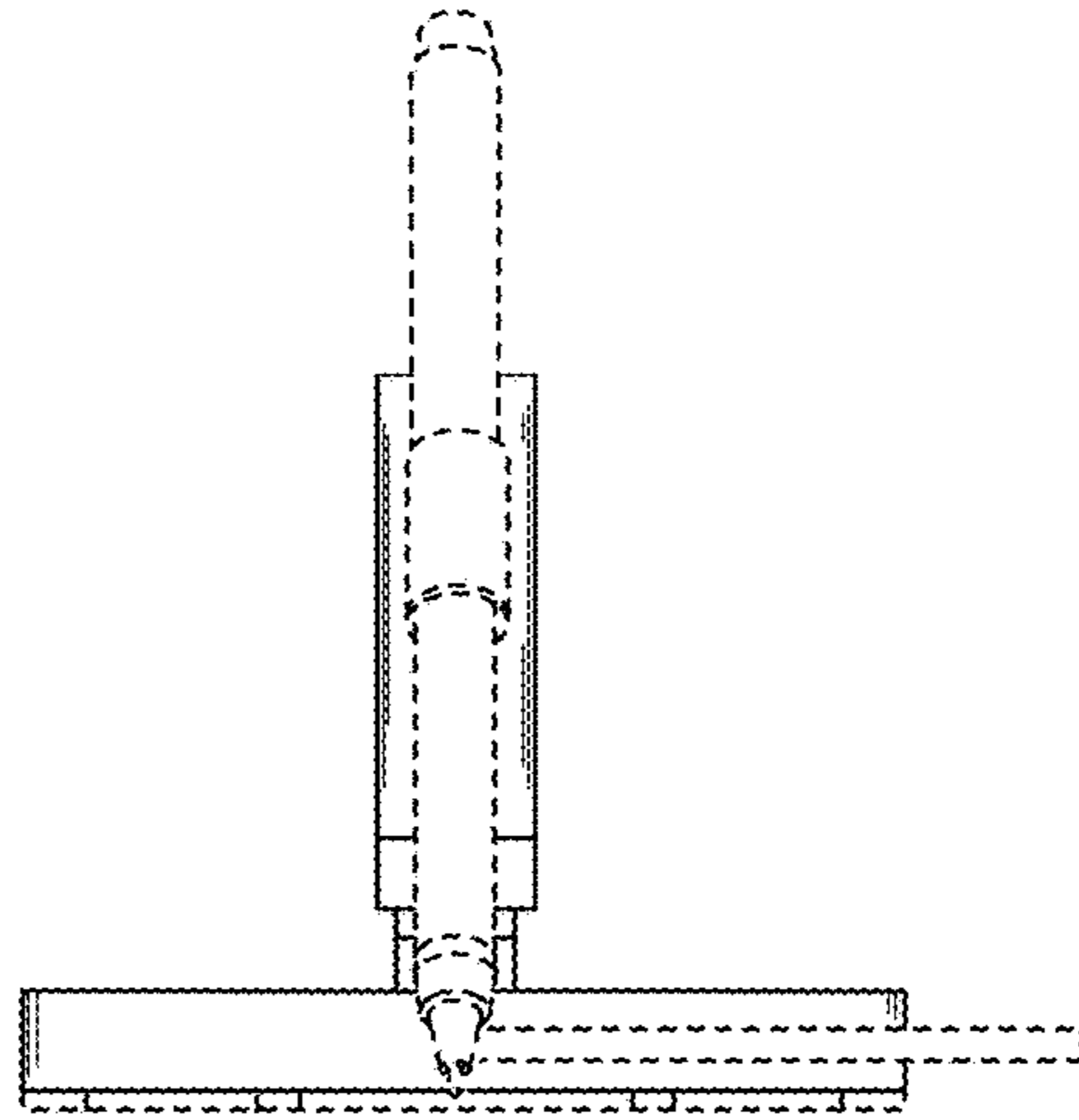

FIG. 6

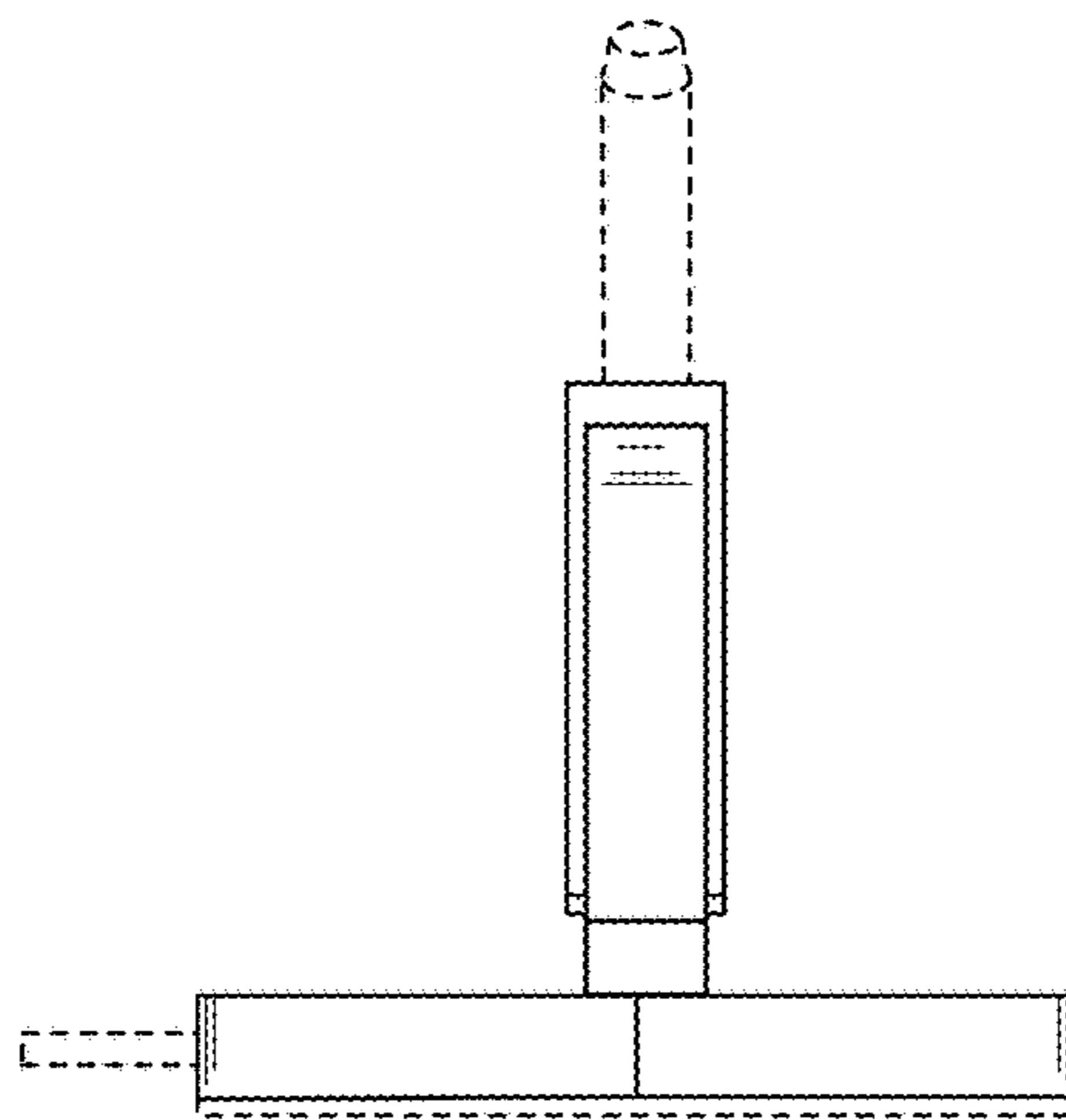

FIG. 7

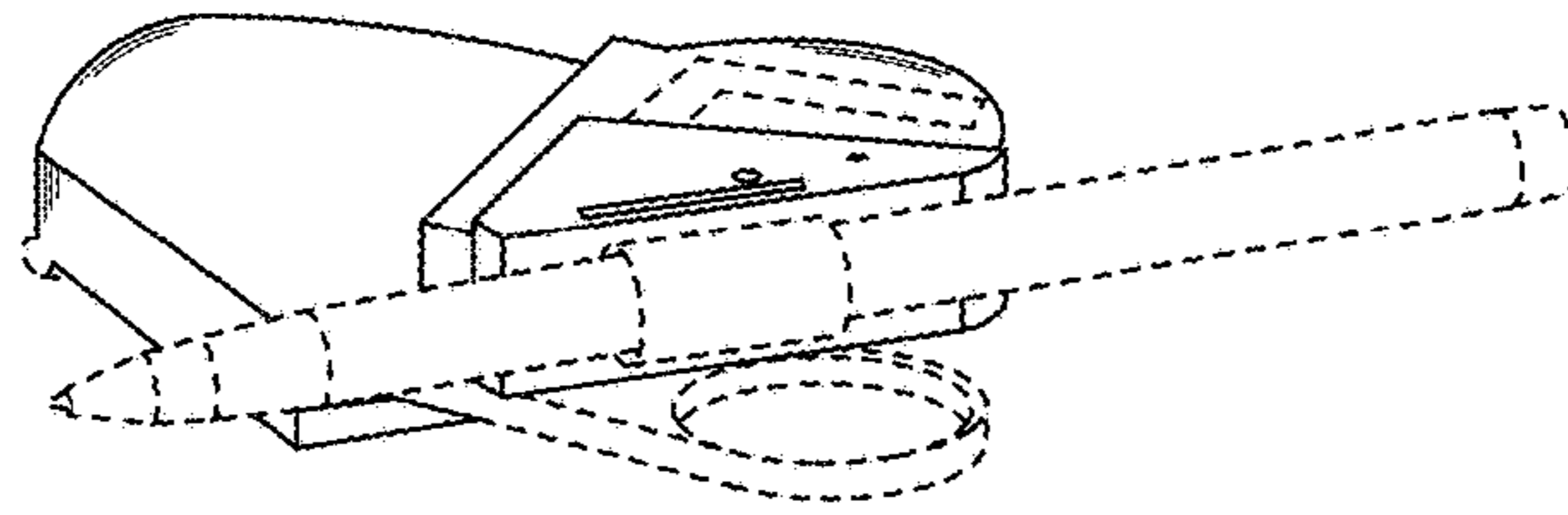

FIG. 8

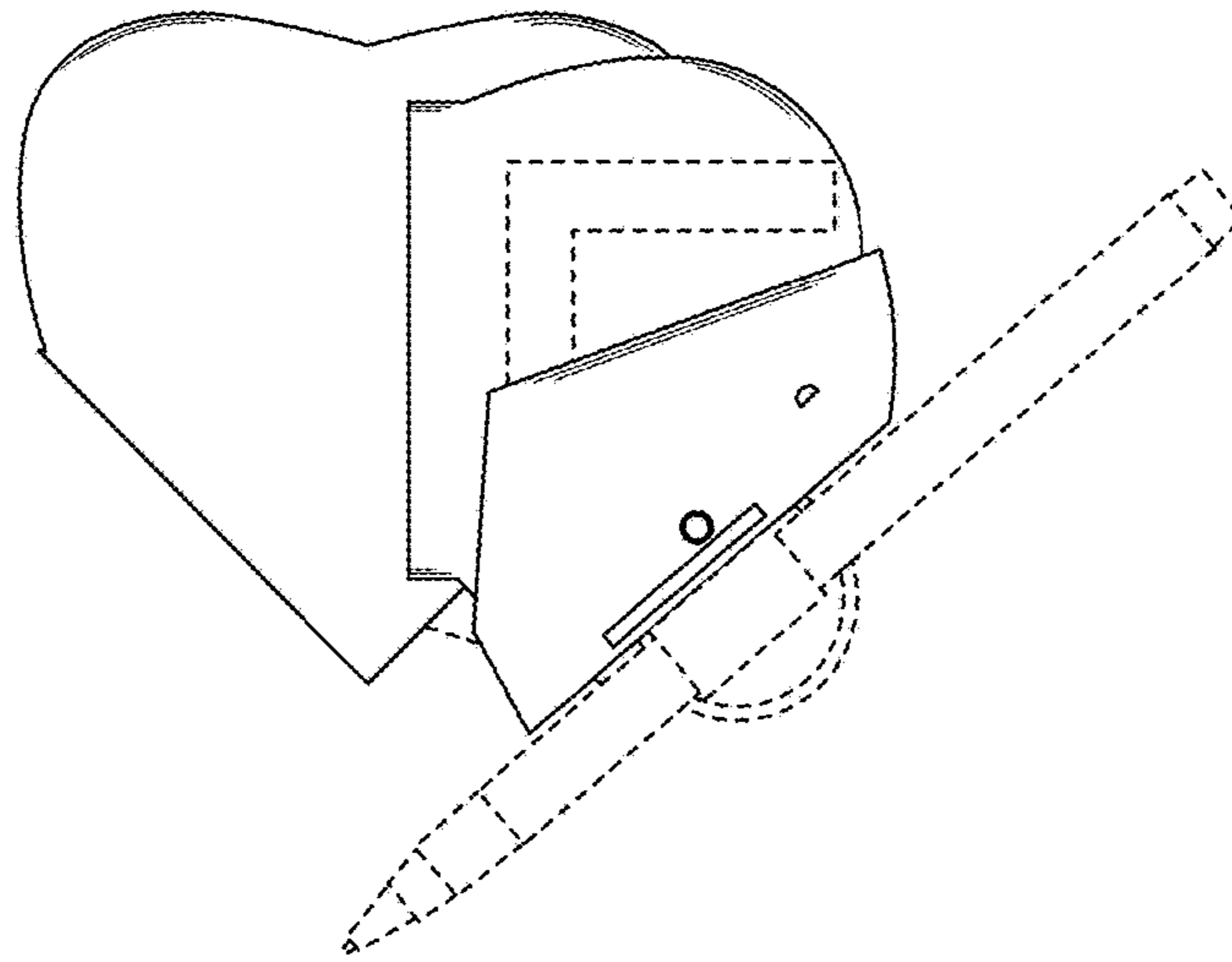

FIG. 9

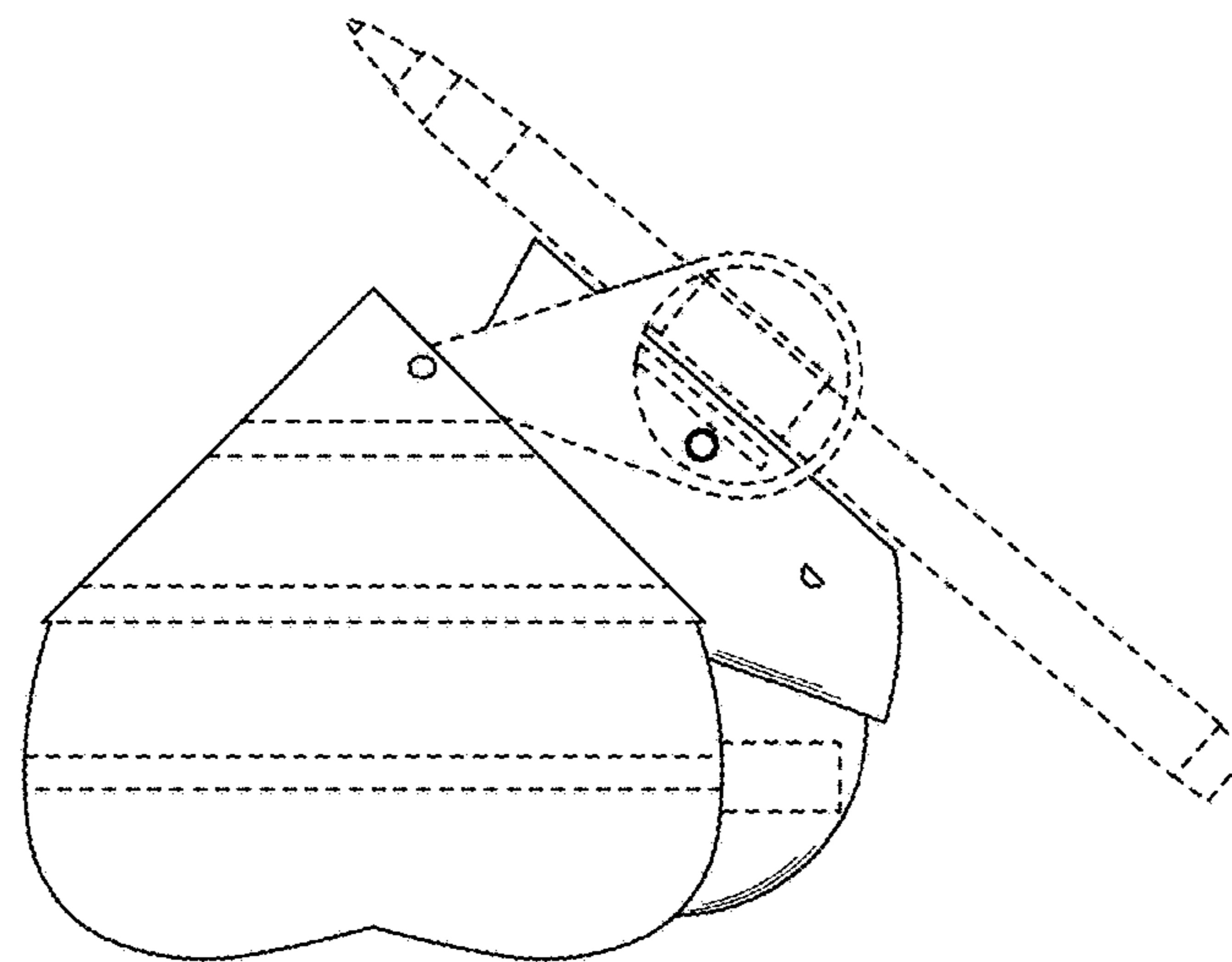

FIG. 10

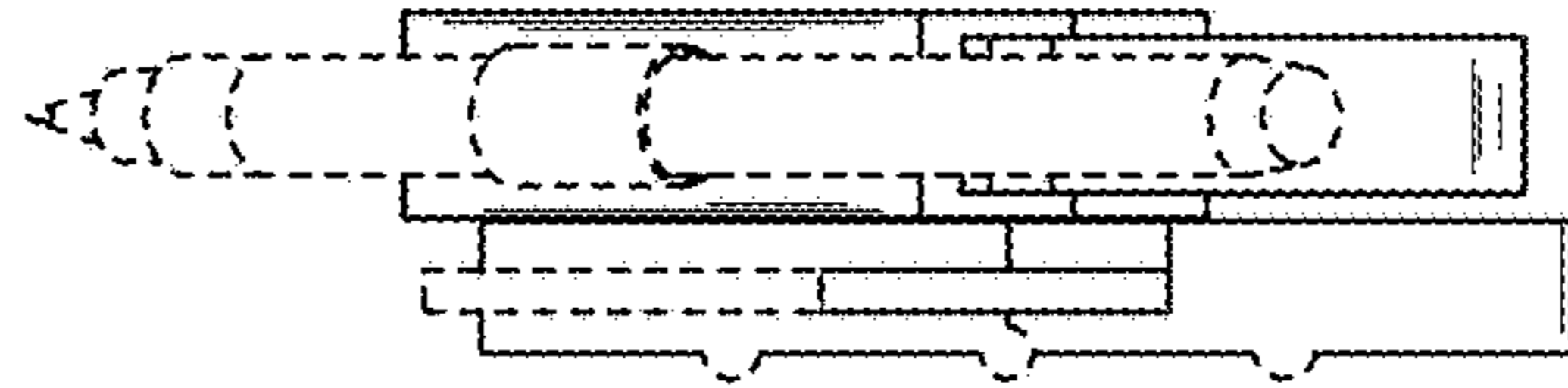

FIG. 11

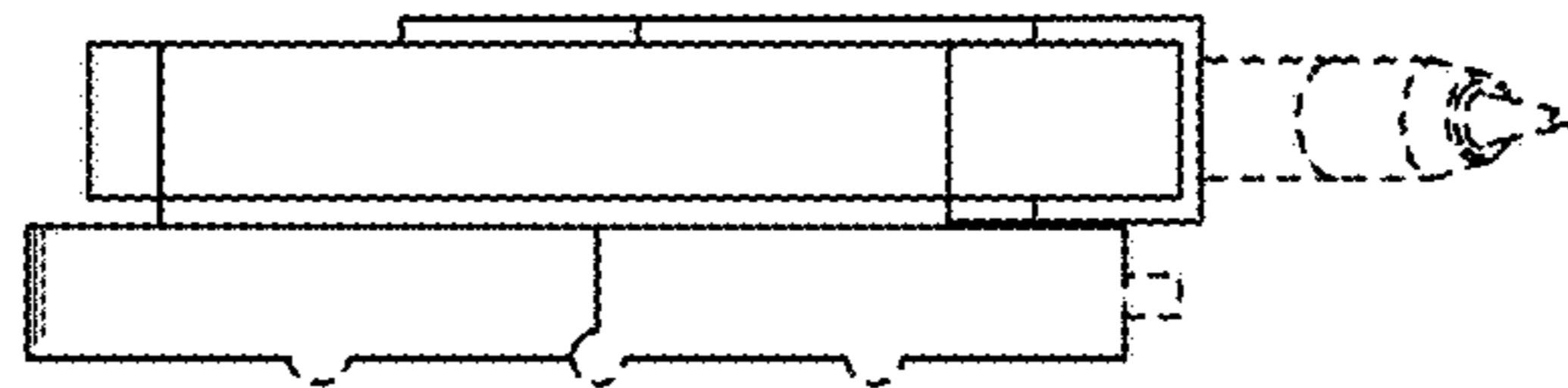

FIG. 12

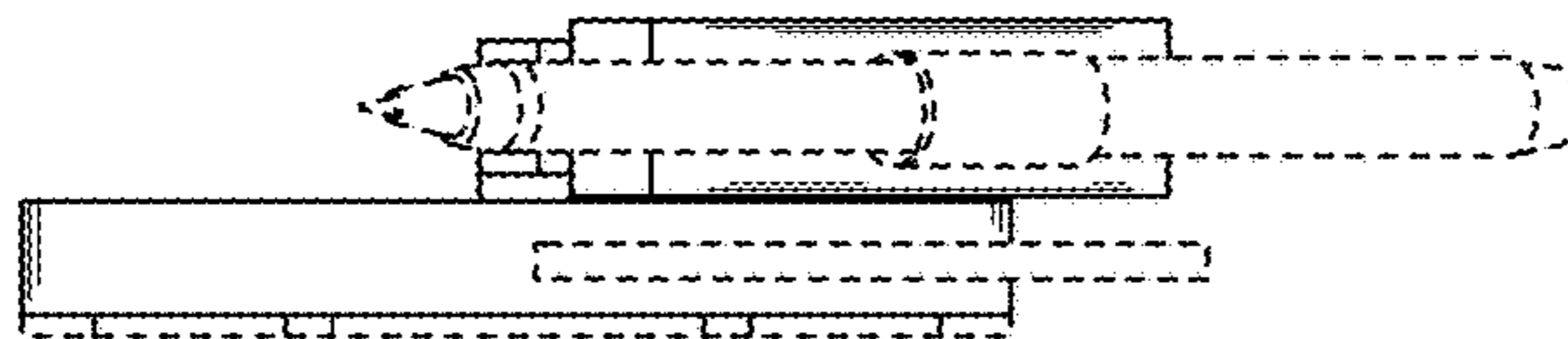

FIG. 13

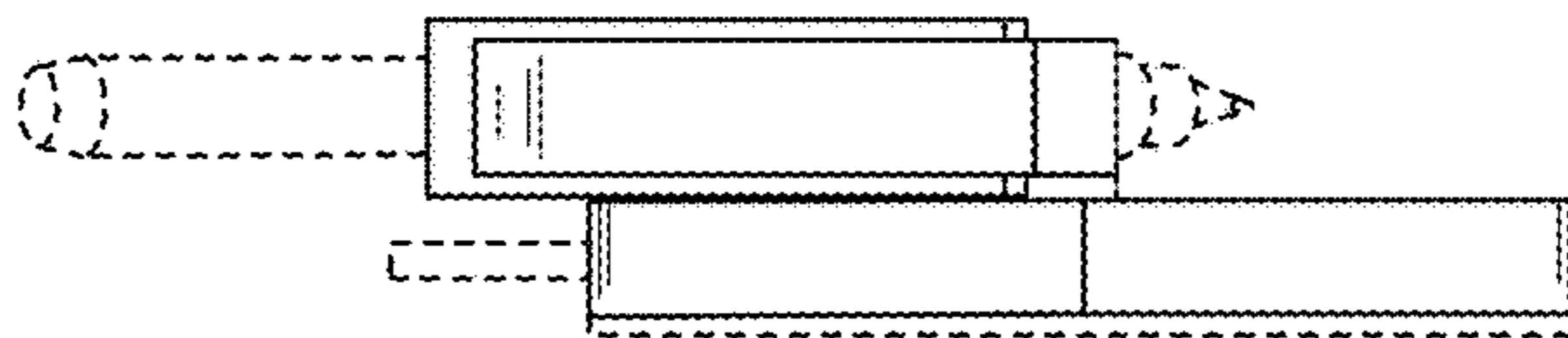

FIG. 14