

US00D847077S

(12) **United States Design Patent**
Säkkinen et al.

(10) **Patent No.:** **US D847,077 S**

(45) **Date of Patent:** **** Apr. 30, 2019**

(54) **PROPULSION UNITS FOR SHIPS AND BOATS**

(71) Applicant: **ABB Schweiz AG**, Baden (CH)

(72) Inventors: **Petri Säkkinen**, Espoo (FI); **Mikael Lindfors**, Helsinki (FI); **Pasi Miettinen**, Espoo (FI); **Lasse Lahtinen**, Vantaa (FI)

(73) Assignee: **ABB Schweiz AG** (CH)

(**) Term: **15 Years**

(21) Appl. No.: **29/596,548**

(22) Filed: **Mar. 9, 2017**

Related U.S. Application Data

(62) Division of application No. 35/500,629, filed on Aug. 20, 2015 (U.S. filing date under 35 U.S.C. 384), and having an international filing date of Aug. 20, 2015, now Pat. No. Des. 791,678.

(51) **LOC (11) Cl.** **12-06**

(52) **U.S. Cl.**
USPC **D12/300**

(58) **Field of Classification Search**
USPC D12/300, 309, 317; D15/4-5
See application file for complete search history.

(56) **References Cited**

U.S. PATENT DOCUMENTS

6,783,409	B2 *	8/2004	Lonngren	B63H 5/125 440/58
7,537,500	B2 *	5/2009	Abdel-Maksoud	B63B 1/042 440/79
8,707,717	B2 *	4/2014	Fox	F25B 9/14 62/115

9,475,565	B2 *	10/2016	Gallato	B63H 5/125
9,476,311	B2 *	10/2016	Krackhardt	B63H 3/06
2003/0000444	A1 *	1/2003	Tsuboguchi	B63H 5/125 114/162
2016/0176488	A1 *	6/2016	Gallato	B63H 5/125 440/53
2016/0229504	A1 *	8/2016	Aasebo	B63H 25/42

* cited by examiner

Primary Examiner — Michael A. Pratt

(74) *Attorney, Agent, or Firm* — Taft, Stettinius & Hollister LLP; J. Bruce Schelkopf

(57) **CLAIM**

The ornamental design for a propulsion unit for ships and boats, as shown and described.

DESCRIPTION

FIG. 1 is a perspective side view of a propulsion unit for ships and boats.

FIG. 2 is a front side view of the propulsion unit shown in FIG. 1.

FIG. 3 is a back side view of the propulsion unit shown in FIG. 1.

FIG. 4 is a top side view of the propulsion unit shown in FIG. 1.

FIG. 5 is a bottom side view of the propulsion unit shown in FIG. 1.

FIG. 6 is a right side view of the propulsion unit shown in FIG. 1; and,

FIG. 7 is a left side view of the propulsion unit shown in FIG. 1.

The broken lines showing the propeller blades are for the purpose of illustrating portions of the propulsion unit for ships and boats that form no part of the claimed design.

1 Claim, 7 Drawing Sheets

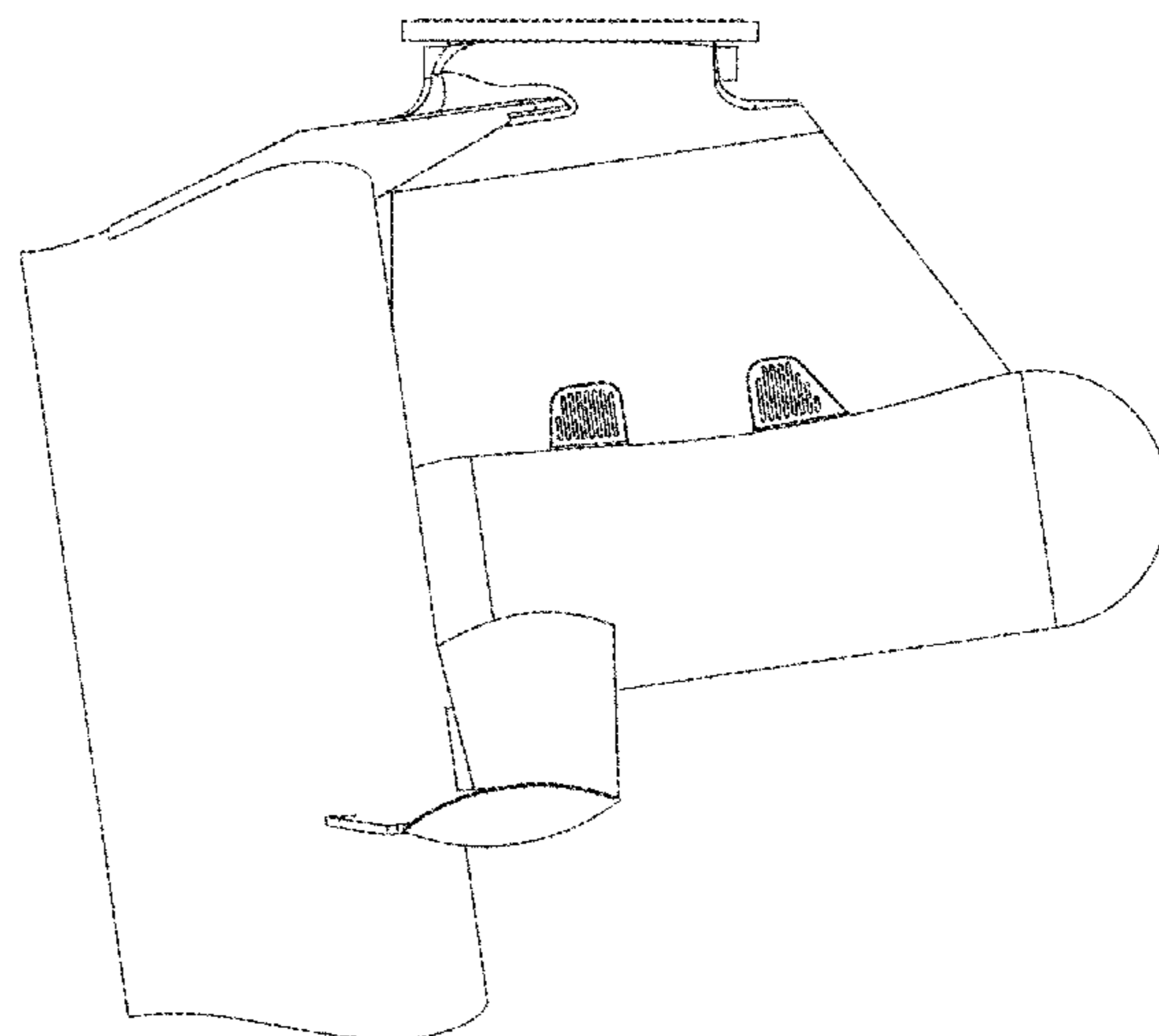
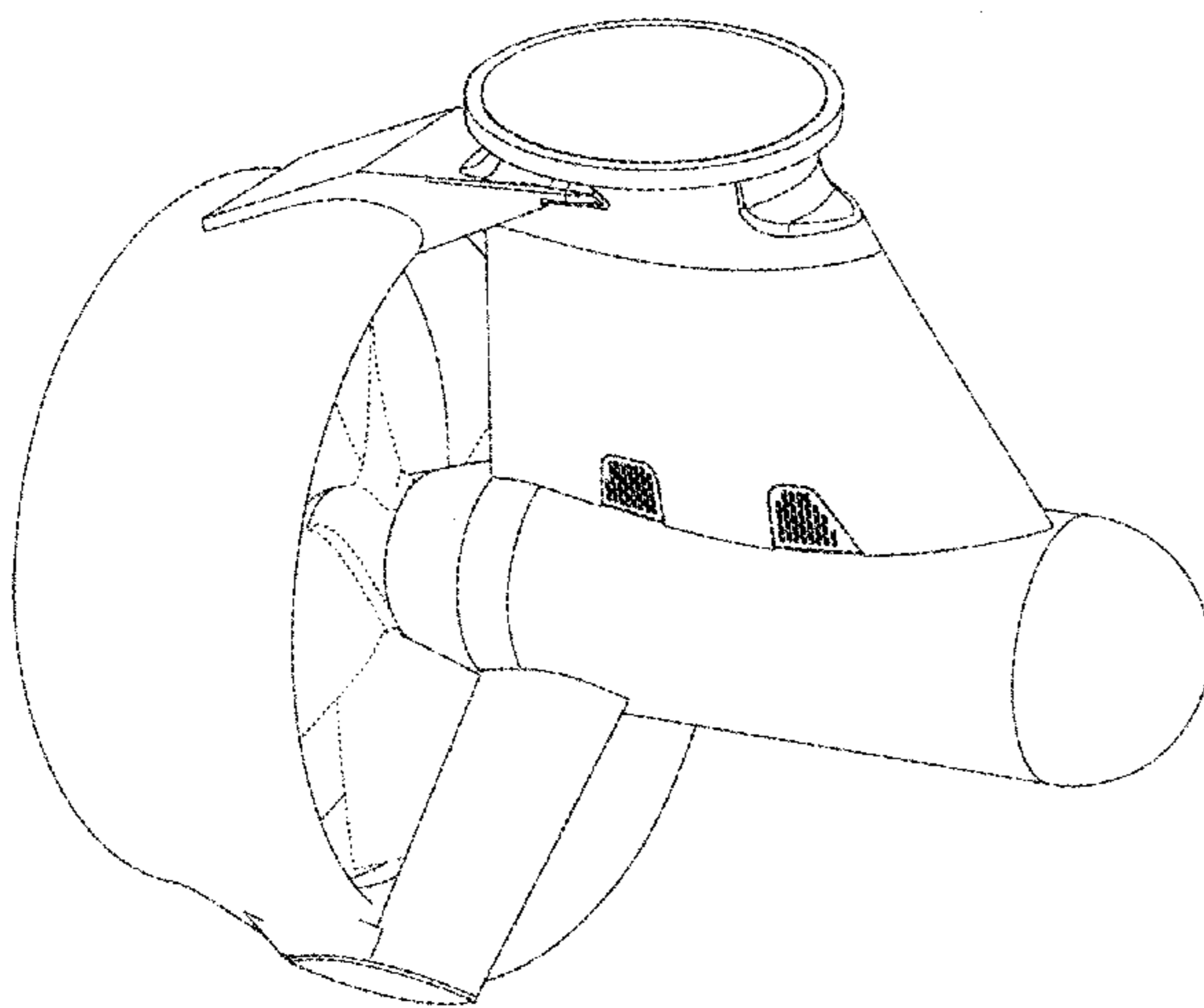

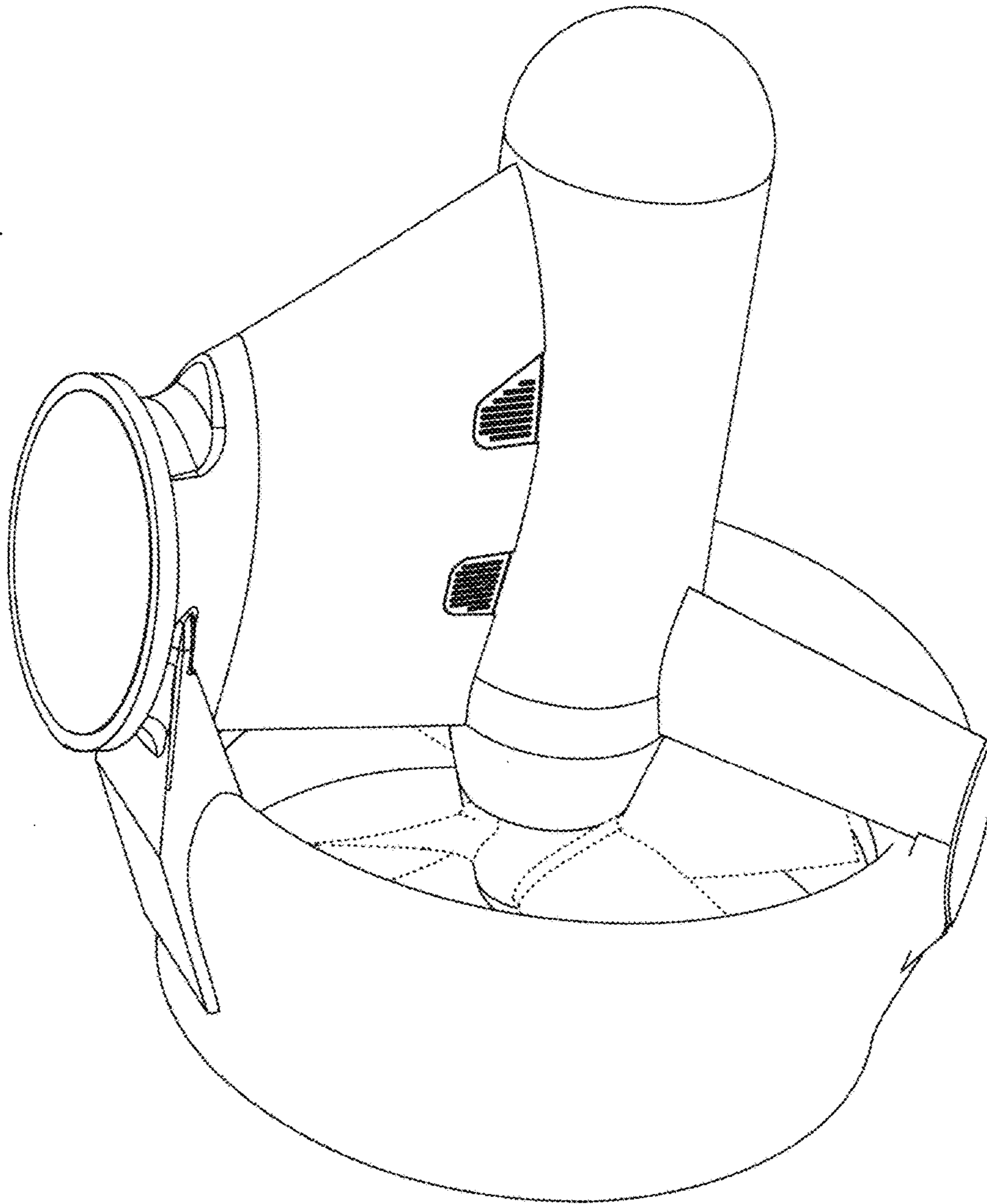

FIGURE 1

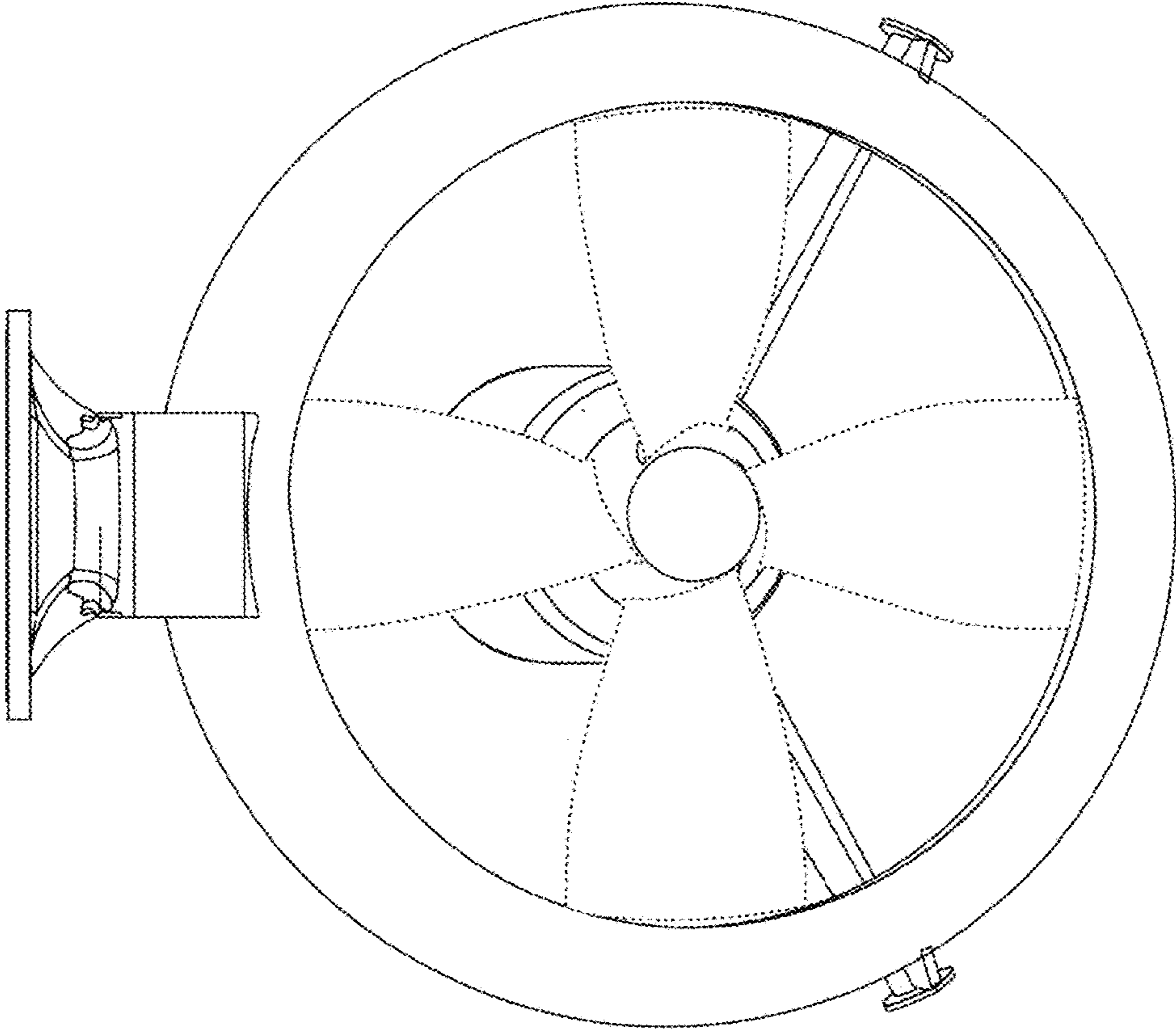

FIGURE 2

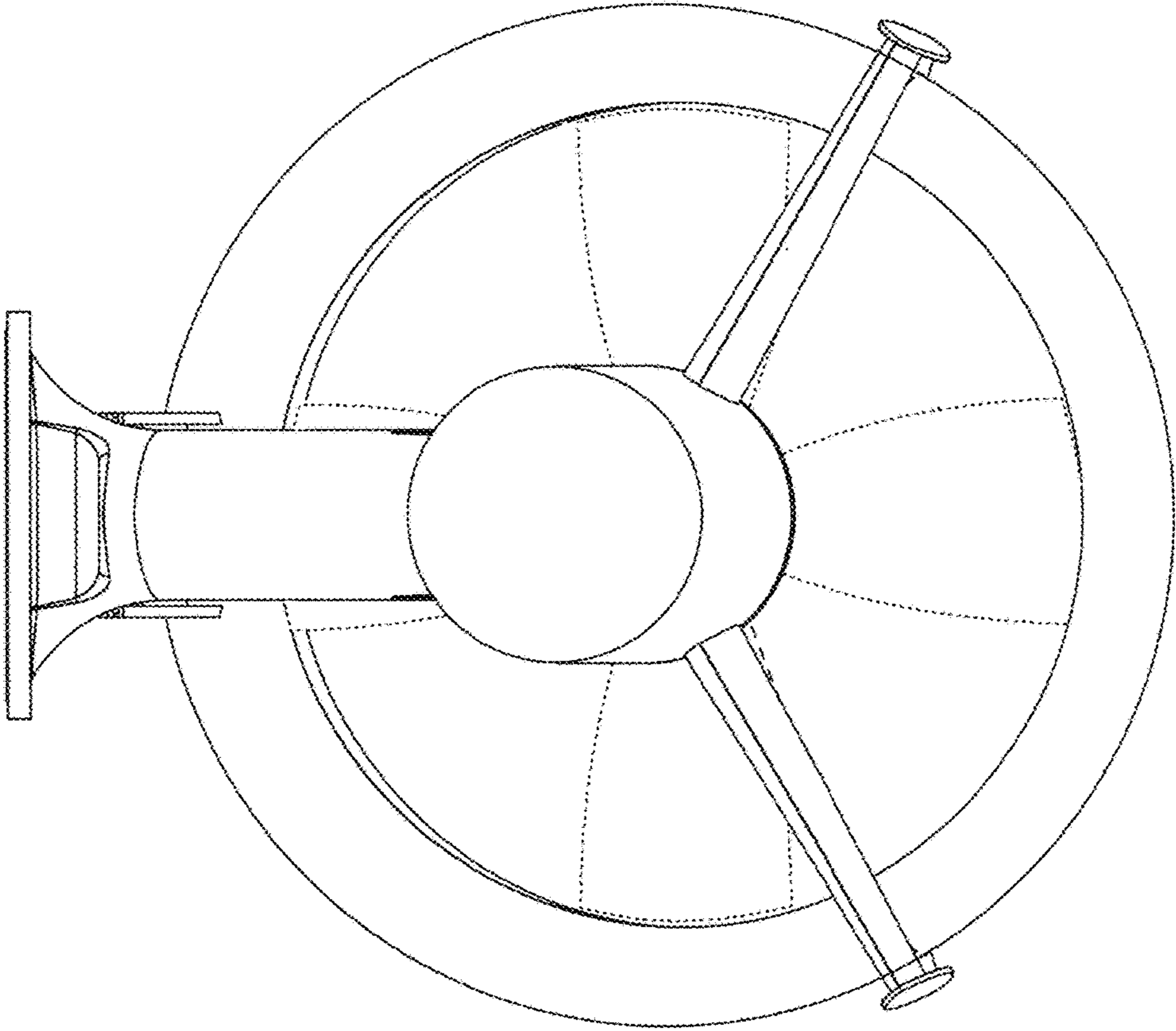

FIGURE 3

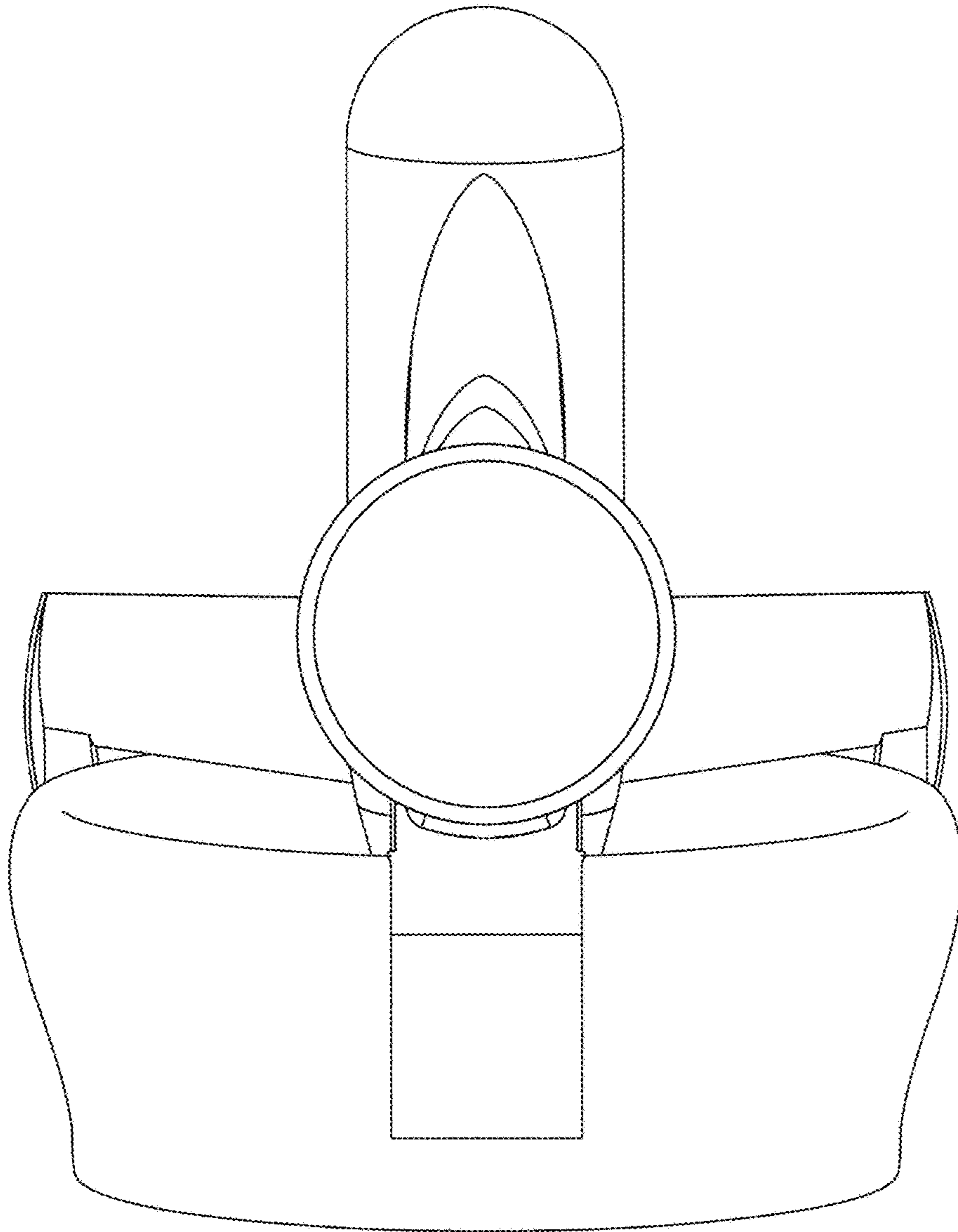

FIGURE 4

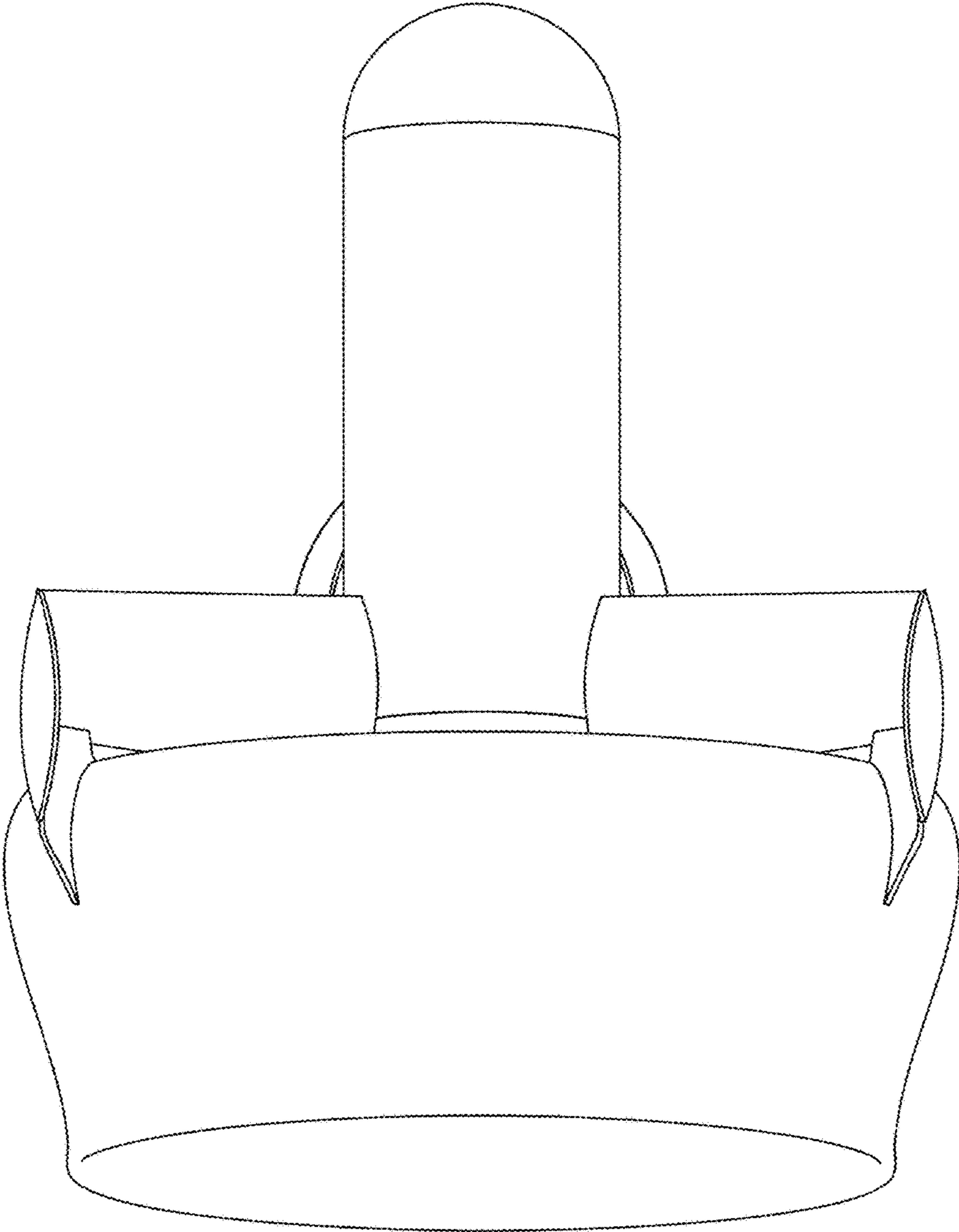

FIGURE 5

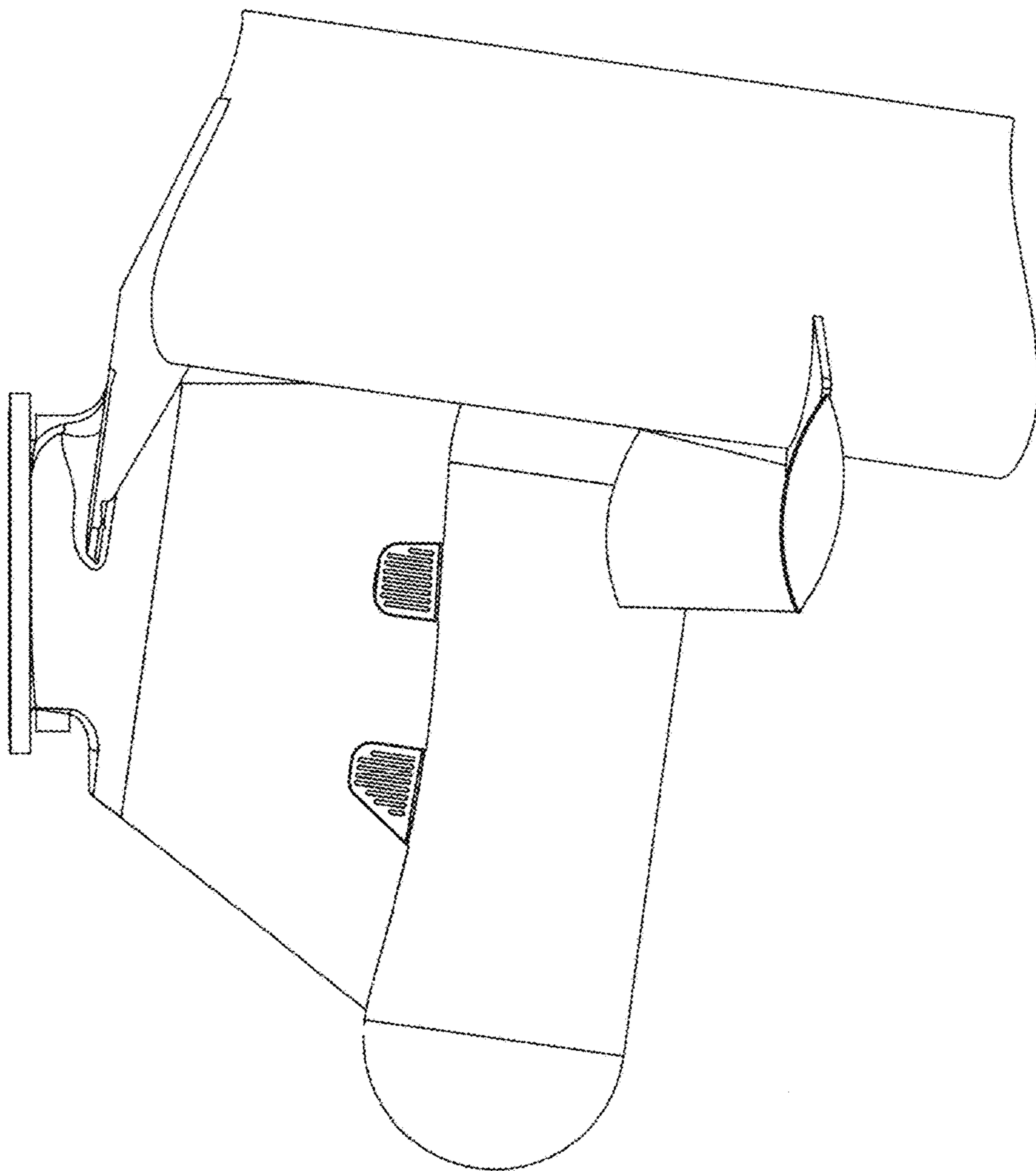

FIGURE 6

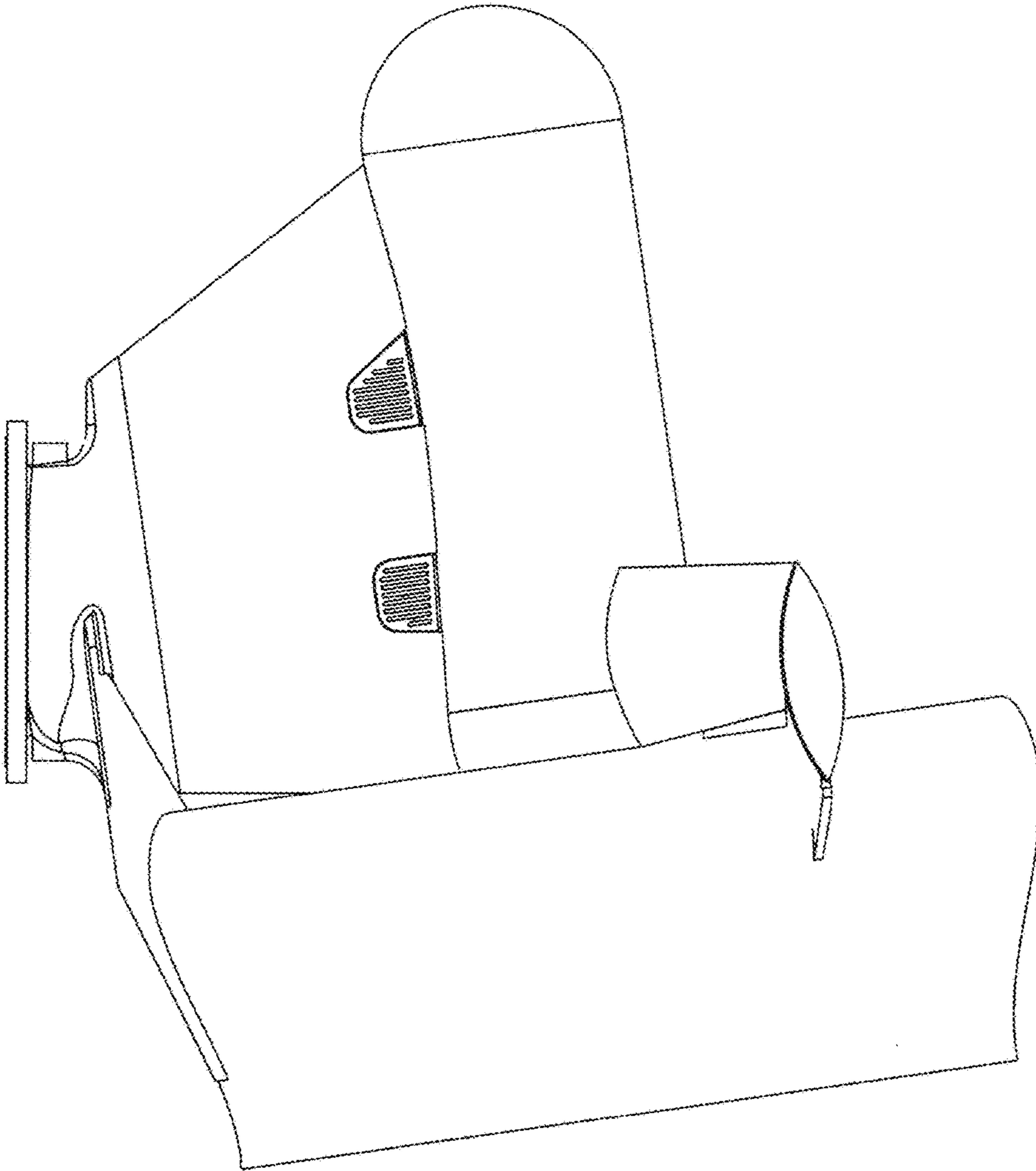

FIGURE 7