



US00D847074S

(12) **United States Design Patent**  
**Battams**

(10) **Patent No.:** **US D847,074 S**

(45) **Date of Patent:** **\*\* Apr. 30, 2019**

(54) **WHEEL**

(71) Applicant: **Jaguar Land Rover Limited**, Whitley,  
Coventry (GB)

(72) Inventor: **Robert Battams**, Whitley (GB)

(73) Assignee: **Jaguar Land Rover Limited**, Whitley,  
Coventry (GB)

(\*\*) Term: **15 Years**

(21) Appl. No.: **29/622,446**

(22) Filed: **Oct. 17, 2017**

(30) **Foreign Application Priority Data**

Apr. 21, 2017 (EM) ..... 003867100

(51) **LOC (11) Cl.** ..... **12-16**

(52) **U.S. Cl.**  
USPC ..... **D12/211**

(58) **Field of Classification Search**

USPC ..... D12/204–213

CPC .... B60B 7/00; B60B 7/02; B60B 7/04; B60B  
7/01; B60B 7/06; B60B 3/04; B60B 1/00;  
B60B 3/10; B60B 1/10; B60B 1/08;  
B60B 3/06; B60B 1/12; B60B 3/02

See application file for complete search history.

(56) **References Cited**

**U.S. PATENT DOCUMENTS**

D682,176 S \* 5/2013 Badstuebner ..... D12/209  
D686,133 S \* 7/2013 Juergens ..... D12/209  
D695,190 S \* 12/2013 Goto ..... D12/209  
D695,191 S \* 12/2013 Kogawa ..... D12/209

D740,197 S \* 10/2015 Valencia Pollex ..... D12/209  
D769,165 S \* 10/2016 Choi ..... D12/209  
D781,761 S \* 3/2017 Lee ..... D12/209  
D783,491 S \* 4/2017 Valencia Pollex ..... D12/209  
D790,426 S \* 6/2017 Valencia Pollex ..... D12/209  
D791,046 S \* 7/2017 Ishii ..... D12/209  
D792,305 S \* 7/2017 Terui ..... D12/209  
D795,778 S \* 8/2017 Valencia Pollex ..... D12/211  
D803,131 S \* 11/2017 Bridan ..... D12/209  
D818,926 S \* 5/2018 Miyazawa ..... D12/209  
D827,545 S \* 9/2018 Kawaguchi ..... D12/209  
D828,269 S \* 9/2018 Kikuchi ..... D12/209

\* cited by examiner

*Primary Examiner* — Stacia A Cadmus

(74) *Attorney, Agent, or Firm* — Wood Herron & Evans  
LLP

(57) **CLAIM**

The ornamental design for a wheel, as shown and described.

**DESCRIPTION**

FIG. 1 is a front left perspective view of a wheel for a vehicle according to the present invention.

FIG. 2 is a front view of the wheel shown in FIG. 1; and, FIG. 3 is a side left view thereof, the right side being a mirror image thereof.

In FIGS. 1-3, the broken line showing of the rear of the rim, the bolt holes, and the center hole in the central hub area is included for the purpose of illustrating environment and forms no part of the claimed design.

In FIGS. 1-3, the broken lines show environmental structure and form no part of the claimed invention. More specifically, in FIGS. 1 and 2, the centrally located broken lines show wheel hub structure, including bolt holes.

**1 Claim, 2 Drawing Sheets**

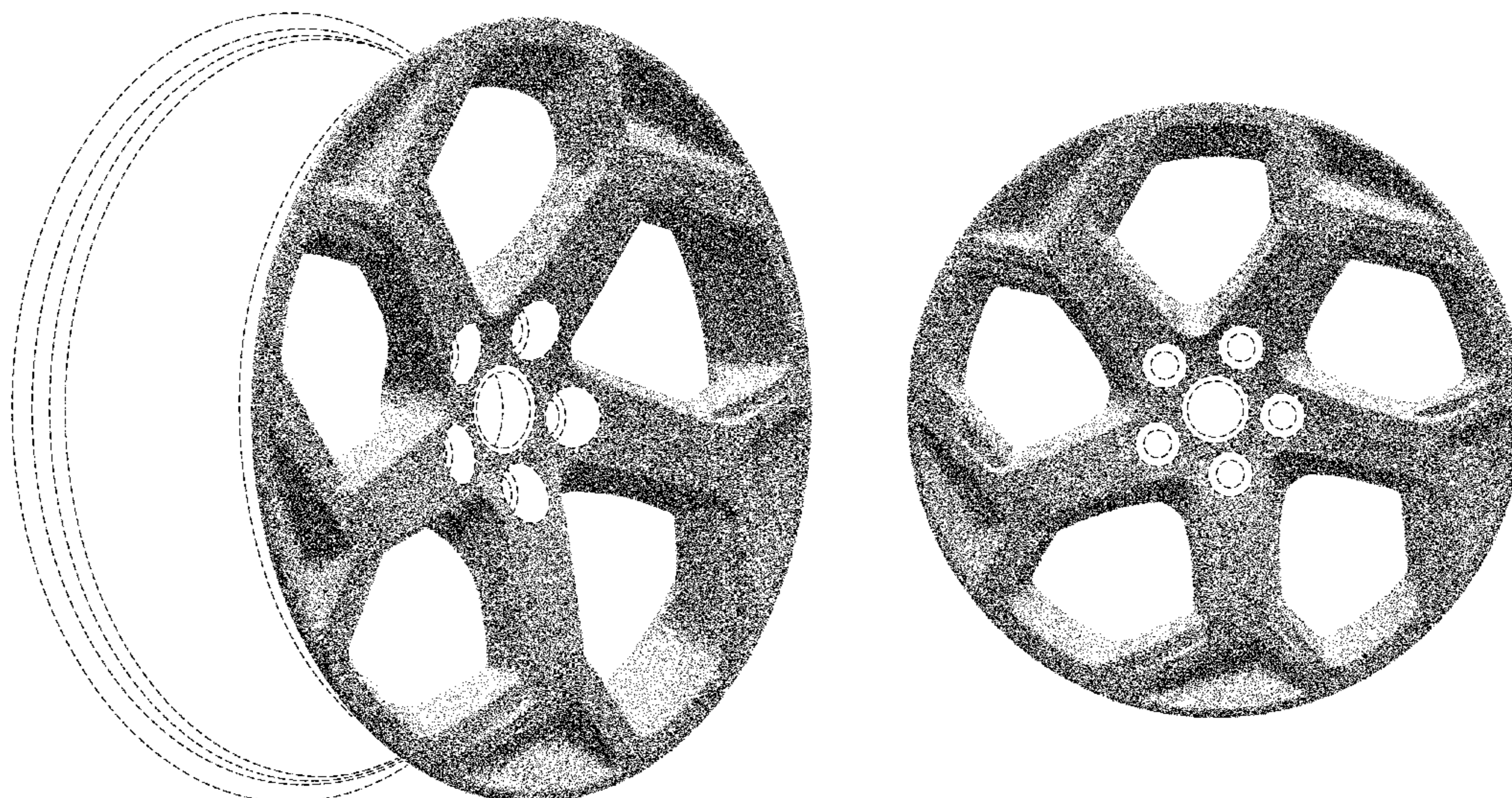



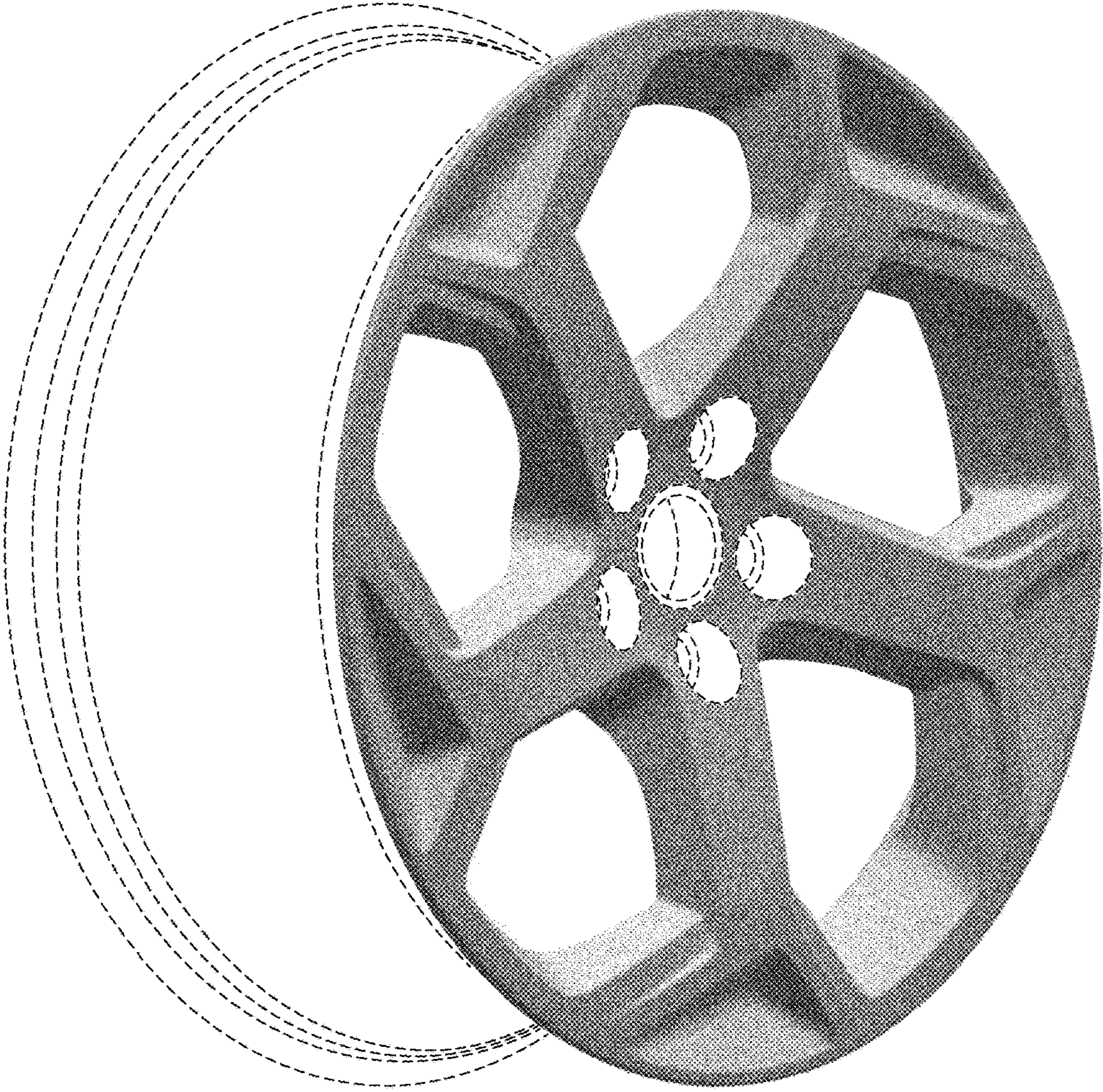

FIG. 1



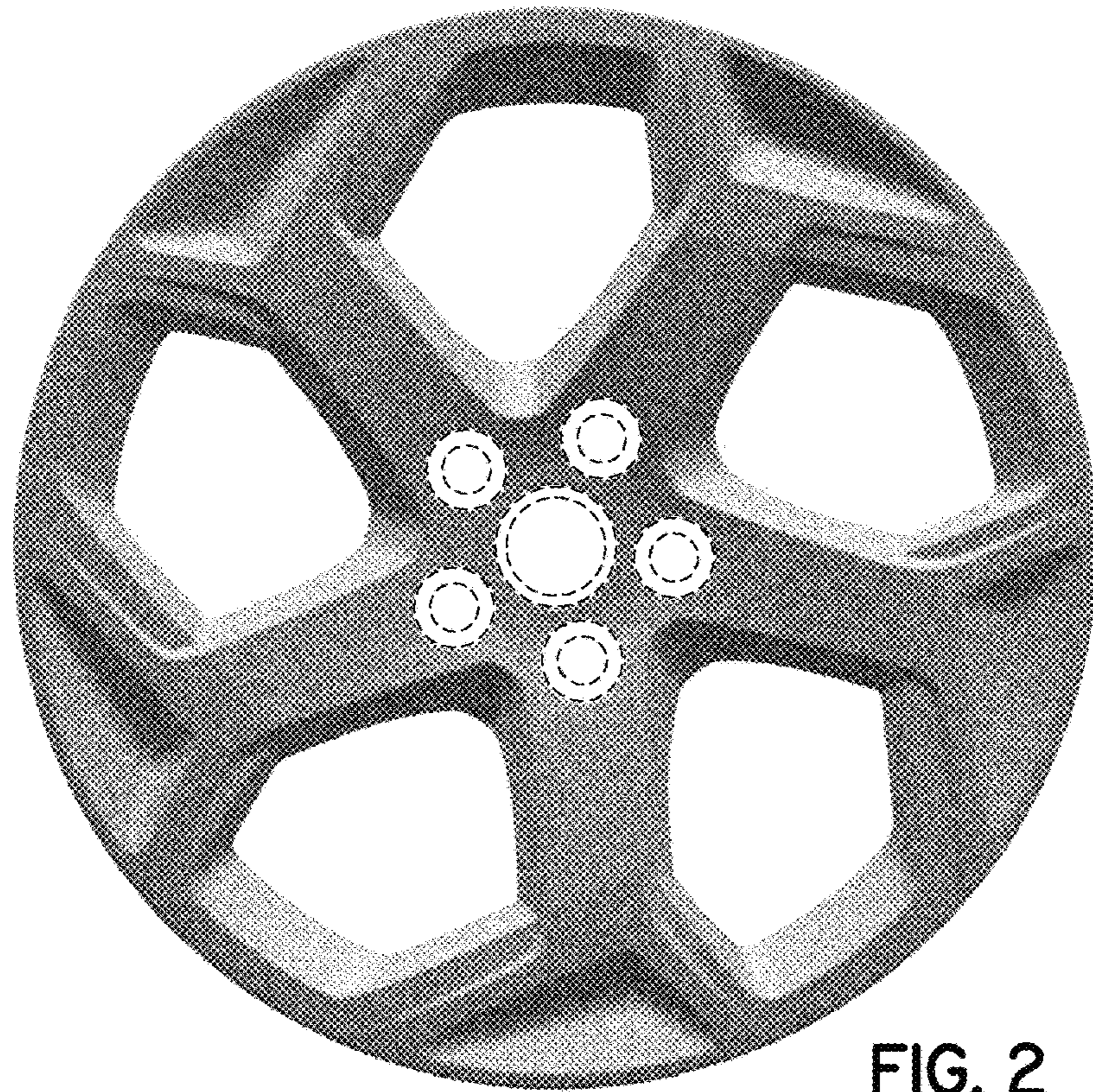

FIG. 2

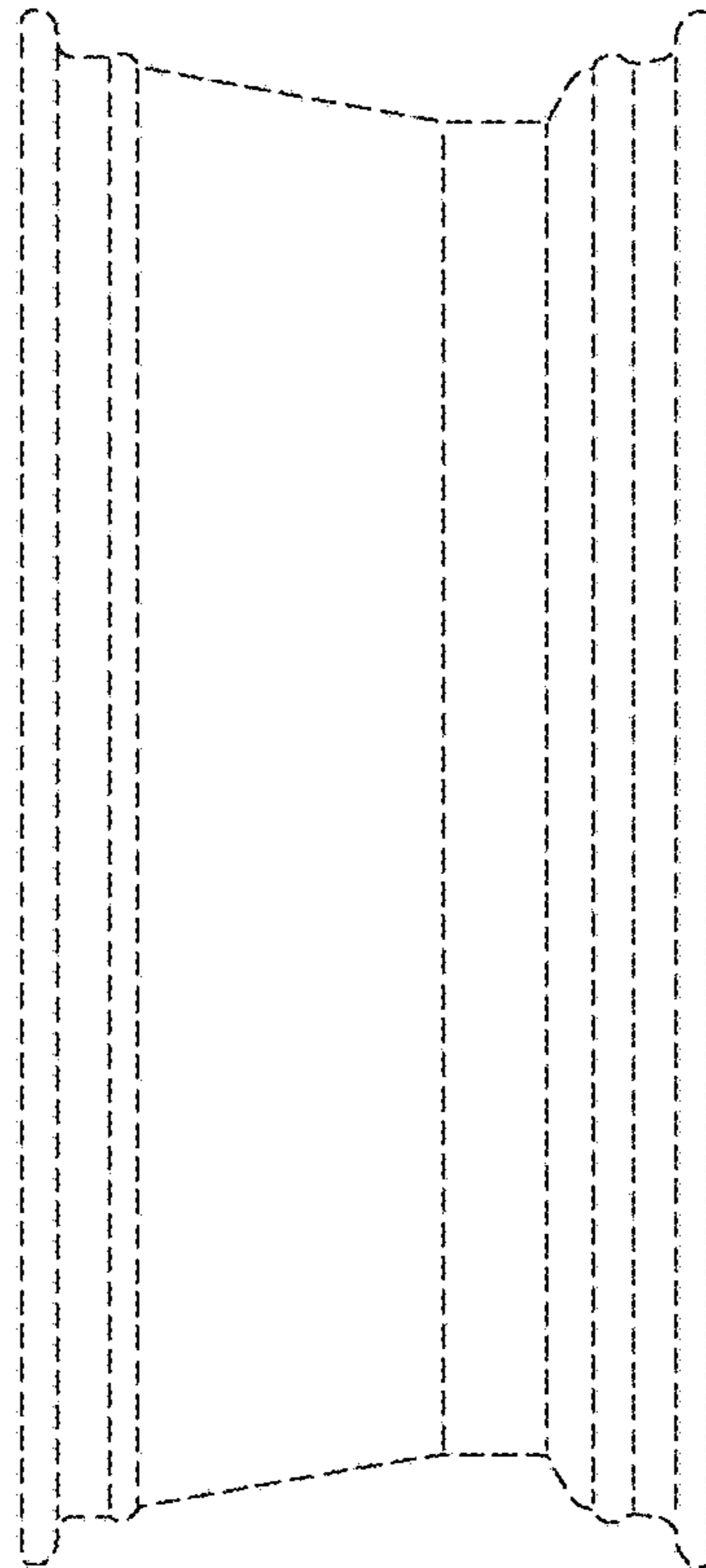

FIG. 3



UNITED STATES PATENT AND TRADEMARK OFFICE  
**CERTIFICATE OF CORRECTION**

PATENT NO. : D847,074 S  
APPLICATION NO. : 29/622446  
DATED : April 30, 2019  
INVENTOR(S) : Robert Battams

Page 1 of 1

It is certified that error appears in the above-identified patent and that said Letters Patent is hereby corrected as shown below:

On the Title Page

Column 2, Under "Description":  
Delete the entire last paragraph.

Signed and Sealed this  
Second Day of July, 2019

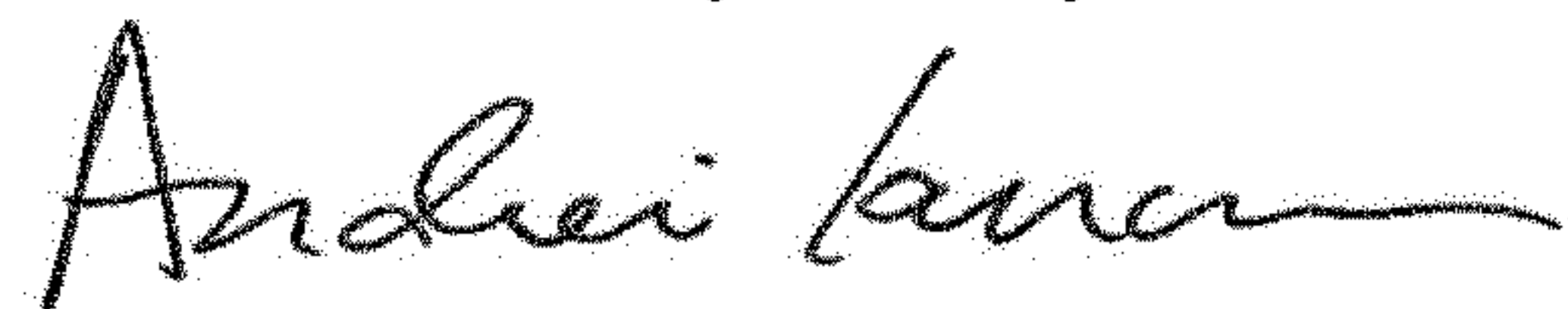

Andrei Iancu  
*Director of the United States Patent and Trademark Office*