



US00D847049S

(12) **United States Design Patent**
Munsell

(10) **Patent No.:** **US D847,049 S**

(45) **Date of Patent:** **** Apr. 30, 2019**

(54) **REAR BUMPER**

(71) Applicant: **Michael A. Munsell**, Lake Jackson, TX
(US)

(72) Inventor: **Michael A. Munsell**, Lake Jackson, TX
(US)

(**) Term: **15 Years**

(21) Appl. No.: **29/630,582**

(22) Filed: **Dec. 21, 2017**

(51) **LOC (11) Cl.** **12-16**

(52) **U.S. Cl.**
USPC **D12/169**

(58) **Field of Classification Search**
USPC D12/169, 196, 86, 90-92, 88; 293/102,
293/113, 115, 117, 120; 296/180.1, 180.2
CPC B60R 19/02; B60R 19/04; B62D 25/08
See application file for complete search history.

(56) **References Cited**

U.S. PATENT DOCUMENTS

D705,140 S * 5/2014 Kawasaki D12/169
D738,271 S * 9/2015 Glover D12/169

D768,035 S * 10/2016 Goto D12/88
D781,748 S * 3/2017 Manzoni D12/88
D788,642 S * 6/2017 Manzoni D12/88
D807,799 S * 1/2018 Kimura D12/169
D819,523 S * 6/2018 Yamamoto D12/169
D824,301 S * 7/2018 Lim D12/169
D826,089 S * 8/2018 Lesnik D12/88

* cited by examiner

Primary Examiner — Melody N Brown
(74) *Attorney, Agent, or Firm* — Dunlap Bennett &
Ludwig PLLC

(57) **CLAIM**

The ornamental design for a rear bumper, as shown and described.

DESCRIPTION

FIG. 1 is a front perspective view of a rear bumper, showing my new design;
FIG. 2 is a front elevation view thereof;
FIG. 3 is a rear elevation view thereof;
FIG. 4 is a left side elevation view thereof, the right side elevation view being a mirror image of FIG. 4;
FIG. 5 is a top plan view thereof; and,
FIG. 6 is a bottom plan view thereof.
The broken lines shown in the drawings depict portions of the rear bumper that form no part of the claimed design.

1 Claim, 6 Drawing Sheets

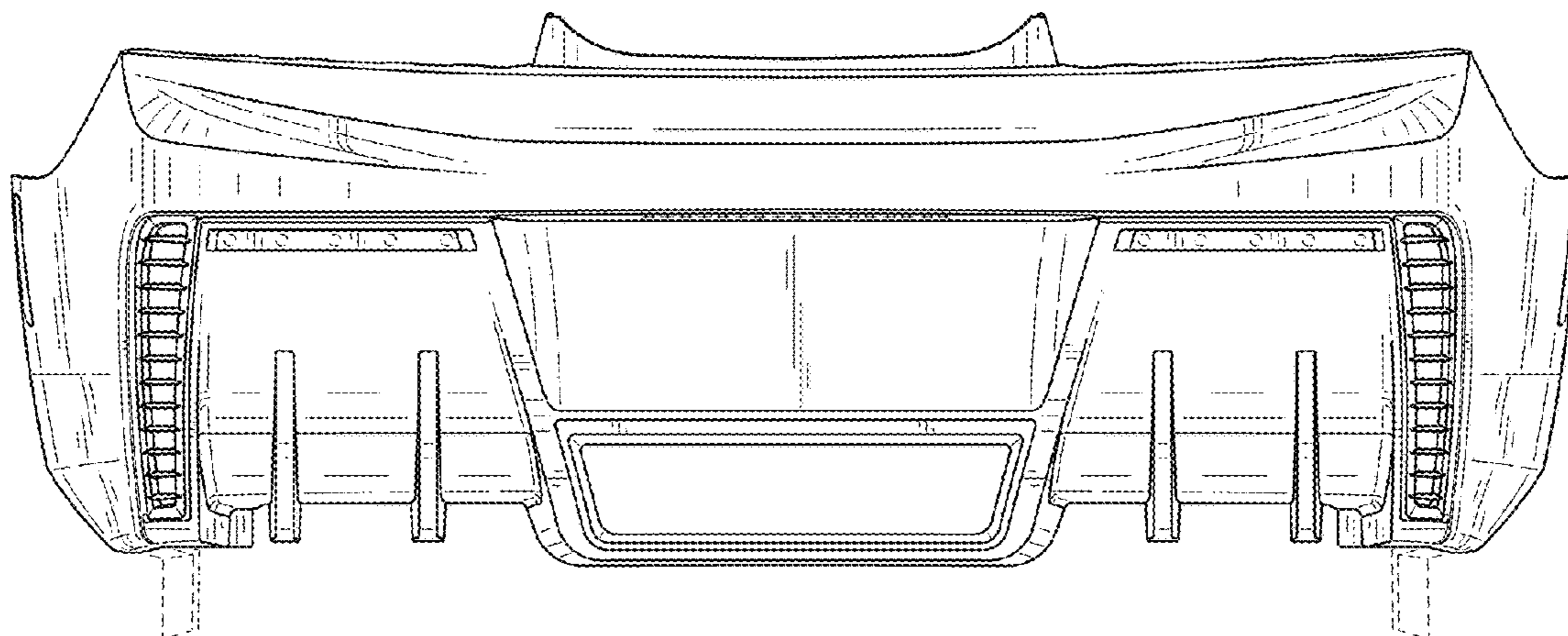

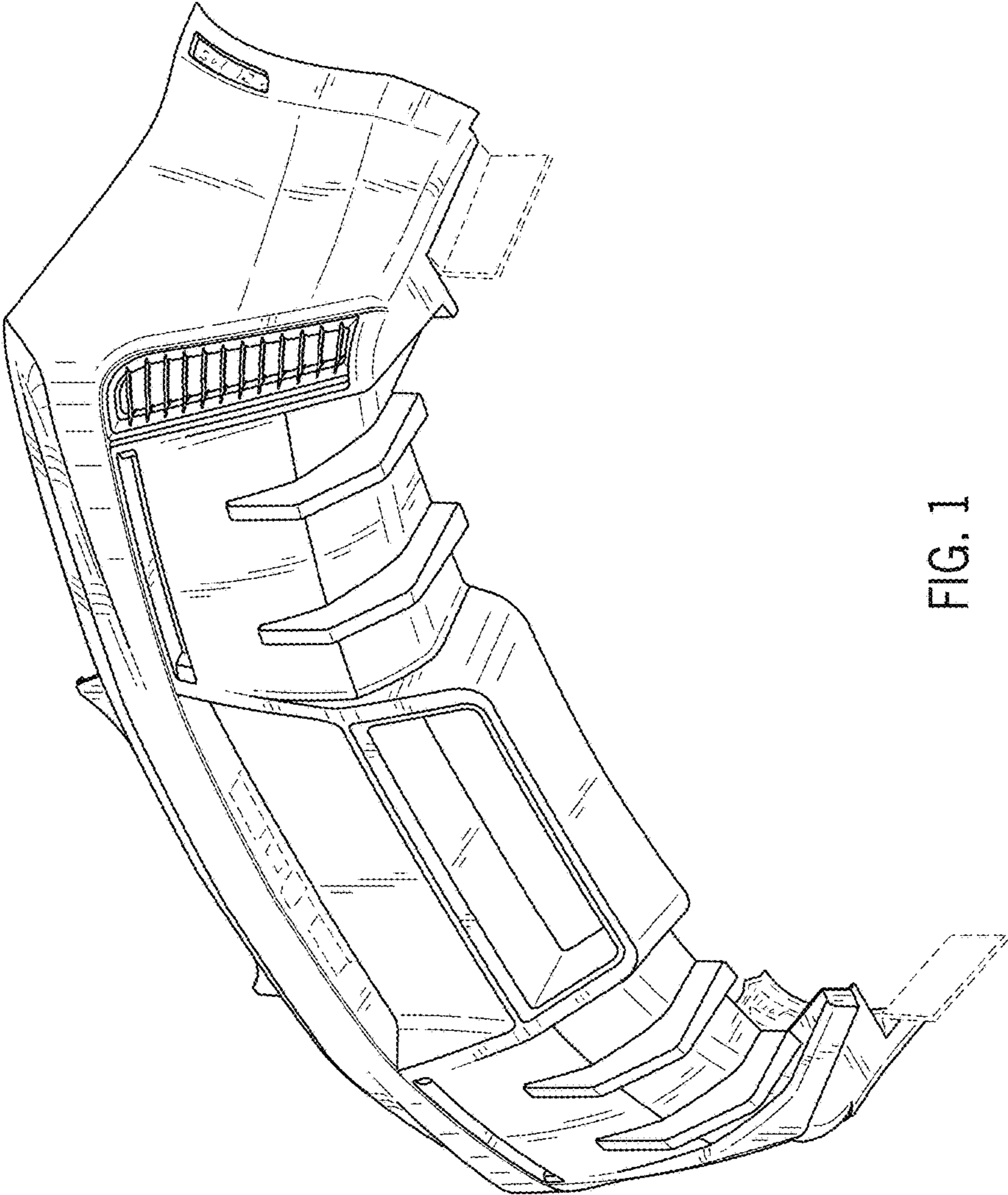

FIG. 1

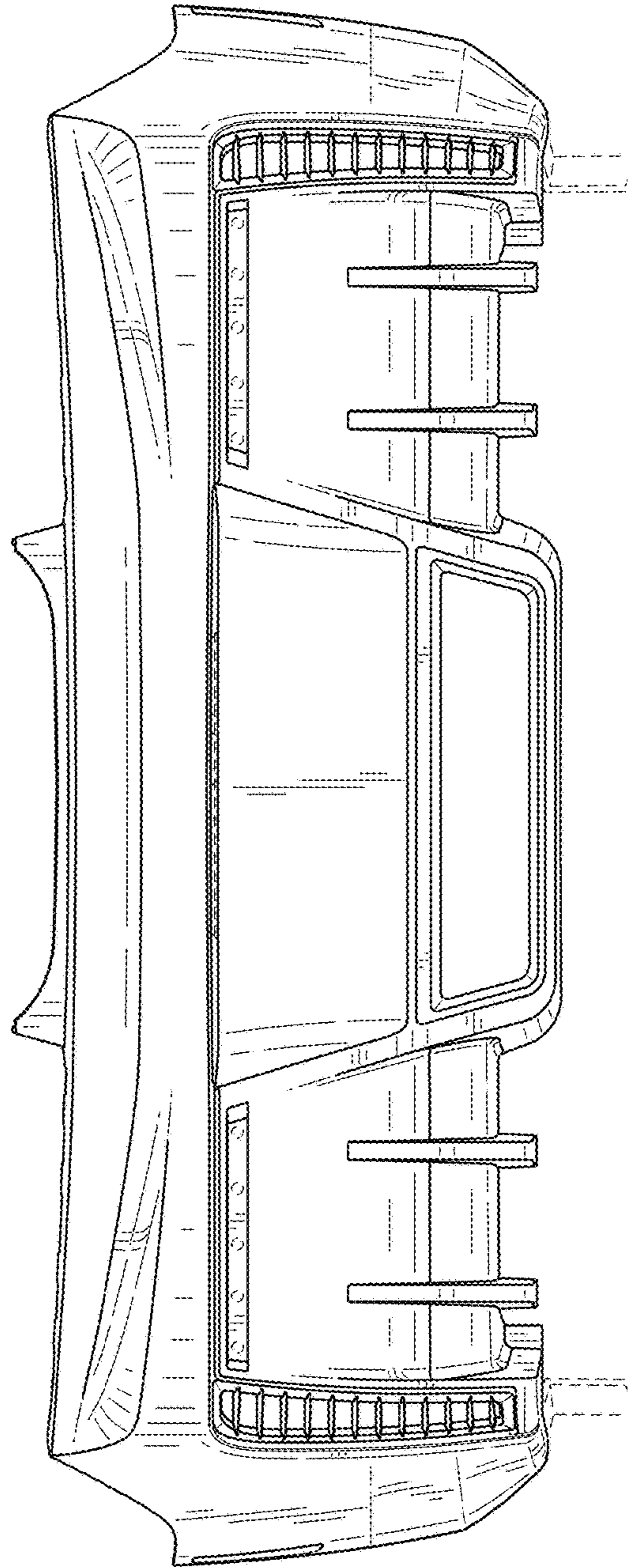

FIG. 2

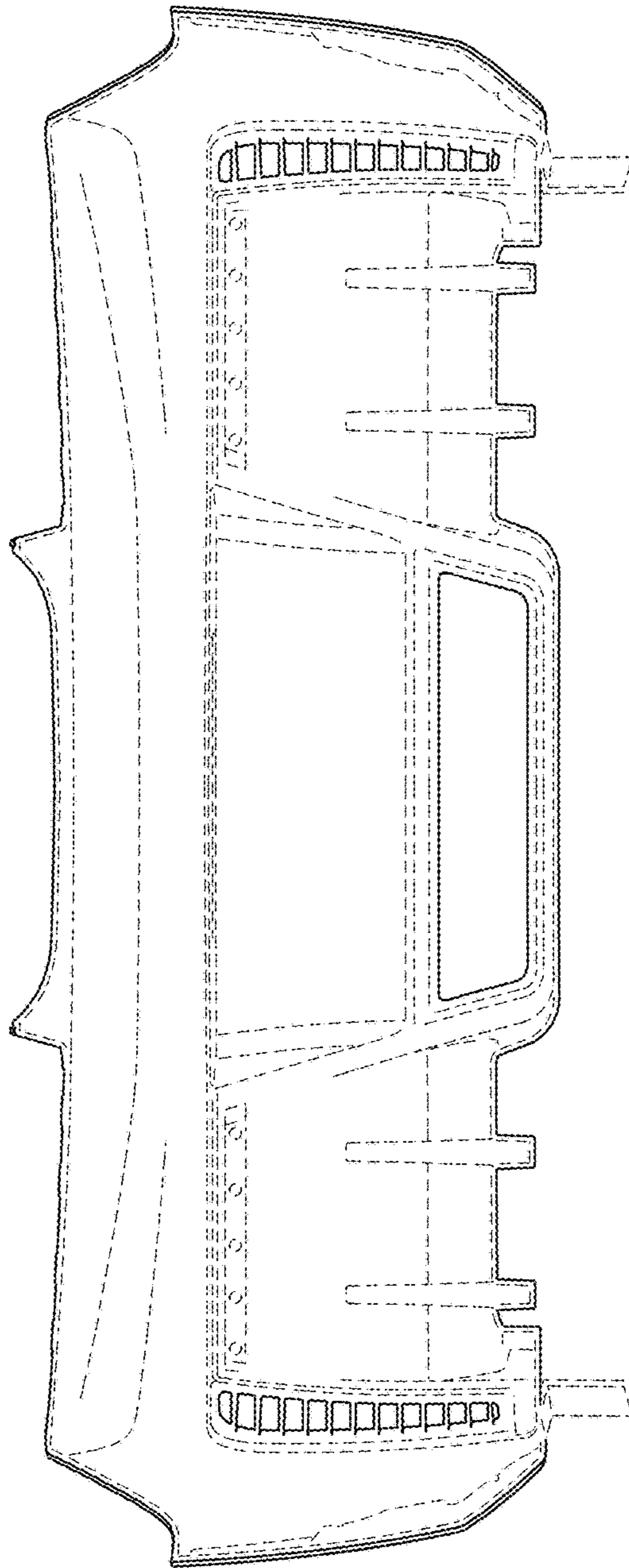

FIG. 3

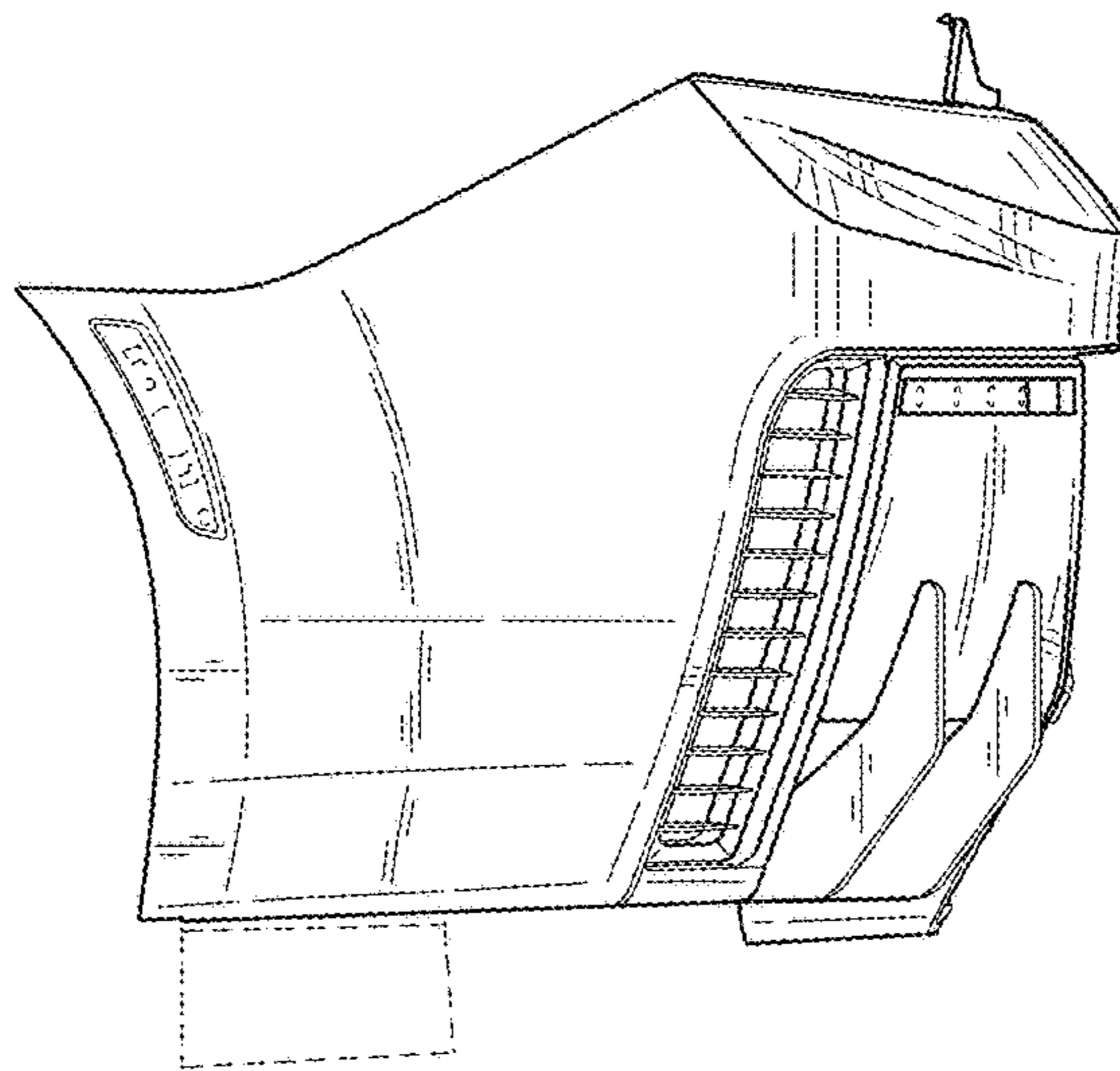

FIG. 4

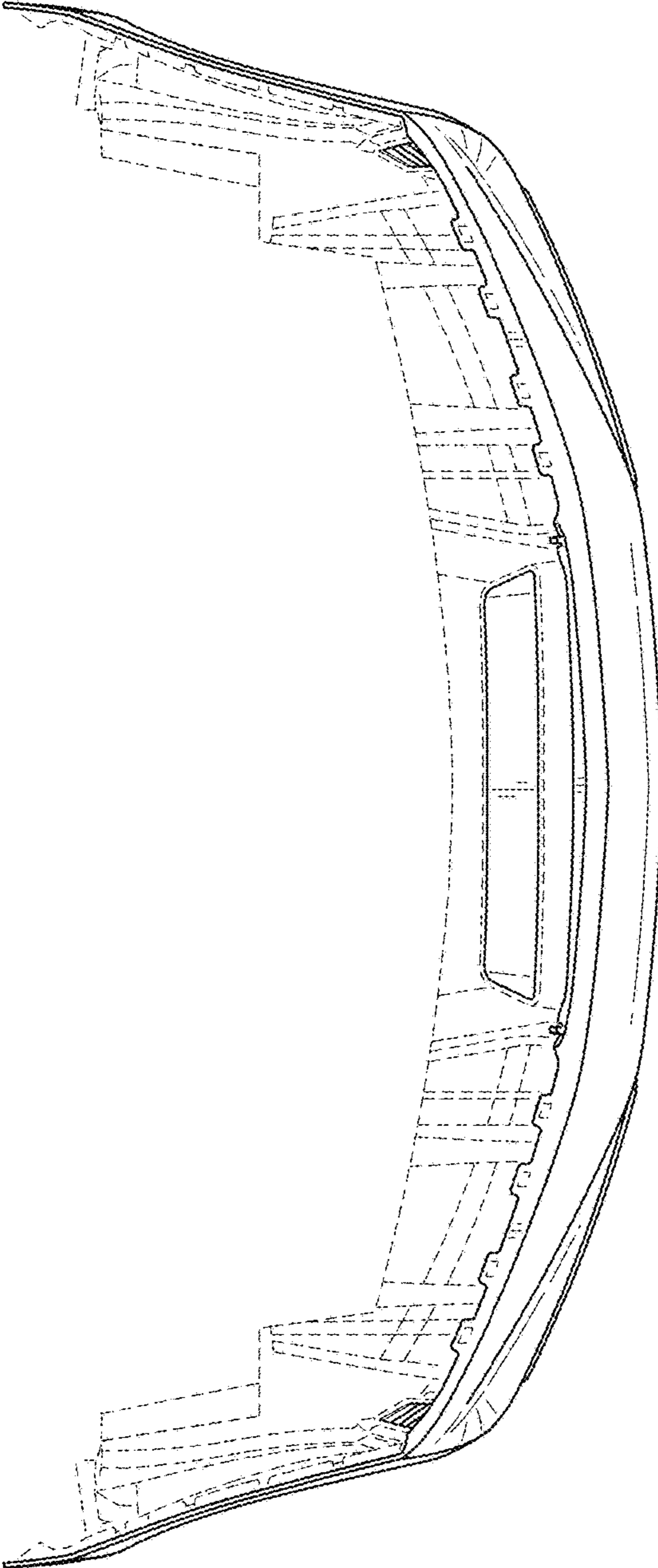

FIG. 5

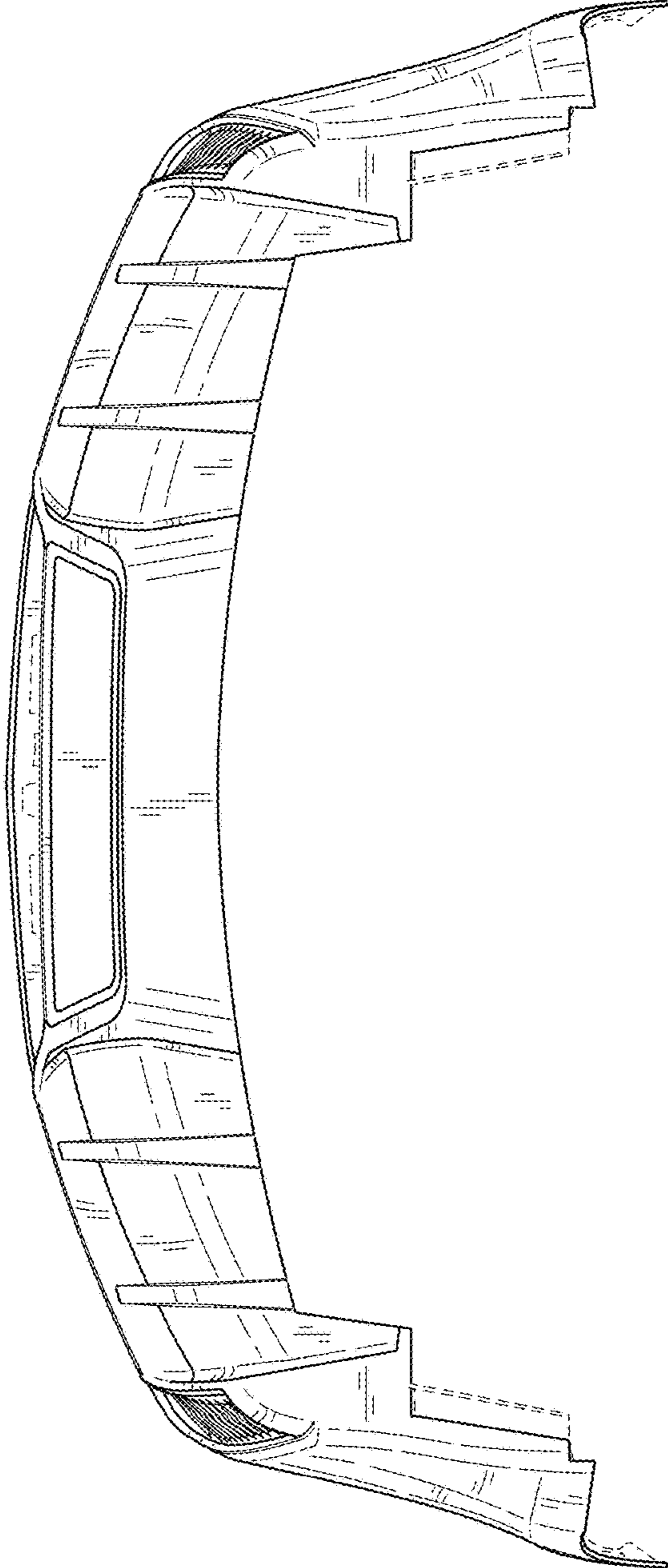

FIG. 6