



US00D846849S

(12) **United States Design Patent** (10) **Patent No.:** **US D846,849 S**  
**Gavrieli et al.** (45) **Date of Patent:** **\*\* Apr. 30, 2019**

(54) **BALLET SHOE** 1,208,209 A 12/1916 Prince  
 1,214,666 A 2/1917 Ford  
 (71) Applicant: **Gavrieli Brands LLC**, Beverly Hills, CA (US) 1,519,009 A 12/1924 Reina  
 1,525,848 A \* 2/1925 Bonaventure ..... A43B 5/12  
 36/113  
 (72) Inventors: **Kfir Gavrieli**, Beverly Hills, CA (US); 1,587,377 A 6/1926 Grosjean  
**Dikla Gavrieli**, Beverly Hills, CA (US) 1,650,466 A 11/1927 Righter  
 2,224,590 A 12/1940 Boivin  
 2,268,777 A 1/1942 Scholl  
 (73) Assignee: **Gavrieli Brands LLC**, Beverly Hills, CA (US) D133,819 S \* 9/1942 Harris ..... D2/939  
 D135,791 S 6/1943 Beebe  
 2,323,563 A 7/1943 Nugent  
 2,342,882 A 2/1944 Meltzer  
 (\*\*) Term: **15 Years** D141,871 S 7/1945 Braun  
 2,383,585 A 8/1945 Bindner  
 (21) Appl. No.: **29/663,699** D149,685 S \* 5/1948 Sandler ..... D2/935  
 D150,729 S \* 8/1948 Sandler ..... D2/923  
 (22) Filed: **Sep. 18, 2018** D166,090 S \* 3/1952 Maling ..... D2/897  
 2,772,488 A 12/1956 Meltzer  
 2,904,814 A 9/1959 Scholl  
 3,148,378 A 9/1964 Tibbitts  
 D200,897 S \* 4/1965 Mitchell ..... D2/919  
 D220,464 S 4/1971 Hayashi  
 D247,396 S \* 3/1978 Schlerth ..... D2/939  
 4,412,393 A 11/1983 Terlizzi, Jr. et al.  
 D275,525 S 9/1984 Nakao  
 4,674,206 A 6/1987 Lyden  
 D295,692 S \* 5/1988 Zuidema ..... D2/950  
 D300,085 S 3/1989 Ito et al.  
 RE33,018 E 8/1989 Ostrander  
 4,899,412 A 2/1990 Ganon  
 D316,773 S 5/1991 Valle  
 5,012,541 A 5/1991 Ganon  
 D339,669 S \* 9/1993 Miller ..... D2/919  
 5,282,326 A 2/1994 Schroer, Jr. et al.  
 5,421,050 A 6/1995 Laganas  
 5,699,629 A 12/1997 Munschy  
 5,746,014 A 5/1998 Tanemoto  
 D420,785 S 2/2000 Perez  
 6,055,745 A 5/2000 Endoh  
 6,076,284 A 6/2000 Terlizzi  
 6,189,239 B1 2/2001 Gasparovic et al.  
 6,338,207 B1 1/2002 Chang  
 D457,292 S \* 5/2002 Sessa ..... D2/949  
 D461,947 S 8/2002 Merceron  
 6,588,124 B2 6/2003 Morrone  
 D476,798 S 7/2003 Reynolds et al.  
 D498,041 S 11/2004 McClaskie  
 D500,191 S \* 12/2004 Belley ..... D2/969  
 D501,706 S 2/2005 McClaskie  
 6,857,203 B2 2/2005 Minden  
 6,895,693 B2 5/2005 Baruck  
 6,978,557 B2 12/2005 Lee

**Related U.S. Application Data**

(63) Continuation of application No. 29/595,514, filed on Feb. 28, 2017, which is a continuation of application No. 29/509,246, filed on Nov. 14, 2014, now Pat. No. Des. 781,032, which is a continuation of application No. 14/266,599, filed on Apr. 30, 2014, now Pat. No. 9,398,786, which is a continuation of application No. 13/207,397, filed on Aug. 10, 2011, now Pat. No. 8,745,893.

(51) **LOC (11) Cl.** ..... **02-04**  
 (52) **U.S. Cl.**  
 USPC ..... **D2/939**  
 (58) **Field of Classification Search**  
 USPC ..... D2/896, 900, 919-921, 925, 939, 947, D2/950, 969, 971  
 CPC ..... A43B 21/00; A43B 21/02; A43B 21/06; A43B 9/14; A43B 1/0045; A43B 13/10; A43B 13/12; A43B 23/06; A43B 23/07; A43B 1/0036; A43B 5/12  
 See application file for complete search history.

(56) **References Cited**

**U.S. PATENT DOCUMENTS**

249,086 A 11/1881 Pienovi  
 773,850 A 11/1904 Cooper et al.  
 830,941 A 9/1906 Walden

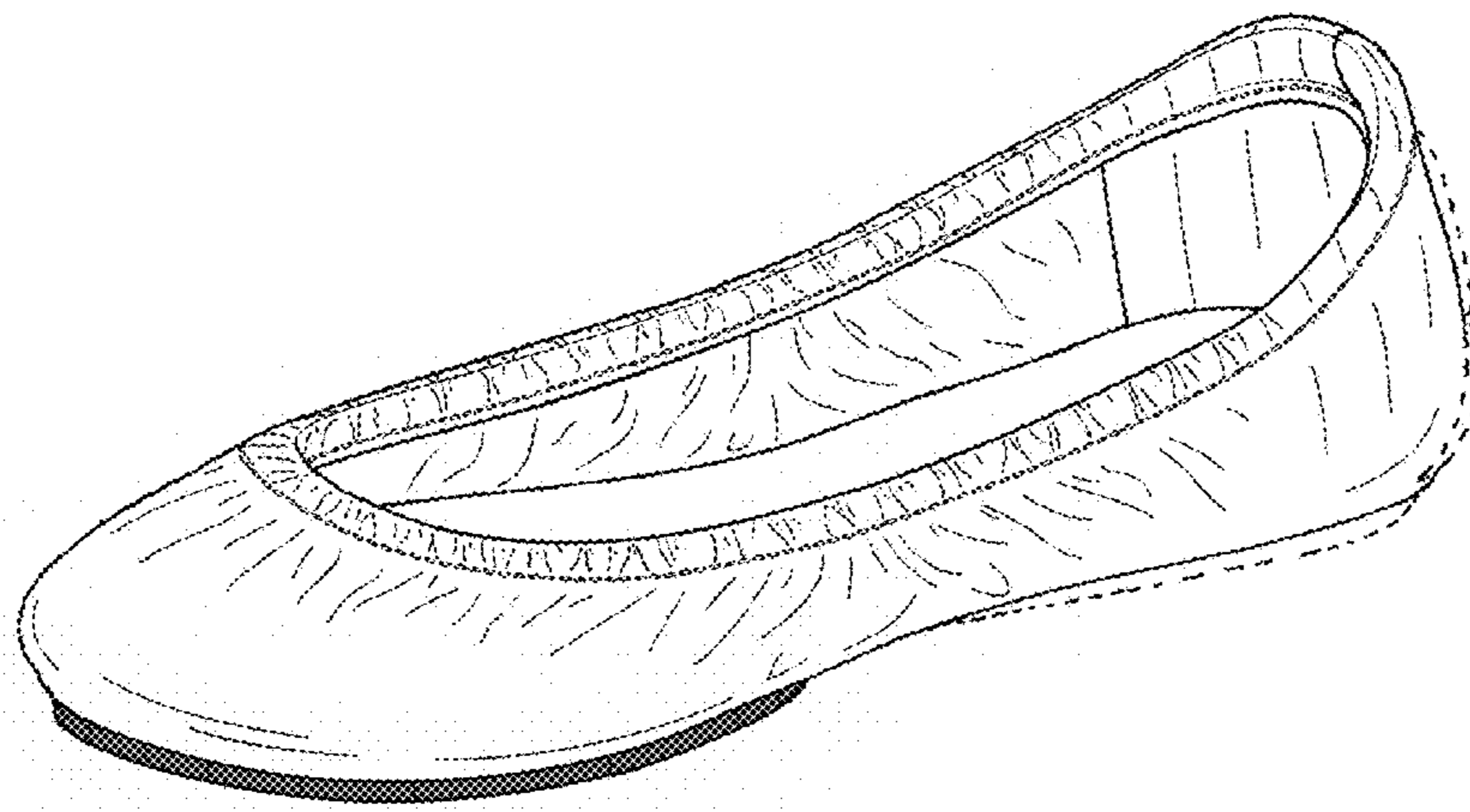

# US D846,849 S

Page 2

7,032,327 B1	4/2006	Tartaglia et al.	D689,272 S *	9/2013	Gavrieli	A43B 3/248
7,036,244 B1	5/2006	Finch				D2/939
D527,513 S	9/2006	Della Valle	D690,914 S *	10/2013	Gavrieli	A43B 3/248
D529,513 S *	10/2006	Aketa				D2/939
D531,790 S	11/2006	Wurzburg	D690,915 S *	10/2013	Gavrieli	A43B 3/248
D534,341 S *	1/2007	Choi				D2/939
D542,513 S	5/2007	Amado et al.	D696,500 S	12/2013	Hunt	
D556,990 S	12/2007	Cabados	D699,424 S	2/2014	Hamm	
7,337,558 B2	3/2008	Terlizzi et al.	8,661,714 B2	3/2014	Sussman	
D567,485 S	4/2008	James	8,745,893 B2 *	6/2014	Gavrieli	A43B 3/248
D570,488 S	6/2008	Kirksey et al.				36/8.3
D571,084 S	6/2008	Comeau	8,973,287 B2	3/2015	Shibata	
D571,548 S	6/2008	Seamans	9,398,786 B2 *	7/2016	Gavrieli	A43B 3/248
D571,989 S	7/2008	Siegal	D781,032 S *	3/2017	Gavrieli	A43B 3/248
D580,640 S	11/2008	Wurzburg				D2/939
D582,638 S	12/2008	Ringholz	D782,167 S *	3/2017	Gavrieli	A43B 3/248
7,496,982 B2	3/2009	Clark et al.				D2/939
7,506,459 B2	3/2009	Grisoni et al.	D831,312 S *	10/2018	Gavrieli	A43B 3/248
D591,031 S	4/2009	Cofinco				D2/939
D593,295 S *	6/2009	Belley	2002/0078591 A1	6/2002	Morrone	
D593,297 S *	6/2009	Belley	2002/0129519 A1	9/2002	Cahan	
D593,307 S *	6/2009	Belley	2003/0070319 A1	4/2003	Minden	
D599,093 S *	9/2009	Issler	2003/0121176 A1	7/2003	Baruck	
D604,030 S	11/2009	Wilson	2004/0025377 A1	2/2004	Brannon	
D607,194 S	1/2010	Zagula	2005/0022421 A1	2/2005	Bruckner	
D610,332 S	2/2010	Raichle	2005/0115115 A1	6/2005	Lacey	
D610,785 S	3/2010	Smith	2005/0217148 A1	10/2005	Connolly et al.	
D612,140 S	3/2010	Moon	2005/0262734 A1	12/2005	Cheng	
D612,141 S	3/2010	Moon	2006/0086005 A1	4/2006	Yerian	
7,694,435 B1	4/2010	Kiser et al.	2006/0156576 A1	7/2006	Sloan	
D615,737 S	5/2010	Feller	2007/0074424 A1	4/2007	Lin	
7,735,244 B1	6/2010	Ameche	2007/0204482 A1	9/2007	Gibson-Collinson	
7,743,530 B2	6/2010	Truelsen	2007/0204483 A1	9/2007	Kirsch et al.	
D618,891 S	7/2010	McClaskie	2008/0052964 A1	3/2008	Taylor	
7,757,408 B2	7/2010	McClaskie	2008/0086912 A1	4/2008	Wilkenfeld	
D630,829 S	1/2011	Weisner	2008/0110059 A1	5/2008	Kuramoto et al.	
D632,881 S	2/2011	Rosenberg	2009/0019732 A1	1/2009	Sussmann	
7,926,203 B2	4/2011	Wilkenfeld	2009/0193685 A1	8/2009	Wilson	
7,966,747 B2	6/2011	Wilkenfeld et al.	2009/0205222 A1	8/2009	Mclinden	
D640,861 S	7/2011	Wilkenfeld	2009/0272009 A1	11/2009	Weisner et al.	
8,020,320 B2	9/2011	Gillespie	2010/0011625 A1	1/2010	Percival	
8,127,468 B2	3/2012	Morgan	2010/0018080 A1	1/2010	Smith	
D657,543 S	4/2012	Bove	2010/0050469 A1	3/2010	Chen	
D659,960 S	5/2012	Bizzo	2010/0095557 A1	4/2010	Jarvis	
8,230,619 B2	7/2012	Salvatelli	2010/0115793 A1	5/2010	Kraisosky	
D664,755 S	8/2012	Gavrieli et al.	2010/0122475 A1	5/2010	Purrington	
D665,157 S	8/2012	Wu	2010/0146822 A1	6/2010	MacGregor	
8,240,067 B2	8/2012	Sussmann	2010/0212186 A1	8/2010	Cheng	
8,245,420 B2	8/2012	Wilson	2010/0275462 A1	11/2010	Pucci	
D668,027 S	10/2012	Millieret	2010/0281713 A1	11/2010	Pantazes	
D668,438 S	10/2012	Millieret	2015/0089843 A1	4/2015	Gavrieli	
D668,847 S *	10/2012	Gavrieli				D2/925
D668,848 S *	10/2012	Gavrieli				D2/925
D668,849 S	10/2012	Pozzi				
D668,850 S	10/2012	Pozzi				
D672,542 S	12/2012	Gray et al.				
D676,634 S *	2/2013	Gavrieli				D2/925
D681,927 S *	5/2013	Gavrieli				A43B 3/248
						D2/939
D681,928 S *	5/2013	Gavrieli				A43B 3/248
						D2/939
D681,929 S *	5/2013	Gavrieli				A43B 3/248
						D2/939
D683,936 S *	6/2013	Gavrieli				A43B 3/248
						D2/939
8,468,723 B2	6/2013	Malka-Harari				
D686,812 S	7/2013	Gavrieli et al.				
8,510,975 B2	8/2013	Krikelis				
D688,853 S *	9/2013	Gavrieli				A43B 3/248
						D2/939
D688,854 S *	9/2013	Gavrieli				A43B 3/248
						D2/939
D688,855 S *	9/2013	Gavrieli				A43B 3/248
						D2/939
D689,270 S *	9/2013	Gavrieli				A43B 3/248
						D2/939
D689,271 S *	9/2013	Gavrieli				A43B 3/248
						D2/939

## FOREIGN PATENT DOCUMENTS

DE	20	2006	000230	U1	5/2007
GB			2443937	A	5/2008
GB			2 446 205	A	8/2008
TW			D119165		10/2007

## OTHER PUBLICATIONS

Examination Report for AU 341324, 3 pgs., dated Oct. 24, 2012.  
Letter from TMI and Associates with Office Action, 2 pgs, dated Sep. 19, 2012 <http://www.payless.com/store/?&TLC=Womens&SLC=WomensNewArrivals&BLC=WomensNewArrivalsNewArrivals&With+Regular&ItemCode=60131&LotNumber=062642&Type=Adult&Popularity=637&Descriptvein> .  
Taiwanese Office Action for TW 101300726, 10 pgs., dated Sep. 6, 2012.  
“The Love List, Tiefs by Gavrieli—Foldable Ballet Flats,” <http://thelovelist-carly.blogspot.com.au/2010/09/tiefs-by-gavrieli-foldable-ballet.html>, 2 pgs., Sep. 12, 2010.  
“Tiefs by Gavrieli,” <http://tiefs.com>, 1 pg., retrieved Mar. 13, 2013 from URL.  
“Try It Mummy!, Tiefs by Gavrieli, ” <http://tryitmummy.blogspot.com.au/2010/12/tiefs-by-gavrieli.html>, 3 pgs., Dec. 9, 2010.

“Wearability—Real People Style, What came first, the City Flat or the Tieks,” <http://wearability.posterous.com/what-came-first-the-city-flat-or-the-tieks>, 2 pgs., Aug. 29, 2010.

“The Ballet Flat . . . Reinvented; Ballet Flats . . . with a Bonus; Step Into Tieks; Going Places? Take Tieks,” <http://web.archive.org/web/2010052004346/http://www.tieks.com/>; 4 pgs., May 24, 2010.

“Tieks—Comfortable designer flats you can fit in your purse and wear all day, every day,” <http://web.archive.org/web/20110731151555/http://tieks.com/>; 6 pgs., Jul. 31, 2011.

“58th Annual Emmy Awards,” [http://spoonsforksandfashion.blogspot.com/2006\\_08\\_01\\_archive.html](http://spoonsforksandfashion.blogspot.com/2006_08_01_archive.html), depicting Nine West flats, 2 pgs., Aug. 1, 2006.

Pictures of Nine West flats sold in 2006, 3 pgs.

“I Love a Good Ballet Flat!,” <http://dressupfiles.com/i-love-a-good-ballet-flat>, depicting Sue London flats, 3 pgs., Sep. 3, 2010.

Pictures of Sue London flats sold in 2010, 2 pgs.

“Miss Cathie Reviews: The Yosi Samra Foldable Ballet Flat . . .,” <http://www.misscathie.com/2010/01/miss-cathie-reviews-the-yosi-samra-foldable-ballet-flat/>, depicting Yosi Samra flats, 9 pgs., Jan. 2010.

Pictures of Yosi Samra flats sold in 2010, 2 pgs.

“Goodbye two thousand ten,” [http://emmajoyrussell.blogspot.com/2010\\_12\\_01\\_archive.html](http://emmajoyrussell.blogspot.com/2010_12_01_archive.html), depicting Gap flats, 39 pgs., Dec. 1, 2010.

Pictures of Gap flats available for sale in 2010, 9 pgs.

“Our newest design of folding flats-Pink,” <https://fitinclouds.wordpress.com/2010/05/16/our-newest-design-of-folding-flats-pink/>, depicting Fit in Clouds flats, 1 pg., May 16, 2010.

“Fit in Clouds Satin Folding Shoes,” <http://www.goodhousekeeping.com/product-reviews/clothing/best-ballet-flats/fit-in-clouds-satin-foldable-ballet-flats>, depicting Fit in Clouds flats, 2 pg., Aug. 2013.

Pictures of Fit in Clouds flats available for sale in 2011, 4 pgs.

“Shoes for Standing,” <https://truthinshoes.wordpress.com/2008/07/>, depicting Sam & Libby flats, 2 pgs., Jul. 31, 2008.

“Target Designer Collaboration: Announcing Sam & Libby Shoes for Target,” <http://www.therecessionista.com/2012/11/target-designer-collaboration-announcing-sam-libby-shoes-for-target.html>, depicting Sam & Libby flats, 1 pg., Nov. 26, 2012.

Pictures of Sam & Libby flats available for purchase in 2011, 5 pgs.

“Save your soles with Citisoles ballet flats,” <http://glamazondiaries.com/2009/07/save-your-soles-with-citisoles-ballet-flats>, depicting Citisoles flats, 3 pgs., Jul. 2009.

Pictures of Citisoles flats available for purchase in 2009, 3 pgs.

“#16 Corso Como Delicious Pumps Review and Giveaway!,” <http://www.mommatoldmeblog.com/2011/01/16-corso-como-delicious-pumps-review.html>, depicting Corso Como flats, 8 pgs., Jan. 16, 2011.

Pictures of Corso Como flats available for sale in 2011, 3 pgs.

“Jil Sander Navy Lead Ballet Flats Product . . .,” [www.ebay.com](http://www.ebay.com), depicting Jil Sander flats, 4 pgs., Nov. 2013.

Pictures of Jil Sander flats available for sale in 2011, 3 pgs.

“Spare Soles: Shoes That Roll-up & Fold-up,” <http://herpackinglist.com/2011/01/spare-soles-shoes/>, depicting Spare Soles flats, 2 pgs., Jan. 2011.

Pictures of Spare Soles flats available for sale in 2011, 5 pgs.

Pictures of Roll-Upz by Spare Soles flats available for sale in 2011, 6 pgs.

“The Cutest Blog, Preppy 50 and Loving Lilly, Ballet Flat Delight,” <http://preppy50andlovinglilly.blogspot.com/2011/02/ballet-flat-delight.html>, depicting Henri Bendel flats, 1 pg., Feb. 19, 2011.

Pictures of Henri Bendel flats available for sale in 2011, 4 pgs.

“Mumsnet by parents for parents,” [http://www.mumsnet.com/Talk/style\\_and\\_beauty/a1612000-Anyone-tried-Redfoot-Flatmates-foldable-ballet-pumps](http://www.mumsnet.com/Talk/style_and_beauty/a1612000-Anyone-tried-Redfoot-Flatmates-foldable-ballet-pumps), depicting Redfoot Flatmates flats, 1 pg, Nov. 14, 2012.

Pictures of Redfoot Flatmates flats available for sale in 2011, 6 pgs.

“Amazon.com: Customer Reviews: Bloch London Women’s Lux Ballet Flat,” <http://www.amazon.com/Bloch-London-Womens-Ballet-Flat/product-reviews/B004LWP7YW>, depicting Bloch London flats, 4 pgs., Dec. 11, 2011.

Pictures of Bloch London flats offered for sale in 2011, 11 pgs.

“h&m foldable leopard print flat,” <https://8485shops.wordpress.com/2011/06/16/flats-for-7-bucks/shoe1/>, depicting h&m flats, 2 pgs., Jun. 16, 2011.

Pictures of h&m foldable flats offered for sale in 2011, 4 pgs.

“Seekyt—Juicy Couture Ballet Flats—Are They Worth The Money?,” <http://seekyt.com/juicy-couture-ballet-flats-are-they-worth-the-money/>, 2 pgs., Jun. 3, 2011.

Pictures of Juicy Couture flats offered for sale in 2011, 3 pgs.

“Purse Flats,” <http://purseflats.wordpress.com>, depicting Purse Flats by Erica Wilson, 3 pgs., Jul. 12, 2012.

Pictures of Purse Flats by Erica Wilson offered for sale in 2011, 6 pgs.

“Tieks by Gavrieli—Comfortable, designer flats you can fit in your purse and wear all . . .,” <http://web.archive.org/web/20110202210649/http://www.tieks.com/>, 8 pgs., Feb. 2, 2011.

“Carolina M. M. Goncalves > Tieks by Gavrieli,” [http://m2.facebook.com/Tieks?v=timeline&filter=2&timecutoff=1406427986&page=17&sectionLoadingID=m\\_timeline\\_loading\\_div\\_1293868799\\_1262332800\\_8\\_17&timeend=1293868799&timestart=1262332800&tm=AQDOvqhWQPN\\_Nbwm&refid=17](http://m2.facebook.com/Tieks?v=timeline&filter=2&timecutoff=1406427986&page=17&sectionLoadingID=m_timeline_loading_div_1293868799_1262332800_8_17&timeend=1293868799&timestart=1262332800&tm=AQDOvqhWQPN_Nbwm&refid=17), 1 pg. Jan. 26, 2010.

“The Shoes Oprah Would Wear to Work (if She Had to Walk),” <http://www.inc.com/30under30/christina-desmarais/kfir-gavrieli-and-elram-gavrieli-founders-of-tieks.html>, 2 pgs., Jul. 2, 2012.

“Tieks by Gavrieli,” [http://m2.facebook.com/Tieks?v=timeline&filter=2&timecutoff=1406427986&page=14&sectionLoadingID=m\\_timeline\\_loading\\_div\\_1293868799\\_1262332800\\_8\\_14&timeend=1293868799&timestart=1262332800&tm=AQDOvqhWQPN\\_Nbwm&refid=17](http://m2.facebook.com/Tieks?v=timeline&filter=2&timecutoff=1406427986&page=14&sectionLoadingID=m_timeline_loading_div_1293868799_1262332800_8_14&timeend=1293868799&timestart=1262332800&tm=AQDOvqhWQPN_Nbwm&refid=17), 4 pgs., Jan. 26, 2010.

“Mighty Life List, Sensible Shoes,” <http://mightygirl.com/2010/08/24/sensible-shoes/>, 11 pgs., Aug. 24, 2010.

“Find! Tieks: Fab & sexy flats for fall,” <http://thefabmom.com/2013/08/29/find-tieks-fab-sexy-flats-for-fall/>, 3 pgs. Aug. 29, 2013.

“Step into Tieks,” <http://sliceofpink.typepad.com/blog/2010/09/tieks-1.html>, 5 pgs., Sep. 22, 2010.

“In Need of Flat-Soled Shoes,” <http://www.kellywickham.com/mochamomma/2010/10/4/in-need-of-flat-soled-shoes.html>, 4 pgs., Oct. 3, 2010.

“Say Hello to the Flat Shoes You Need for Fall . . . All 88 of Them!”, Picture of Adam Tucker Shoe/Slipper, <https://www.facebook.com/search/top/?q=adam%20shoes%20slipper>, last accessed Oct. 28, 2016, dated Oct. 1, 2013, 1 page.

Picture of Adam Tucker Rainbow Shoes, <https://www.facebook.com/search/top/?q=adam%20shoes%20rainbow>, last accessed Oct. 28, 2016, dated Aug. 14, 2013, 1 page.

\* cited by examiner

*Primary Examiner* — Dominic V Simone

(74) *Attorney, Agent, or Firm* — Morgan, Lewis & Bockius LLP

(57) **CLAIM**

The ornamental design for a ballet shoe, as shown and described.

**DESCRIPTION**

The file of this patent contains at least one drawing executed in color. Copies of this patent with color drawing(s) will be provided by the Office upon request and payment of the necessary fee.

FIG. 1 is a perspective view of an embodiment of our new design of a ballet shoe;

FIG. 2 is a first side view of the design of FIG. 1;

FIG. 3 is a second side view of the design of FIG. 1;

FIG. 4 is a top view of the design of FIG. 1;

FIG. 5 is a bottom view of the design of FIG. 1;

FIG. 6 is a front view of the design of FIG. 1;

FIG. 7 is a back view of the design of FIG. 1;

FIG. 8 is a perspective view of another embodiment of our new design of a ballet shoe, where the color portions are indicated using the USPTO convention of dashed vertical lines for violet or purple;

FIG. 9 is a first side view of the design of FIG. 8;

FIG. 10 is a second side view of the design of FIG. 8;

FIG. 11 is a top view of the design of FIG. 8;

FIG. 12 is a bottom view of the design of FIG. 8;

FIG. 13 is a front view of the design of FIG. 8;

FIG. 14 is a back view of the design of FIG. 8;

FIG. 15 is a perspective view of yet another embodiment of our new design of a ballet shoe;

FIG. 16 is a first side view of the design of FIG. 15;

FIG. 17 is a second side view of the design of FIG. 15;

FIG. 18 is a top view of the design of FIG. 15;

FIG. 19 is a bottom view of the design of FIG. 15;

FIG. 20 is a front view of the design of FIG. 15;

FIG. 21 is a back view of the design of FIG. 15;

FIG. 22 is a perspective view of yet another embodiment of our new design of a ballet shoe, where the color portions are indicated using the USPTO convention of solid diagonal lines extending from the upper left to the lower right for green;

FIG. 23 is a first side view of the design of FIG. 22;

FIG. 24 is a second side view of the design of FIG. 22;

FIG. 25 is a top view of the design of FIG. 22;

FIG. 26 is a bottom view of the design of FIG. 22;

FIG. 27 is a front view of the design of FIG. 22;

FIG. 28 is a back view of the design of FIG. 22;

FIG. 29 is a perspective view of yet another embodiment of our new design of a ballet shoe;

FIG. 30 is a first side view of the design of FIG. 29;

FIG. 31 is a second side view of the design of FIG. 29;

FIG. 32 is a top view of the design of FIG. 29;

FIG. 33 is a bottom view of the design of FIG. 29;

FIG. 34 is a front view of the design of FIG. 29;

FIG. 35 is a back view of the design of FIG. 29;

FIG. 36 is a perspective view of yet another embodiment of our new design of a ballet shoe, where the color portions are indicated using the USPTO convention of solid vertical lines for red or pink;

FIG. 37 is a first side view of the design of FIG. 36;

FIG. 38 is a second side view of the design of FIG. 36;

FIG. 39 is a top view of the design of FIG. 36;

FIG. 40 is a bottom view of the design of FIG. 36;

FIG. 41 is a front view of the design of FIG. 36;

FIG. 42 is a back view of the design of FIG. 36;

FIG. 43 is a perspective view of yet another embodiment of our new design of a ballet shoe;

FIG. 44 is a first side view of the design of FIG. 43;

FIG. 45 is a second side view of the design of FIG. 43;

FIG. 46 is a top view of the design of FIG. 43;

FIG. 47 is a bottom view of the design of FIG. 43;

FIG. 48 is a front view of the design of FIG. 43;

FIG. 49 is a back view of the design of FIG. 43;

FIG. 50 is a perspective view of yet another embodiment of our new design of a ballet shoe, where the color portions are indicated using the USPTO convention of horizontal lines for blue;

FIG. 51 is a first side view of the design of FIG. 50;

FIG. 52 is a second side view of the design of FIG. 50;

FIG. 53 is a top view of the design of FIG. 50;

FIG. 54 is a bottom view of the design of FIG. 50;

FIG. 55 is a front view of the design of FIG. 50;

FIG. 56 is a back view of the design of FIG. 50;

FIG. 57 is a perspective view of yet another embodiment of our new design of a ballet shoe, where the color portions are indicated using a cross-hatched pattern to indicate the blue color Pantone 7466C;

FIG. 58 is a first side view of the design of FIG. 57;

FIG. 59 is a second side view of the design of FIG. 57;

FIG. 60 is a top view of the design of FIG. 57;

FIG. 61 is a bottom view of the design of FIG. 57;

FIG. 62 is a front view of the design of FIG. 57;

FIG. 63 is a back view of the design of FIG. 57;

FIG. 64 is a perspective view of yet another embodiment of our new design of a ballet shoe;

FIG. 65 is a first side view of the design of FIG. 64;

FIG. 66 is a second side view of the design of FIG. 64;

FIG. 67 is a top view of the design of FIG. 64;

FIG. 68 is a bottom view of the design of FIG. 64;

FIG. 69 is a front view of the design of FIG. 64;

FIG. 70 is a back view of the design of FIG. 64;

FIG. 71 is a perspective view of yet another embodiment of our new design of a ballet shoe, where the color portions are indicated using the USPTO convention of diagonal cross-hatched lines for orange;

FIG. 72 is a first side view of the design of FIG. 71;

FIG. 73 is a second side view of the design of FIG. 71;

FIG. 74 is a top view of the design of FIG. 71;

FIG. 75 is a bottom view of the design of FIG. 71;

FIG. 76 is a front view of the design of FIG. 71;

FIG. 77 is a back view of the design of FIG. 71;

FIG. 78 is a perspective view of yet another embodiment of our new design of a ballet shoe;

FIG. 79 is a first side view of the design of FIG. 78;

FIG. 80 is a second side view of the design of FIG. 78;

FIG. 81 is a top view of the design of FIG. 78;

FIG. 82 is a bottom view of the design of FIG. 78;

FIG. 83 is a front view of the design of FIG. 78;

FIG. 84 is a back view of the design of FIG. 78;

FIG. 85 is a perspective view of yet another embodiment of our new design of a ballet shoe, where the color portions are indicated using the USPTO convention of vertical and horizontal cross-hatched lines for yellow or gold;

FIG. 86 is a first side view of the design of FIG. 85;

FIG. 87 is a second side view of the design of FIG. 85;

FIG. 88 is a top view of the design of FIG. 85;

FIG. 89 is a bottom view of the design of FIG. 85;

FIG. 90 is a front view of the design of FIG. 85; and,

FIG. 91 is a back view of the design of FIG. 85.

The broken lines illustrating the half moon patch, the rear outsole patch, the groove, and the heel stripe in the above described Figures are for illustrative purposes only and form no part of the claimed design.

**1 Claim, 78 Drawing Sheets  
(30 of 78 Drawing Sheet(s) Filed in Color)**

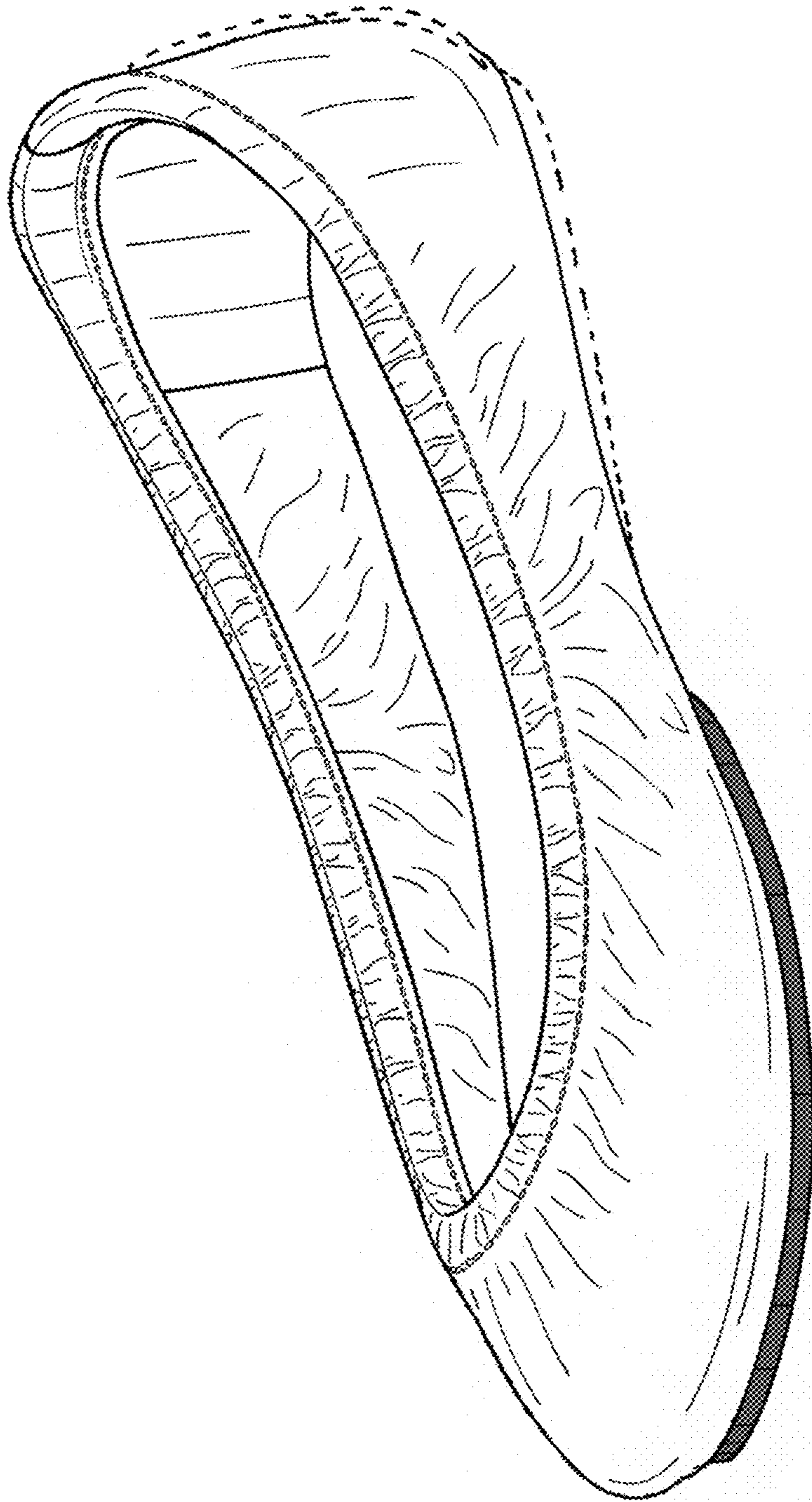

FIG. 1

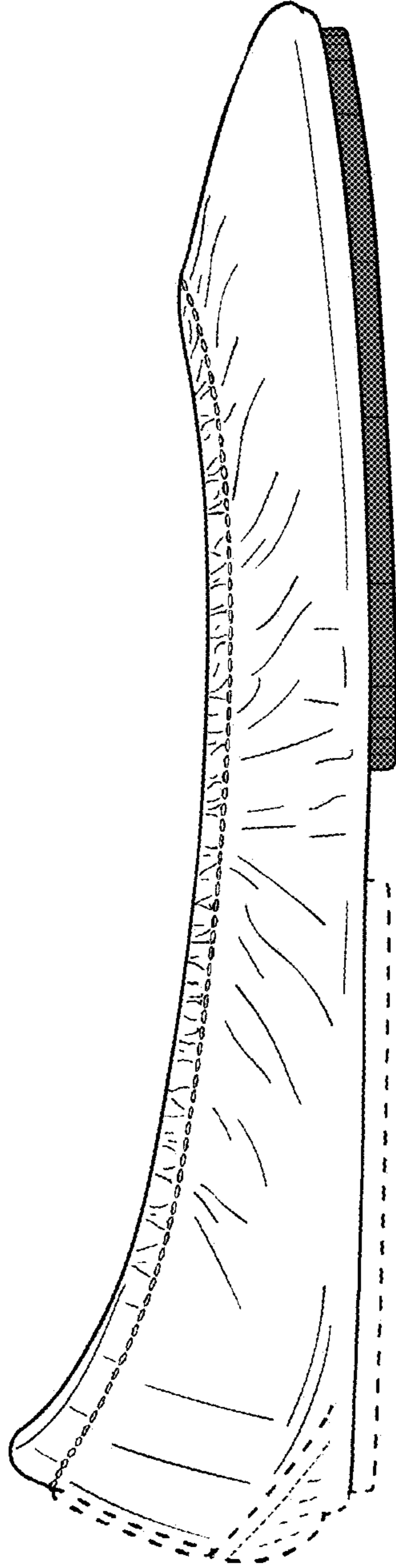

FIG. 2

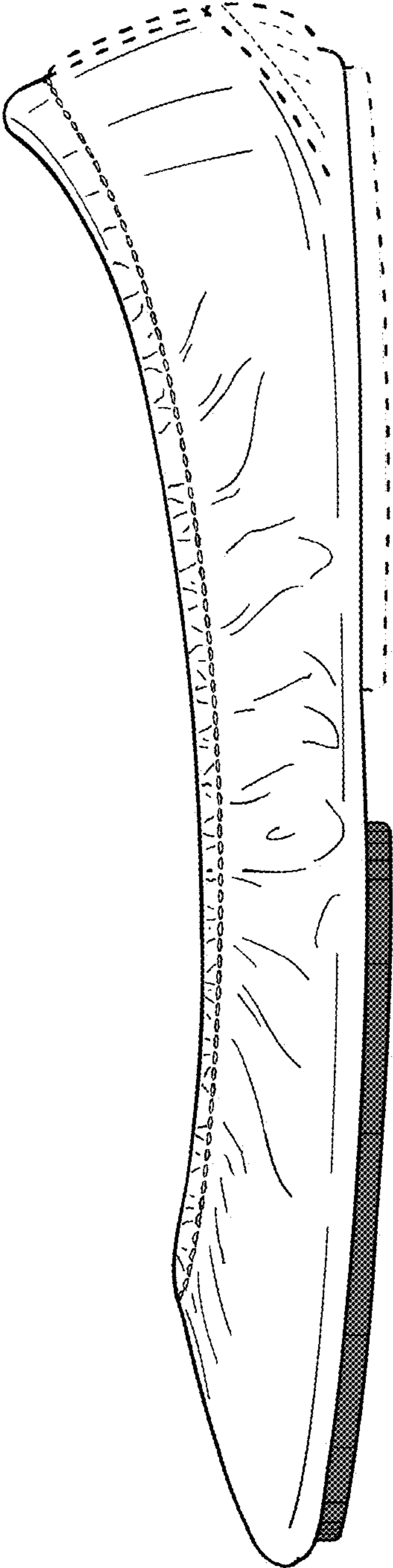

FIG. 3

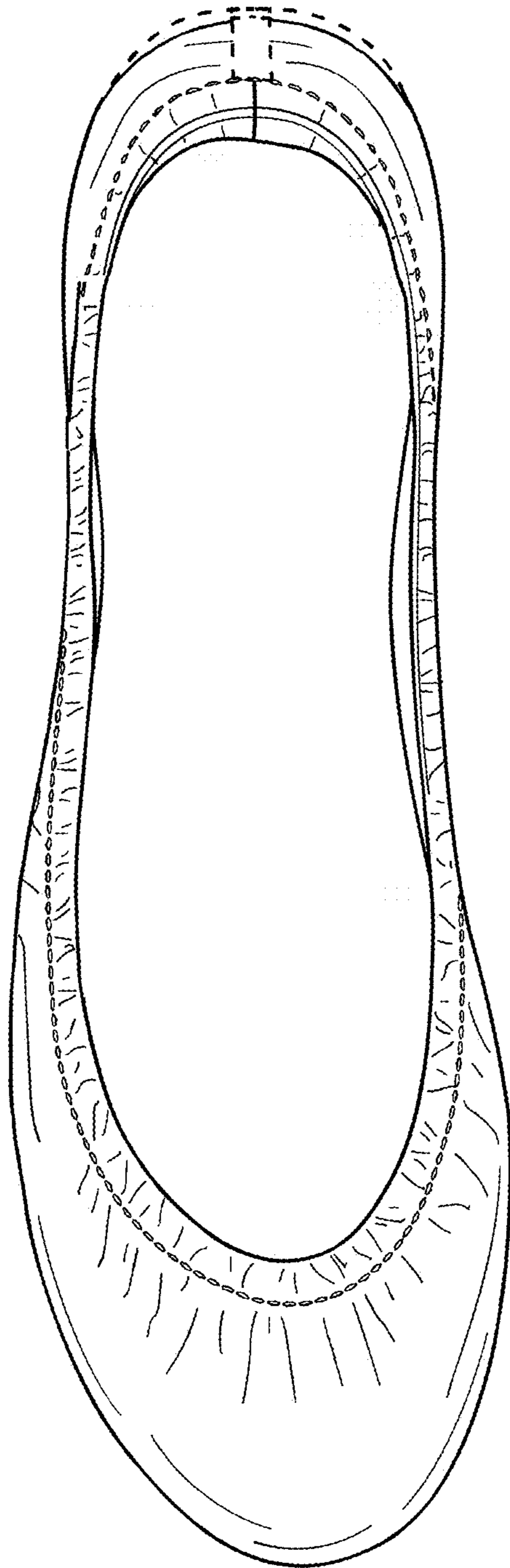

FIG. 4



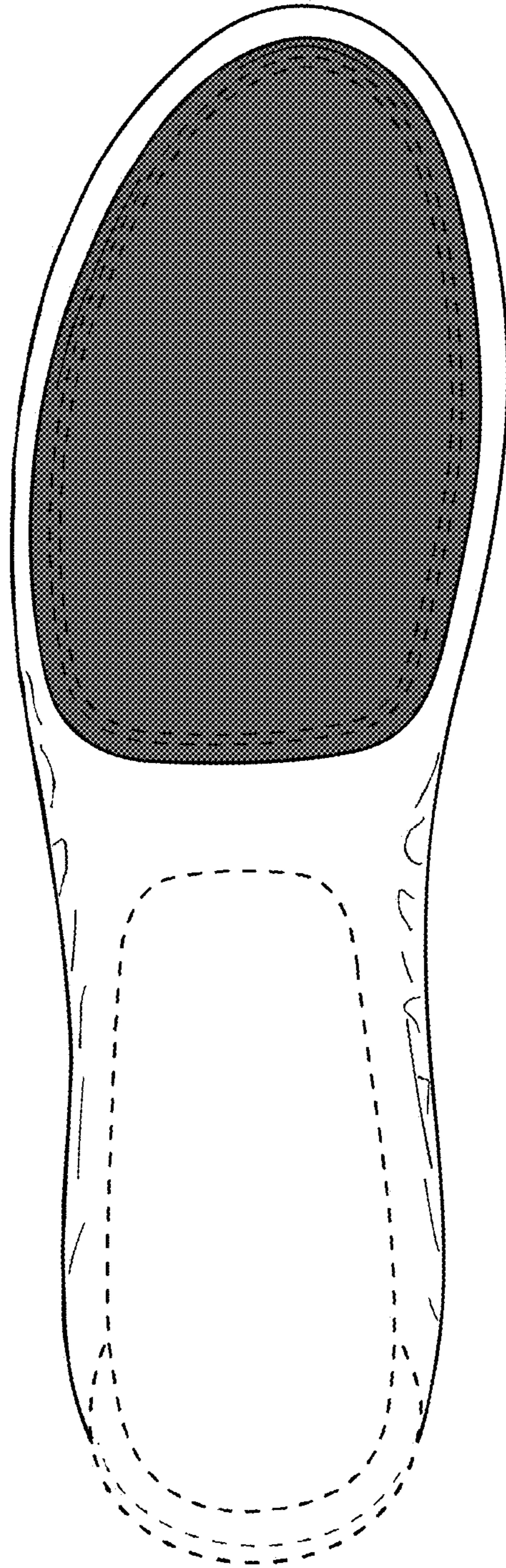

FIG. 5

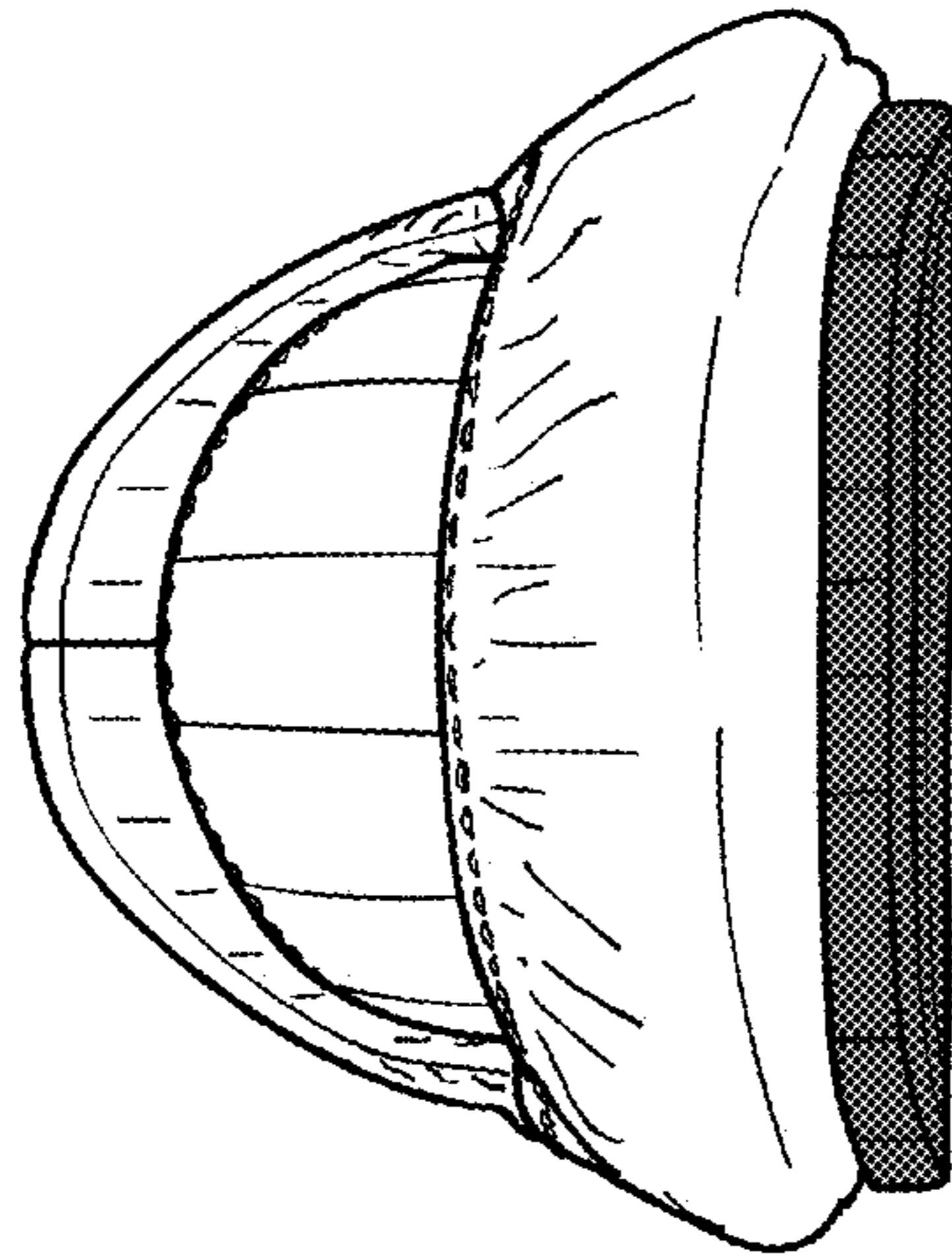

FIG. 6

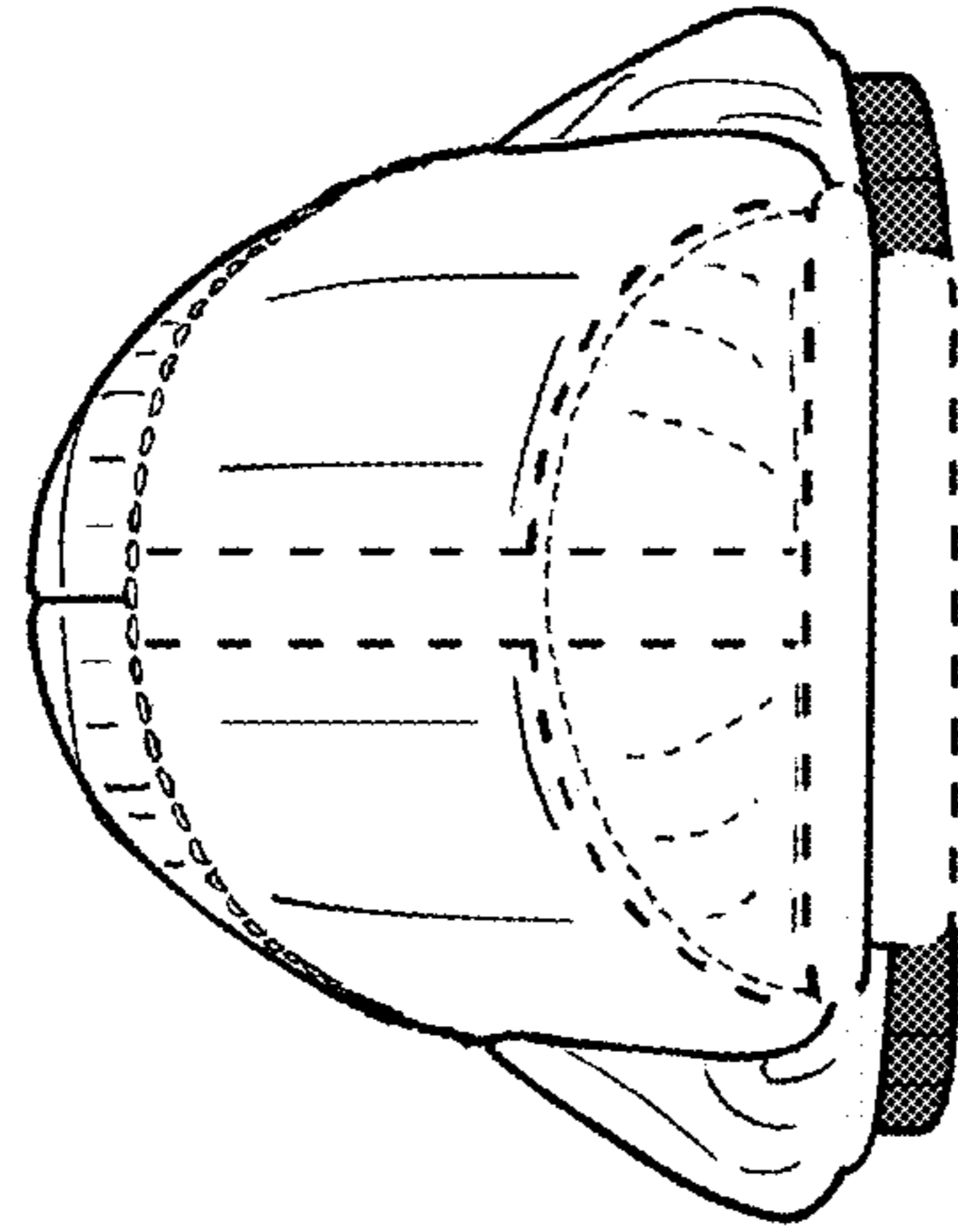

FIG. 7

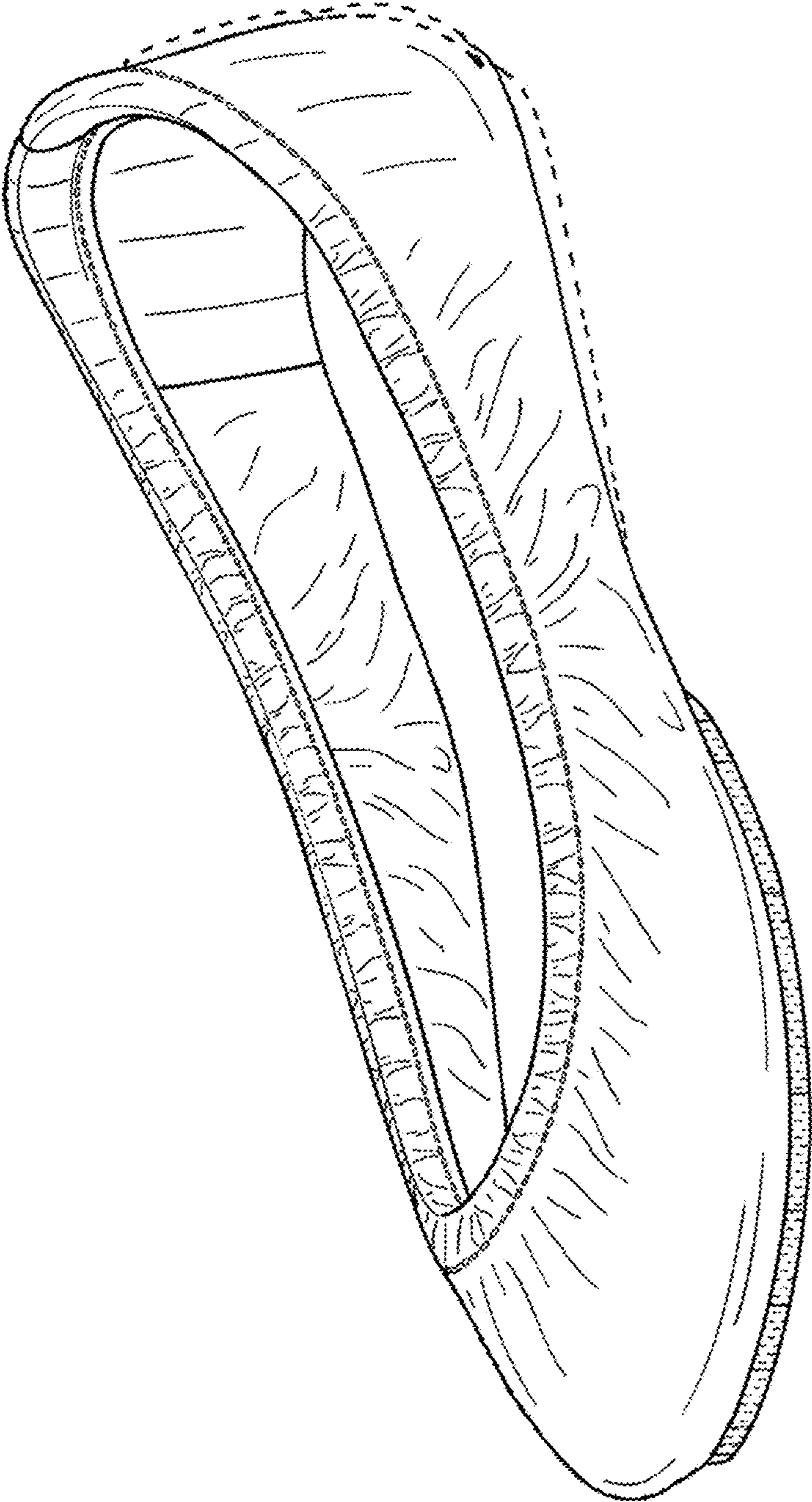

FIG. 8

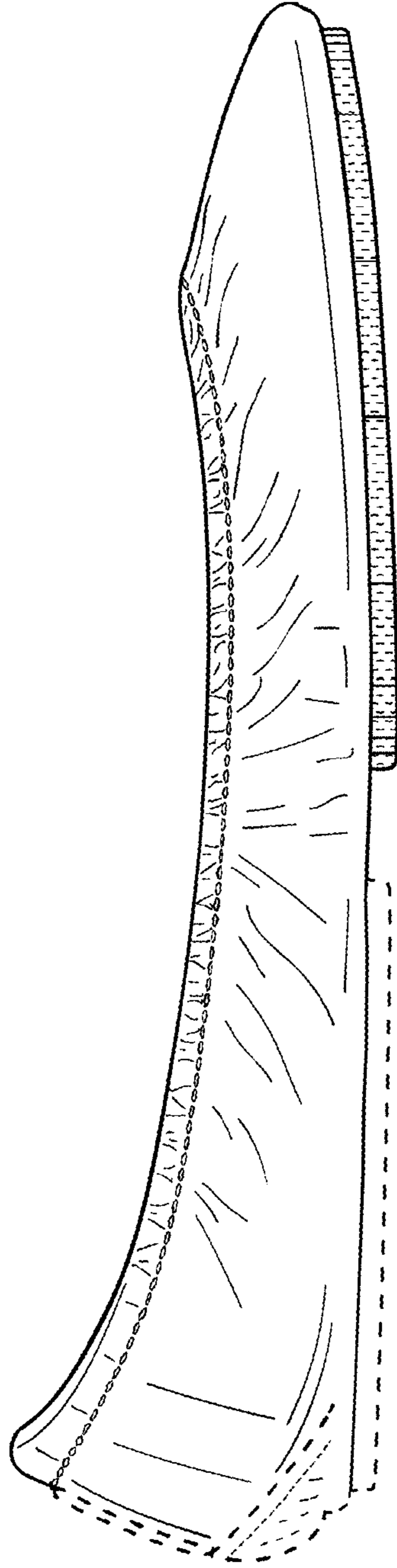

FIG. 9

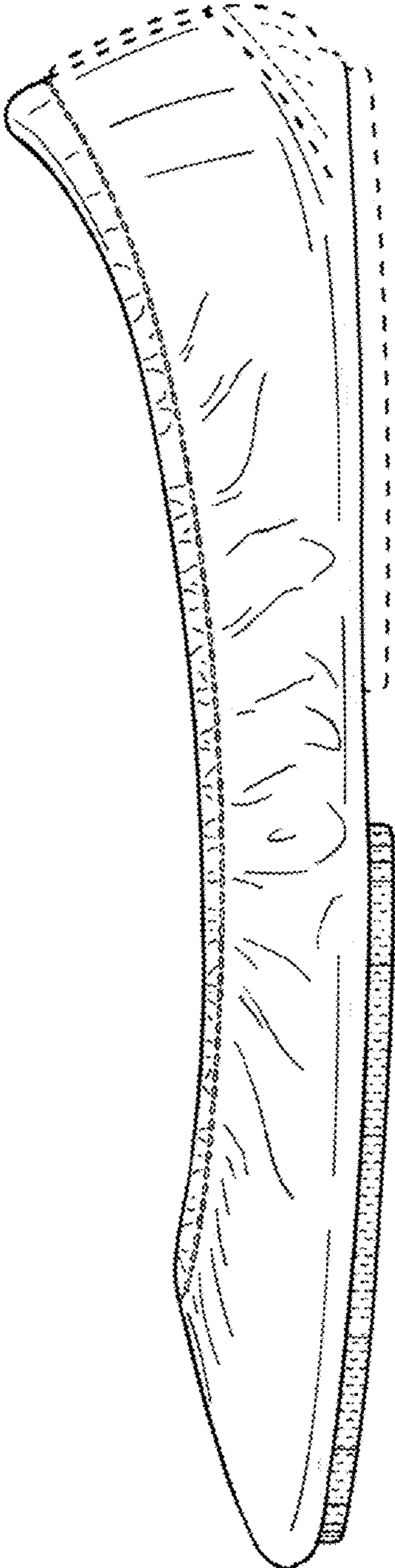

FIG. 10

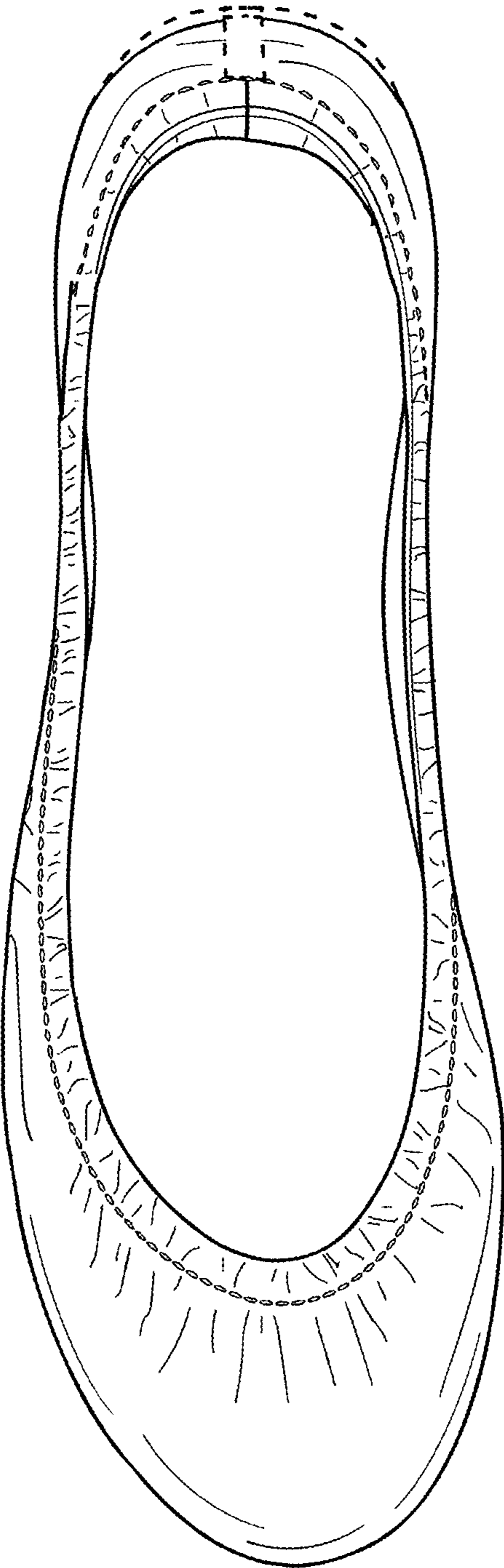

FIG. 11

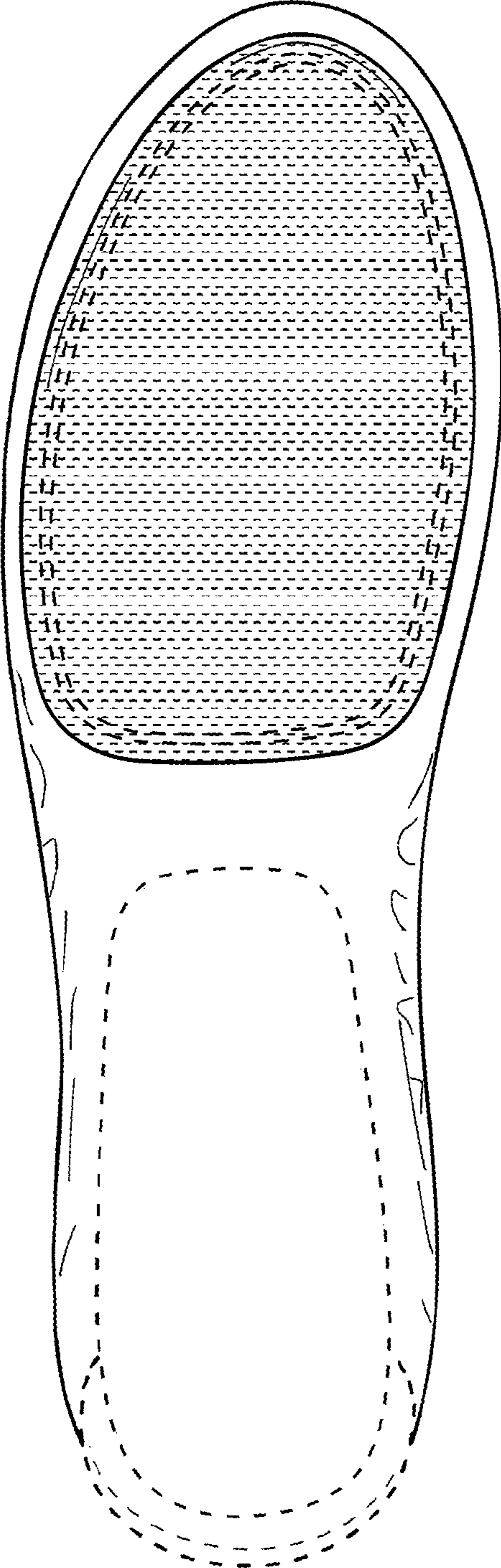

FIG. 12

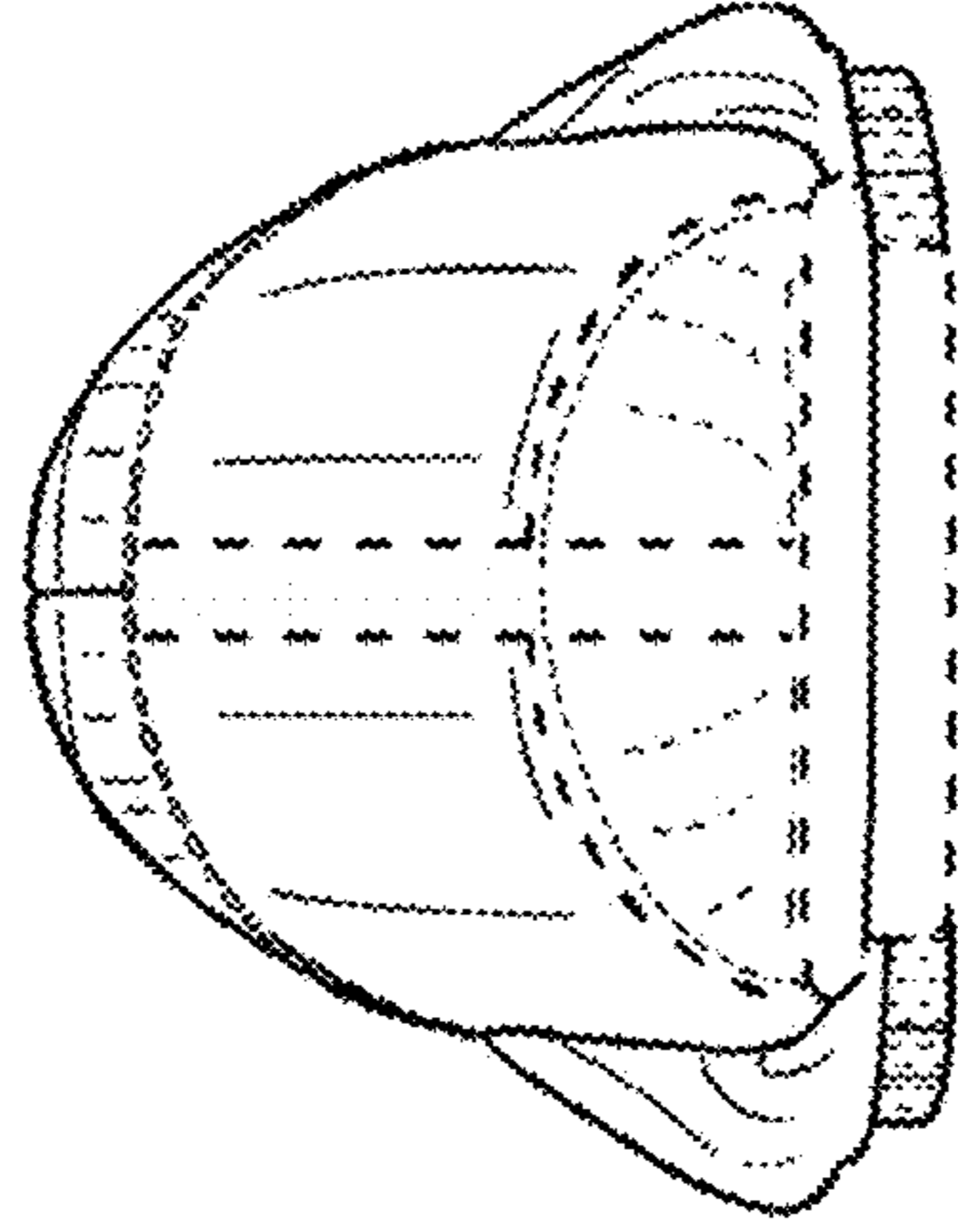

FIG. 14

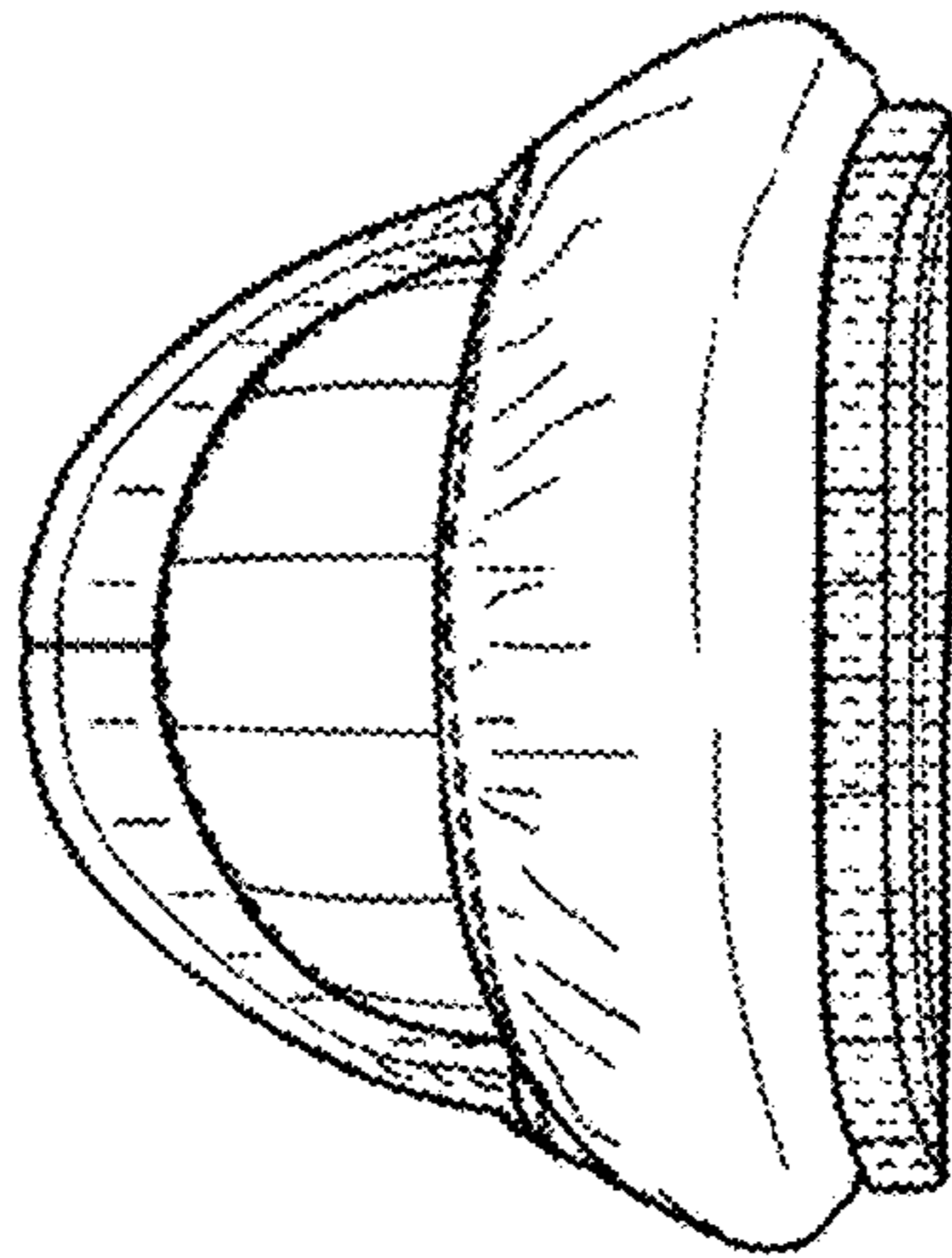

FIG. 13



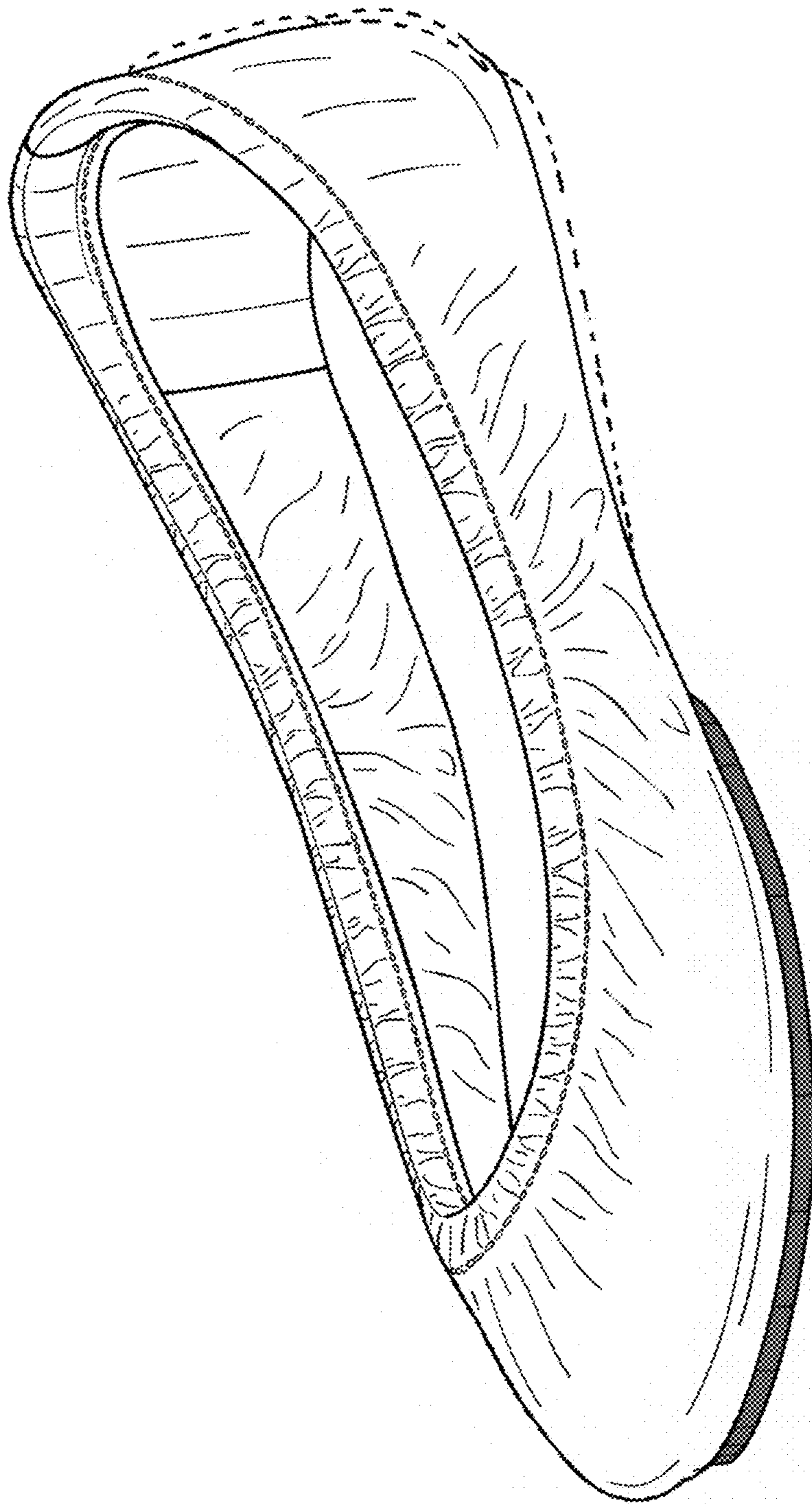

FIG. 15

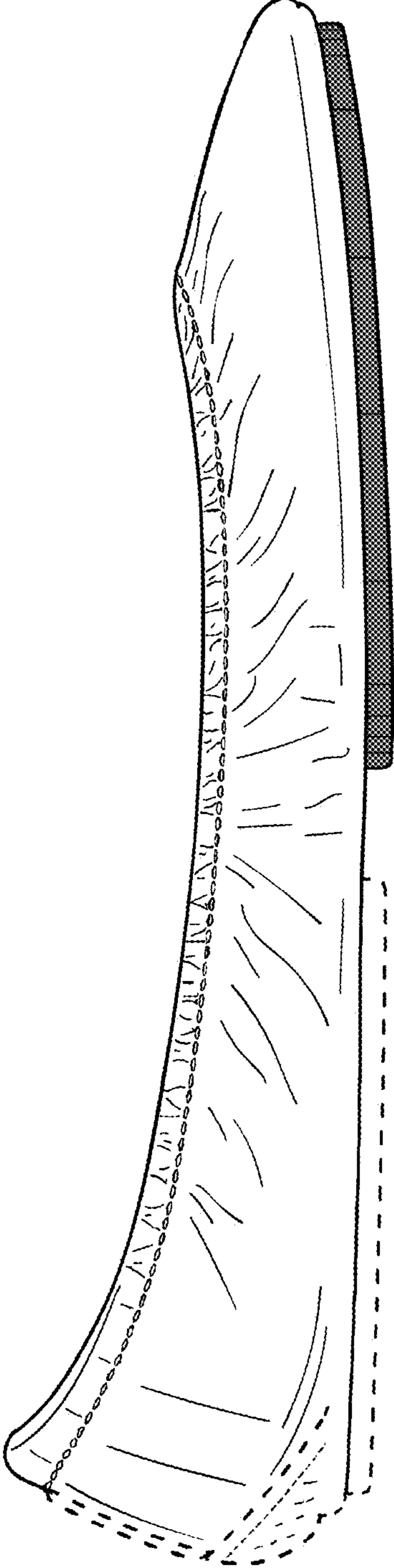

FIG. 16

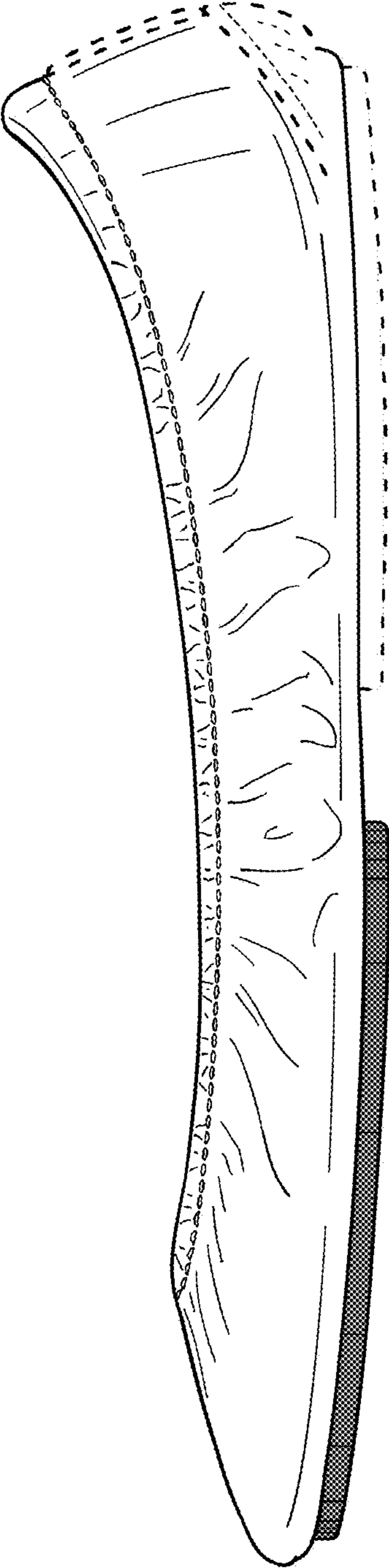

FIG. 17

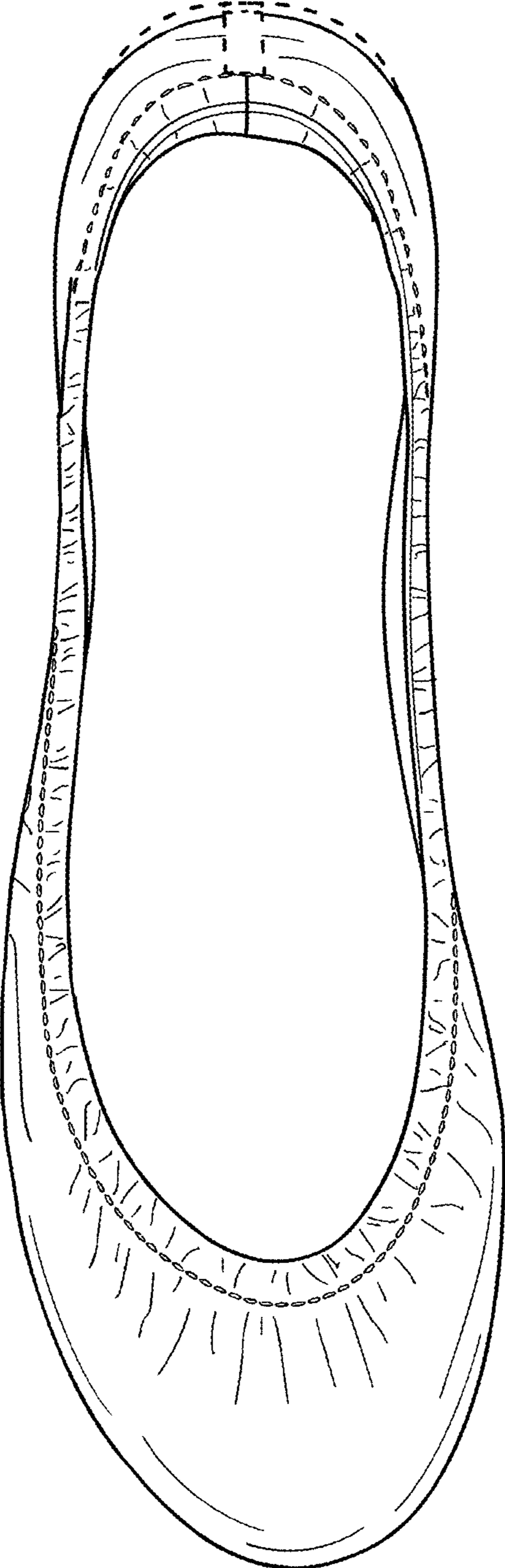

FIG. 18

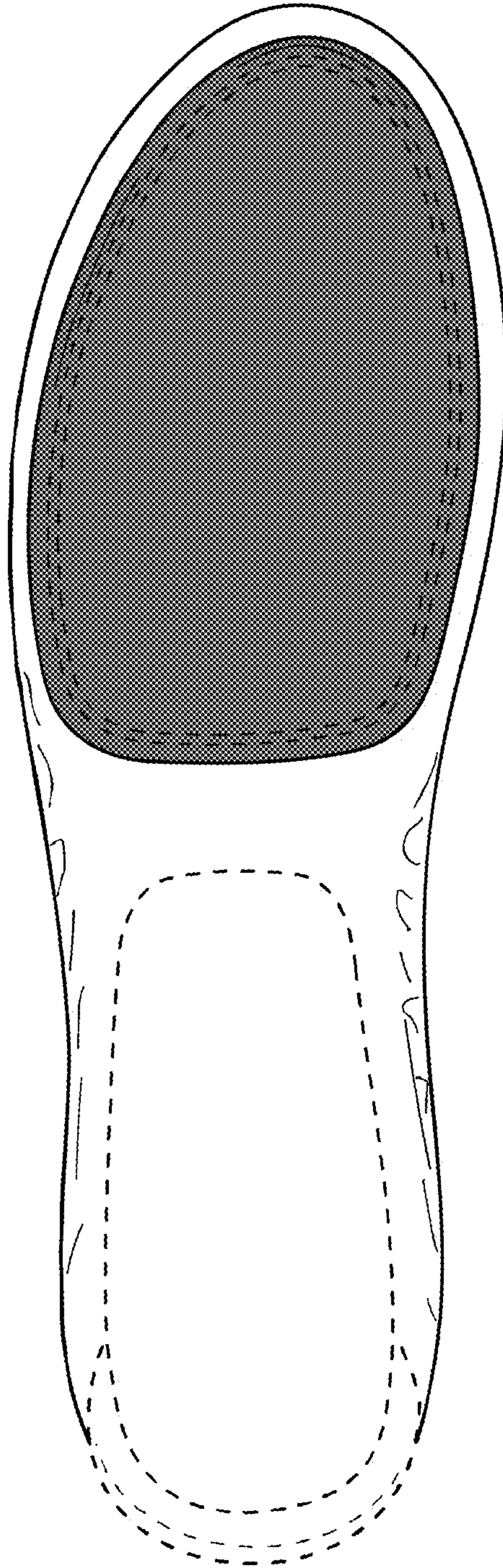

FIG. 19

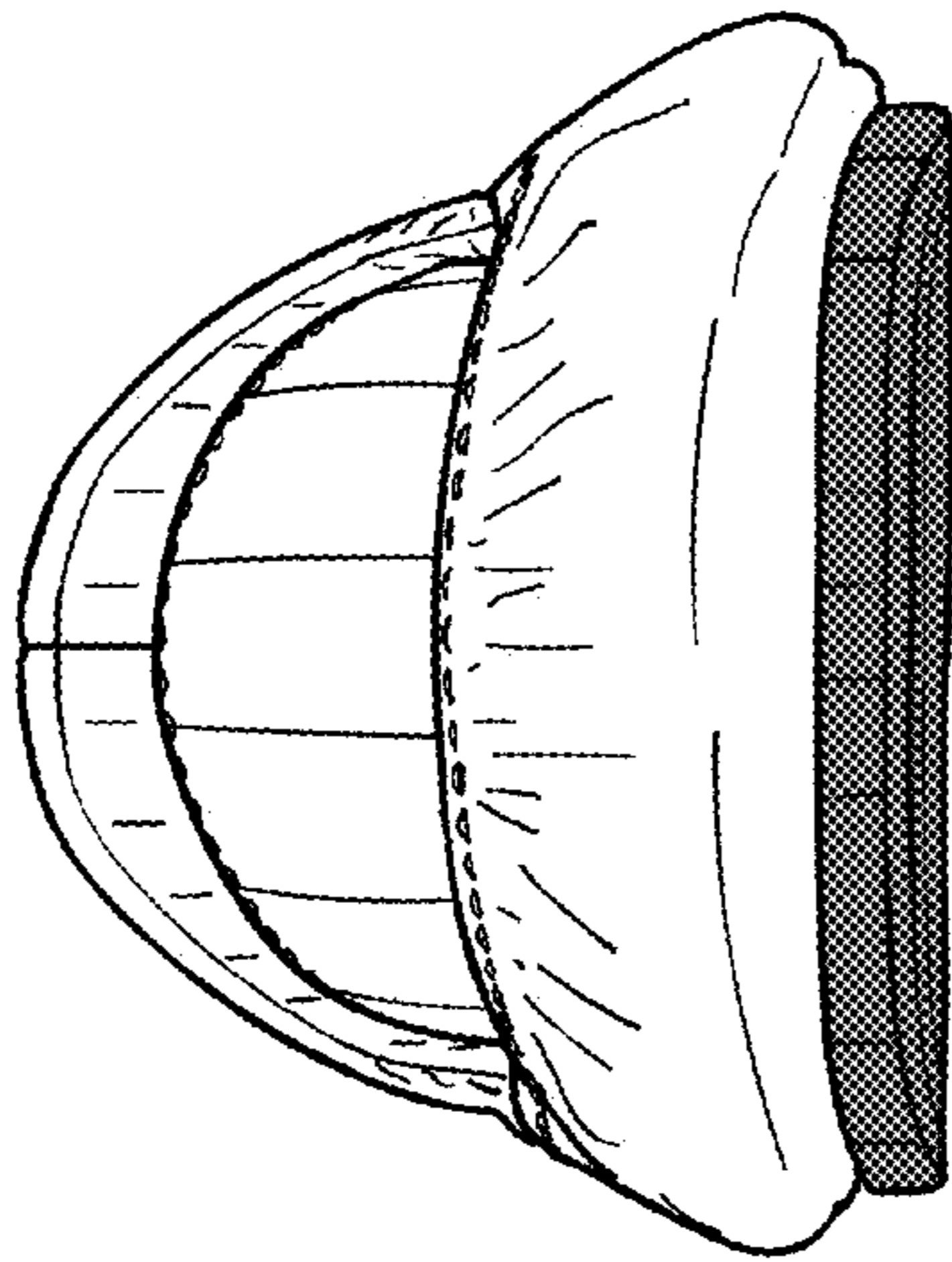

FIG. 20

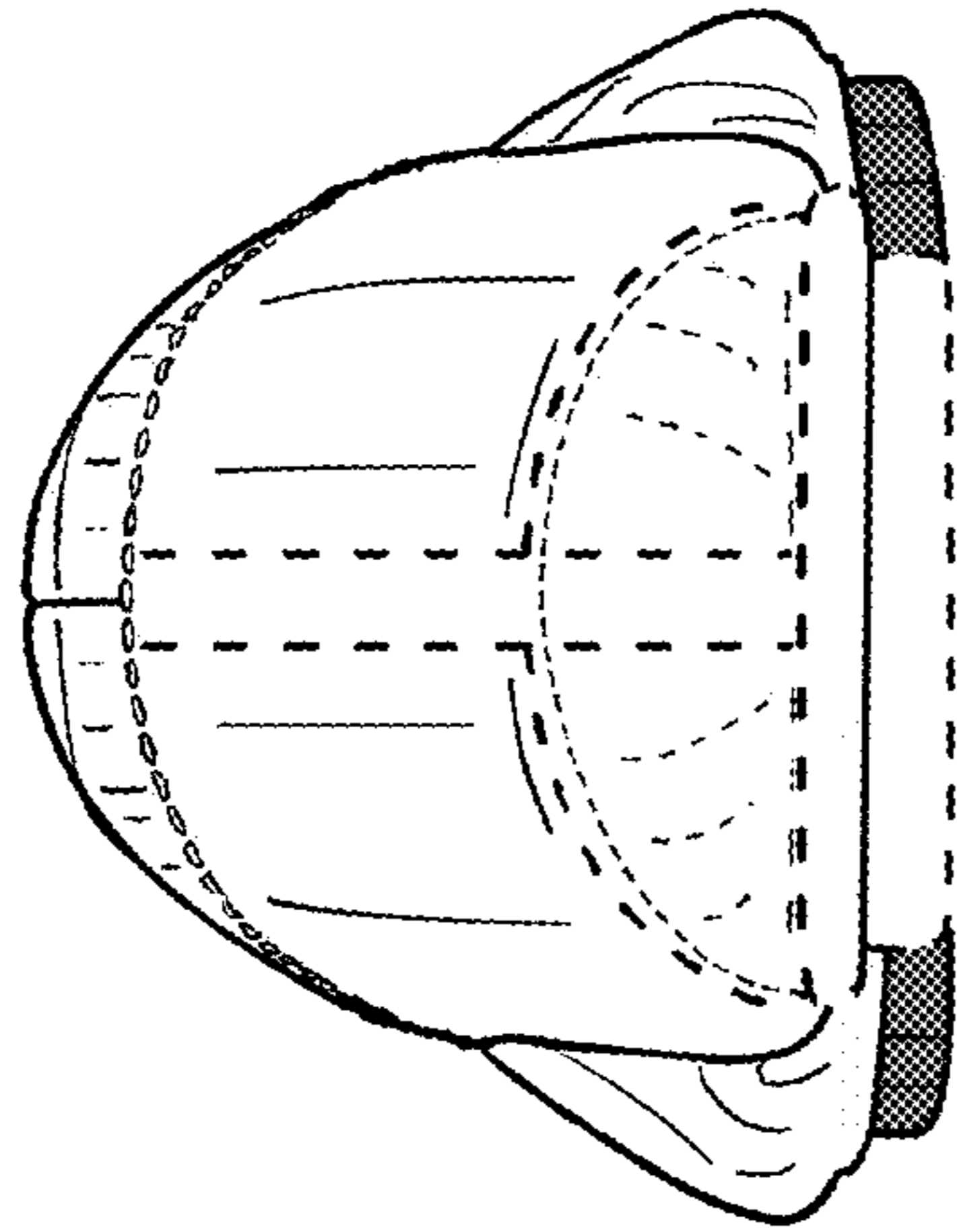

FIG. 21

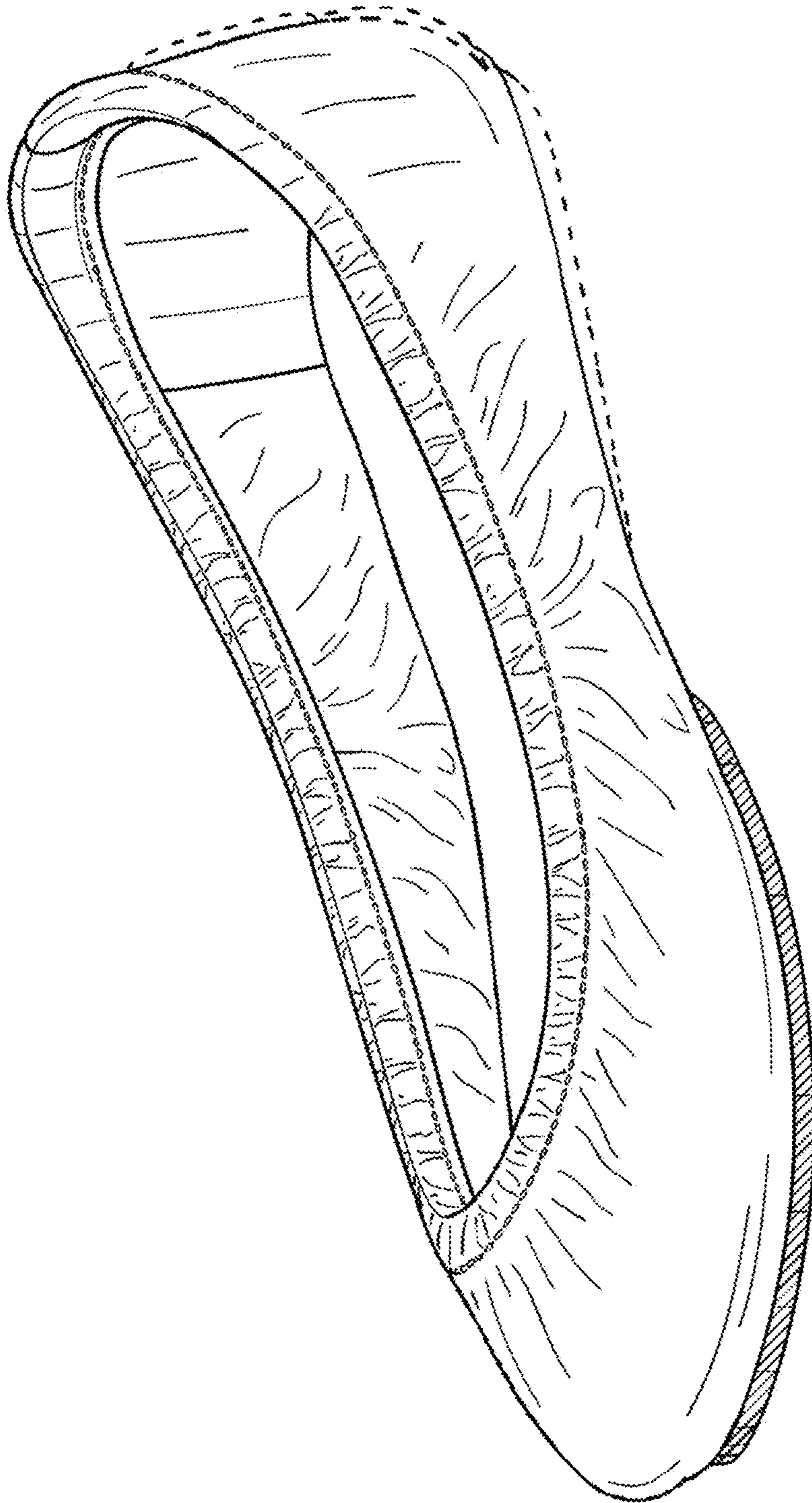

FIG. 22

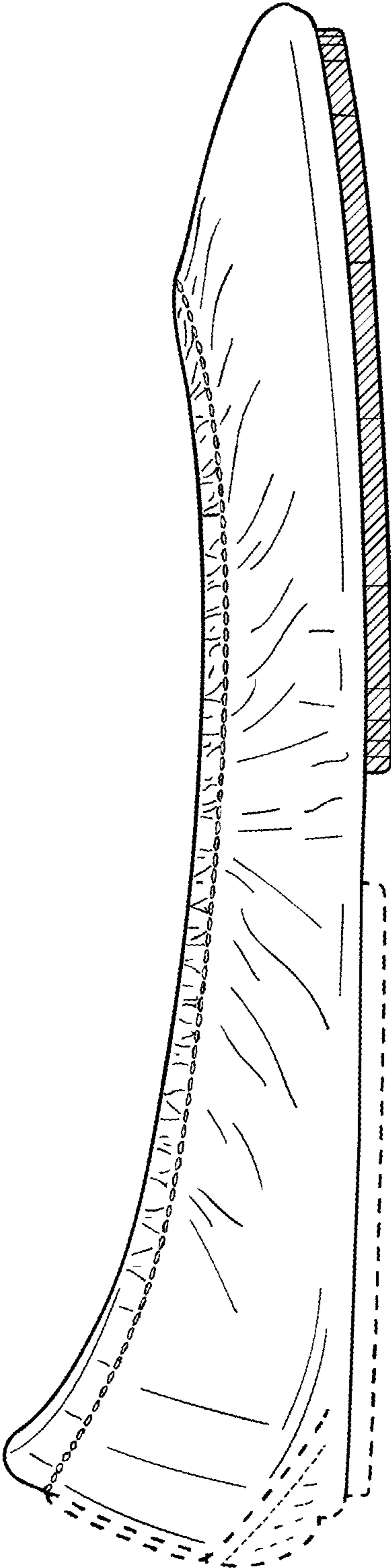

FIG. 23



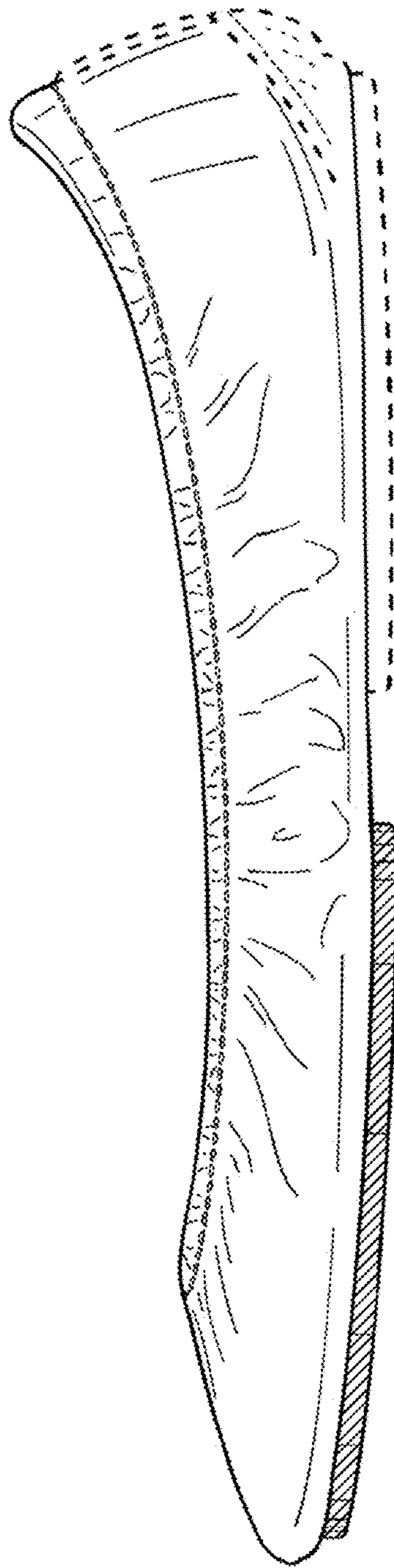

FIG. 24

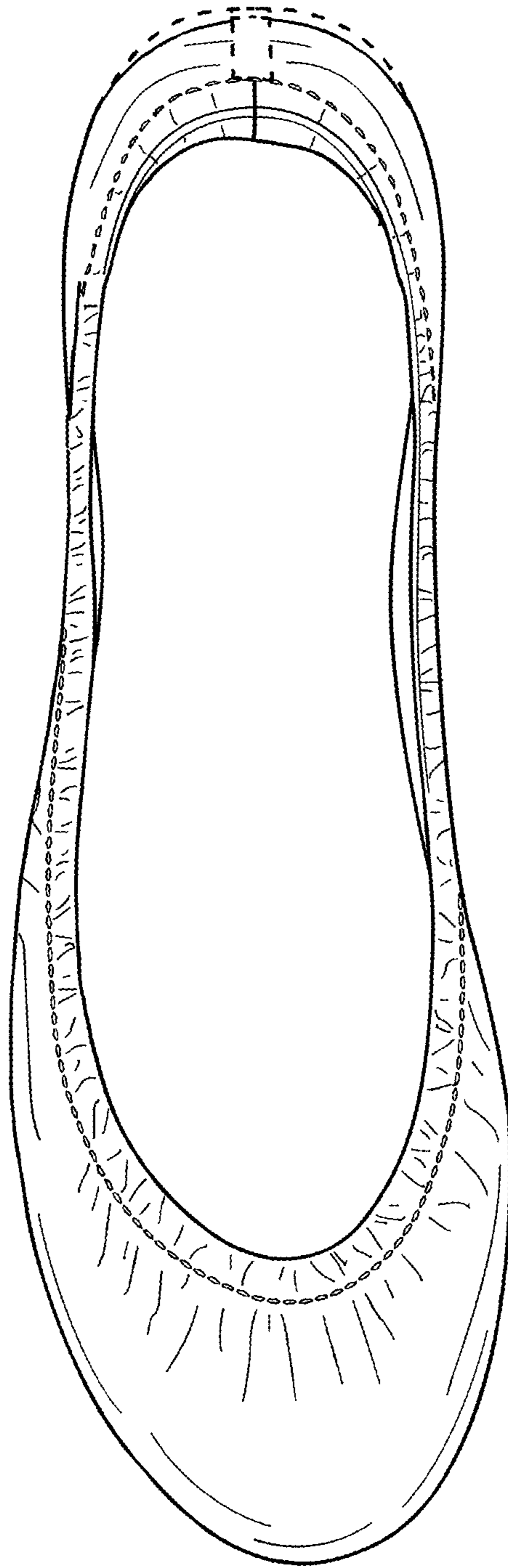

FIG. 25

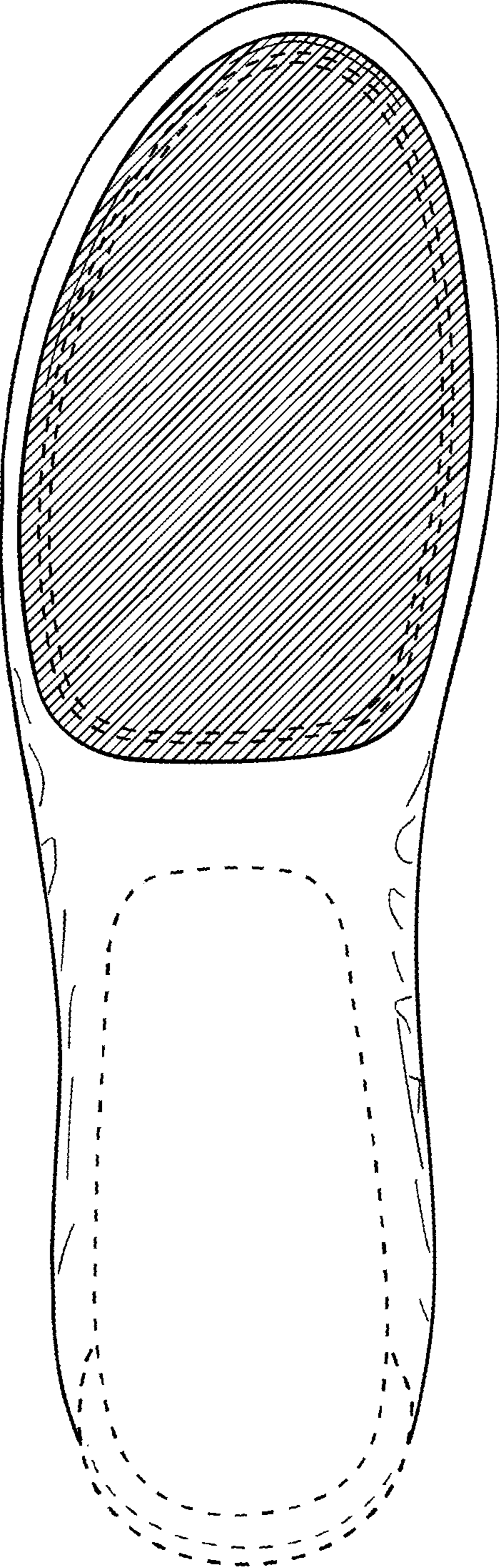

FIG. 26

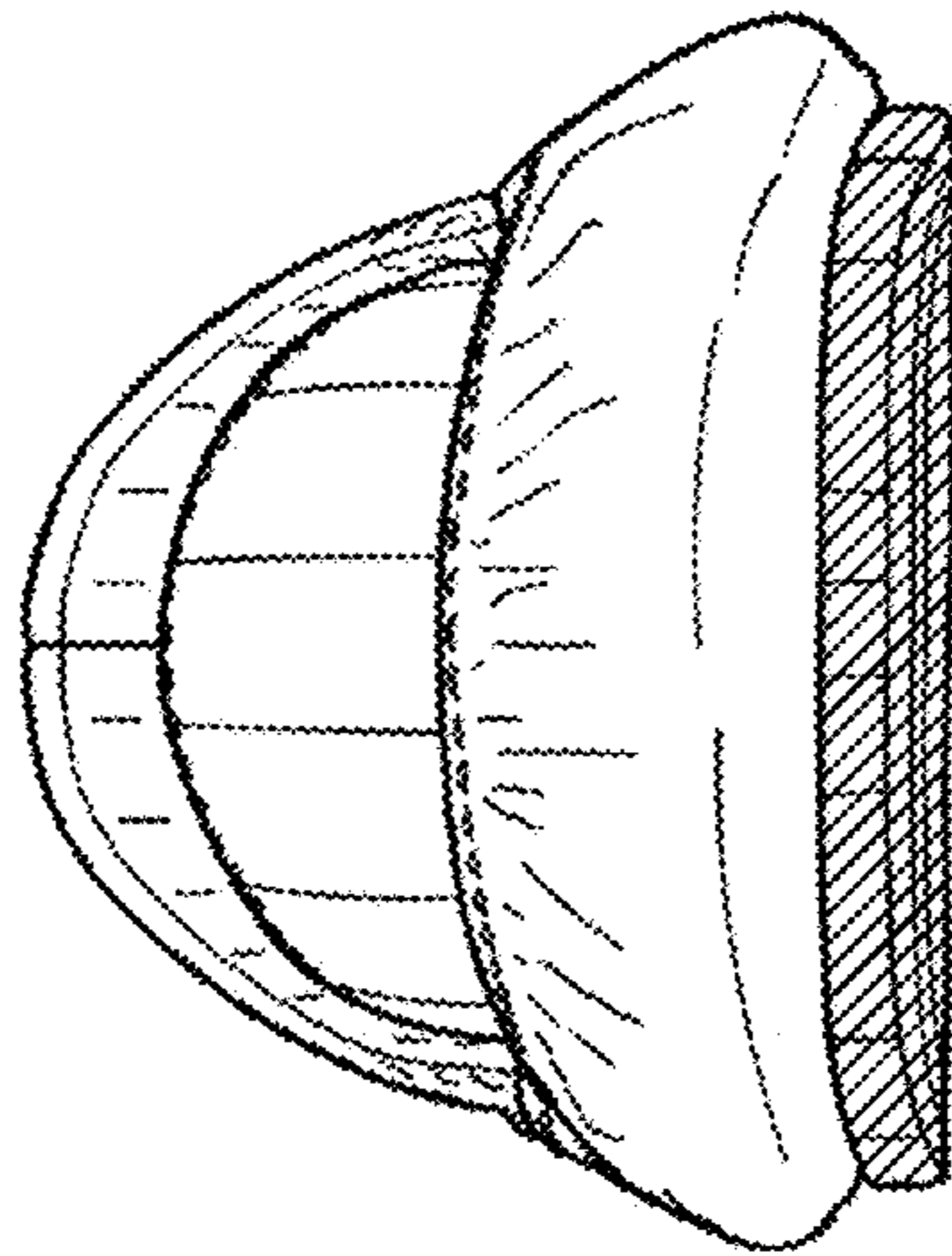

FIG. 27

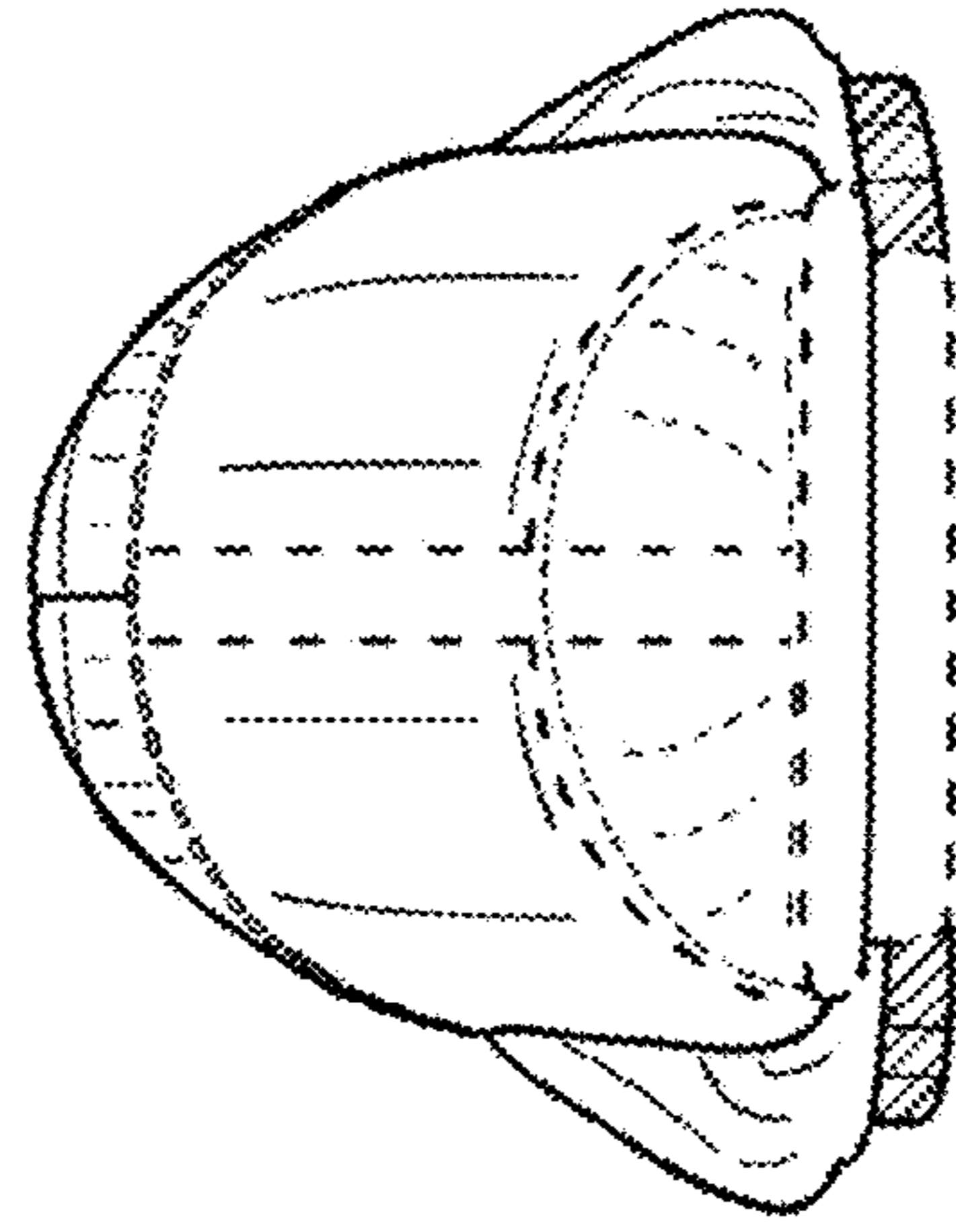

FIG. 28

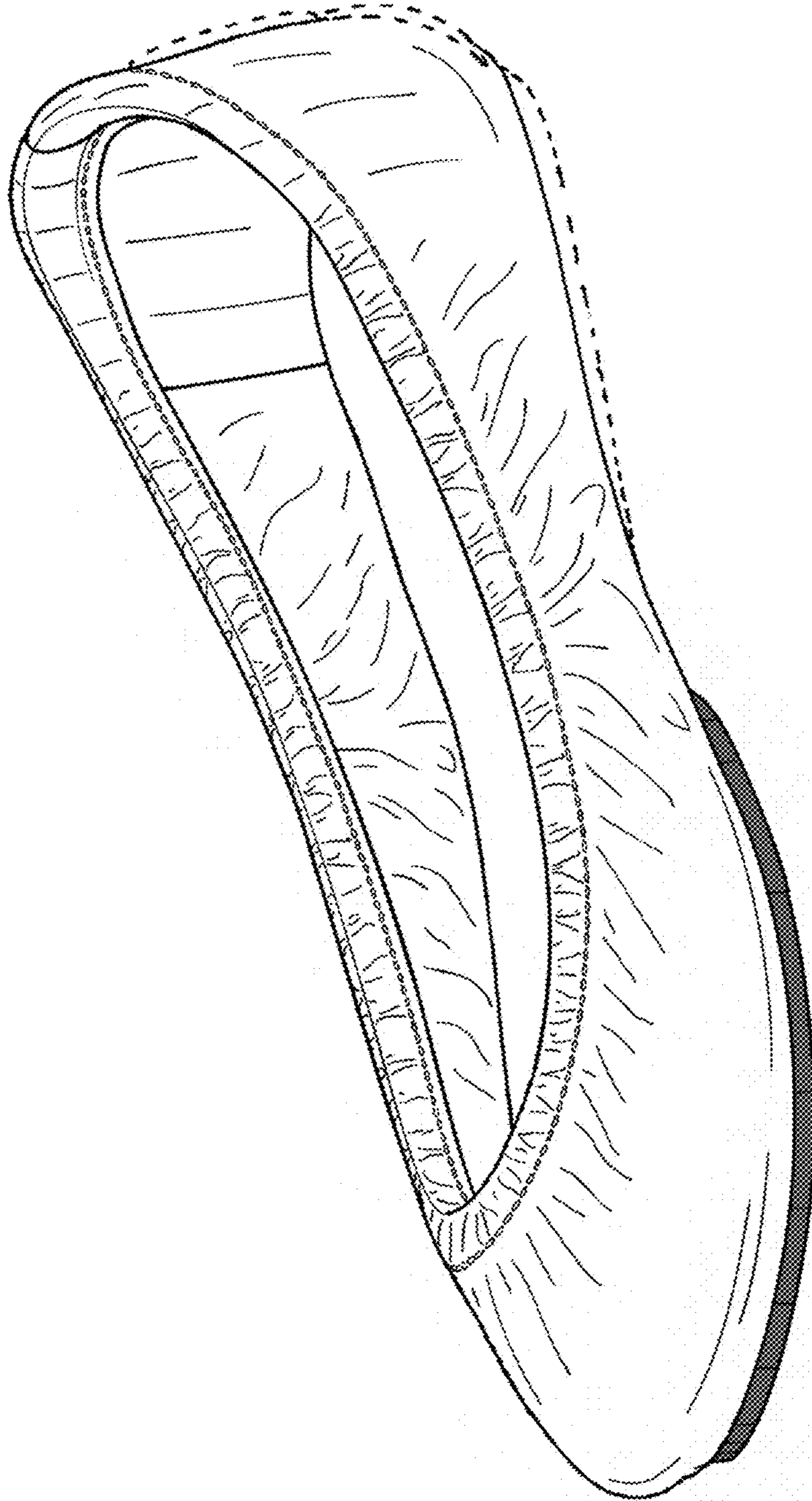

FIG. 29

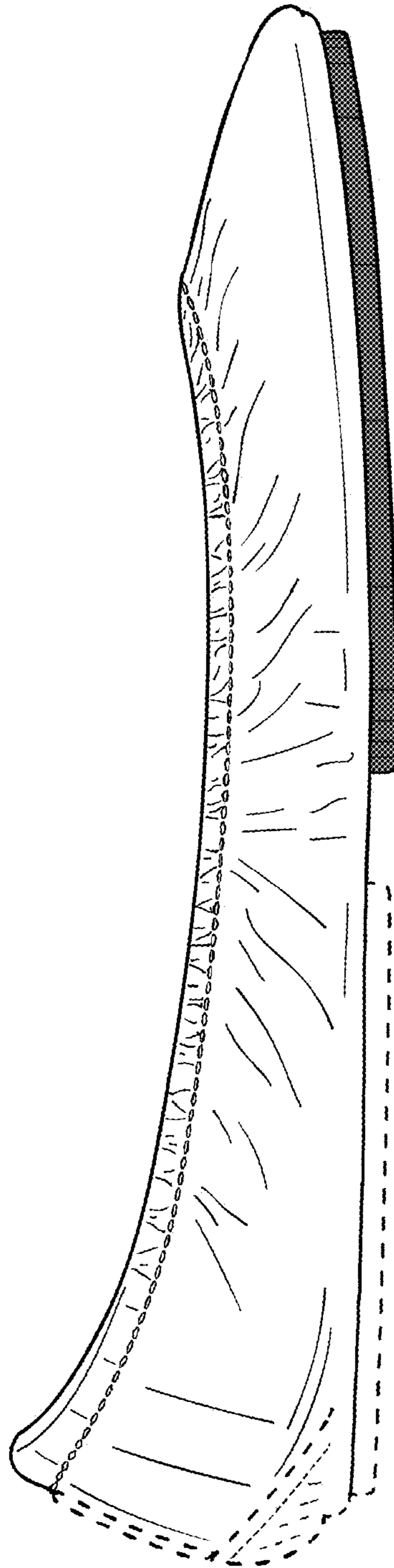

FIG.30

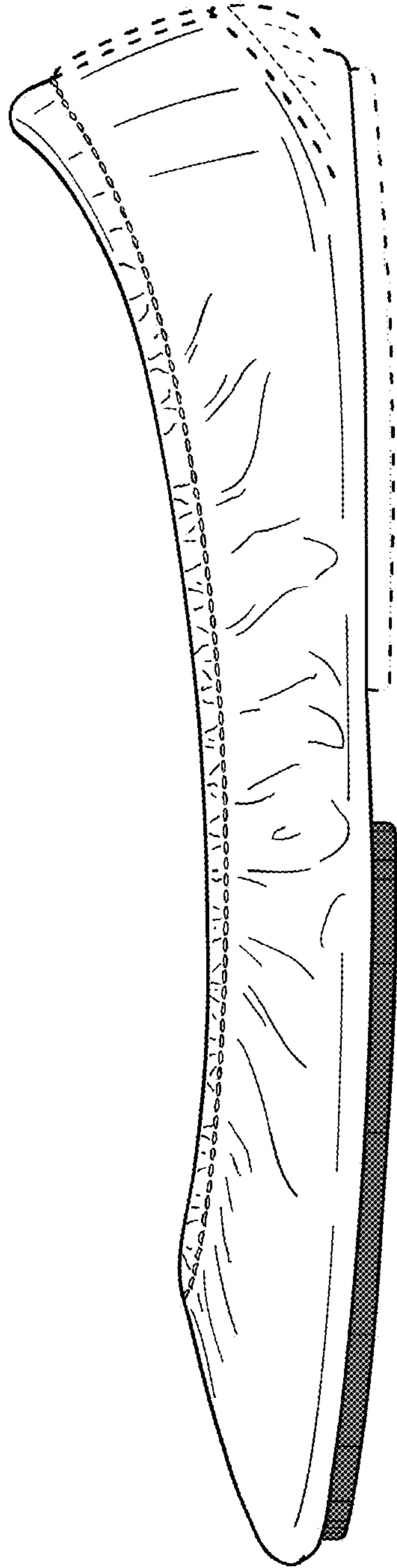

FIG. 31

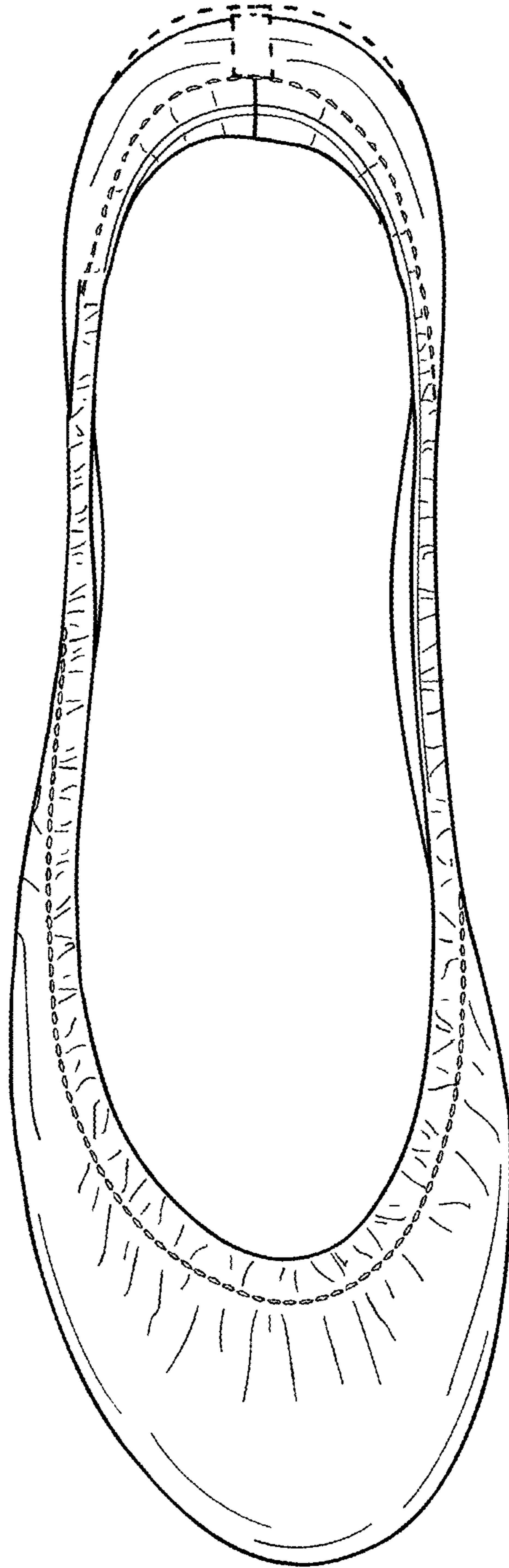

FIG. 32



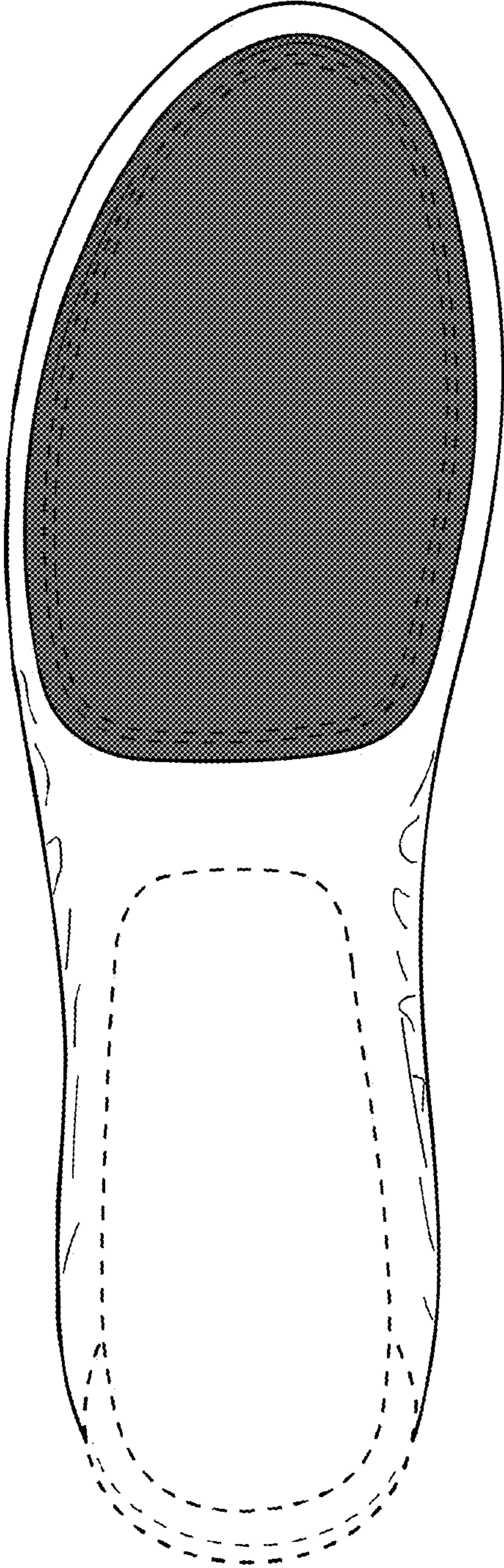

FIG. 33

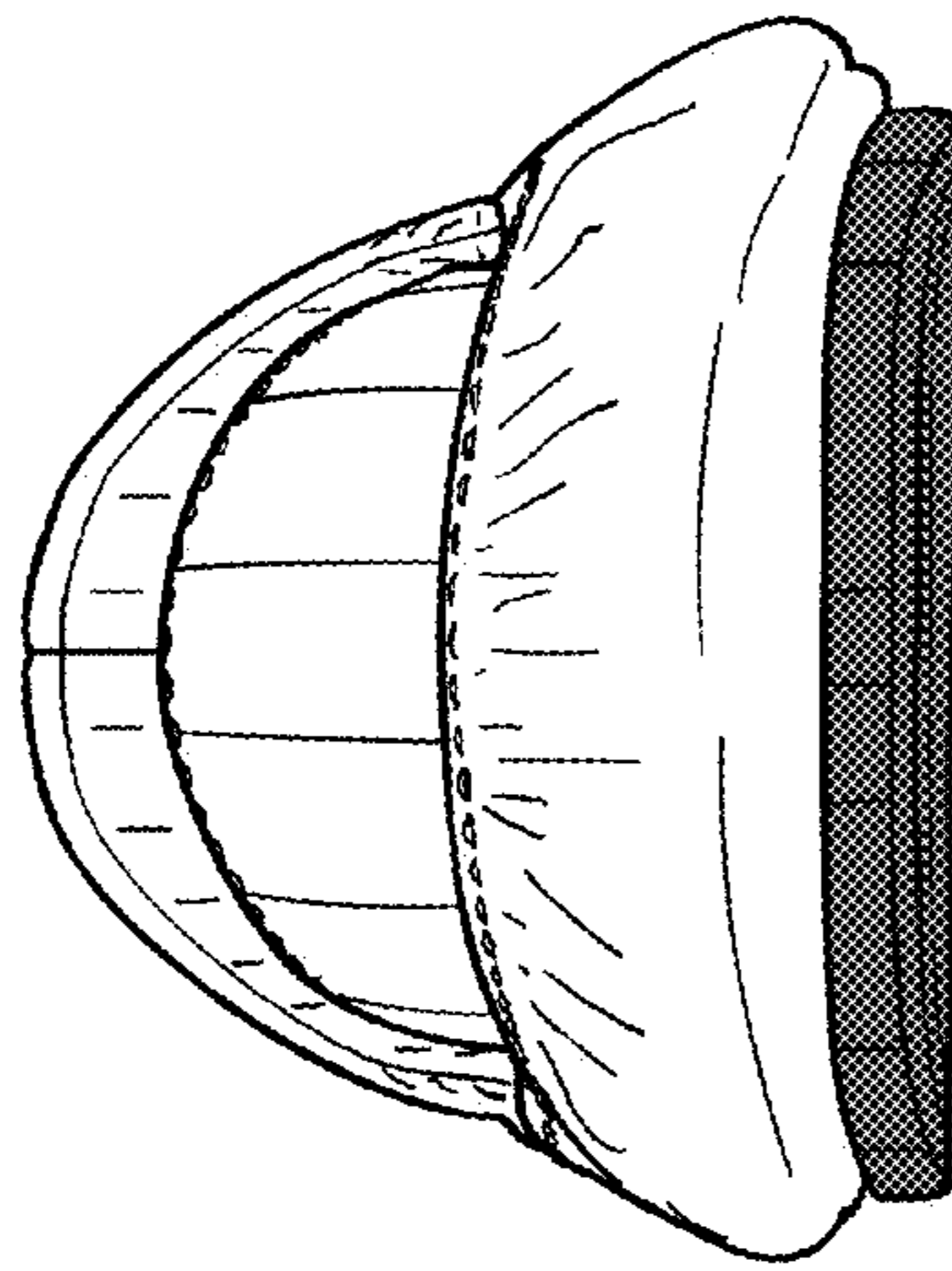

FIG. 34

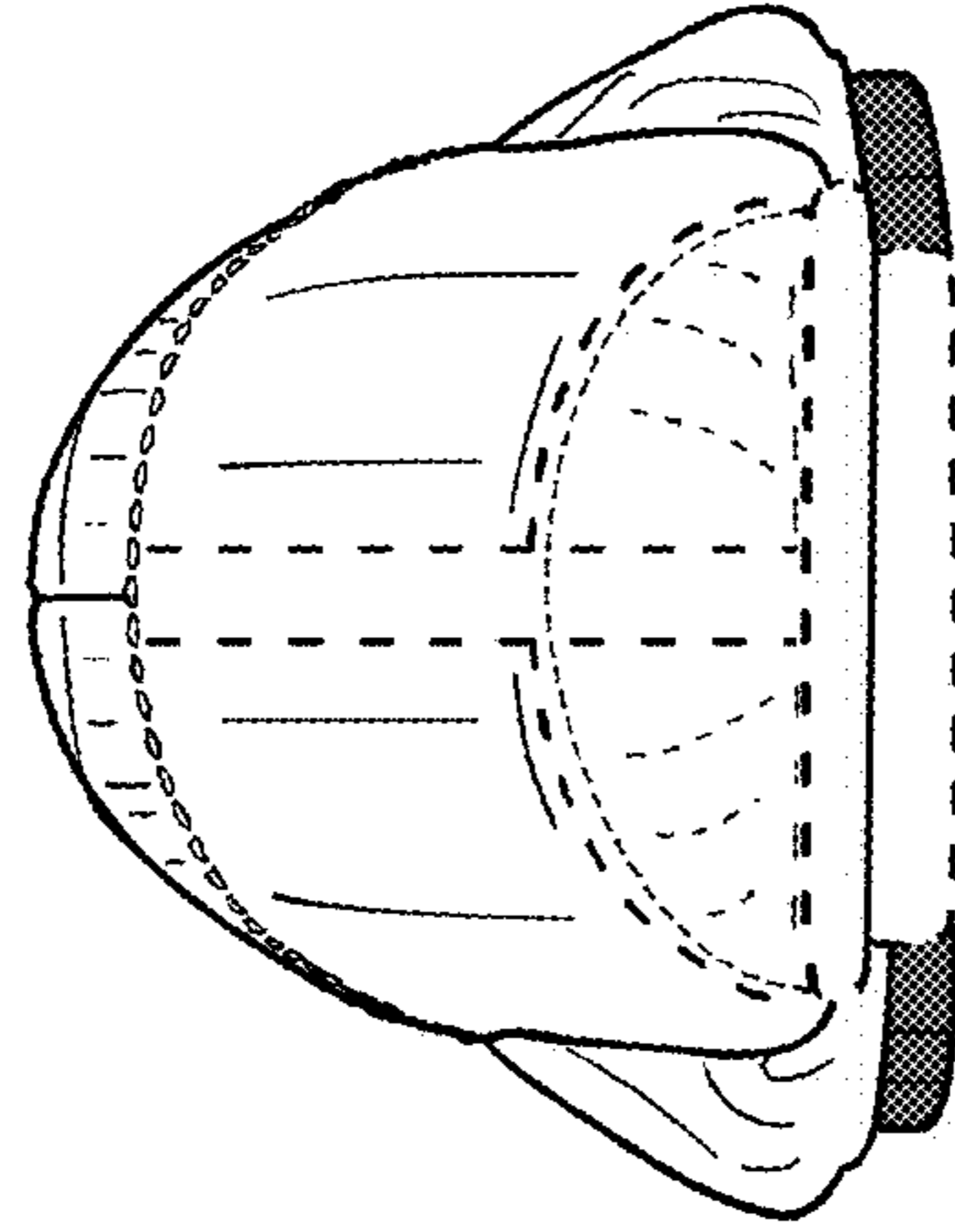

FIG. 35

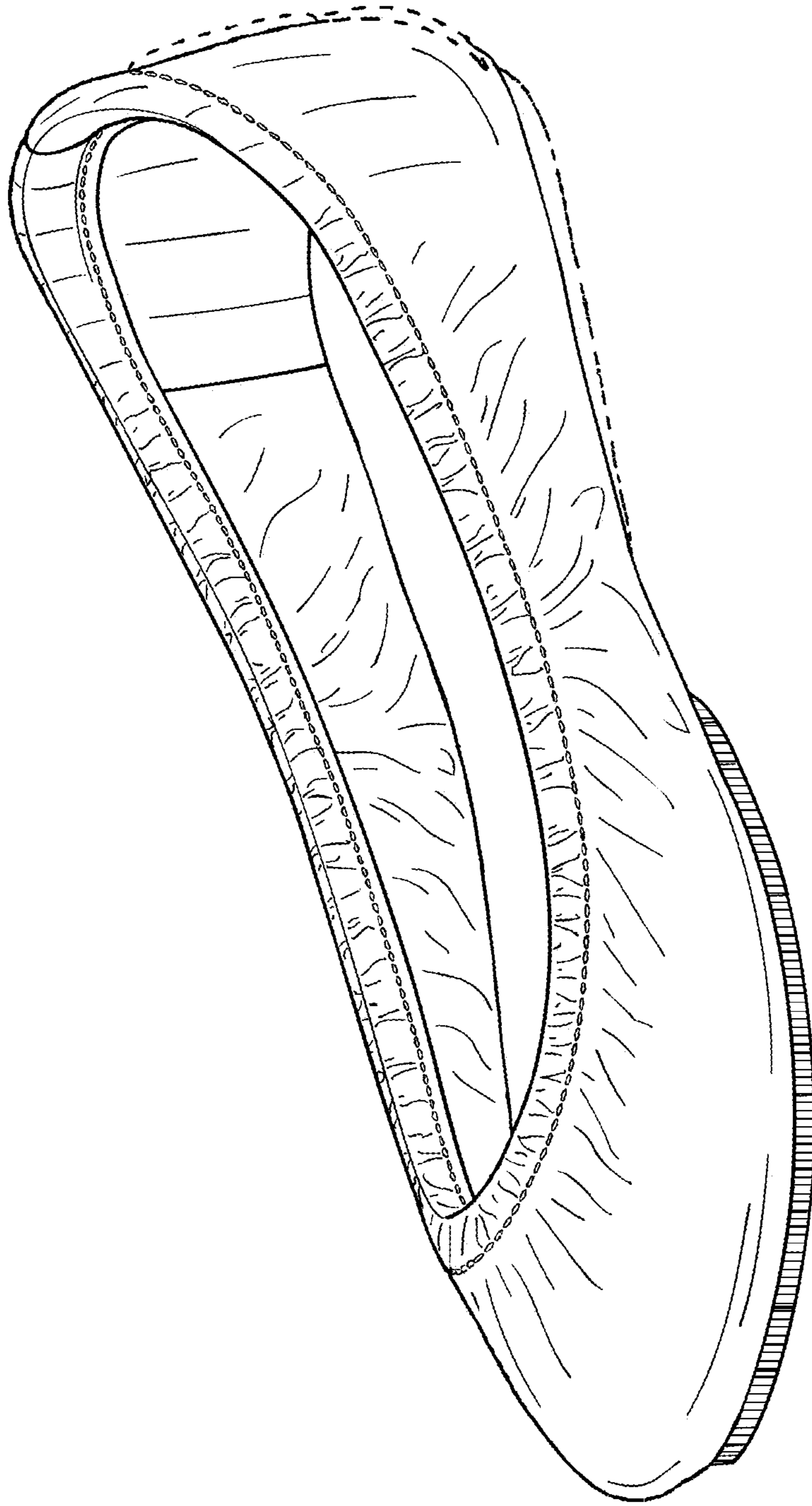

FIG. 36

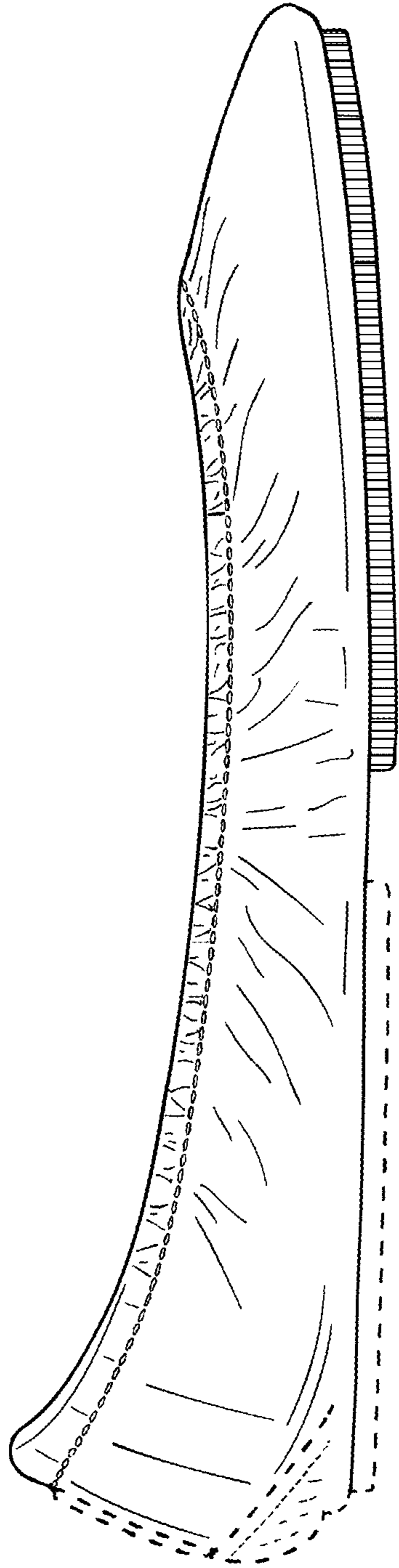

FIG. 37

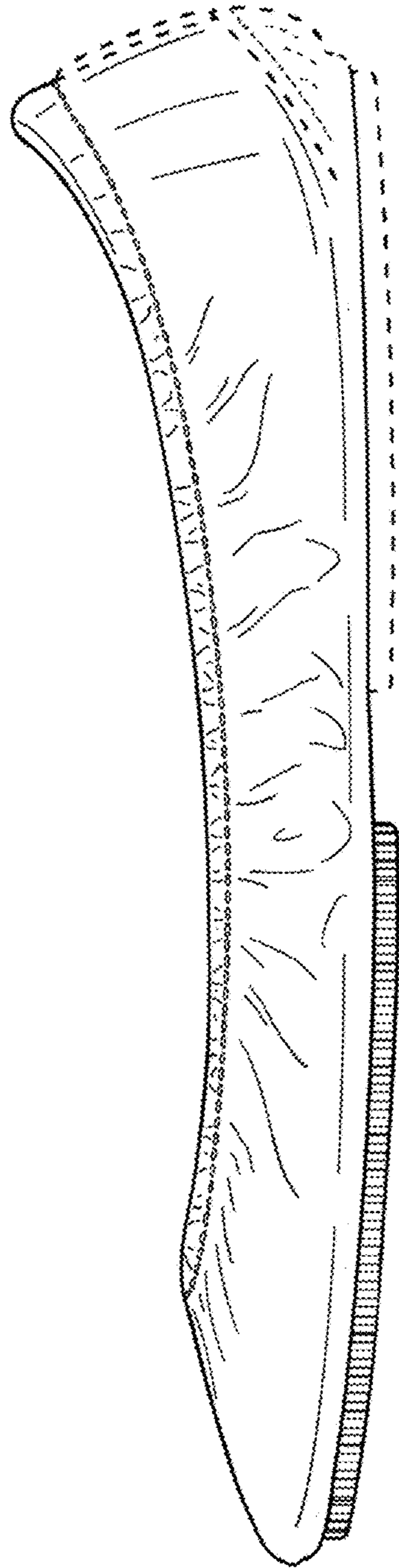

FIG. 38

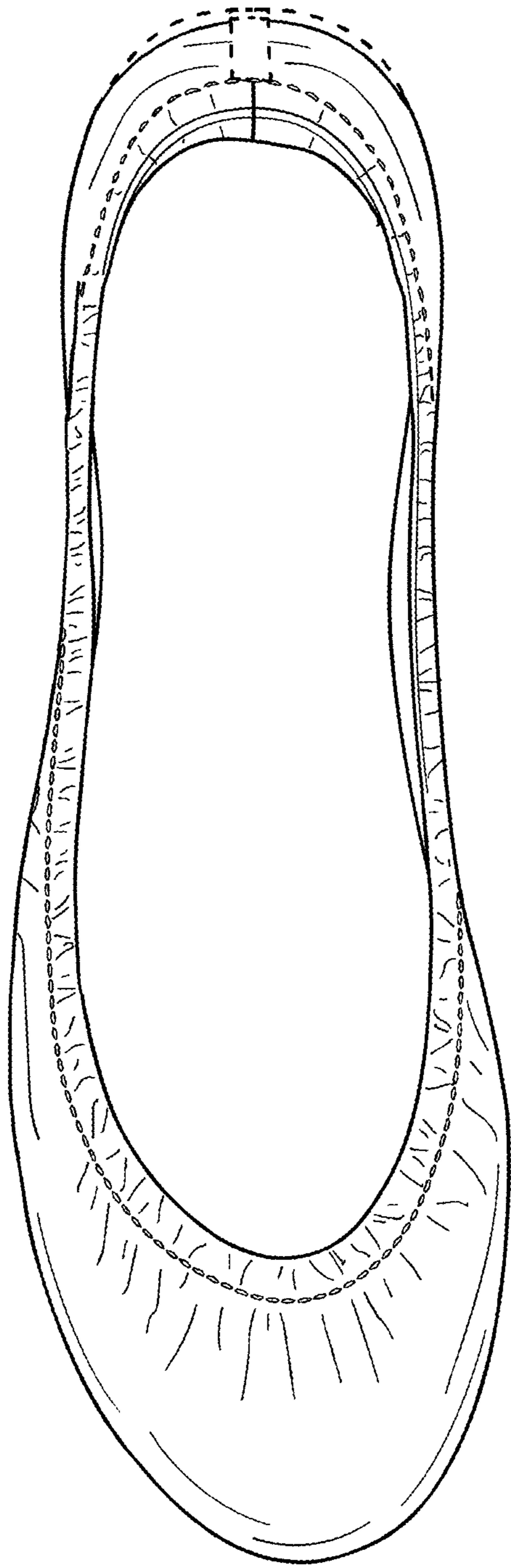

FIG. 39

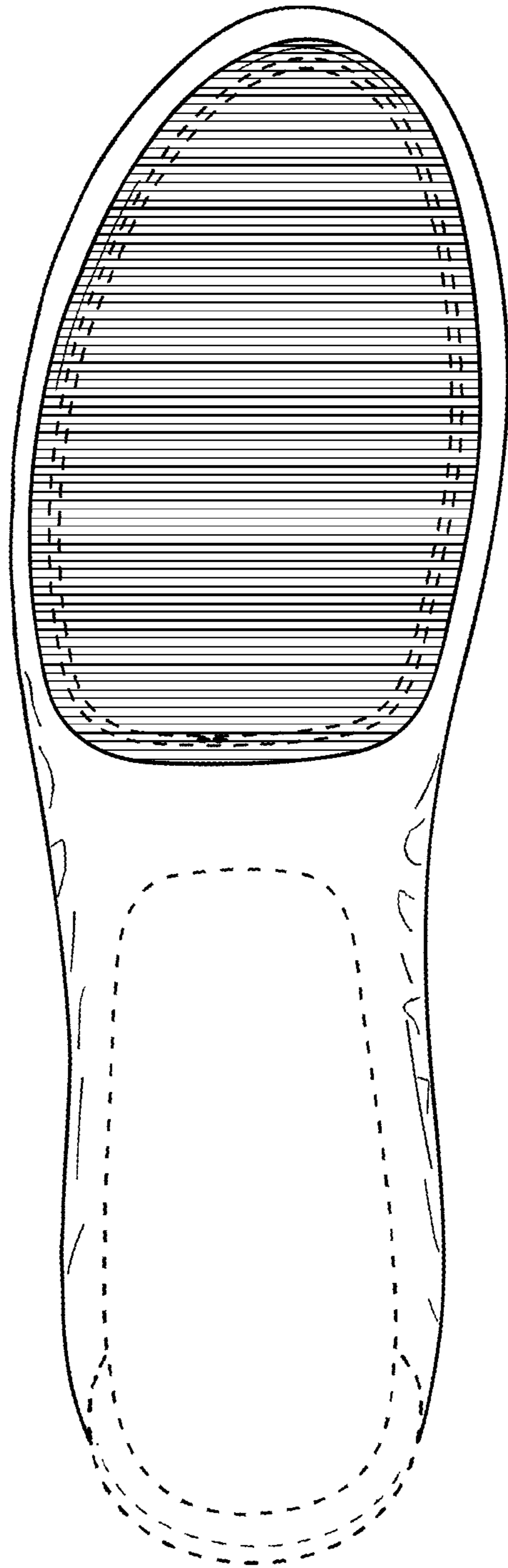

FIG. 40

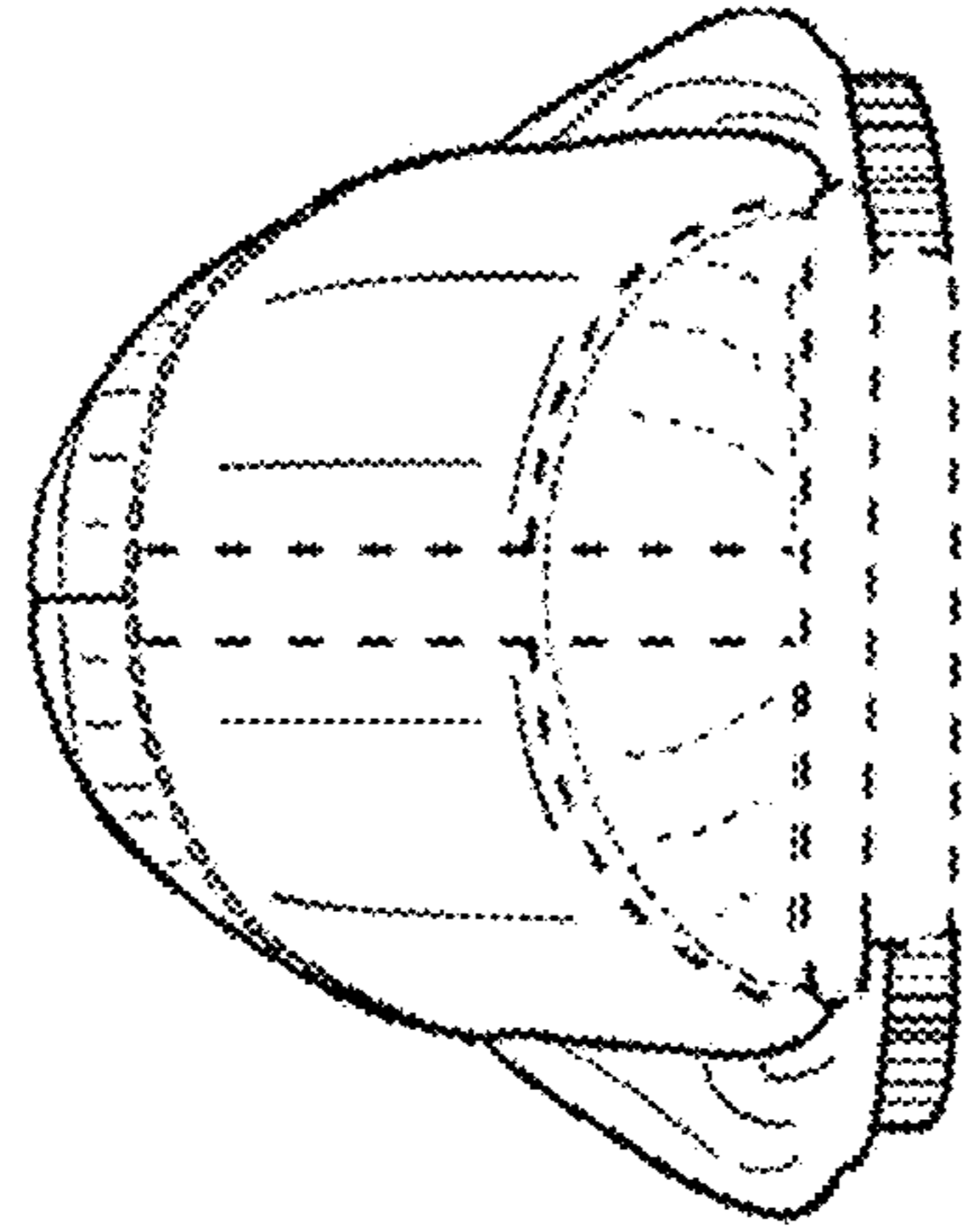

FIG. 42

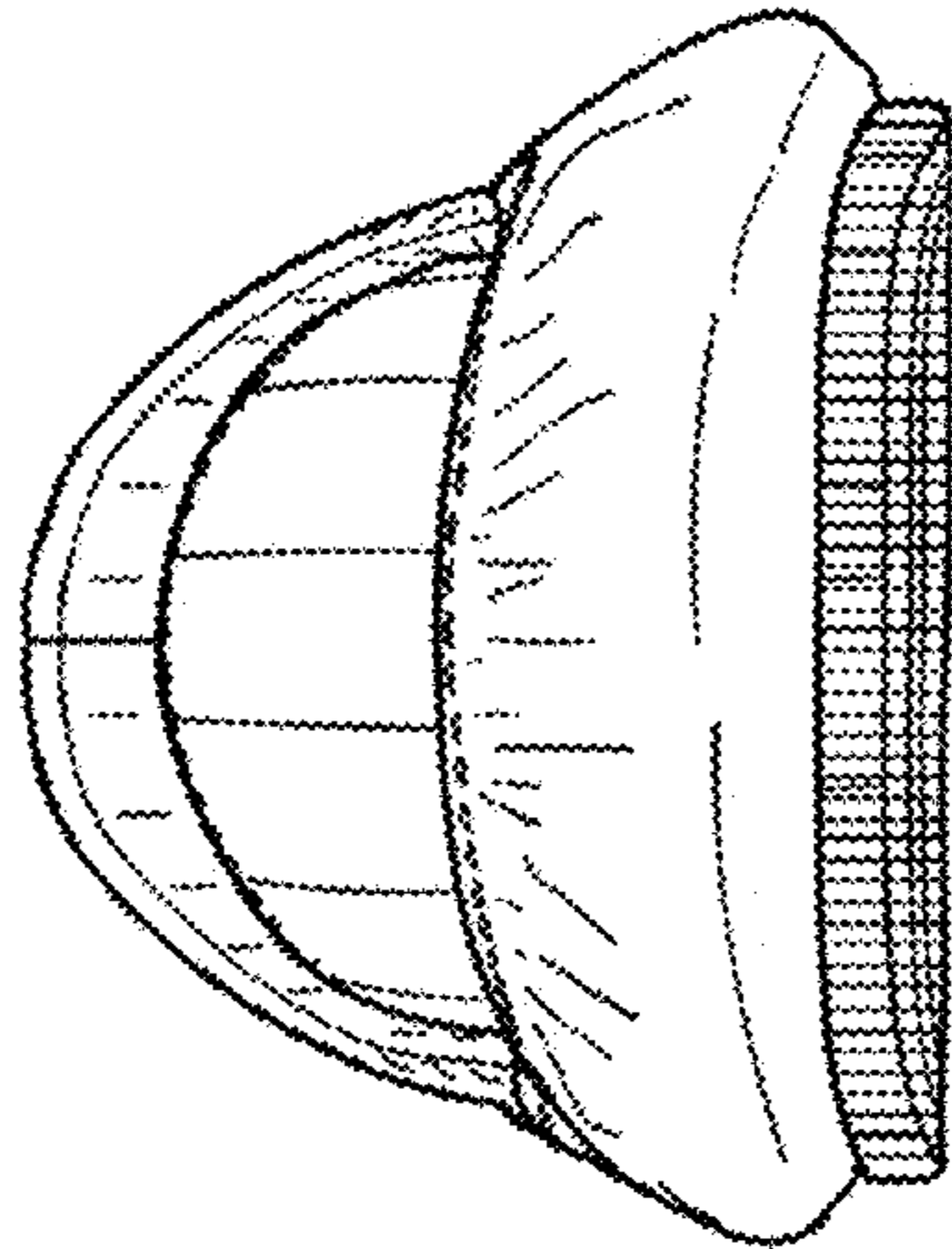

FIG. 41



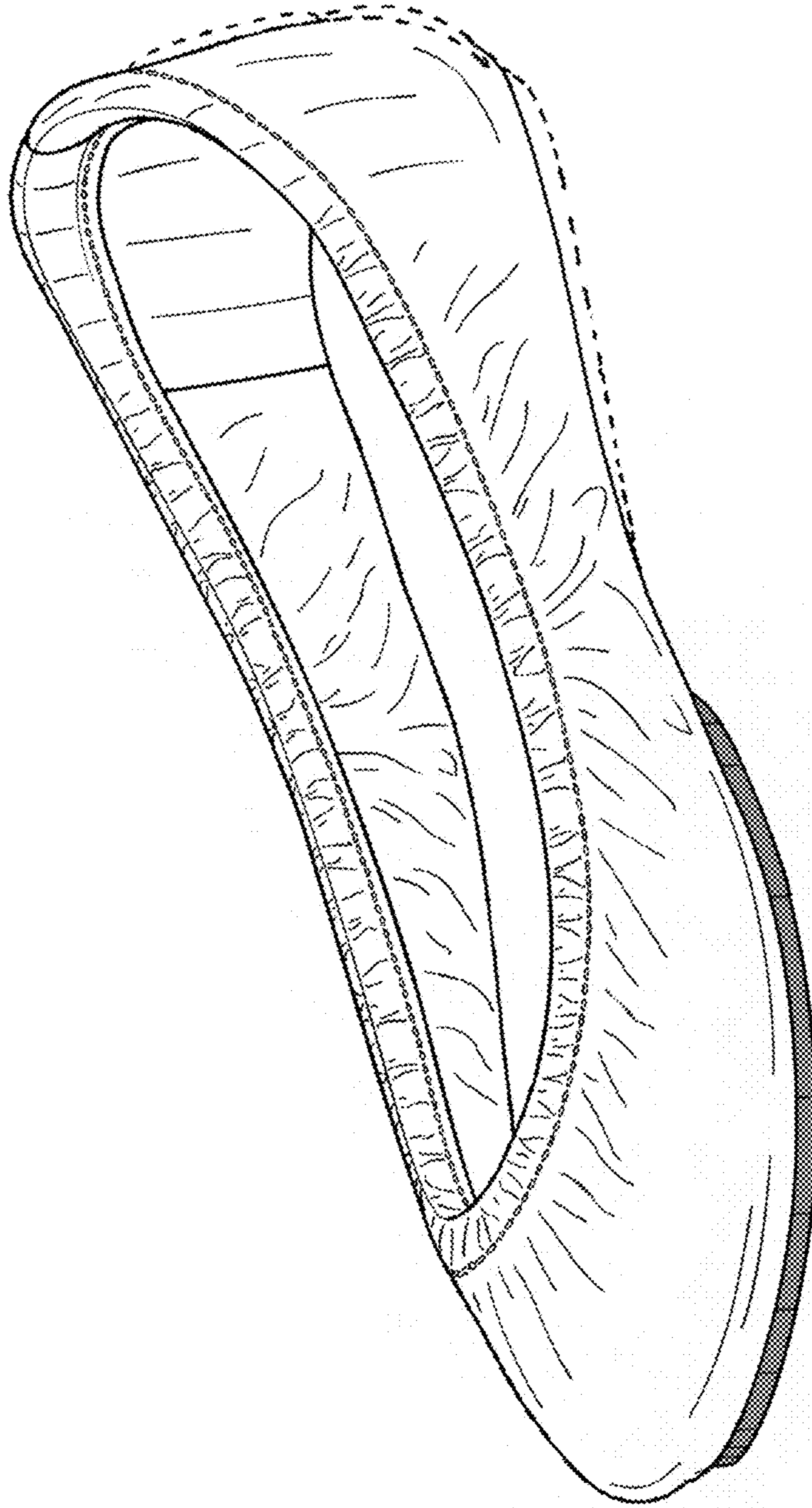

FIG. 43

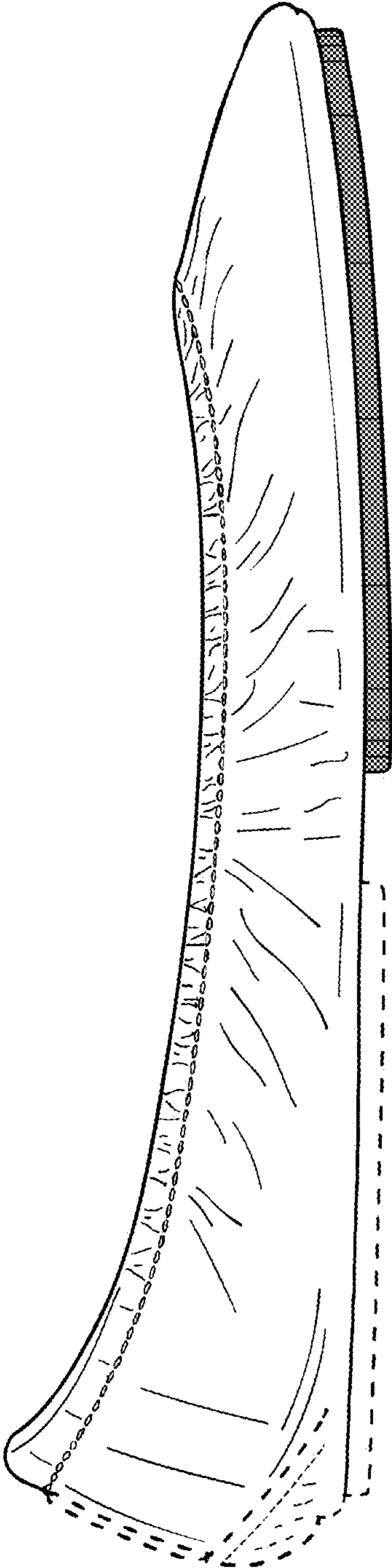

FIG. 44

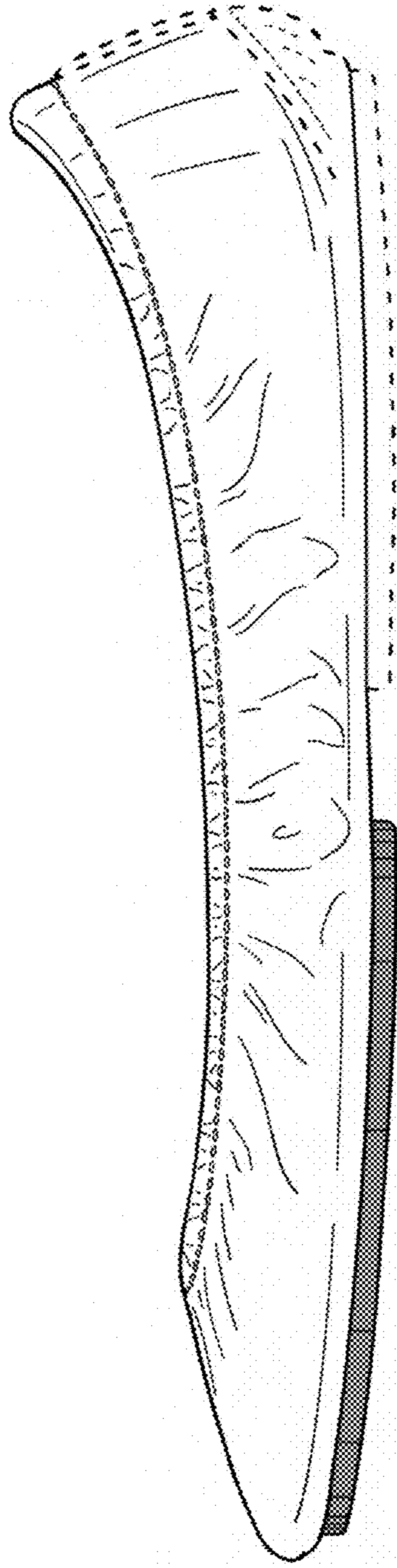

FIG. 45

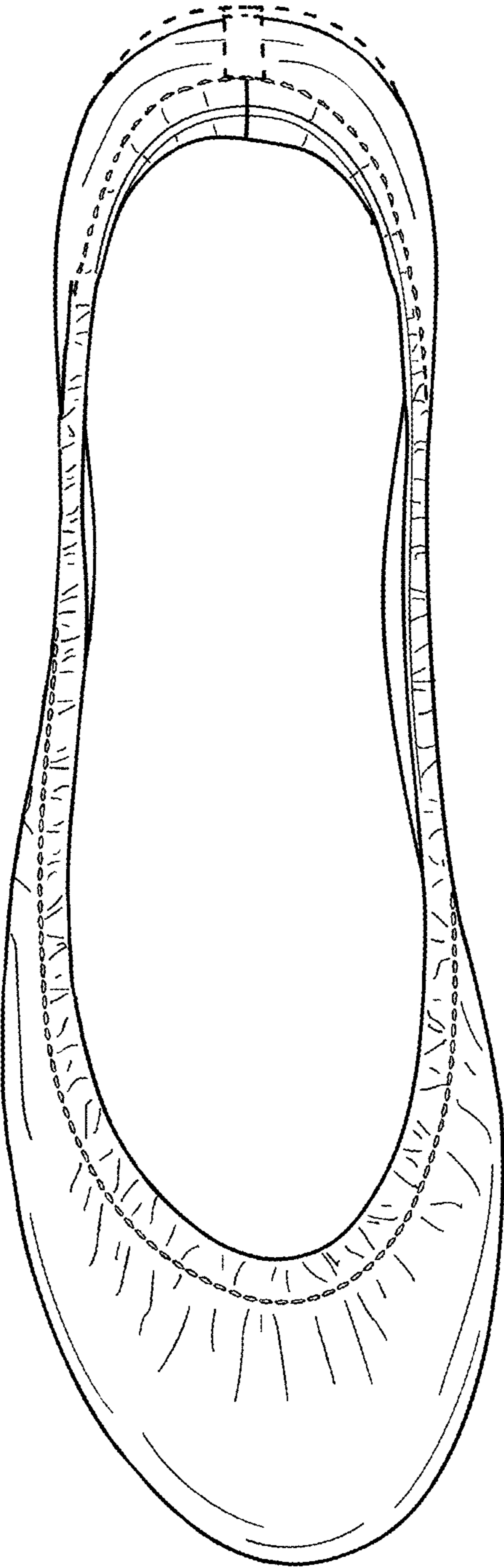

FIG. 46

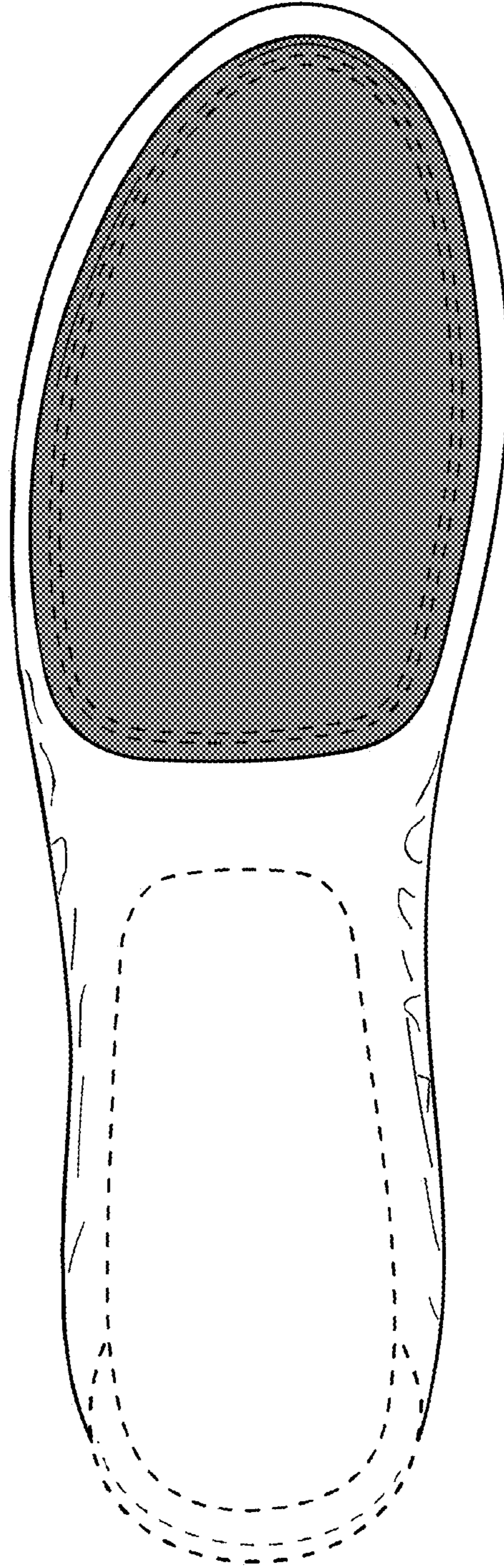

FIG. 47

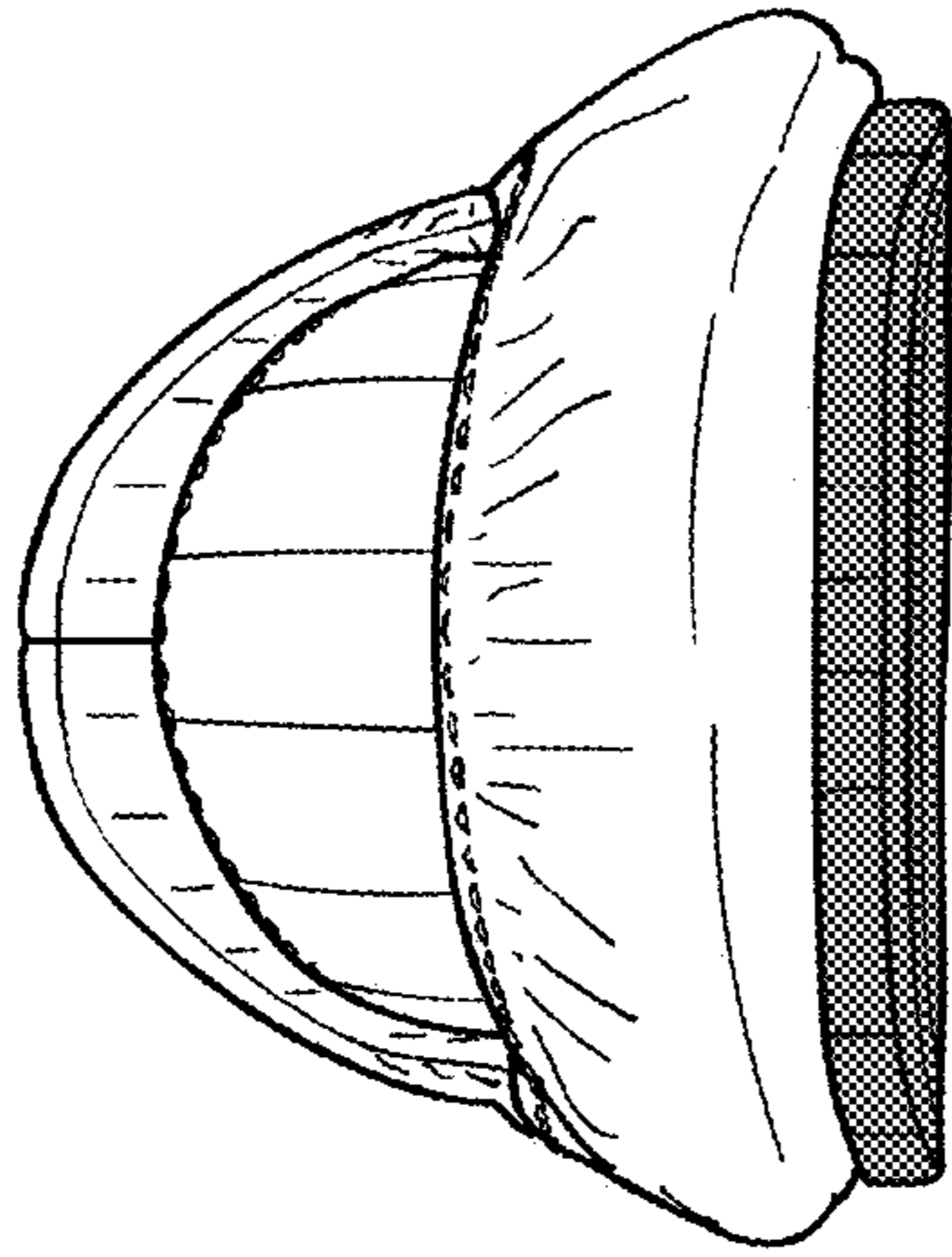

FIG. 48

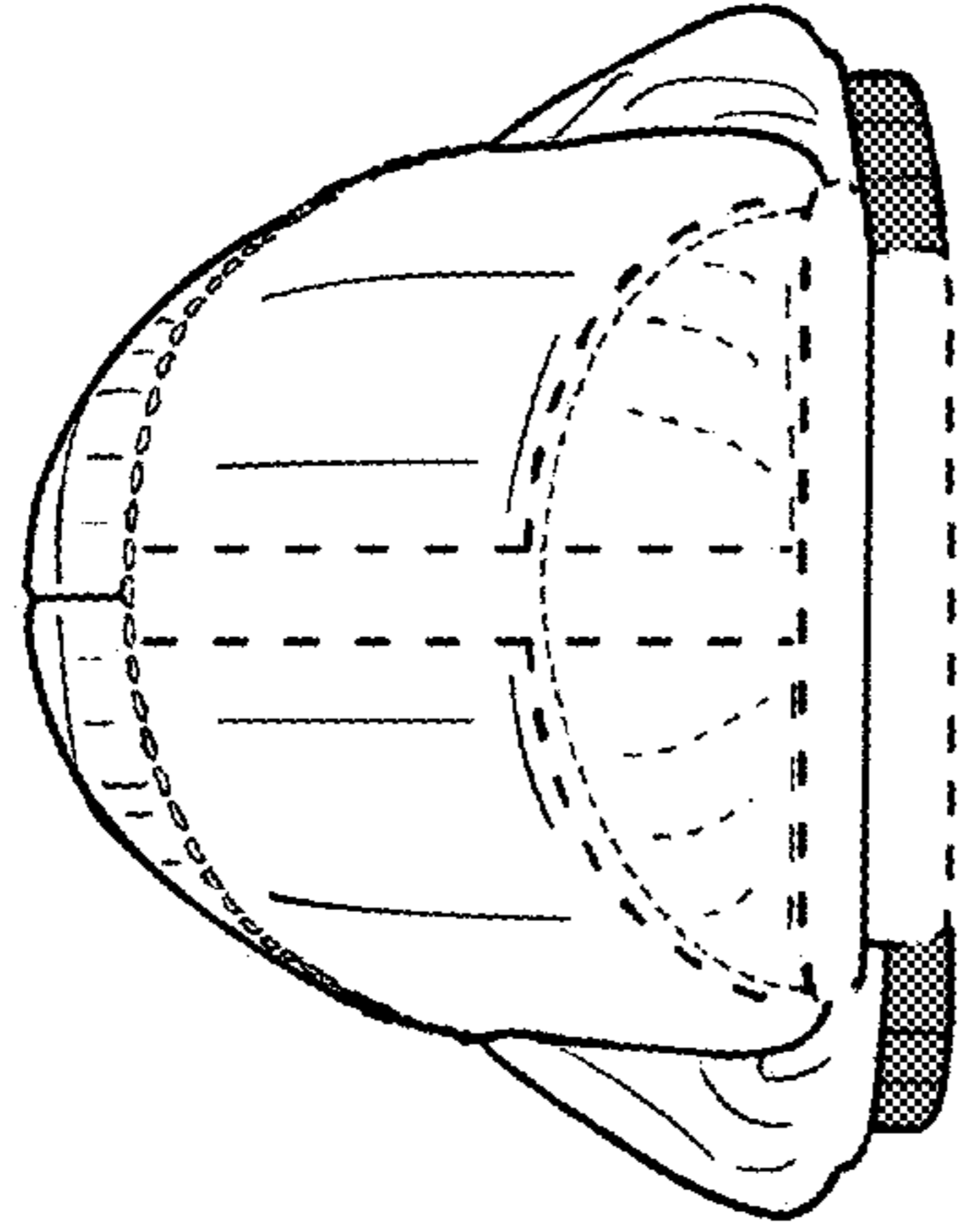

FIG. 49

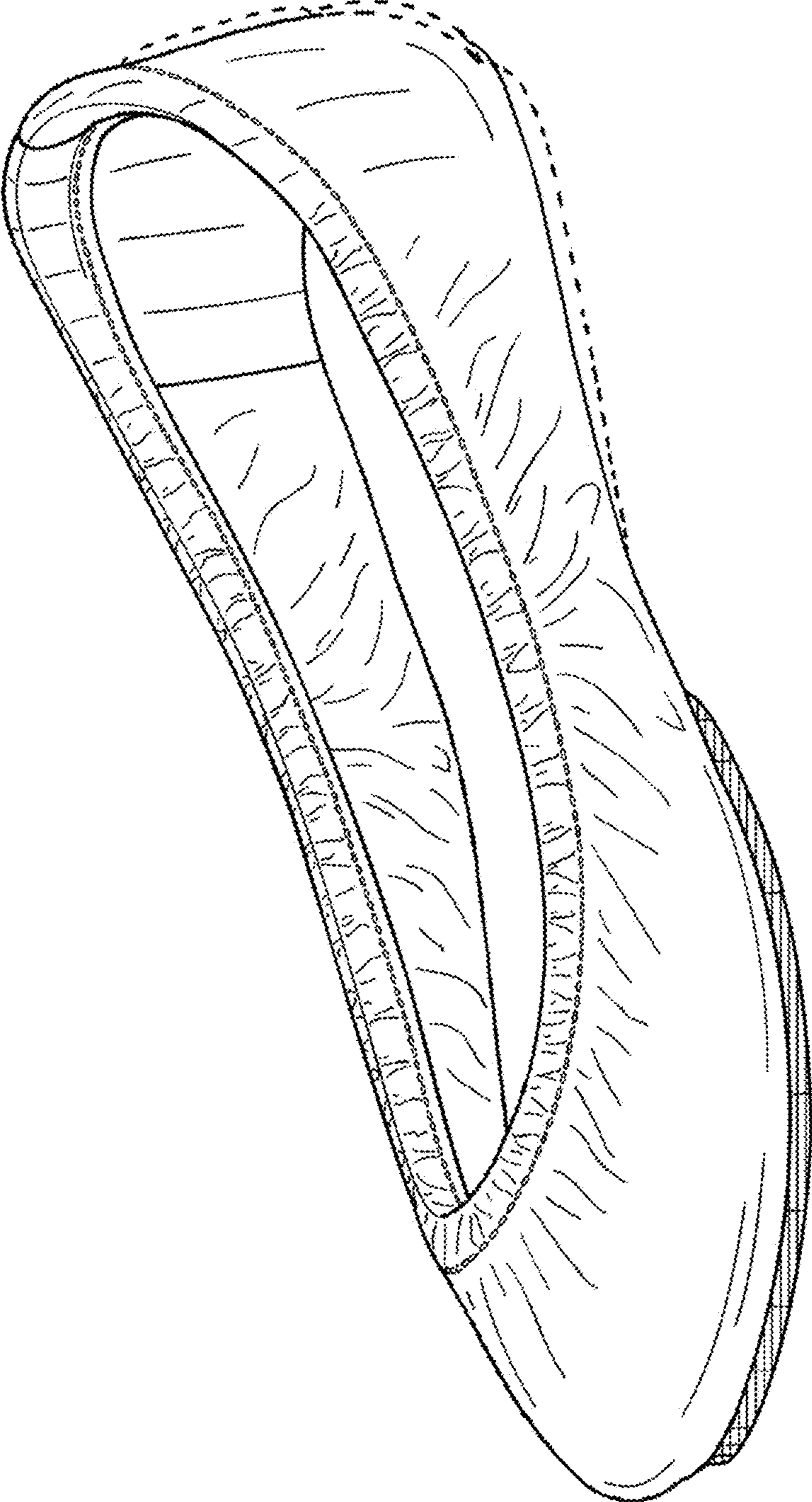

FIG. 50

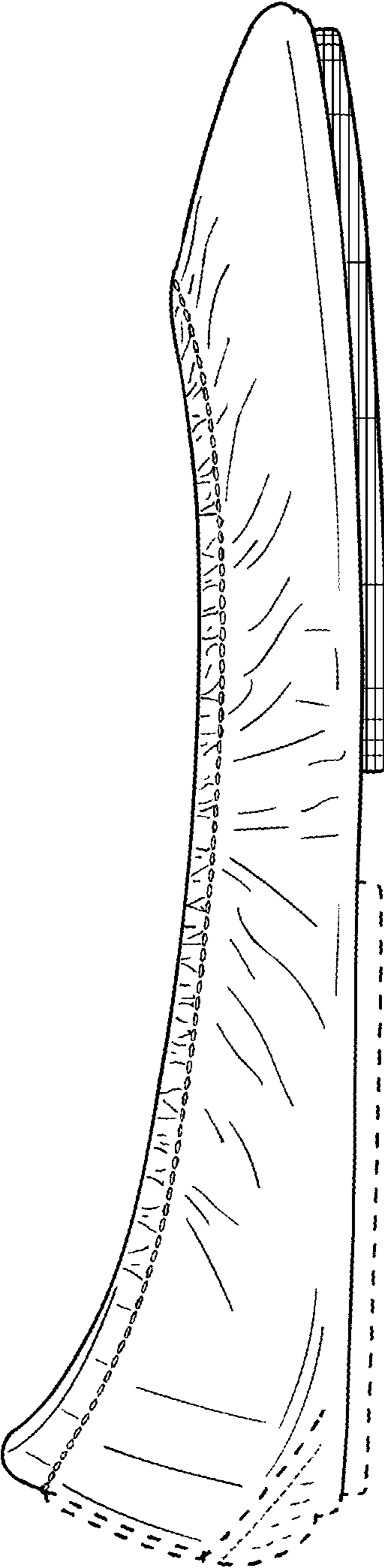

FIG. 51



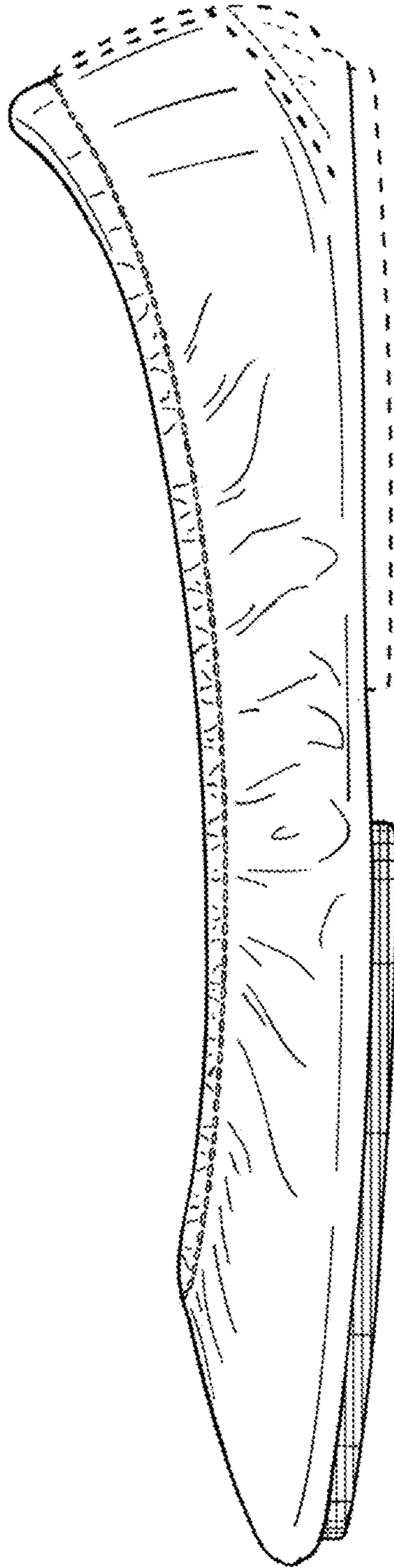

FIG. 52

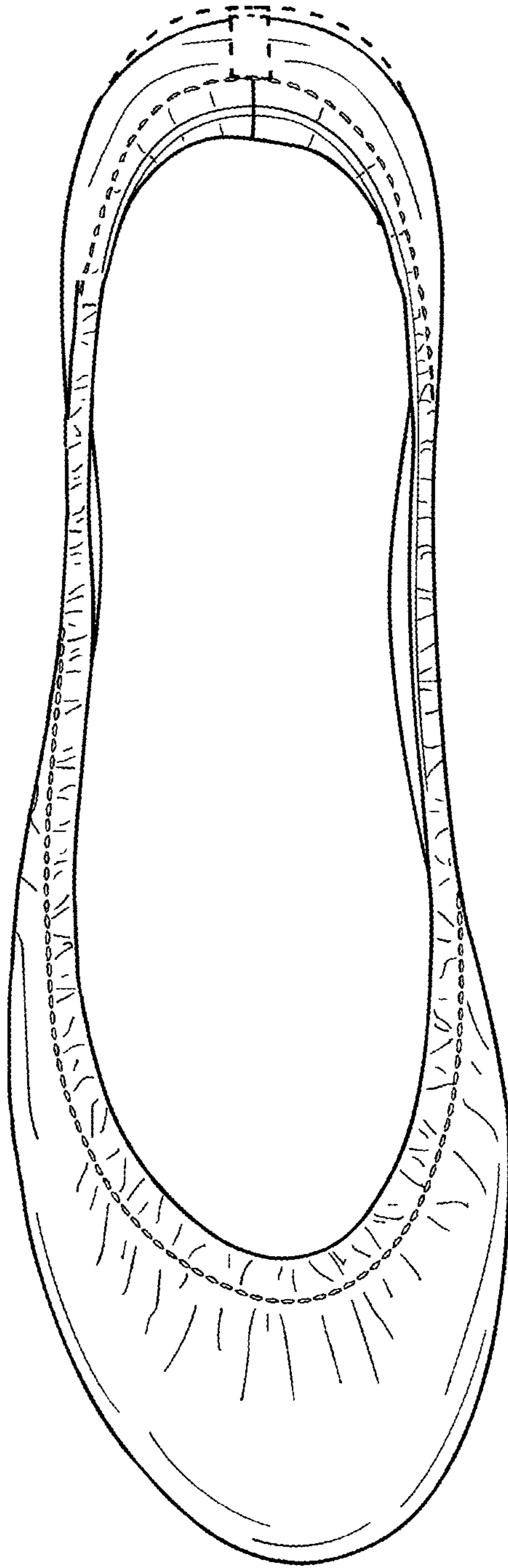

FIG. 53

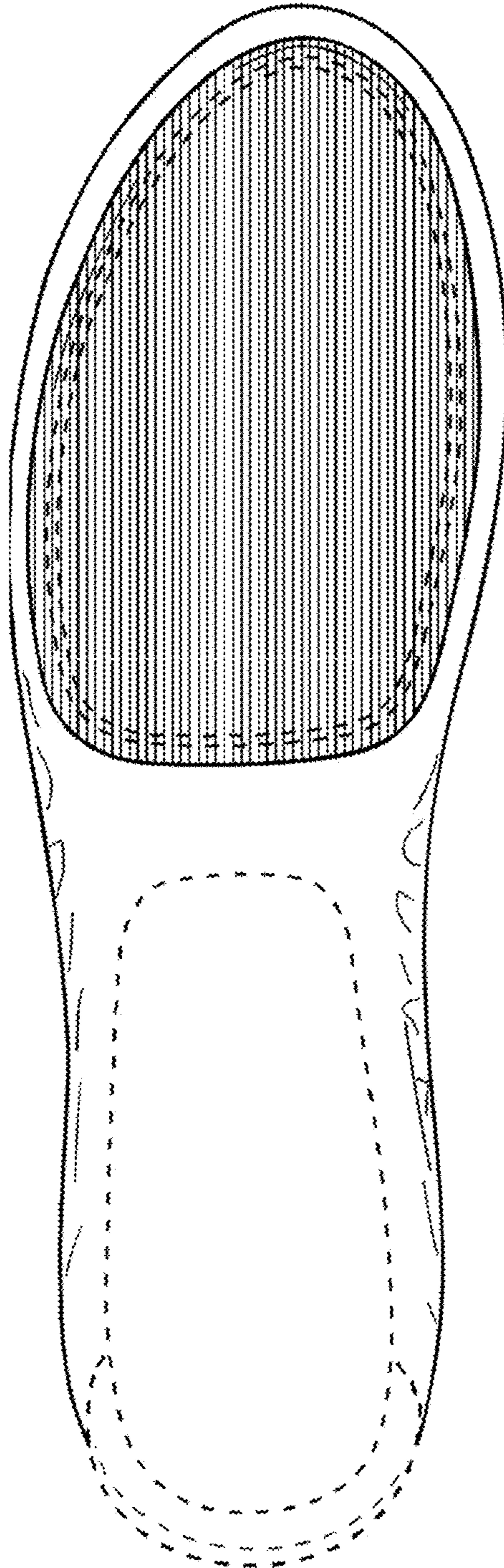

FIG. 54

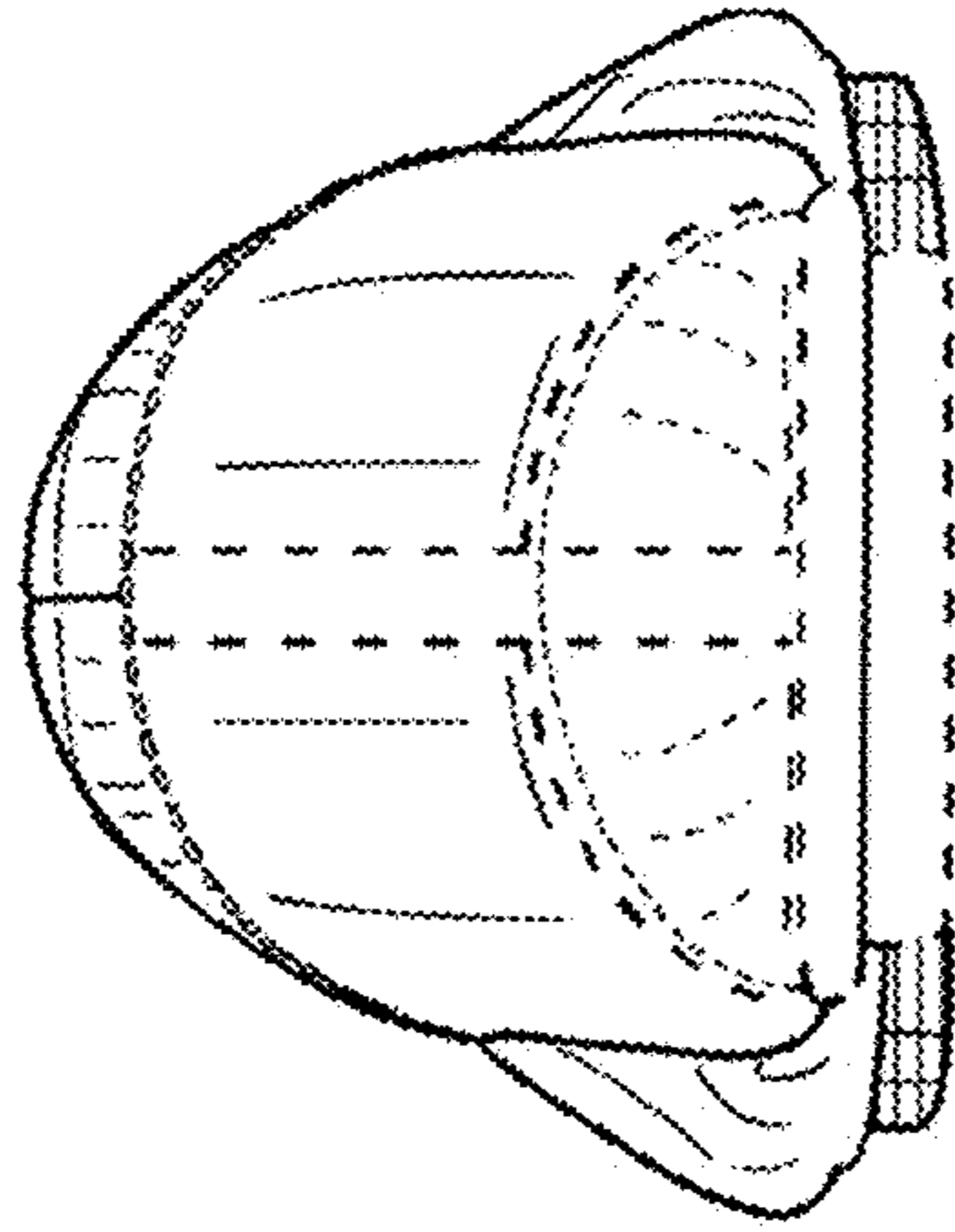

FIG. 55

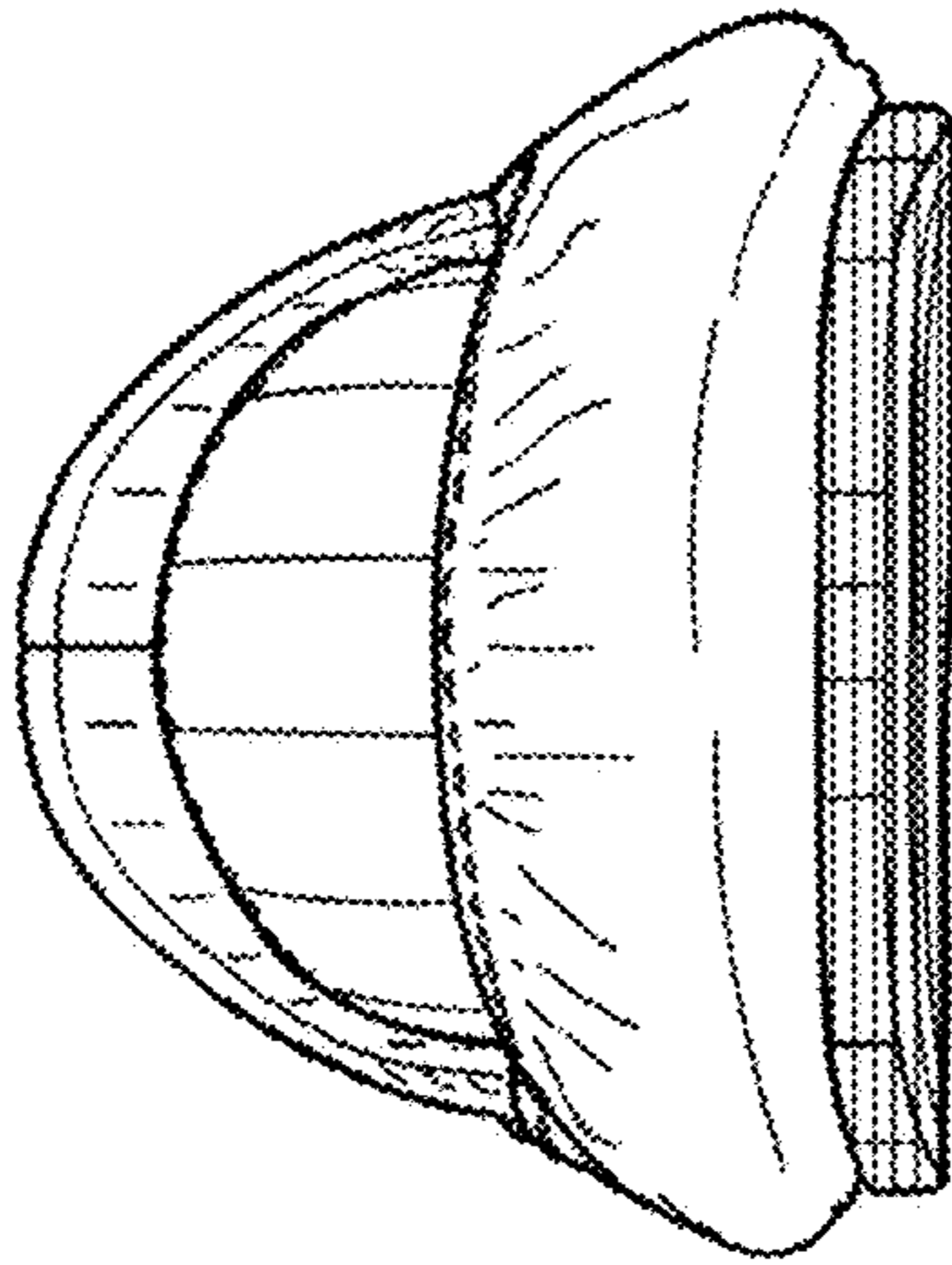

FIG. 56

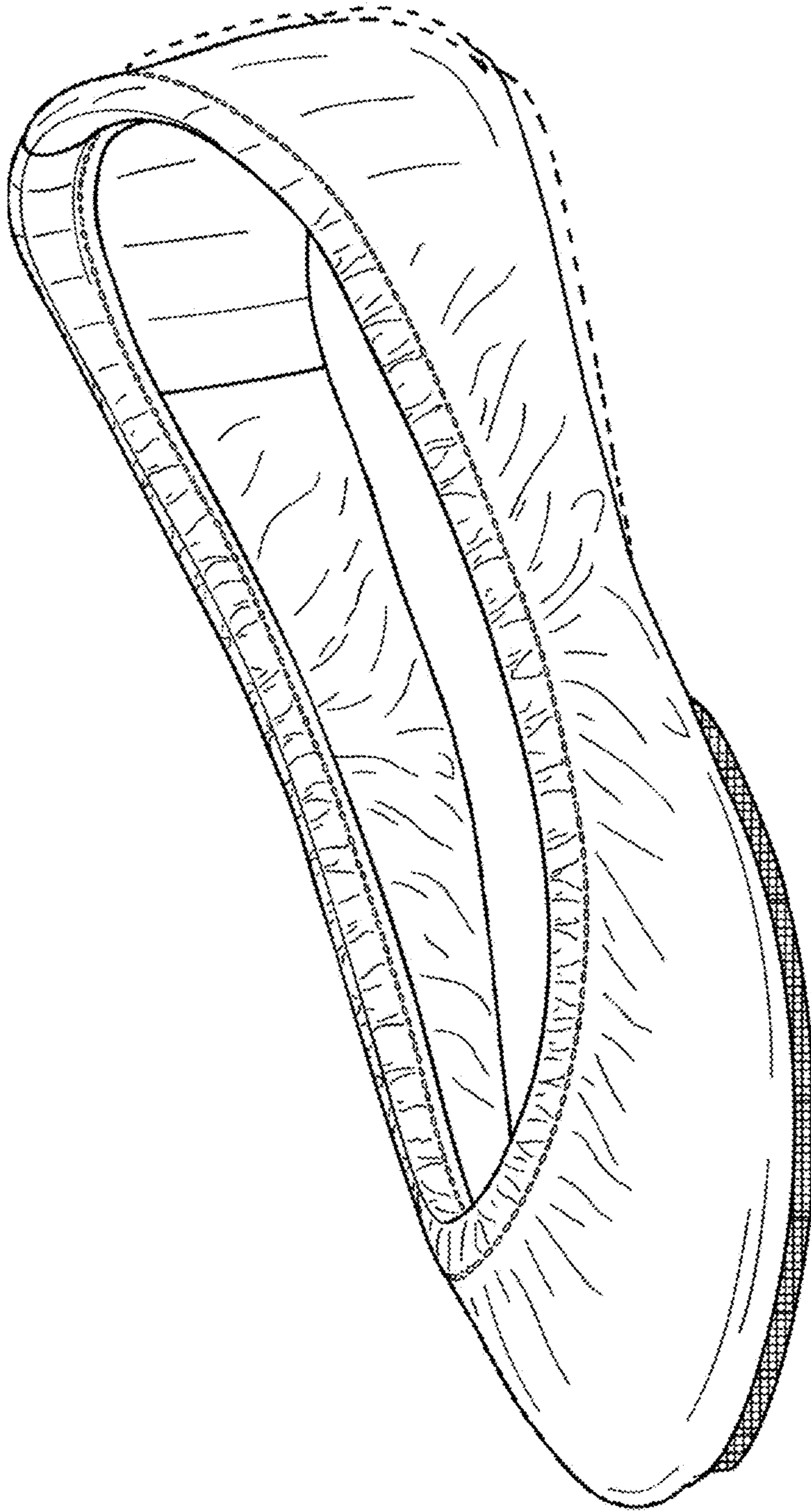

FIG. 57

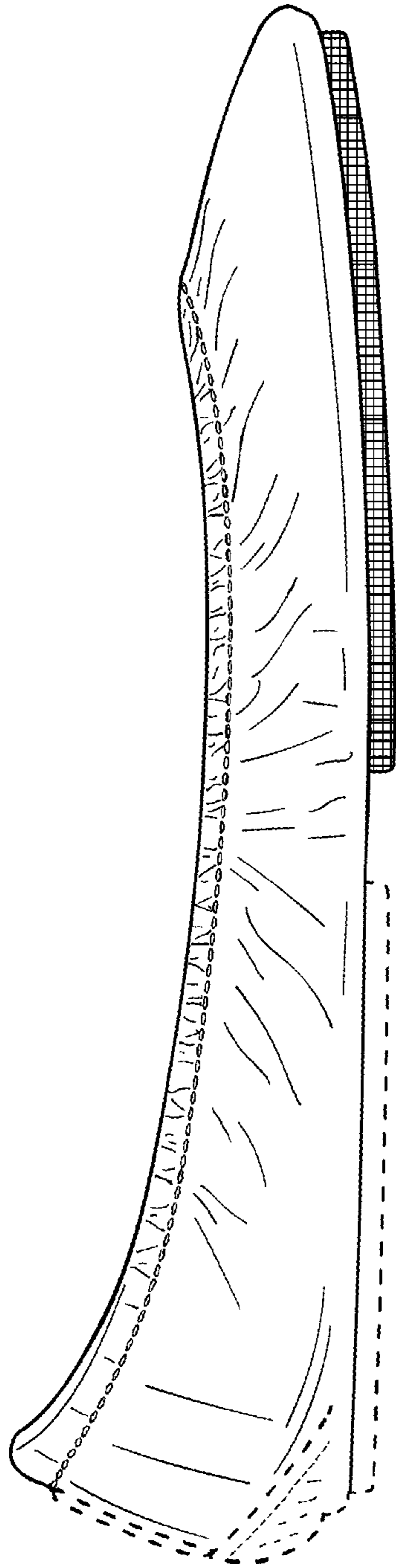

FIG. 58

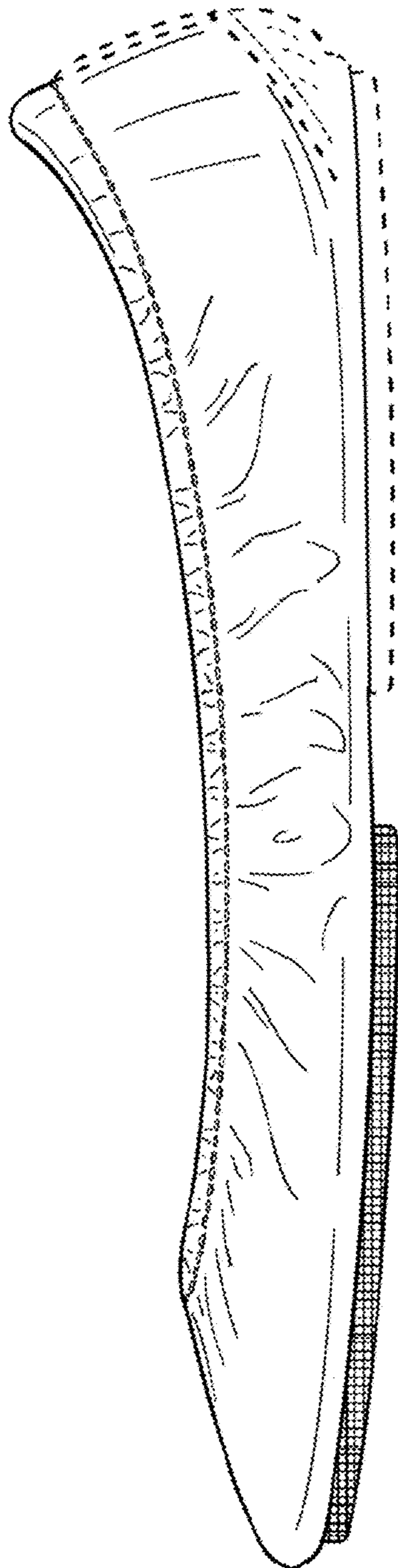

FIG. 59

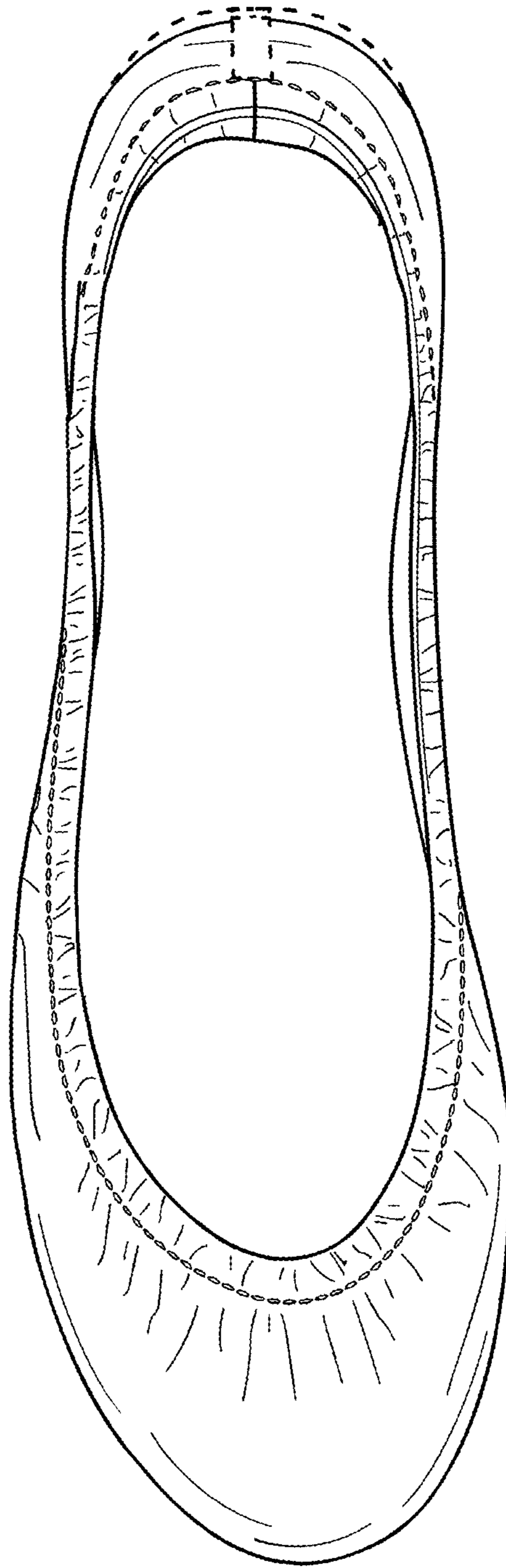

FIG. 60



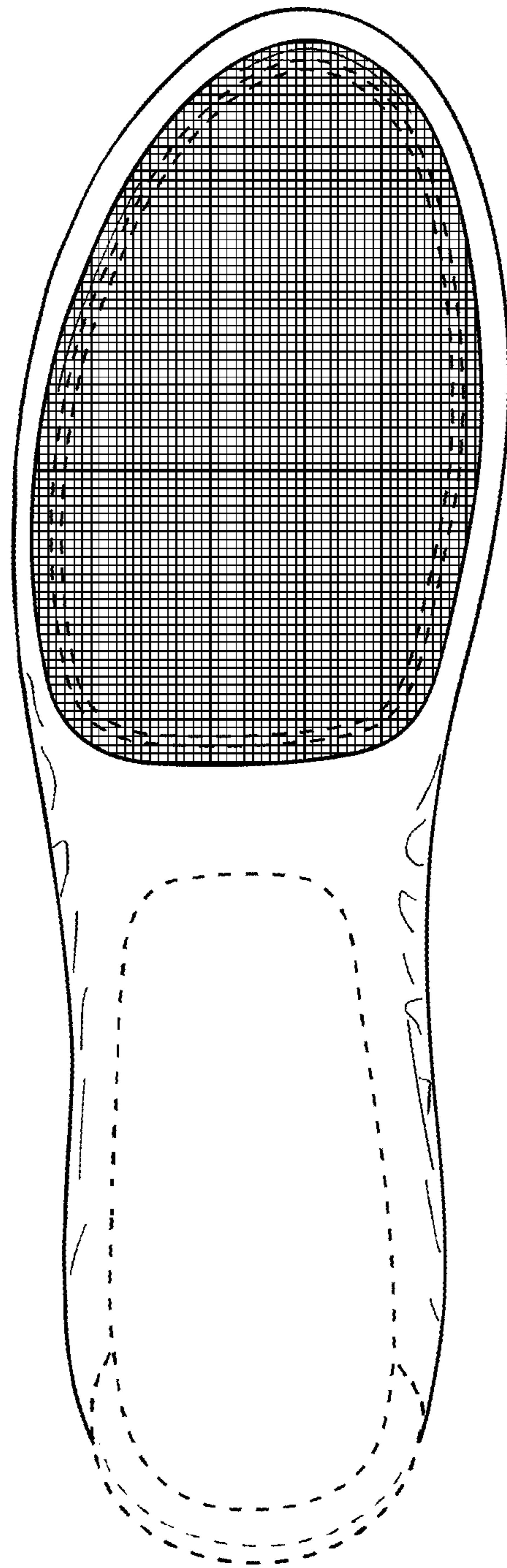

FIG. 61

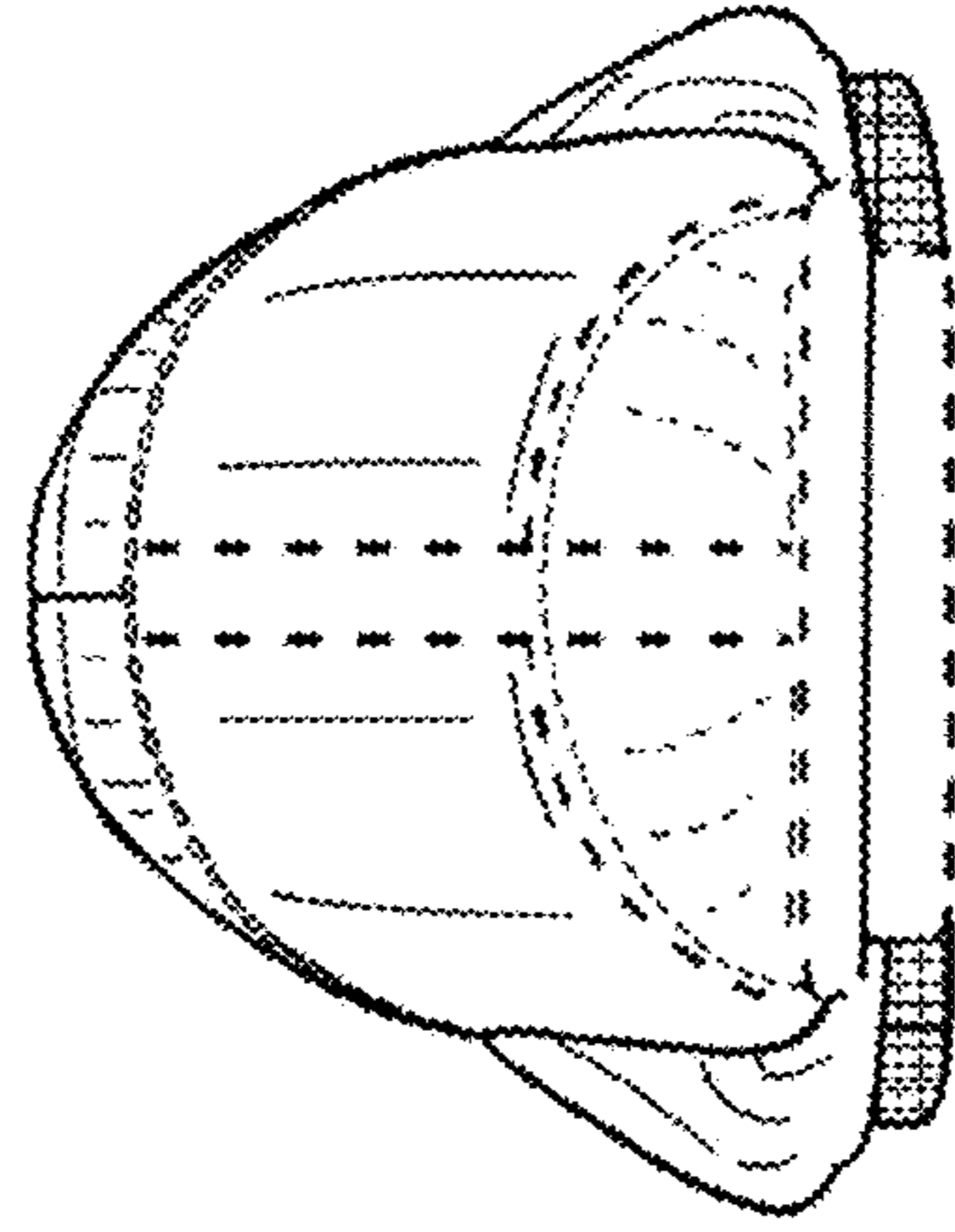

FIG. 62

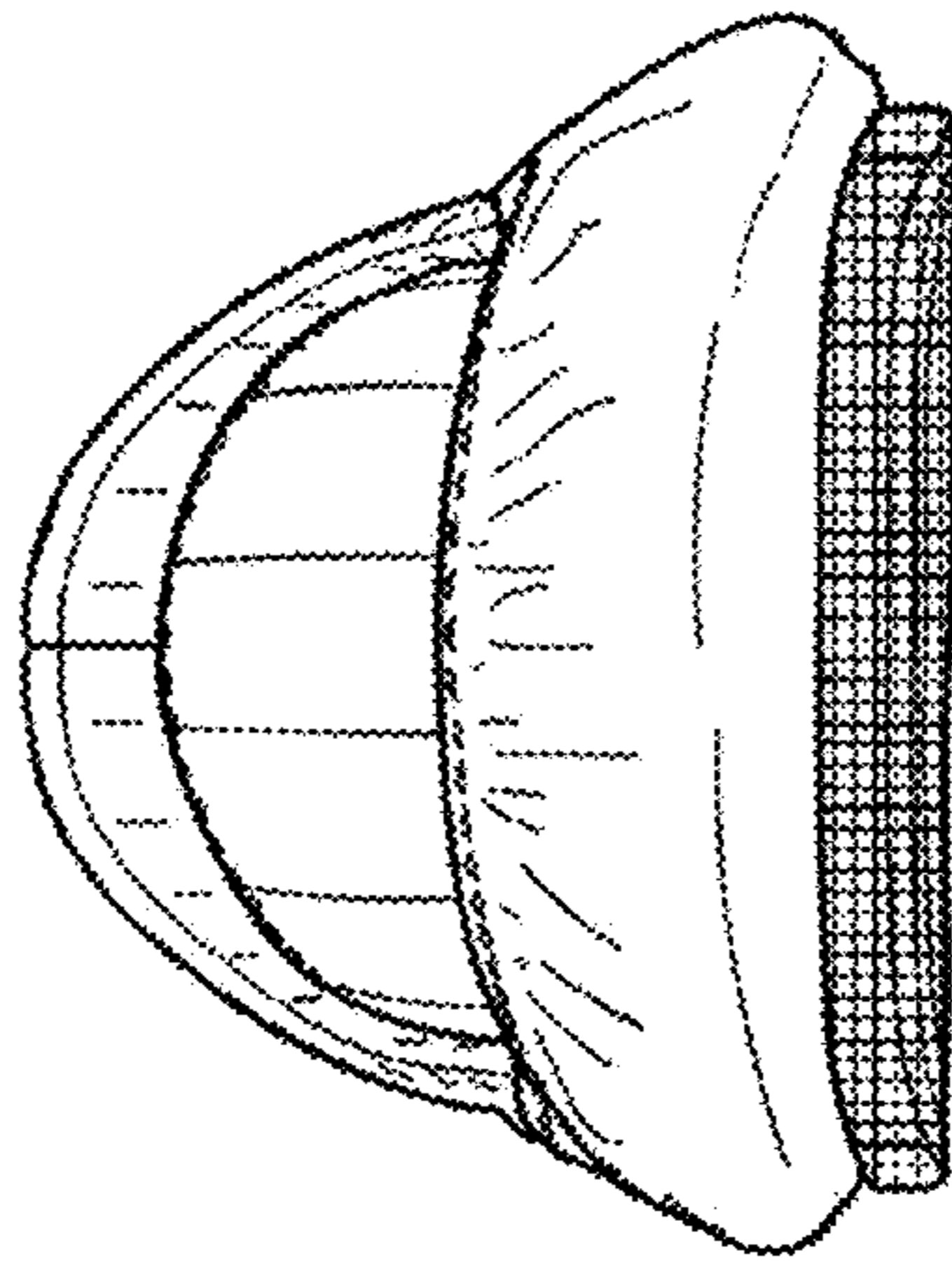

FIG. 63

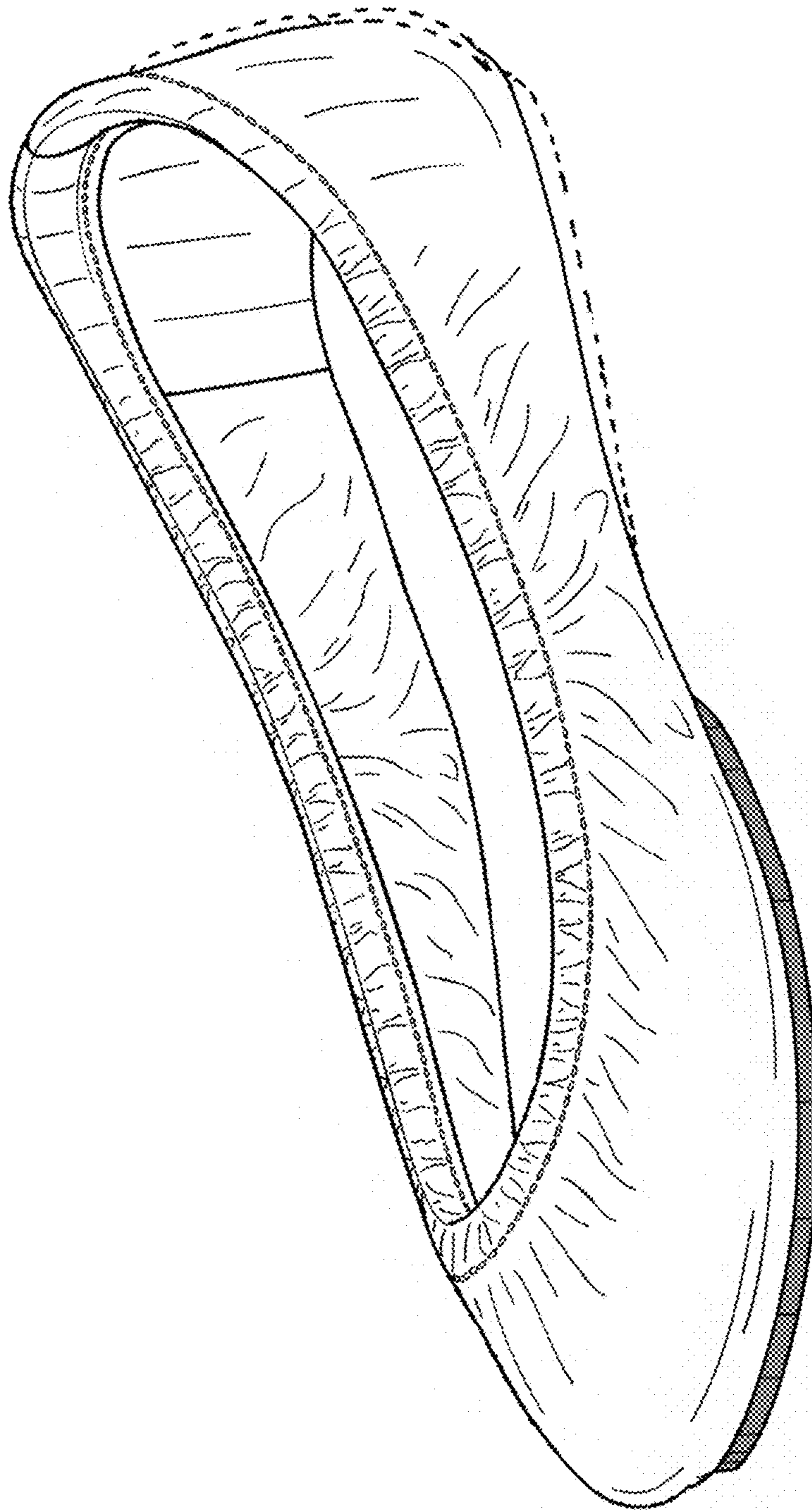

FIG. 64

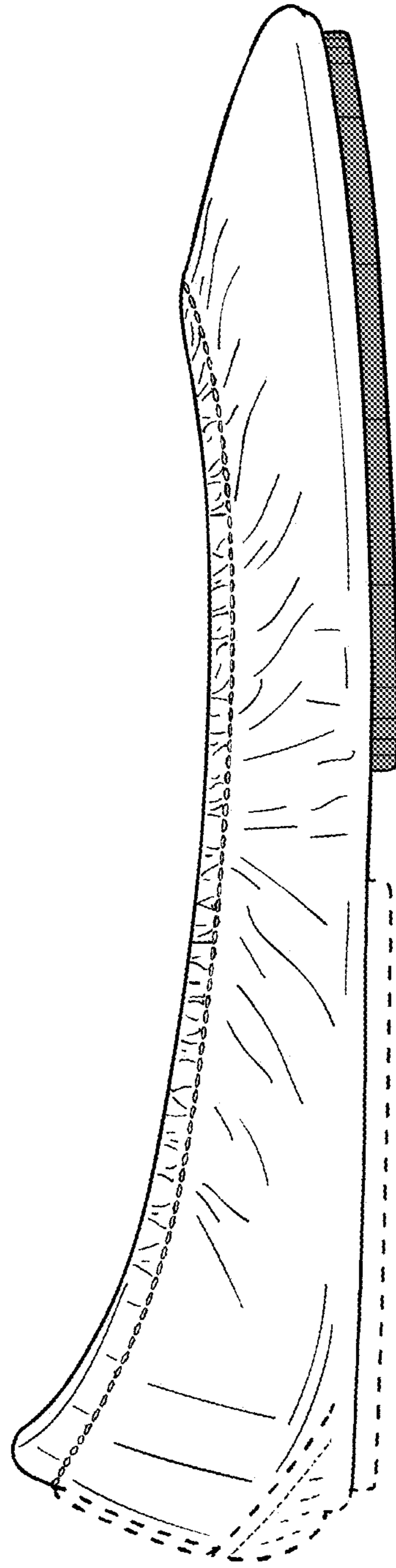

FIG. 65

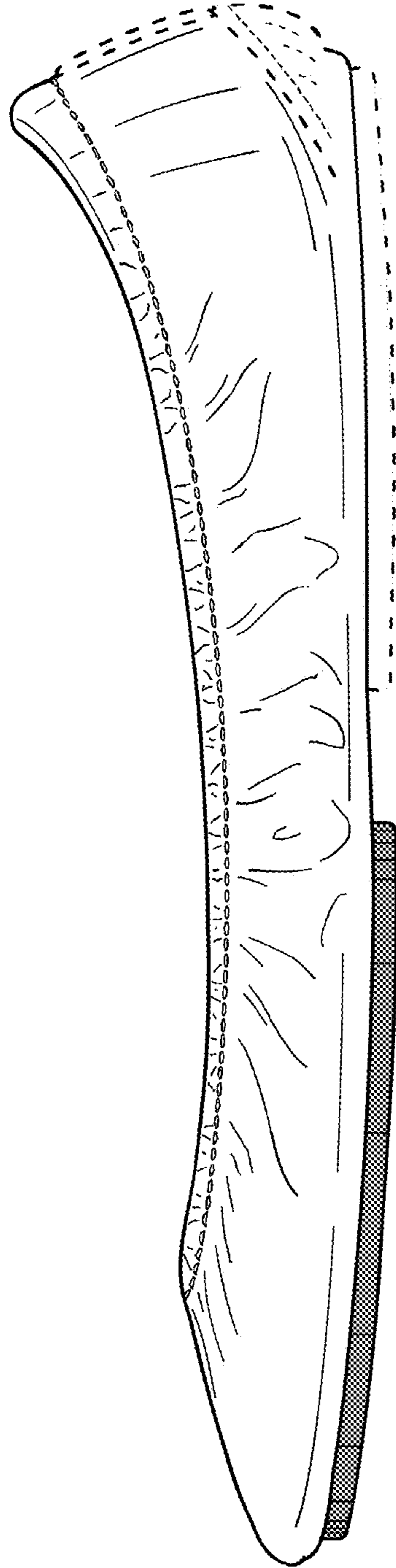

FIG. 66

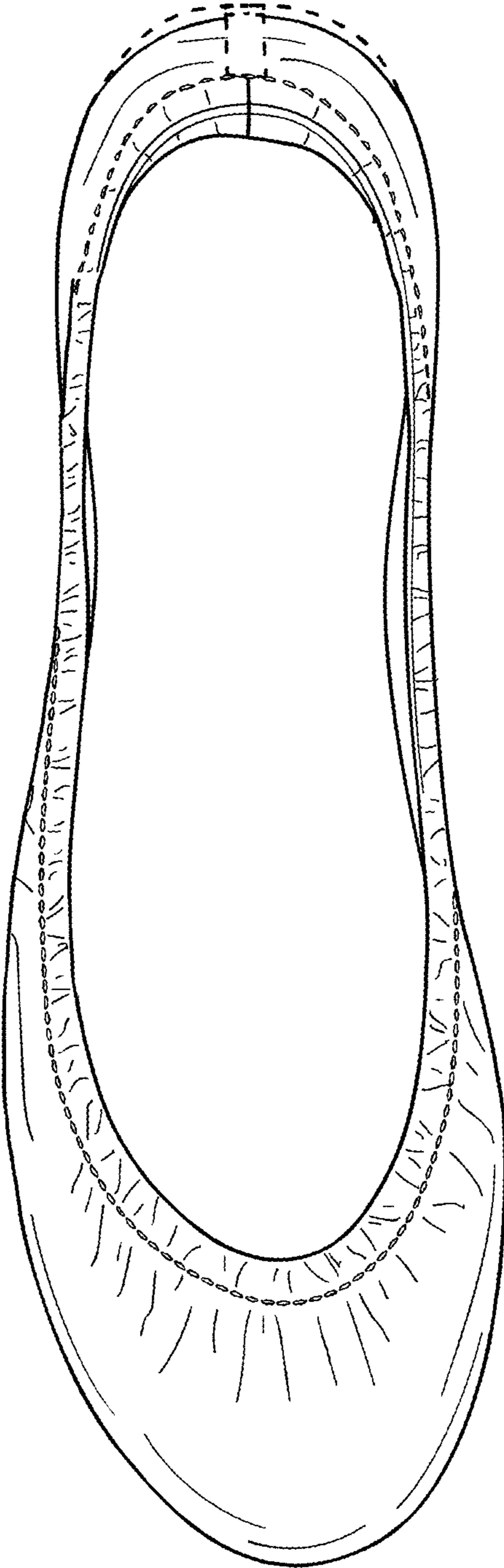

FIG. 67

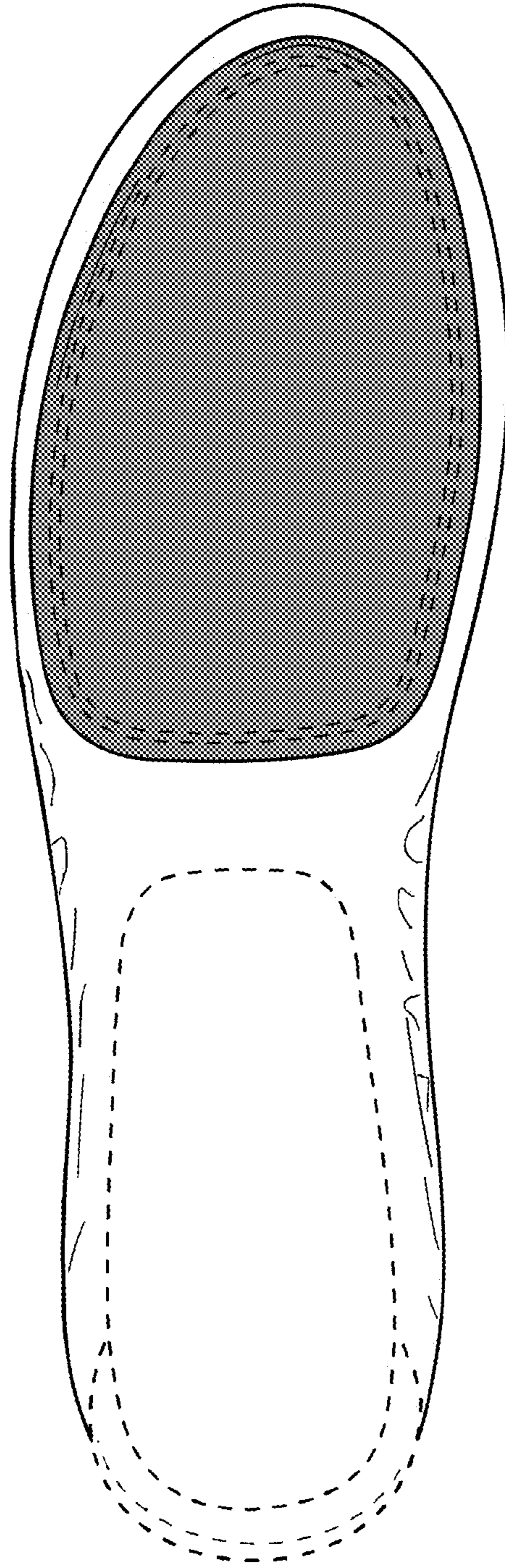

FIG. 68

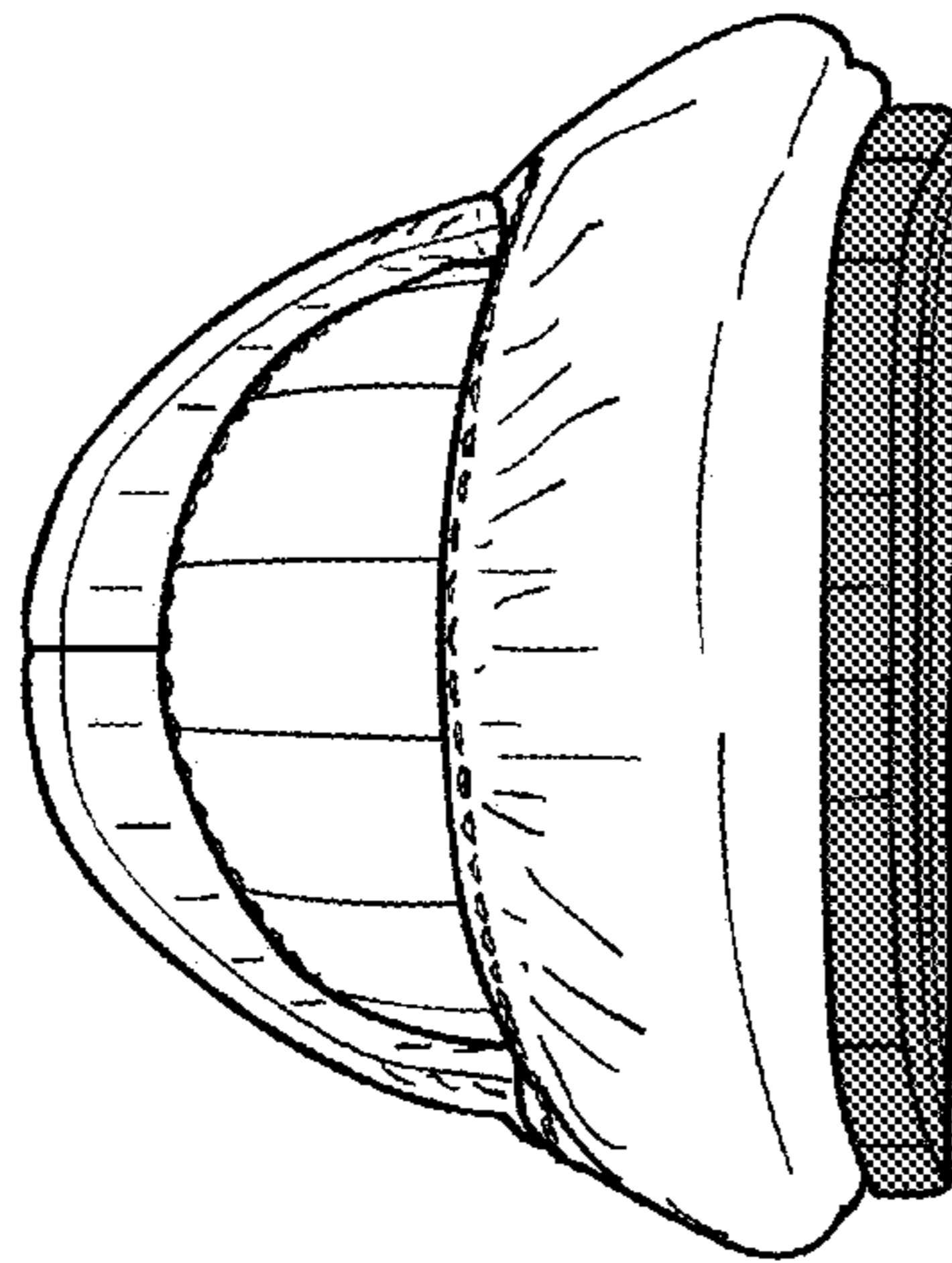

FIG. 69

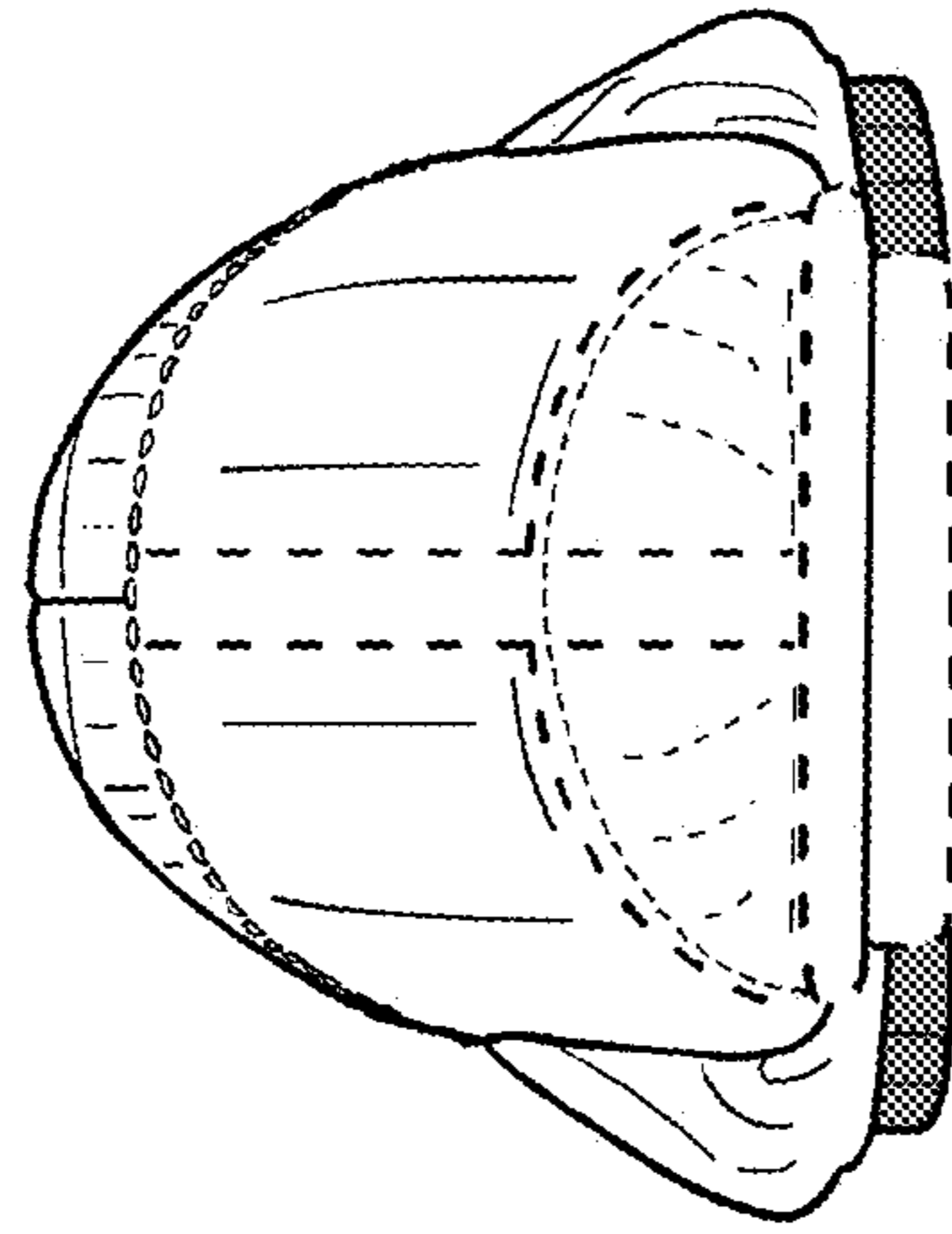

FIG. 70



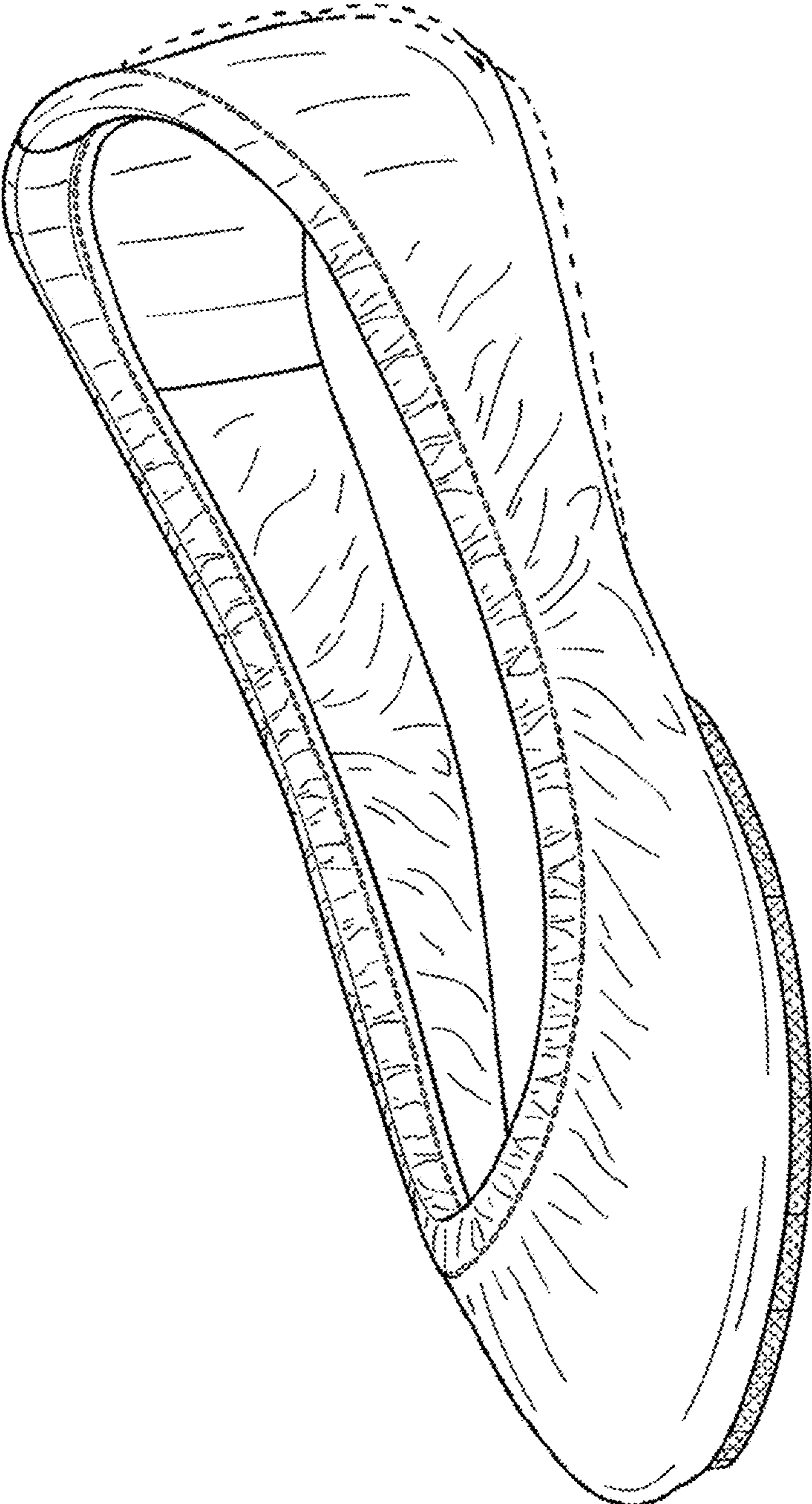

FIG. 71

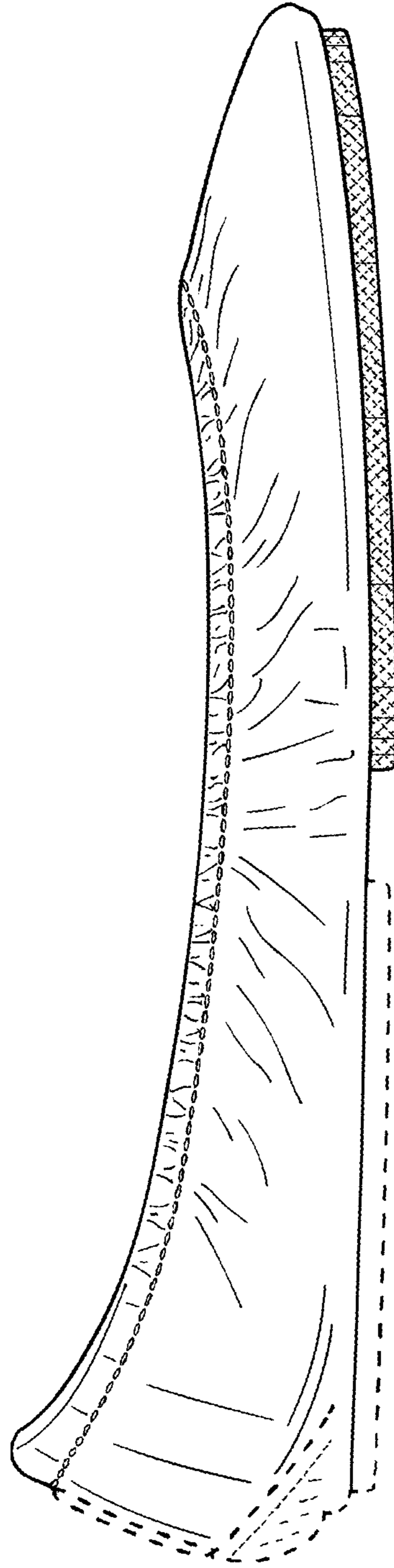

FIG. 72

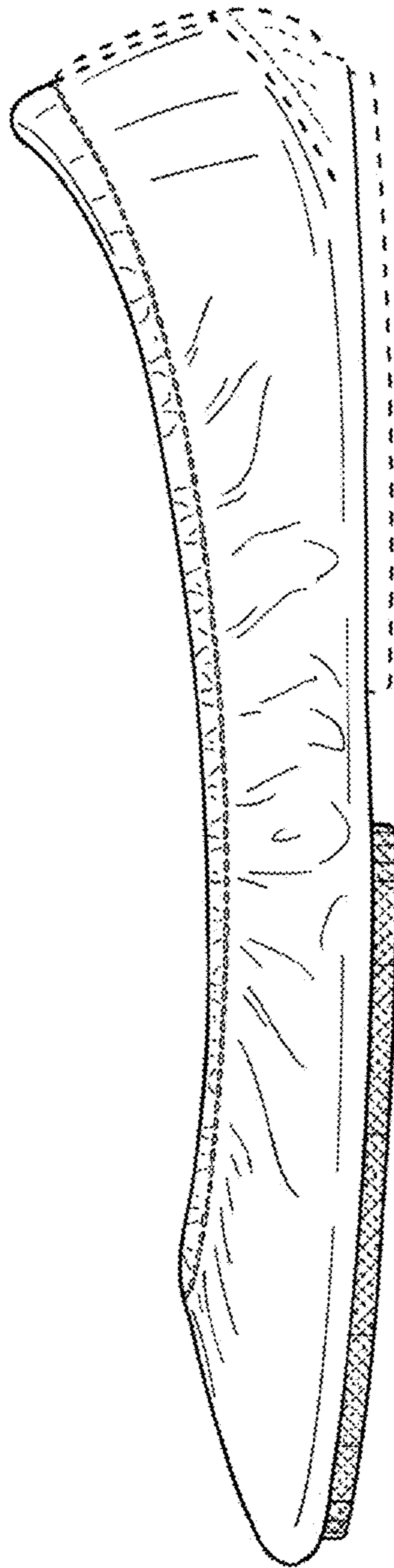

FIG. 73

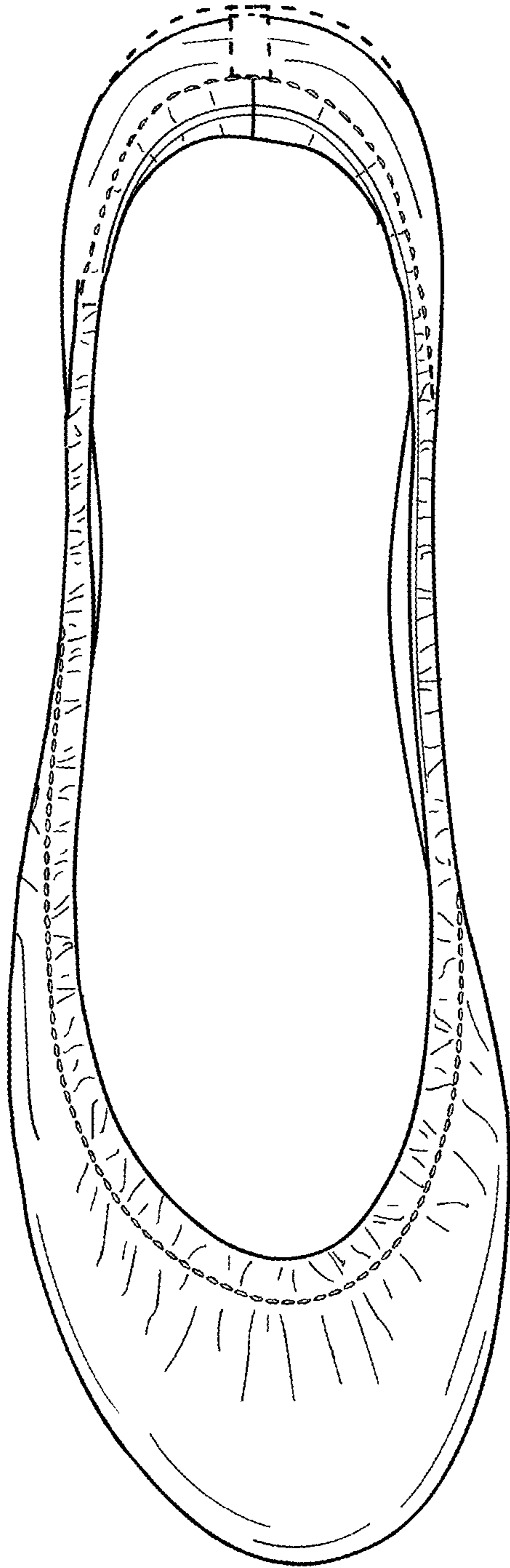

FIG. 74

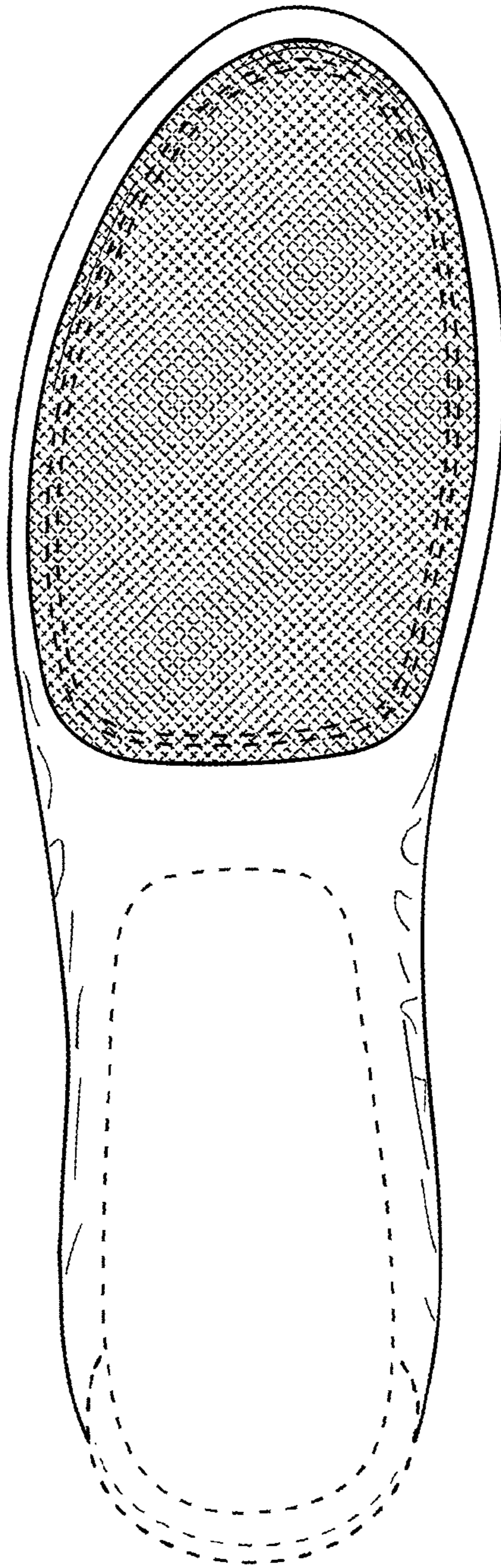

FIG. 75

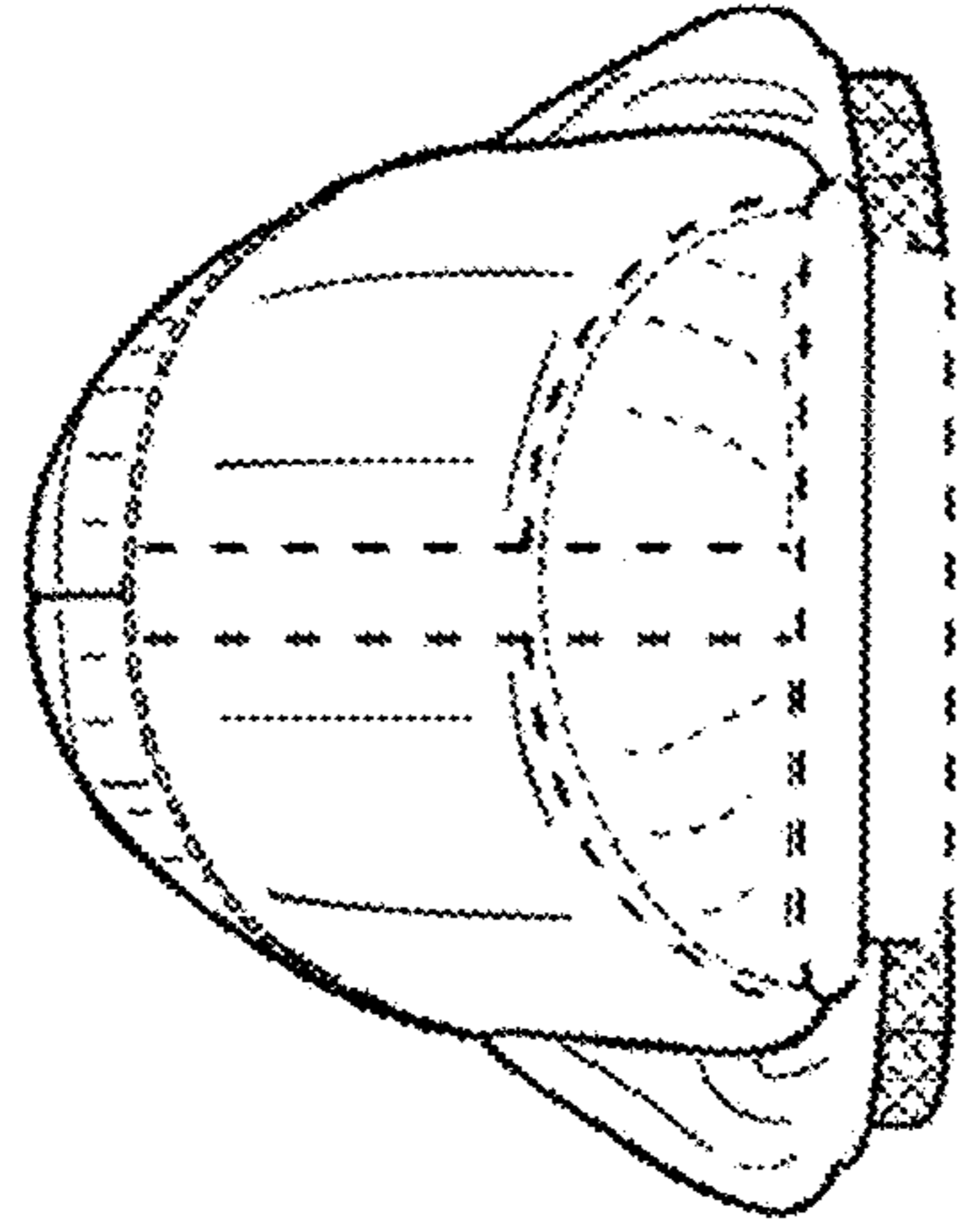

FIG. 76

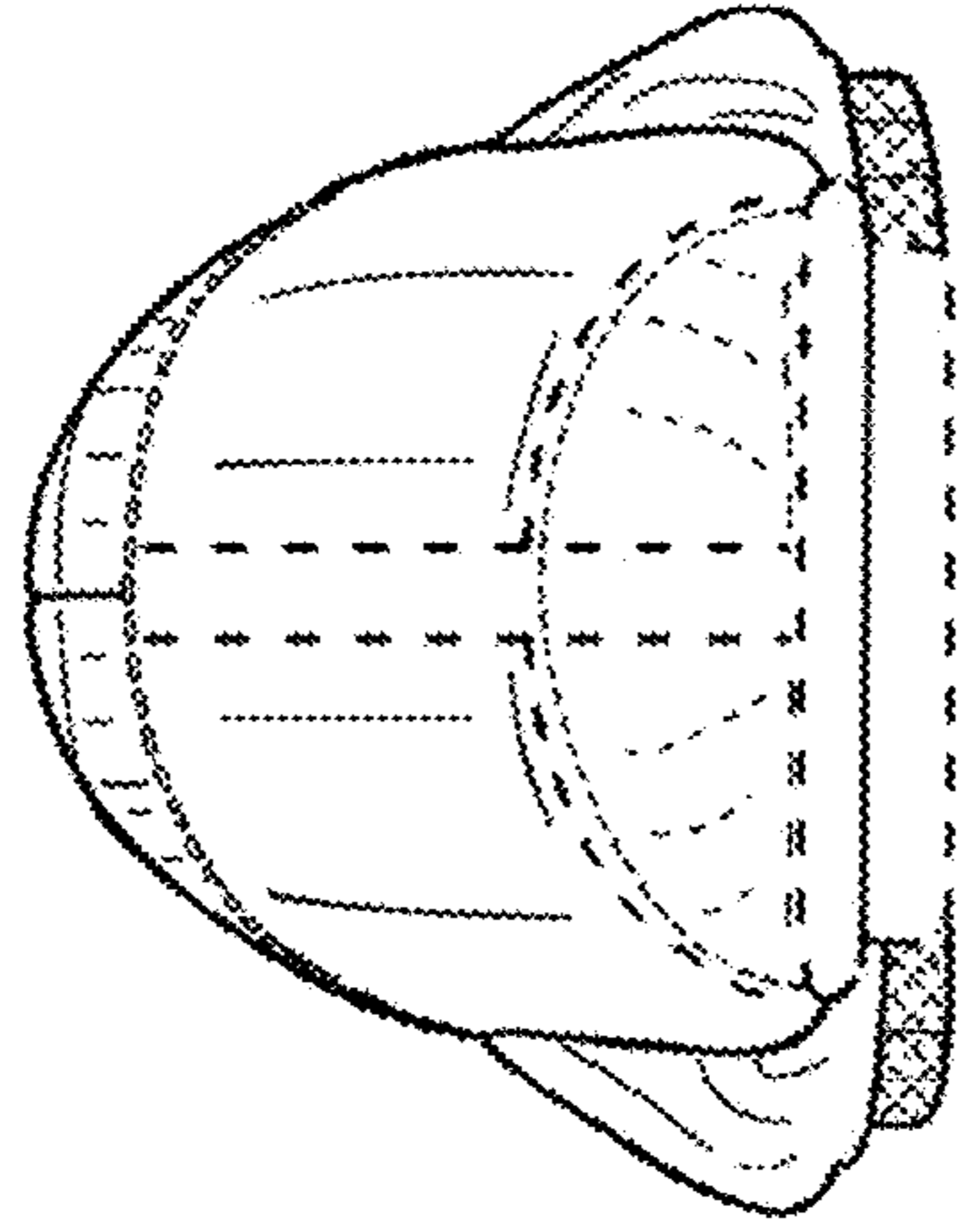

FIG. 77

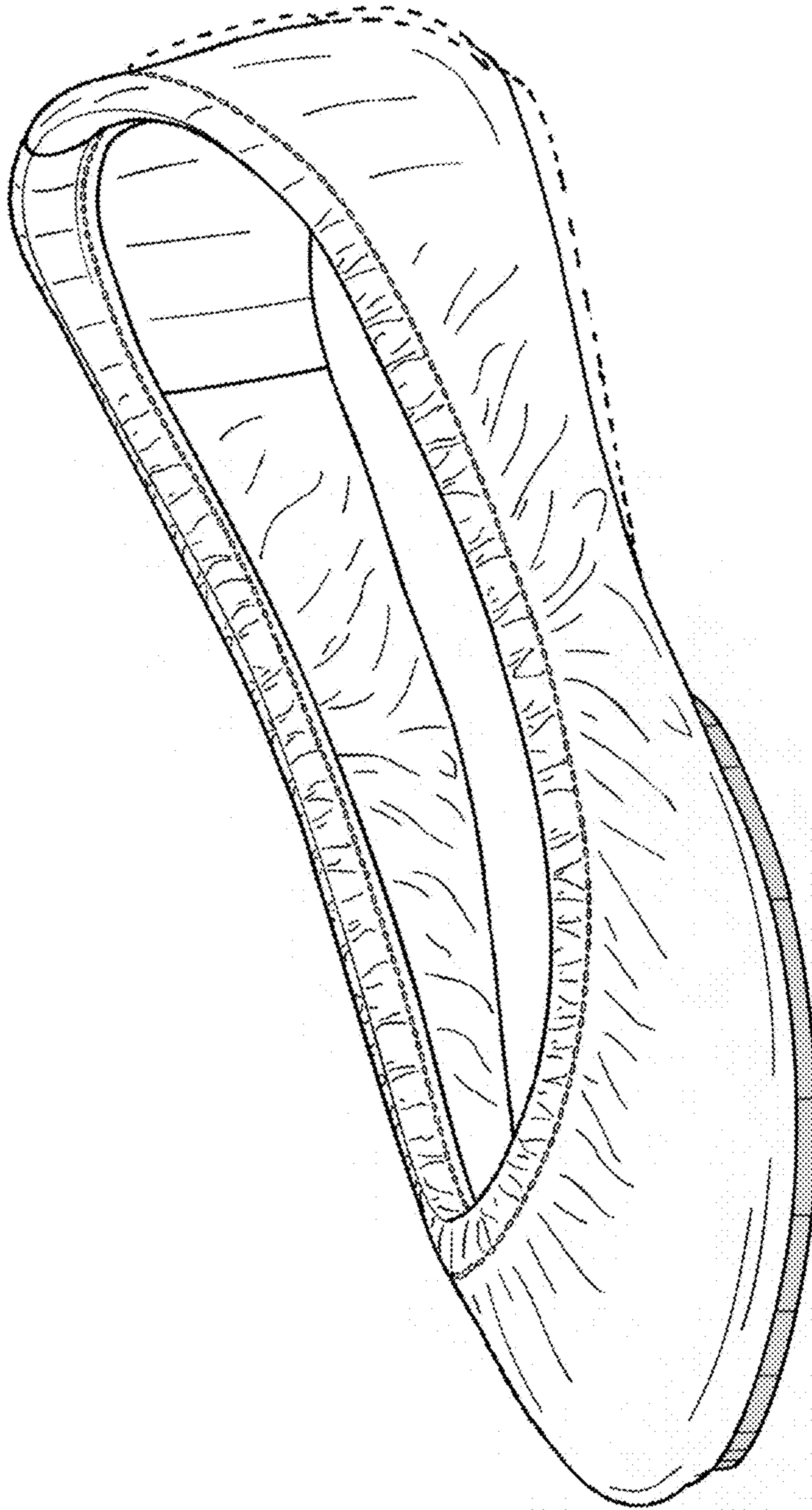

FIG. 78

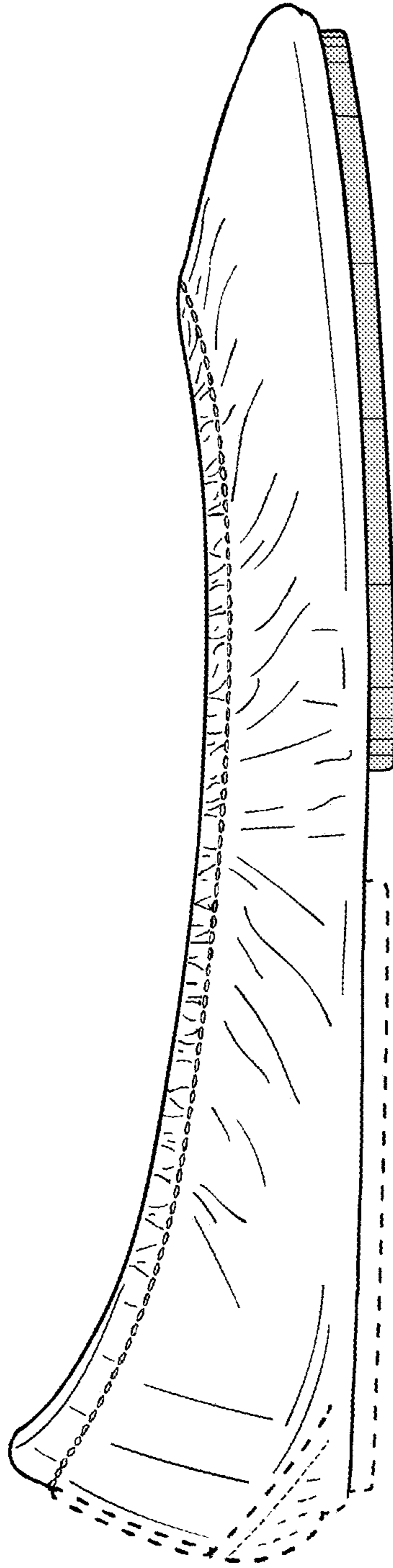

FIG. 79



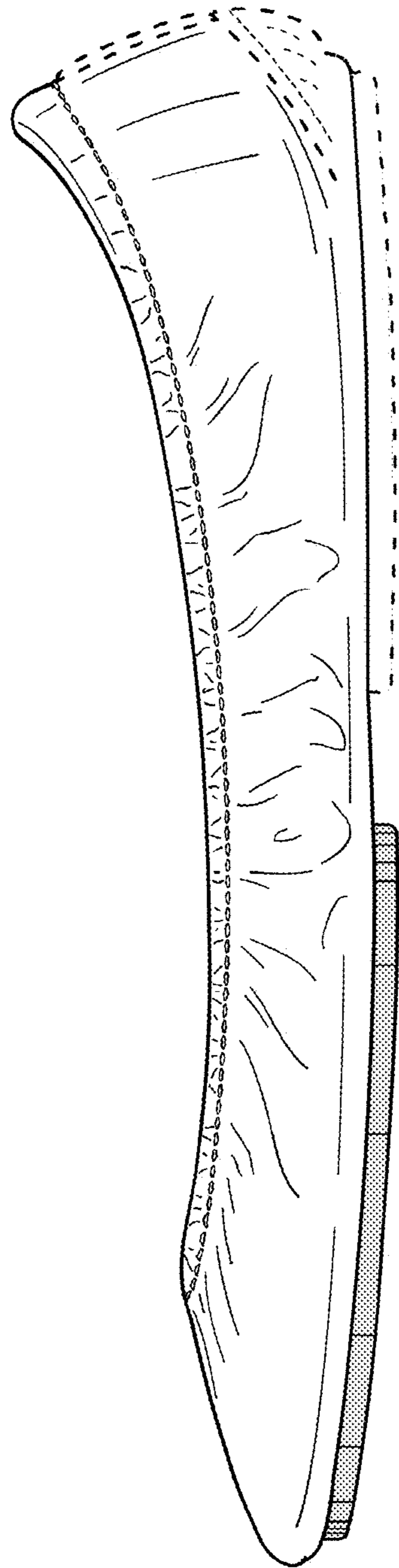

FIG. 80

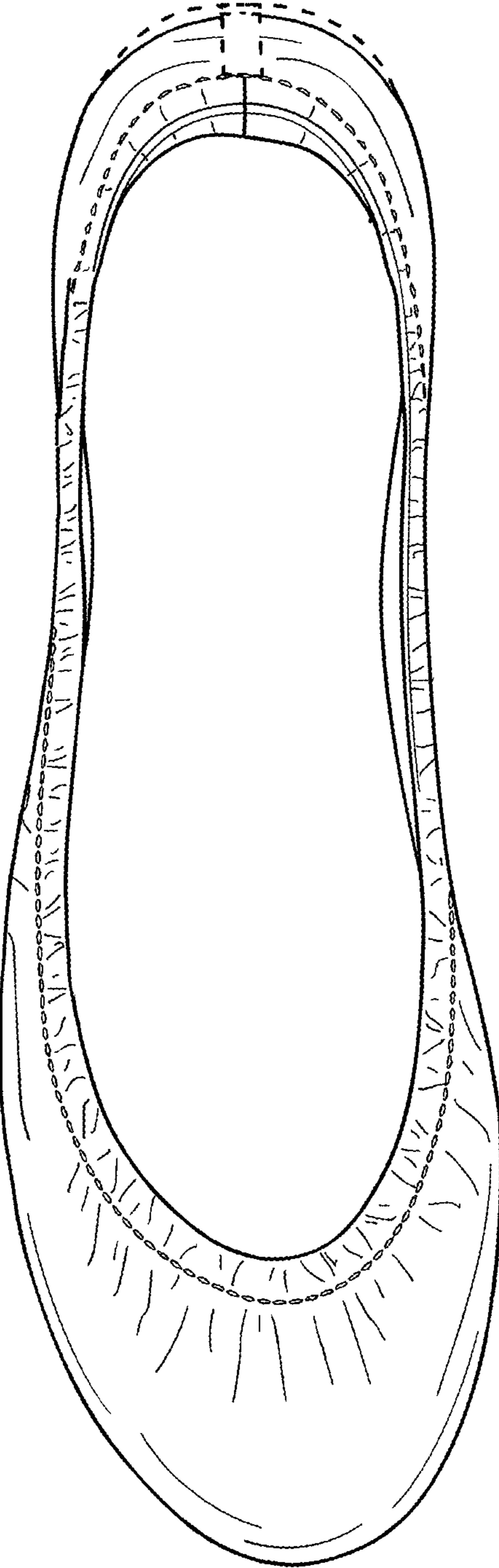

FIG. 81

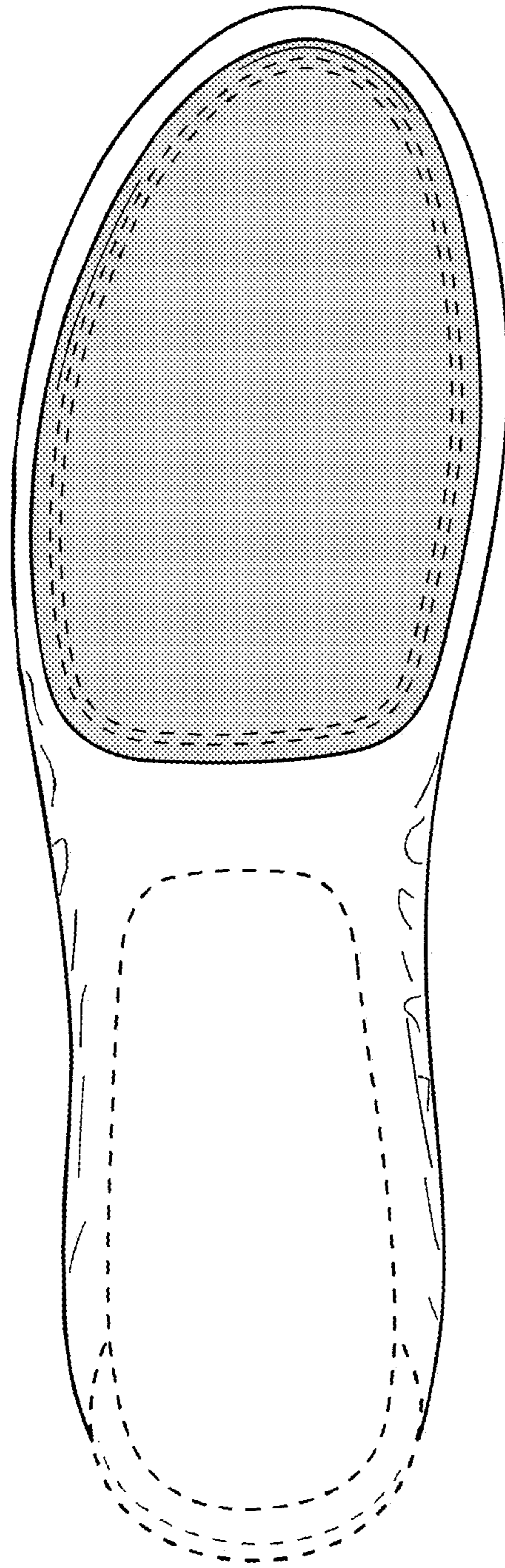

FIG. 82

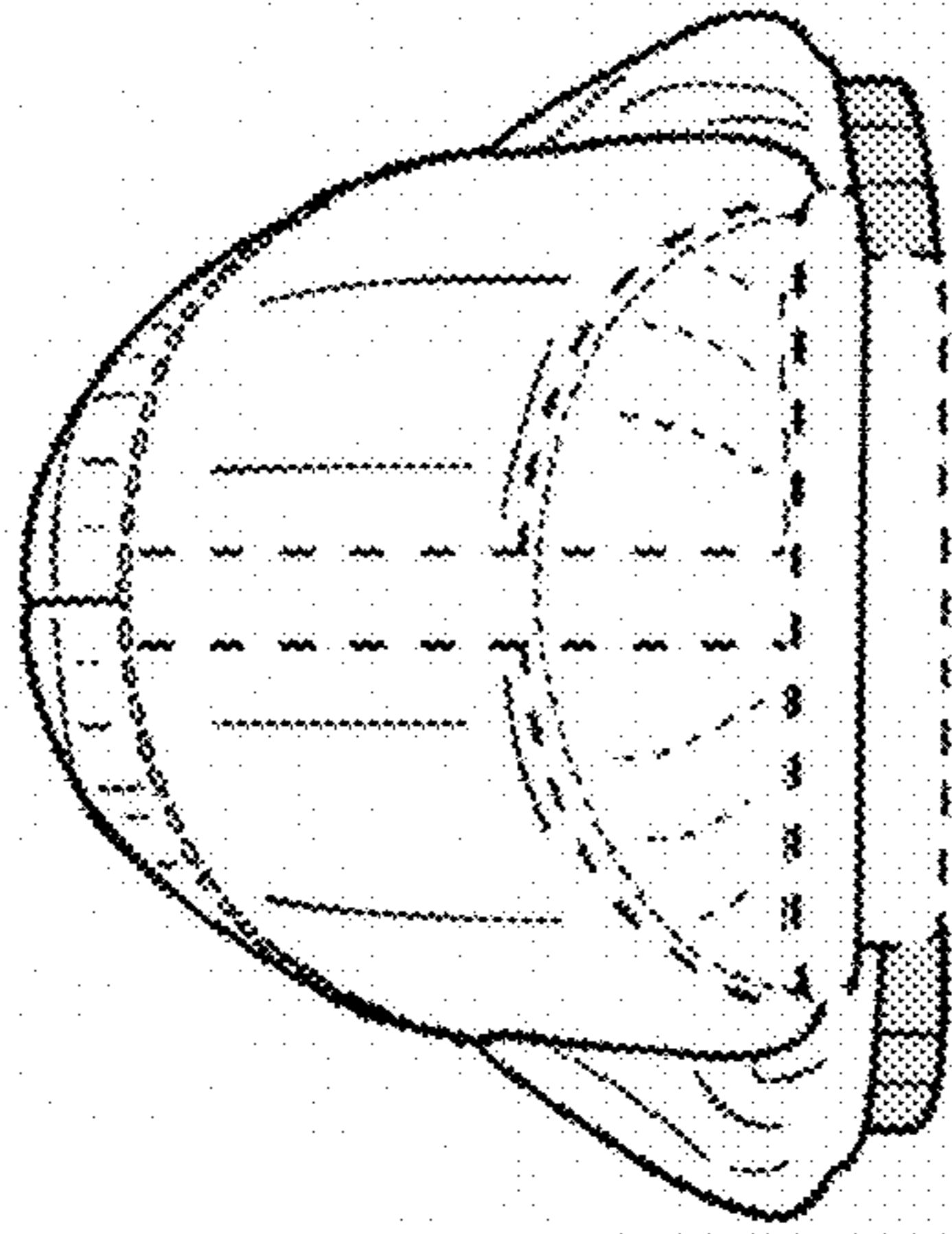

FIG. 84

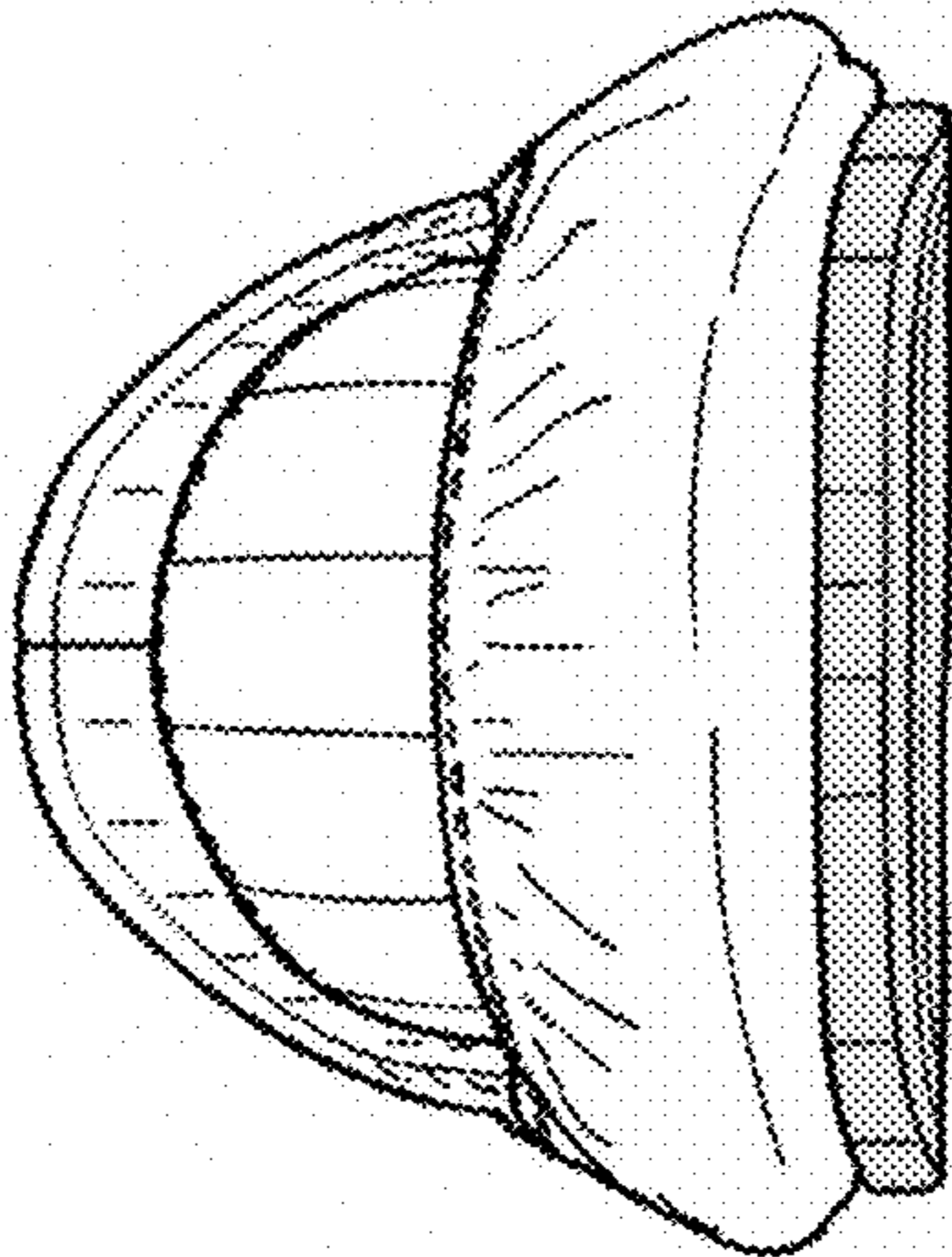

FIG. 83

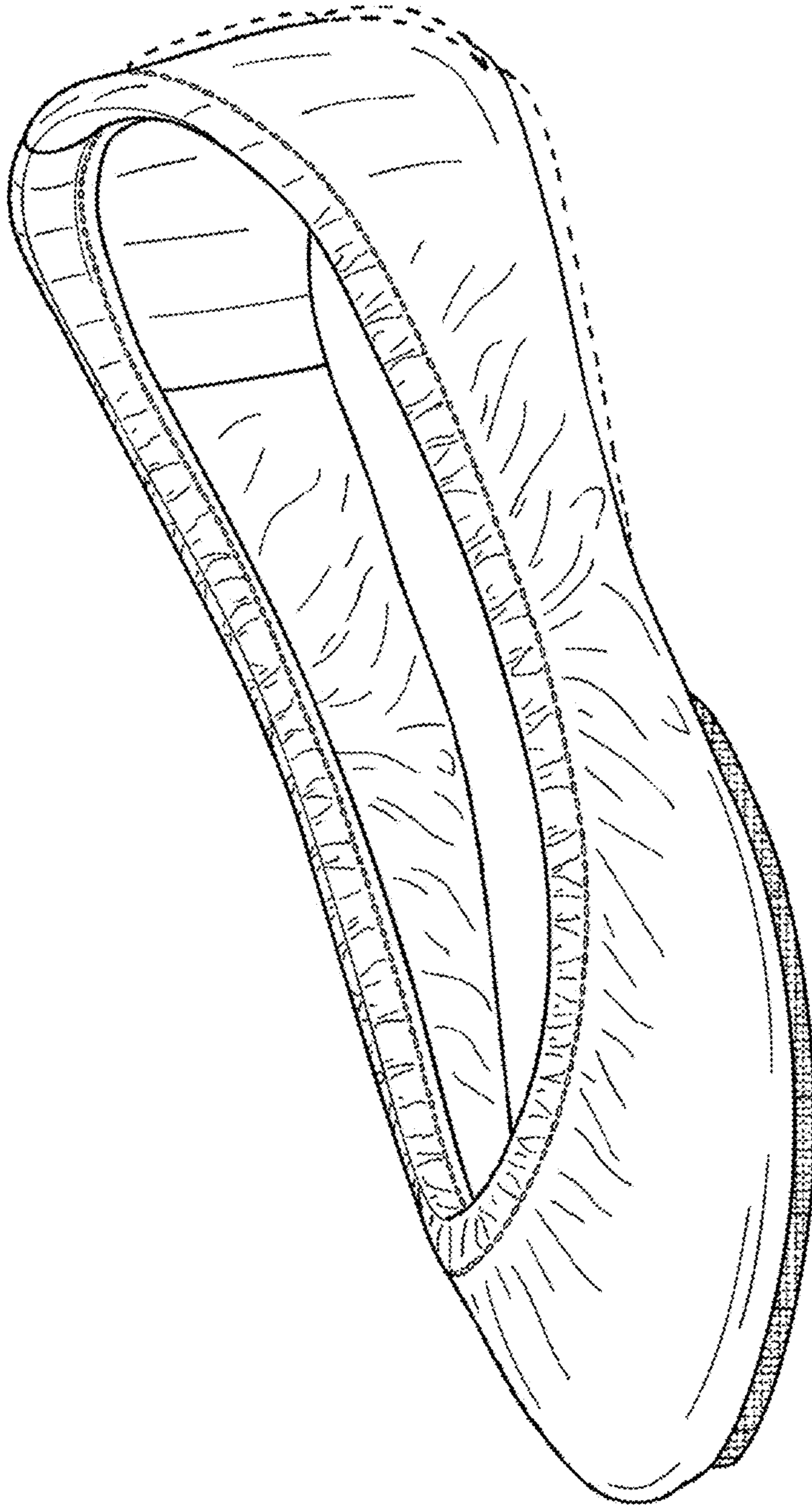

FIG. 85

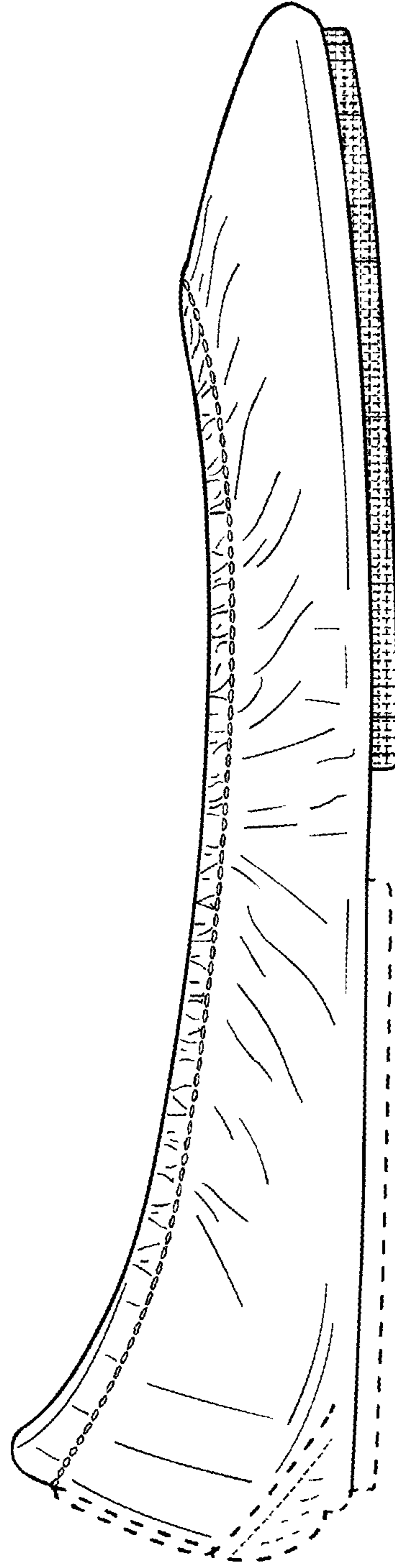

FIG. 86

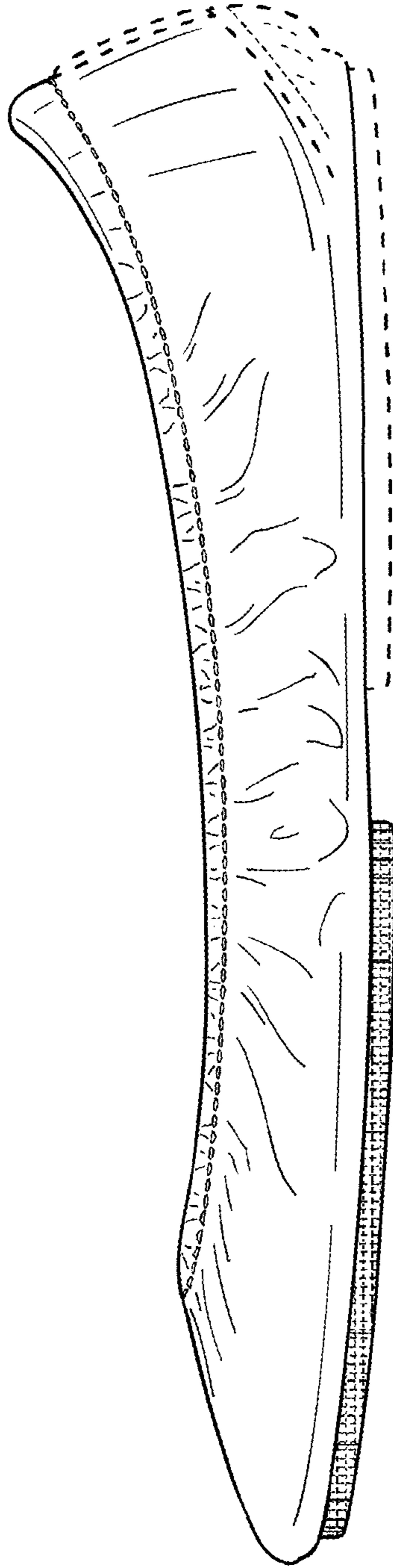

FIG. 87

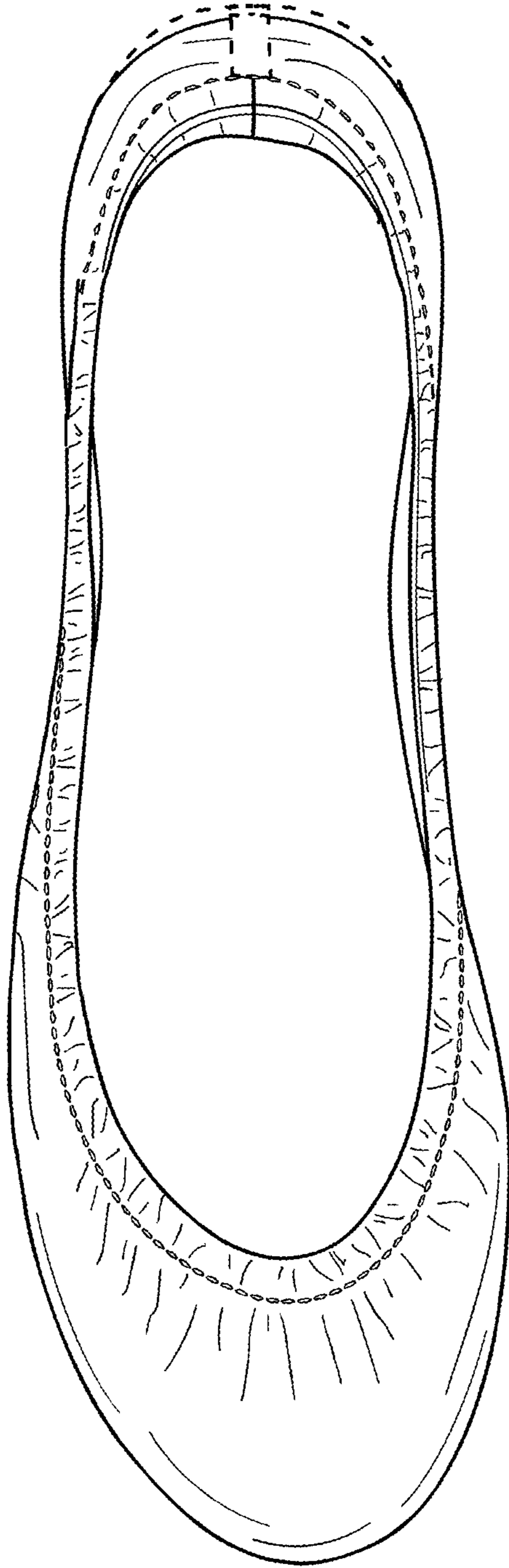

FIG. 88



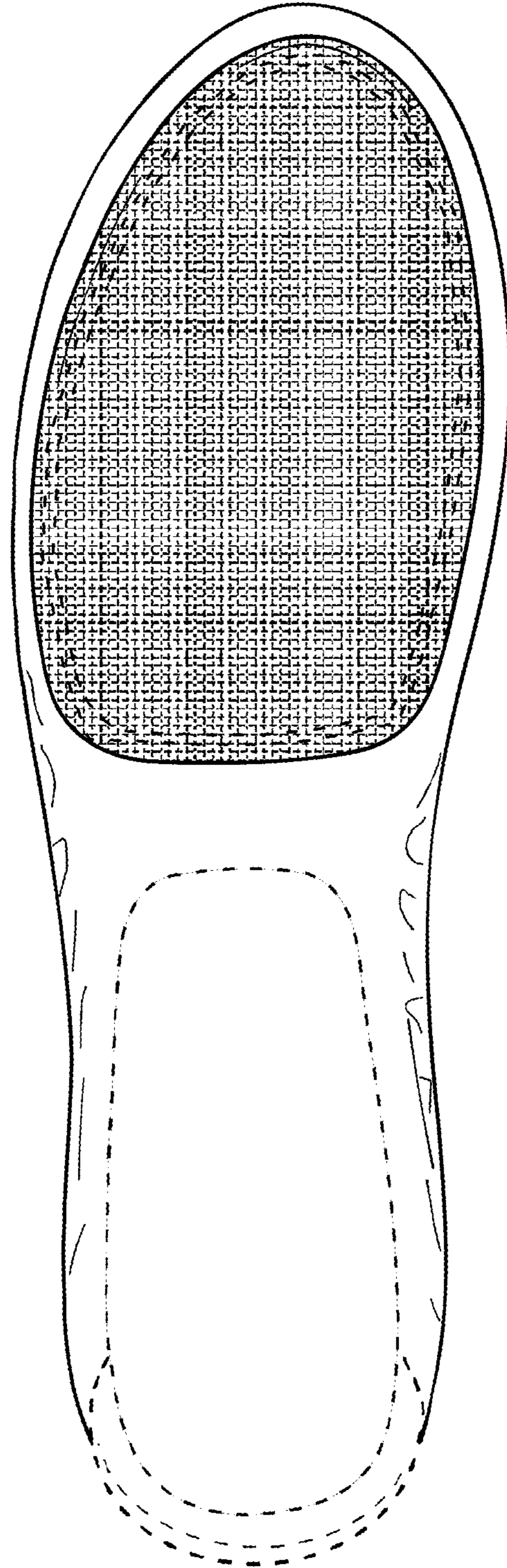

FIG. 89

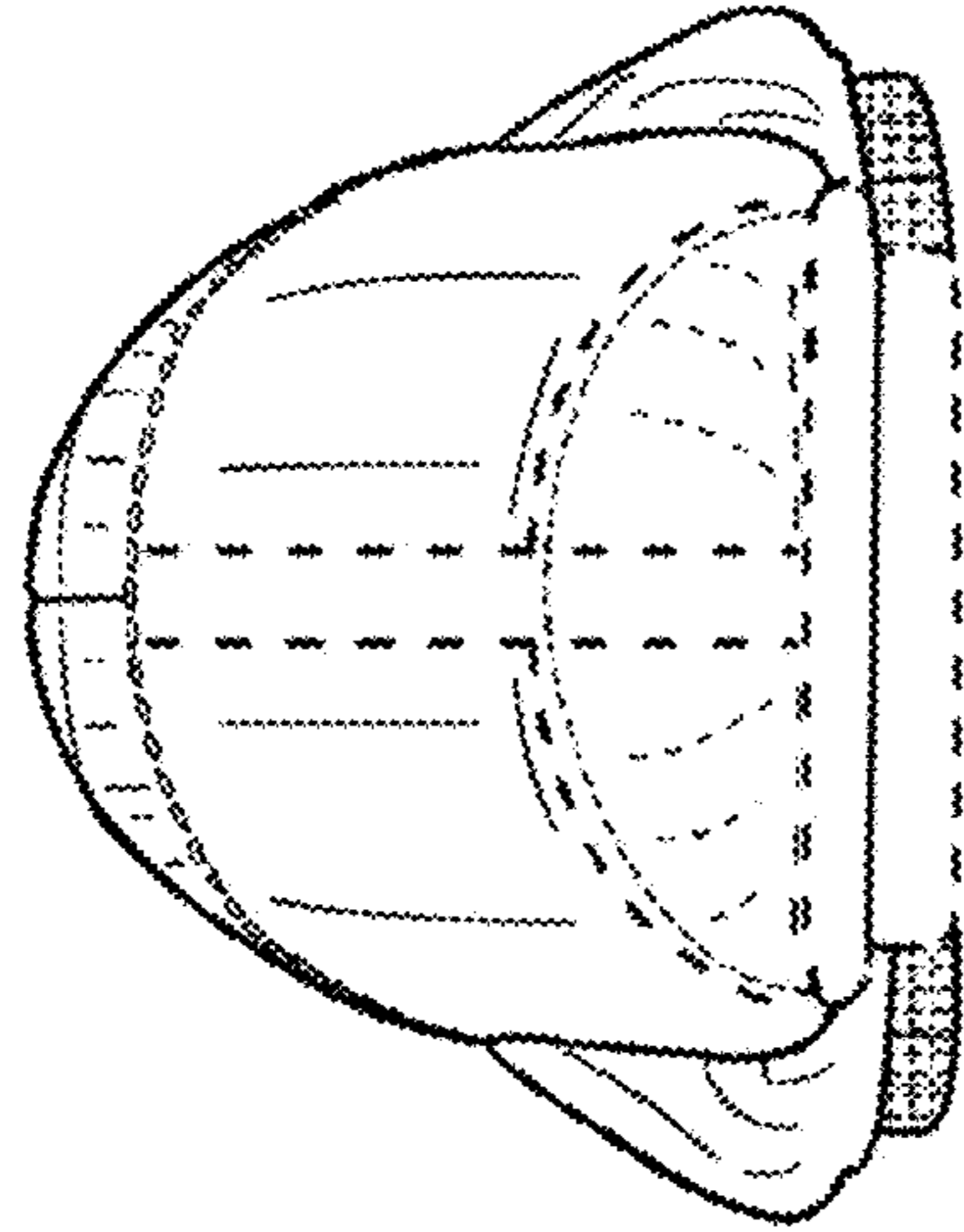

FIG. 91

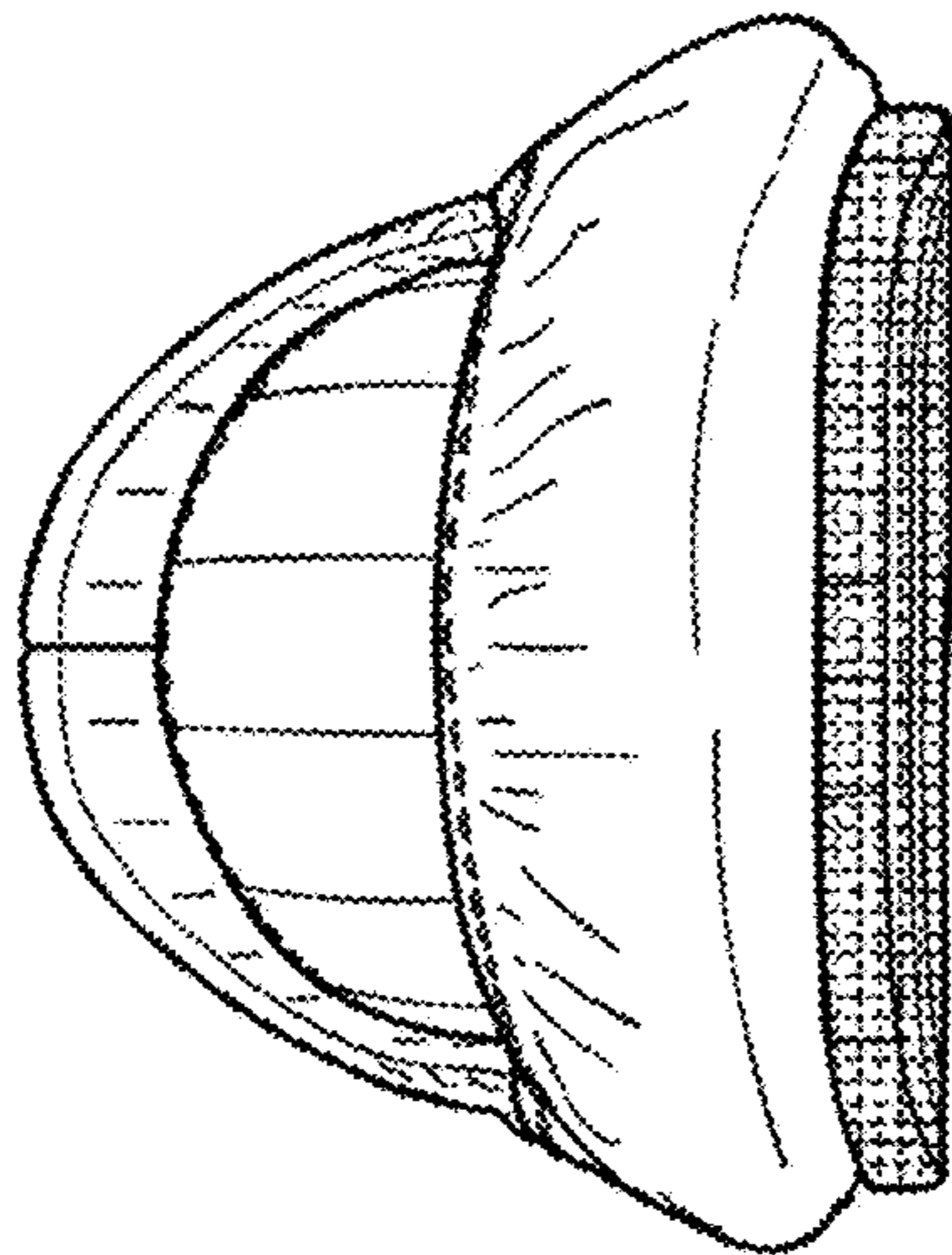

FIG. 90