



US00D846793S

(12) **United States Design Patent** (10) **Patent No.:** **US D846,793 S**  
**Antony et al.** (45) **Date of Patent:** **\*\* Apr. 23, 2019**

(54) **LIGHTING MODULE LOCKING MECHANISM**

(71) Applicant: **Flex Ltd.**, Singapore (SG)  
(72) Inventors: **Ashish Antony**, Anna, TX (US); **Kevin Emr**, Dallas, TX (US); **Jordon Musser**, Dallas, TX (US)

(73) Assignee: **Flex Ltd.**, Singapore (SG)

(\*\*) Term: **15 Years**

(21) Appl. No.: **29/613,370**

(22) Filed: **Aug. 9, 2017**

(51) **LOC (11) Cl.** ..... **26-05**

(52) **U.S. Cl.**  
USPC ..... **D26/140**

(58) **Field of Classification Search**  
USPC ..... D7/213, 402-409; D13/102, 101, 184, D13/199; D26/155, 152, 154, 60, 74, 75, D26/76, 77, 78, 113, 118, 119, 120, 121, D26/122, 128; D8/349, 354, 363, 364, D8/366, 371, 373, 380, 381, 382  
CPC ..... F21Y 2101/00; F21S 2/00; F21S 11/00; F21K 2/00; H01L 31/00; F21V 3/0436  
See application file for complete search history.

(56) **References Cited**

**U.S. PATENT DOCUMENTS**

D120,548 S	5/1940	Guth
D122,145 S	8/1940	MacCarthy
D122,067 S	10/1940	Rubinstein
D122,887 S	10/1940	Beals
D123,887 S	12/1940	Koehler
D127,398 S	5/1941	Jordan
D128,961 S	8/1941	Hrabak
D129,726 S	9/1941	Scribner
D130,570 S	12/1941	Borkland
2,312,617 A	3/1943	Beck

(Continued)

**OTHER PUBLICATIONS**

Flex Essentials Series Sell Specification Sheets, Published Jun. 2016 (28 pages).

(Continued)

*Primary Examiner* — Mark A Goodwin

*Assistant Examiner* — Benjamin M Weeks

(74) *Attorney, Agent, or Firm* — Carter, DeLuca, Farrell & Schmidt, LLP

(57) **CLAIM**

What is claimed the ornamental design for a lighting module locking mechanism, as shown and described.

**DESCRIPTION**

FIG. 1 is a front, perspective view of a lighting module locking mechanism in accordance with the present design; FIG. 2 is a front view of the lighting module locking mechanism of FIG. 1; FIG. 3 is a rear view of the lighting module locking mechanism of FIG. 1; FIG. 4 is a left, side view of the lighting module locking mechanism of FIG. 1; FIG. 5 is a right, side view of the lighting module locking mechanism of FIG. 1; FIG. 6 is a top view of the lighting module locking mechanism of FIG. 1; FIG. 7 is a bottom view of the lighting module locking mechanism of FIG. 1; and, FIG. 8 is a perspective view of the lighting module locking mechanism of FIG. 1, with components of a lighting module shown attached to the lighting module locking mechanism of FIG. 1 and in broken lines to illustrate environment for the lighting module locking mechanism of FIG. 1. The broken lines provided in the drawings form no part of the claimed design.

**1 Claim, 5 Drawing Sheets**

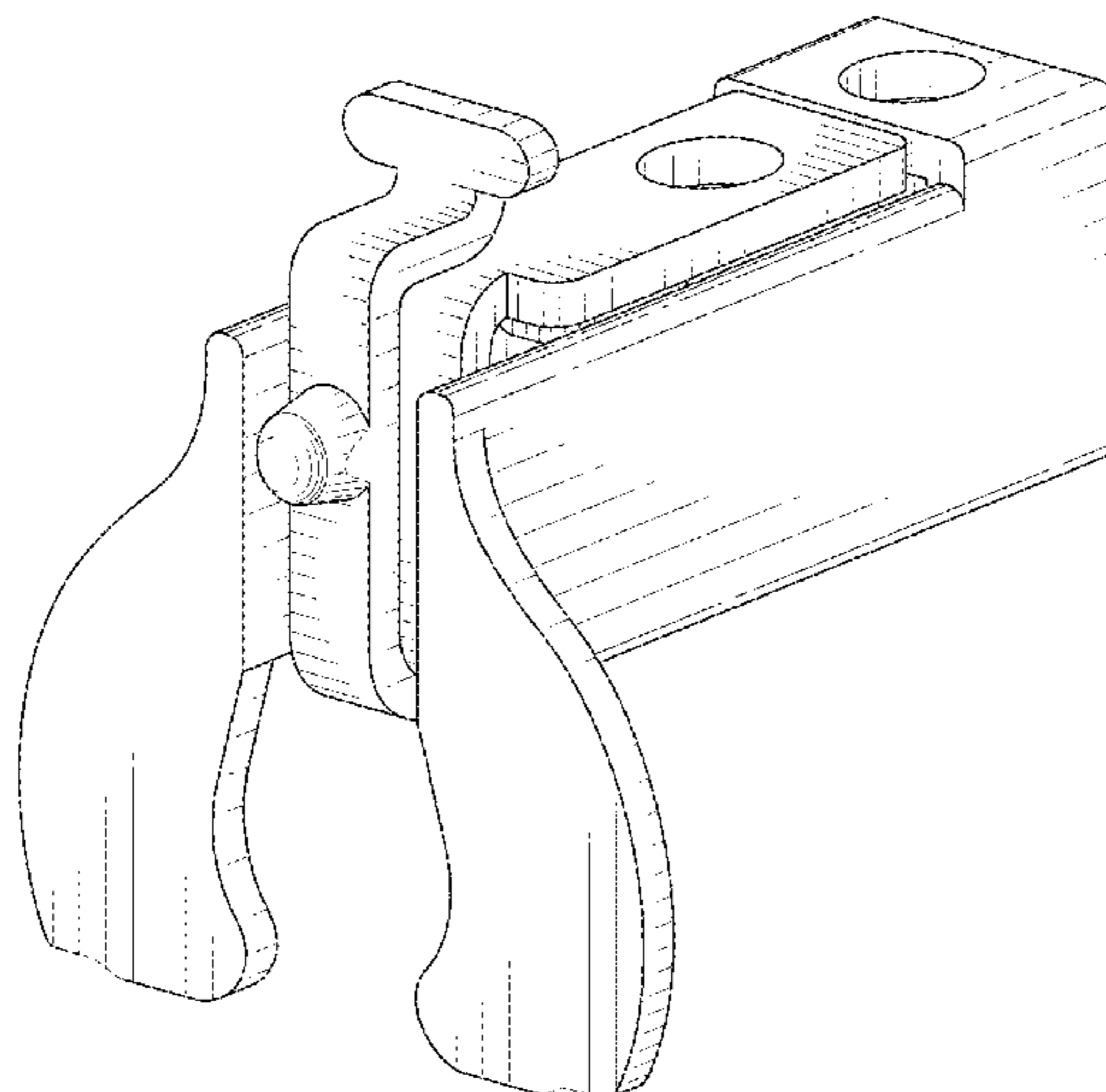

(56)

References Cited

U.S. PATENT DOCUMENTS

D139,669 S	12/1944	Lippincott	7,663,342 B2	2/2010	Kimball et al.
D142,126 S	8/1945	Sabatini	7,670,638 B2	3/2010	Luan et al.
D150,735 S	8/1948	Schwartz et al.	7,681,090 B2	3/2010	Kimball et al.
D151,575 S	10/1948	Winkler et al.	7,705,237 B2	4/2010	Swanson
2,606,998 A	8/1952	Winkler et al.	7,708,578 B1	5/2010	Lenox
D173,255 S	10/1954	Brooks et al.	7,718,888 B2	5/2010	Cousins
2,715,449 A	8/1955	Lemmerman et al.	7,737,357 B2	6/2010	Cousins
2,849,595 A *	8/1958	Zurawski ..... F21V 21/02 362/219	7,755,916 B2	7/2010	Krein et al.
			7,774,998 B2	8/2010	Aschenbrenner
D188,436 S	7/1960	Budke et al.	7,780,472 B2	8/2010	Lenox
3,009,055 A	11/1961	Franzese	7,786,375 B2	8/2010	Swanson et al.
3,209,142 A	9/1965	Michel et al.	7,804,022 B2	9/2010	De Ceuster
D208,491 S	9/1967	Brooks	7,807,918 B2	10/2010	Shingleton et al.
D255,851 S	7/1980	Crane	7,812,250 B2	10/2010	Smith
D291,598 S	8/1987	Elkerbout	7,820,475 B2	10/2010	De Ceuster et al.
4,726,781 A	2/1988	Bernhart et al.	7,824,070 B2	11/2010	Higley et al.
D391,136 S *	2/1998	King, Jr. .... D8/354	7,838,062 B2	11/2010	Cousins et al.
6,061,978 A	5/2000	Dinwoodie et al.	7,851,698 B2	12/2010	De Ceuster et al.
6,076,943 A	6/2000	Lassovsky	D632,418 S	2/2011	Bisberg et al.
6,274,402 B1	8/2001	Verlinden et al.	7,883,343 B1	2/2011	Mulligan et al.
6,295,818 B1	10/2001	Ansley et al.	7,888,587 B2	2/2011	Shingleton et al.
6,313,395 B1	11/2001	Crane et al.	7,888,588 B2	2/2011	Shingleton
6,333,457 B1	12/2001	Mulligan et al.	7,893,409 B1	2/2011	Cousins
6,337,283 B1	1/2002	Verlinden et al.	7,897,867 B1	3/2011	Mulligan et al.
6,387,726 B1	5/2002	Verlinden et al.	7,945,413 B2	5/2011	Krein
6,423,568 B1	7/2002	Verlinden et al.	7,956,281 B2	6/2011	O'Brien et al.
6,495,750 B1	12/2002	Dinwoodie	7,958,886 B2	6/2011	Barsun et al.
6,501,013 B1	12/2002	Dinwoodie	7,982,434 B2	7/2011	Kimball et al.
D472,007 S	3/2003	Weitgasser	7,994,657 B2	8/2011	Kimball et al.
6,536,326 B2	3/2003	Unger et al.	8,004,865 B2	8/2011	Krein et al.
6,570,084 B2	5/2003	Dinwoodie	8,008,575 B2	8/2011	De Ceuster et al.
6,684,637 B2	2/2004	Beale	D644,609 S	9/2011	Marroquin
6,722,357 B2	4/2004	Shingleton	D644,610 S	9/2011	Marroquin
6,745,687 B1	6/2004	Kaminar	8,029,683 B2	10/2011	Rose et al.
D492,809 S	7/2004	Weitgasser	8,061,091 B2	11/2011	Botkin et al.
6,809,251 B2	10/2004	Dinwoodie	8,062,693 B2	11/2011	Cousins
6,809,253 B2	10/2004	Dinwoodie	8,065,844 B2	11/2011	Botkin et al.
6,883,290 B2	4/2005	Dinwoodie	8,080,819 B2	12/2011	Mueller et al.
D510,315 S	10/2005	Shugar et al.	D651,970 S *	1/2012	Turk ..... D13/102
D511,576 S	11/2005	Shingleton et al.	8,101,849 B2	1/2012	Almy et al.
D516,017 S	2/2006	Mascolo	8,108,081 B2	1/2012	Lenox
6,998,288 B1	2/2006	Smith et al.	8,120,933 B2	2/2012	Chapman et al.
D519,444 S	4/2006	Mascolo	8,134,217 B2	3/2012	Rim et al.
D521,172 S	5/2006	Chen	8,148,627 B2	4/2012	Rose et al.
7,072,096 B2	7/2006	Holman et al.	8,158,877 B2	4/2012	Klein et al.
7,135,350 B1	11/2006	Smith et al.	8,163,638 B2	4/2012	De Ceuster et al.
7,140,742 B2	11/2006	Pohlert et al.	8,172,989 B2	5/2012	Pass
7,144,214 B2	12/2006	Kinpara et al.	8,174,856 B2	5/2012	Chapman
7,155,870 B2	1/2007	Almy	8,188,363 B2	5/2012	Xavier et al.
7,172,184 B2	2/2007	Pavani et al.	8,192,048 B2	6/2012	Kristoffersen et al.
7,178,295 B2	2/2007	Dinwoodie	8,192,056 B2	6/2012	Villard
7,178,941 B2	2/2007	Roberge et al.	8,193,788 B2	6/2012	Chapman
7,297,865 B2	11/2007	Terao et al.	8,198,528 B2	6/2012	Luan et al.
7,297,866 B2	11/2007	Aschenbrenner	8,206,009 B2	6/2012	Tickner et al.
D562,225 S	2/2008	Almy et al.	8,207,444 B2	6/2012	Cousins
7,328,534 B2	2/2008	Dinwoodie	8,207,637 B2	6/2012	Marroquin et al.
RE40,158 E	3/2008	Weitgasser	8,211,731 B2	7/2012	Harley et al.
D564,958 S	3/2008	Almy et al.	8,215,071 B2	7/2012	Lenox
7,339,110 B1	3/2008	Mulligan et al.	8,220,210 B2	7/2012	Botkin et al.
D565,505 S	4/2008	Shugar et al.	8,221,600 B2	7/2012	Ganti
7,388,147 B2	6/2008	Mulligan et al.	8,221,601 B2	7/2012	Chen et al.
7,390,961 B2	6/2008	Aschenbrenner et al.	8,222,516 B2	7/2012	Cousins
7,435,134 B2	10/2008	Lenox	8,227,942 B2	7/2012	Marroquin et al.
7,438,432 B2	10/2008	Yaphe et al.	8,230,850 B2	7/2012	Barsun et al.
7,455,787 B2	11/2008	Rose et al.	8,234,824 B2	8/2012	Botkin et al.
7,468,485 B1	12/2008	Swanson	8,242,354 B2	8/2012	Smith
D586,737 S	2/2009	Shugar et al.	D666,974 S	9/2012	Marroquin et al.
D592,785 S	5/2009	Bisberg et al.	8,258,395 B2	9/2012	Wares
7,530,830 B1	5/2009	Lenox	8,263,899 B2	9/2012	Harley et al.
7,554,030 B2	6/2009	Shingleton	8,276,329 B2	10/2012	Lenox
7,554,031 B2	6/2009	Swanson et al.	8,279,642 B2	10/2012	Chapman et al.
7,557,292 B2	7/2009	Shingleton et al.	8,279,649 B2	10/2012	Esrasm et al.
7,622,912 B1	11/2009	Adams et al.	8,284,574 B2	10/2012	Chapman et al.
7,633,006 B1	12/2009	Swanson	8,291,654 B2	10/2012	Botkin et al.
7,648,257 B2	1/2010	Villard	8,294,022 B2	10/2012	Lenox
			8,304,644 B2	11/2012	Wares et al.
			8,308,324 B2	11/2012	Van Horn et al.
			8,317,987 B2	11/2012	Abas et al.
			D673,320 S	12/2012	Guercio et al.



(56)

References Cited

U.S. PATENT DOCUMENTS

8,322,300 B2	12/2012	Pavani et al.	8,662,008 B2	3/2014	Abas et al.
8,324,015 B2	12/2012	Harley et al.	8,664,519 B2	3/2014	De Ceuster et al.
8,325,499 B2	12/2012	Krein et al.	8,679,889 B2	3/2014	Cousins et al.
8,334,161 B2	12/2012	Dennis et al.	D703,858 S	4/2014	Miller
8,334,489 B2	12/2012	Beardsworth et al.	8,683,761 B2	4/2014	Danning
8,336,539 B2	12/2012	Linderman et al.	8,692,111 B2	4/2014	Kim et al.
8,350,411 B2	1/2013	Kimball et al.	8,709,851 B2	4/2014	Dennis et al.
8,350,417 B1	1/2013	Dooley et al.	8,712,745 B2	4/2014	Wayne et al.
8,352,220 B2	1/2013	Wayne et al.	8,716,596 B1	5/2014	Swanson
8,360,601 B2	1/2013	Muschaweck et al.	8,737,093 B1	5/2014	Baker et al.
8,377,738 B2	2/2013	Dennis et al.	8,737,100 B2	5/2014	Chapman et al.
8,378,706 B2	2/2013	Kinyon et al.	8,744,791 B1	6/2014	Kraft et al.
8,393,707 B2	3/2013	Cudzinovic et al.	8,748,736 B2	6/2014	Luan et al.
8,399,287 B1	3/2013	Mulligan et al.	8,754,627 B1	6/2014	Le
8,402,703 B2	3/2013	Brandt et al.	8,757,567 B2	6/2014	Ciasulli et al.
8,409,902 B1	4/2013	Harley et al.	8,763,316 B2	7/2014	Concho et al.
8,409,911 B2	4/2013	Cousins	8,767,421 B2	7/2014	Chapman
8,409,912 B2	4/2013	de Ceuster et al.	8,772,894 B2	7/2014	Smith
8,423,312 B2	4/2013	Krein	8,774,007 B2	7/2014	Hussain et al.
8,424,255 B2	4/2013	Lenox et al.	8,776,781 B2	7/2014	Meydbray
8,426,974 B2	4/2013	Linderman et al.	8,778,787 B2	7/2014	Manning
8,448,391 B2	5/2013	Botkin et al.	8,785,233 B2	7/2014	Loscutoff et al.
8,448,652 B2	5/2013	Almy et al.	8,785,236 B2	7/2014	Harley et al.
8,449,238 B2	5/2013	Mulligan et al.	8,785,830 B2	7/2014	Judkins
8,450,134 B2	5/2013	De Ceuster et al.	8,786,095 B2	7/2014	Linderman et al.
8,450,985 B2	5/2013	Gray et al.	8,790,957 B2	7/2014	Li et al.
8,451,638 B2	5/2013	Chapman et al.	8,793,942 B2	8/2014	Almy et al.
8,455,806 B2	6/2013	Judkins	8,796,061 B2	8/2014	Bunea
8,456,876 B2	6/2013	Chapman	8,796,535 B2	8/2014	Linderman
8,460,963 B2	6/2013	Smith	8,796,884 B2	8/2014	Naiknaware et al.
8,461,813 B2	6/2013	Chapman	8,802,486 B2	8/2014	Li et al.
8,462,518 B2	6/2013	Marroquin et al.	8,809,671 B2	8/2014	Linderman et al.
8,482,947 B2	7/2013	Chapman et al.	8,815,631 B2	8/2014	Cousins
8,486,746 B2	7/2013	Rim et al.	8,817,510 B2	8/2014	Esrasm et al.
8,492,253 B2	7/2013	Manning	8,818,924 B2	8/2014	Wayne et al.
8,503,200 B2	8/2013	Chapman et al.	8,822,257 B2	9/2014	Rim et al.
8,508,964 B2	8/2013	Gray et al.	8,822,262 B2	9/2014	Loscutoff et al.
8,516,754 B2	8/2013	Botkin et al.	8,822,812 B2	9/2014	Wares
8,519,729 B2	8/2013	Capulong et al.	8,823,356 B2	9/2014	Chapman
D690,453 S	9/2013	Guercio et al.	8,824,178 B1	9/2014	Baker et al.
8,528,366 B2	9/2013	Berrada Sounni et al.	8,839,784 B2	9/2014	Wares et al.
8,530,990 B2	9/2013	Linderman et al.	8,842,454 B2	9/2014	Johnson et al.
8,534,007 B2	9/2013	Almy et al.	8,859,933 B2	10/2014	Harley et al.
8,546,681 B2	10/2013	Wares et al.	8,860,162 B2	10/2014	Linderman et al.
8,548,637 B2	10/2013	Lenox	8,860,242 B1	10/2014	Pruett et al.
8,552,288 B2	10/2013	Xavier	8,877,617 B2	11/2014	Wong et al.
8,557,093 B2	10/2013	Cousins et al.	8,878,053 B2	11/2014	Cousins
8,558,101 B2	10/2013	Mascolo et al.	8,881,415 B2	11/2014	Barton
8,563,849 B2	10/2013	Johnston et al.	8,883,247 B2	11/2014	Cousins et al.
8,567,134 B1	10/2013	Grushkowitz et al.	8,893,713 B2	11/2014	Wares et al.
8,572,836 B2	11/2013	Lenox	8,901,010 B2	12/2014	Westerberg et al.
8,580,599 B2	11/2013	Rim et al.	8,904,717 B2	12/2014	Lenox
8,584,406 B2	11/2013	Wexler et al.	8,912,038 B2	12/2014	Li et al.
8,584,667 B2	11/2013	Linderman et al.	8,922,062 B2	12/2014	Johnson et al.
8,586,397 B2	11/2013	Wu et al.	8,922,185 B2	12/2014	Ehlmann et al.
8,586,403 B2	11/2013	Harley et al.	8,929,094 B2	1/2015	Marroquin et al.
8,597,970 B2	12/2013	Cousins et al.	8,943,765 B2	2/2015	Danning et al.
8,599,587 B2	12/2013	Chapman et al.	8,945,978 B2	2/2015	Behnke
8,604,404 B1	12/2013	Linderman	8,946,541 B2	2/2015	Wares et al.
8,609,977 B2	12/2013	Jones et al.	8,955,267 B2	2/2015	Wexler et al.
8,611,107 B2	12/2013	Chapman et al.	8,956,018 B2	2/2015	Deshpande et al.
8,615,941 B2	12/2013	Botkin et al.	8,962,082 B2	2/2015	Pavani et al.
8,624,561 B1	1/2014	Slavin	8,962,373 B2	2/2015	Cousins et al.
8,624,621 B2	1/2014	Capulong et al.	8,963,185 B2	2/2015	Cousins
8,629,383 B2	1/2014	Beardsworth et al.	8,963,375 B2	2/2015	DeGraaff
8,630,077 B2	1/2014	Johnston et al.	8,964,401 B2	2/2015	Escamilla et al.
8,634,216 B2	1/2014	Chapman	8,975,175 B1	3/2015	Pass
8,636,198 B1	1/2014	Linderman et al.	8,975,717 B2	3/2015	Smith
D699,176 S *	2/2014	Salomon ..... D13/102	8,988,096 B1	3/2015	Naiknaware
8,647,911 B2	2/2014	Smith	8,991,682 B2	3/2015	Linderman et al.
8,650,813 B2	2/2014	Botkin et al.	8,992,803 B2	3/2015	Loscutoff et al.
8,656,660 B2	2/2014	Danning	9,010,041 B2	4/2015	Danning
8,658,454 B2	2/2014	Pass et al.	9,018,033 B2	4/2015	Wu et al.
D700,991 S	3/2014	Johnson et al.	9,018,516 B2	4/2015	Shepherd et al.
8,661,753 B2	3/2014	Lenox	9,020,653 B2	4/2015	Lenox
			9,029,689 B2	5/2015	Phu et al.
			9,035,167 B2	5/2015	Swanson et al.
			9,035,168 B2	5/2015	Barton
			9,035,172 B2	5/2015	Kim et al.



(56)

References Cited

U.S. PATENT DOCUMENTS

9,035,633 B1	5/2015	Slavin et al.	9,300,224 B2	3/2016	Johnson et al.
9,038,421 B2	5/2015	Berrada Sounni et al.	D754,064 S	4/2016	Mackler et al.
9,048,740 B2	6/2015	Gray et al.	9,303,285 B2	4/2016	Piazza et al.
9,054,255 B2	6/2015	Swanson et al.	9,306,085 B2	4/2016	Westerberg et al.
9,059,604 B2	6/2015	Johnson	9,312,042 B2	4/2016	Sewell et al.
9,062,854 B2	6/2015	Livesay et al.	9,312,406 B2	4/2016	Loscutoff et al.
9,065,354 B2	6/2015	Chapman et al.	9,312,425 B2	4/2016	Kim et al.
9,070,804 B2	6/2015	Cousins	9,316,417 B2	4/2016	Danning
9,077,202 B1	7/2015	Baker	9,322,437 B2	4/2016	Agullo
9,082,925 B2	7/2015	Solomon et al.	9,322,963 B2	4/2016	Linderman et al.
9,083,121 B2	7/2015	DeGraaff et al.	9,326,339 B2	4/2016	Nieberlein et al.
9,087,939 B2	7/2015	Harley et al.	9,328,427 B2	5/2016	Behnke
9,093,919 B2	7/2015	Chapman et al.	9,329,322 B2	5/2016	Yamada et al.
D736,595 S *	8/2015	Moore ..... D13/102	9,337,369 B2	5/2016	Smith
9,101,082 B1	8/2015	Dorenkamp et al.	9,342,088 B2	5/2016	Batten et al.
9,112,066 B2	8/2015	Dennis et al.	9,347,619 B2	5/2016	Schupple et al.
9,112,097 B2	8/2015	Tu	9,353,970 B2	5/2016	Linderman et al.
9,116,202 B2	8/2015	Capulong et al.	9,362,427 B2	6/2016	Sewell et al.
9,136,710 B1	9/2015	Baker et al.	D811,909 S *	3/2018	Simonton ..... D10/74
9,142,696 B2	9/2015	Loscutoff et al.	2002/0181229 A1	12/2002	Wei
9,147,795 B2	9/2015	Li et al.	2010/0276558 A1 *	11/2010	Faust ..... F24J 2/5205 248/222.14
9,153,712 B2	10/2015	Zhu	2011/0312119 A1	12/2011	Rose et al.
9,159,521 B1	10/2015	Chen et al.	2012/0134189 A1	5/2012	Krein
9,160,408 B2	10/2015	Krohne et al.	2012/0180845 A1	7/2012	Cole et al.
9,166,079 B2	10/2015	Manning	2012/0192925 A1	8/2012	Grushkowitz et al.
9,178,104 B2	11/2015	Moors et al.	2012/0216852 A1	8/2012	Almy et al.
9,184,324 B2	11/2015	Wares et al.	2013/0000694 A1	1/2013	Bunea et al.
9,184,327 B2	11/2015	Rose et al.	2013/0106196 A1	5/2013	Johnson et al.
9,185,759 B2	11/2015	Nieberlein et al.	2013/0239947 A1	9/2013	Almy et al.
9,186,741 B2	11/2015	Kumaria et al.	2013/0248668 A1 *	9/2013	Lu ..... H02S 20/00 248/222.14
9,190,839 B2	11/2015	Johnston et al.	2013/0255749 A1	10/2013	Kinyon et al.
9,193,014 B2	11/2015	Danning	2013/0305787 A1	11/2013	Berrada Sounni et al.
9,196,758 B2	11/2015	Rim et al.	2013/0340379 A1	12/2013	Danning
D744,684 S	12/2015	Guercio et al.	2013/0340380 A1	12/2013	Danning
D744,690 S	12/2015	Boyer et al.	2014/0000187 A1	1/2014	Botkin et al.
9,202,960 B2	12/2015	Luan et al.	2014/0000695 A1	1/2014	Stone
9,212,808 B2	12/2015	Higley et al.	2014/0000705 A1	1/2014	Sounni et al.
9,217,206 B2	12/2015	Behnke et al.	2014/0014499 A1	1/2014	Cousins et al.
9,219,173 B2	12/2015	Swanson et al.	2014/0034111 A1	2/2014	Bunea et al.
9,222,193 B2	12/2015	Abas et al.	2014/0034122 A1	2/2014	Cousins
9,224,902 B2	12/2015	Swanson	2014/0034455 A1	2/2014	Mulligan et al.
9,225,256 B2	12/2015	Chapman et al.	2014/0036563 A1	2/2014	Chapman et al.
9,225,285 B2	12/2015	Peurach et al.	2014/0048119 A1	2/2014	Johnston et al.
9,231,129 B2	1/2016	Harley et al.	2014/0090637 A1	4/2014	Grushkowitz
9,231,145 B2	1/2016	Smith	2014/0090638 A1	4/2014	Grushkowitz
9,239,153 B2	1/2016	Goodman et al.	2014/0090701 A1	4/2014	Rim et al.
9,240,682 B2	1/2016	Sivakumar et al.	2014/0102505 A1	4/2014	Lenox
9,243,818 B2	1/2016	Shugar et al.	2014/0102512 A1	4/2014	Jones et al.
9,246,037 B2	1/2016	Linderman	2014/0116495 A1	5/2014	Kim et al.
9,246,046 B1	1/2016	Harrington et al.	2014/0133197 A1	5/2014	Chapman
9,249,044 B2	2/2016	Judkins et al.	2014/0150846 A1	6/2014	Beardsworth et al.
9,249,523 B2	2/2016	Rim	2014/0174905 A1	6/2014	Landry
9,252,314 B2	2/2016	Wares et al.	2014/0182661 A1	7/2014	Kinyon
9,252,319 B2	2/2016	Loscutoff et al.	2014/0190561 A1	7/2014	De Ceuster et al.
9,253,935 B2	2/2016	Morris et al.	2014/0202492 A1	7/2014	Grossman et al.
9,257,575 B1	2/2016	Pass et al.	2014/0238470 A1	8/2014	Ciasulli et al.
9,257,847 B2	2/2016	Johnson et al.	2014/0261626 A1	9/2014	Ripoll Agulo
9,263,183 B2	2/2016	Chapman et al.	2014/0268908 A1	9/2014	Zhou et al.
9,263,601 B2	2/2016	Wu et al.	2014/0290715 A1	10/2014	Meydbray
9,263,602 B2	2/2016	Harley et al.	2014/0291852 A1	10/2014	Linderman et al.
9,263,622 B2	2/2016	Pass et al.	2014/0305501 A1	10/2014	Li et al.
9,263,625 B2	2/2016	Smith et al.	2014/0306092 A1	10/2014	Judkins
9,263,895 B2	2/2016	Naiknaware et al.	2014/0311054 A1	10/2014	Concho et al.
9,266,468 B2	2/2016	Mizushiro et al.	2014/0322855 A1	10/2014	Bunea
9,267,649 B2	2/2016	Janik et al.	2014/0345688 A1	11/2014	Cousins
D751,976 S	3/2016	Mackler et al.	2014/0352761 A1	12/2014	Linderman et al.
9,273,845 B2	3/2016	Eom et al.	2014/0373910 A1	12/2014	Luan et al.
9,276,635 B2	3/2016	Rothblum et al.	2015/0000724 A1	1/2015	Pass et al.
9,279,457 B2	3/2016	Grushkowitz	2015/0004737 A1	1/2015	Harley
9,279,569 B2	3/2016	Lamonato et al.	2015/0020867 A1	1/2015	Linderman et al.
9,281,419 B2	3/2016	Klein et al.	2015/0040944 A1	2/2015	Dinwoodie et al.
9,281,429 B2	3/2016	Xavier et al.	2015/0047690 A1	2/2015	Shen et al.
9,281,431 B2	3/2016	Linderman	2015/0053248 A1	2/2015	Rim et al.
9,285,081 B2	3/2016	Douglas et al.	2015/0083215 A1	3/2015	Cousins
9,293,624 B2	3/2016	Cudzinovic et al.	2015/0090328 A1	4/2015	Smith
			2015/0090329 A1	4/2015	Pass
			2015/0108692 A1	4/2015	Harley et al.

(56)

**References Cited**

U.S. PATENT DOCUMENTS

2015/0117067 A1 4/2015 Naiknaware et al.  
 2015/0122305 A1 5/2015 Marroquin et al.  
 2015/0128437 A1 5/2015 Barton  
 2015/0144197 A1 5/2015 Cousins et al.  
 2015/0146315 A1 5/2015 Wares et al.  
 2015/0155819 A1 6/2015 Wexler et al.  
 2015/0163074 A1 6/2015 Pruett et al.  
 2015/0180238 A1 6/2015 DeGraaff  
 2015/0180404 A1 6/2015 Braunstein et al.  
 2015/0194539 A1 7/2015 Shepherd et al.  
 2015/0194927 A1 7/2015 Naiknaware  
 2015/0206988 A1 7/2015 Loscutoff et al.  
 2015/0212535 A1 7/2015 Ehlmann et al.  
 2015/0214744 A1 7/2015 Lenox  
 2015/0222225 A1 8/2015 Danning  
 2015/0229221 A1 8/2015 Gray et al.  
 2015/0249405 A1 9/2015 Chapman et al.  
 2015/0249423 A1 9/2015 Braunstein et al.  
 2015/0263200 A1 9/2015 Dennis et al.  
 2015/0270803 A1 9/2015 Barton  
 2015/0280038 A1 10/2015 Sethi et al.  
 2015/0282365 A1 10/2015 Escamilla et al.  
 2015/0287875 A1 10/2015 Phu et al.  
 2015/0288328 A1 10/2015 Swanson et al.  
 2015/0311357 A1 10/2015 Harley et al.  
 2015/0325710 A1 11/2015 Tu  
 2015/0326168 A1 11/2015 Johnson  
 2015/0326178 A1 11/2015 Capulong et al.  
 2015/0333617 A1 11/2015 Chapman et al.  
 2015/0340868 A1 11/2015 Chapman  
 2015/0342084 A1 11/2015 Dorenkamp et al.  
 2015/0349158 A1 12/2015 Manning  
 2015/0349706 A1 12/2015 Grossman et al.  
 2015/0349709 A1 12/2015 Ponec et al.  
 2015/0364625 A1 12/2015 Solomon et al.

2015/0372638 A1 12/2015 Degraaff et al.  
 2015/0377518 A1 12/2015 Maxey et al.  
 2015/0380578 A1 12/2015 Zhu  
 2016/0011246 A1 1/2016 Fischer et al.  
 2016/0020827 A1 1/2016 Krohne et al.  
 2016/0027953 A1 1/2016 Moors et al.  
 2016/0028345 A1 1/2016 Wares et al.  
 2016/0035908 A1 2/2016 Rose et al.  
 2016/0036380 A1 2/2016 Johnston et al.  
 2016/0043267 A1 2/2016 Rim et al.  
 2016/0043684 A1 2/2016 Harif  
 2016/0064576 A1 3/2016 Luan et al.  
 2016/0065119 A1 3/2016 Danning  
 2016/0071991 A1 3/2016 Smith  
 2016/0071996 A1 3/2016 Swanson et al.  
 2016/0071999 A1 3/2016 Loscutoff et al.  
 2016/0079450 A1 3/2016 Harley et al.  
 2016/0079911 A1 3/2016 Rose et al.  
 2016/0087425 A1 3/2016 Sivakumar et al.  
 2016/0090662 A1 3/2016 Capulong et al.  
 2016/0105027 A1 4/2016 Johnson et al.  
 2016/0108541 A1 4/2016 Abas et al.  
 2016/0111583 A1 4/2016 Harrington et al.  
 2016/0112003 A1 4/2016 Morris et al.  
 2016/0118516 A1 4/2016 Harley et al.  
 2016/0133759 A1 5/2016 Pass et al.  
 2016/0133767 A1 5/2016 Smith et al.  
 2016/0134233 A1 5/2016 Chapman et al.  
 2016/0142100 A1 5/2016 Rothblum et al.  
 2016/0156309 A1 6/2016 Almogy et al.  
 2016/0164300 A1 6/2016 Johnson et al.  
 2016/0164427 A1 6/2016 Chapman et al.

OTHER PUBLICATIONS

Flex Lighting Solutions Specification Sheets, Essentials Series, Published May 2017 (9 pages).

\* cited by examiner



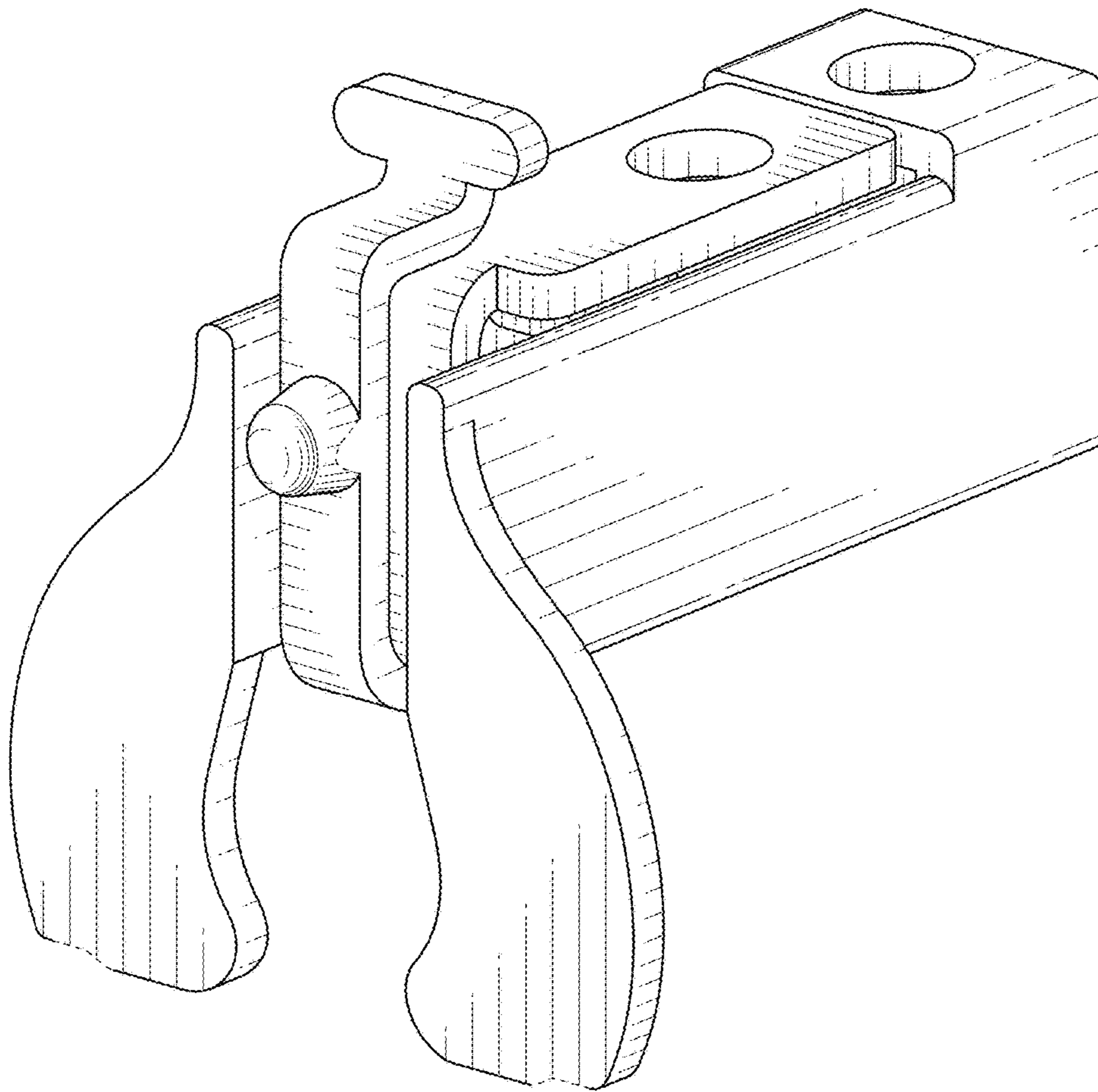

FIG. 1

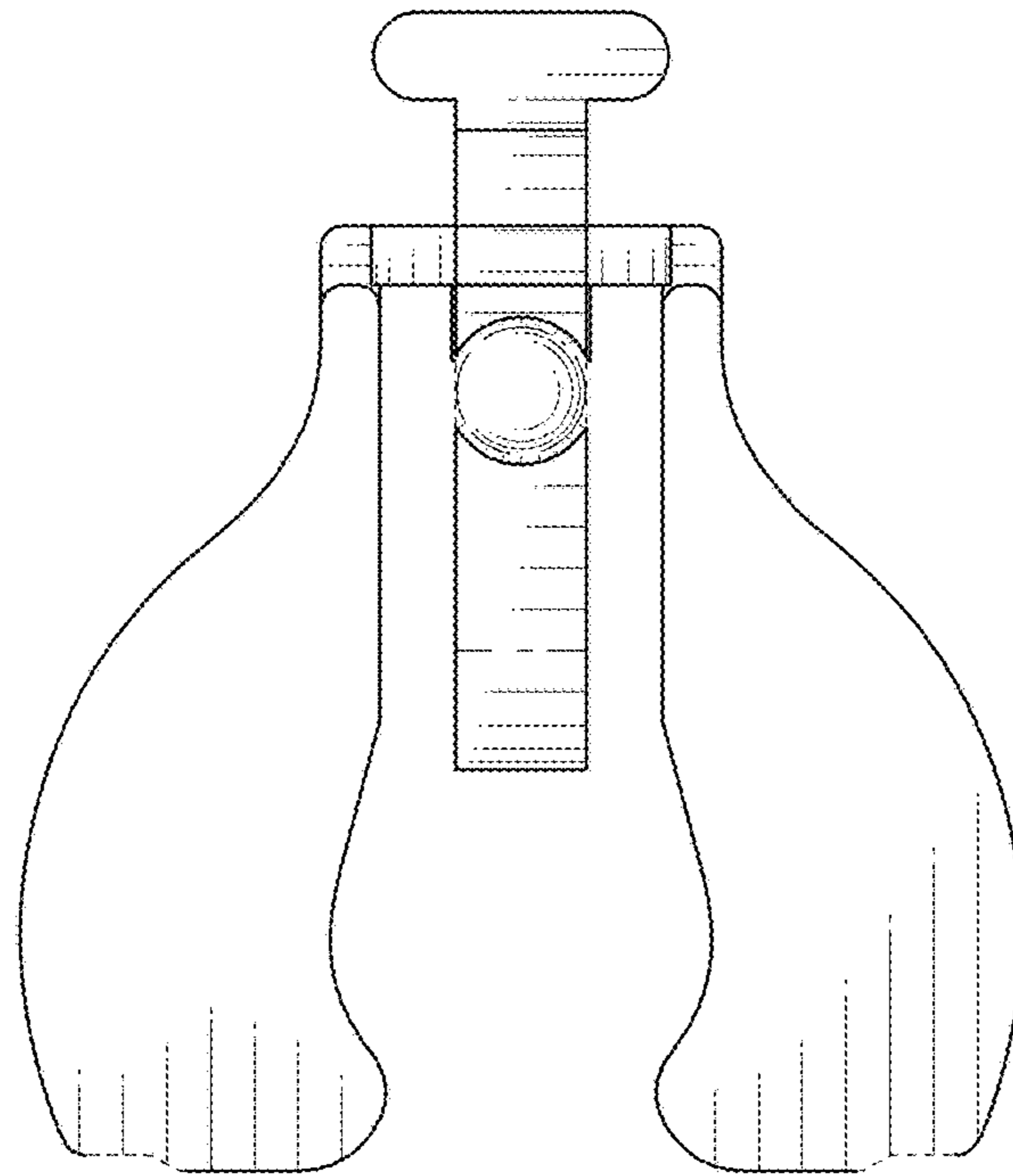

FIG. 2

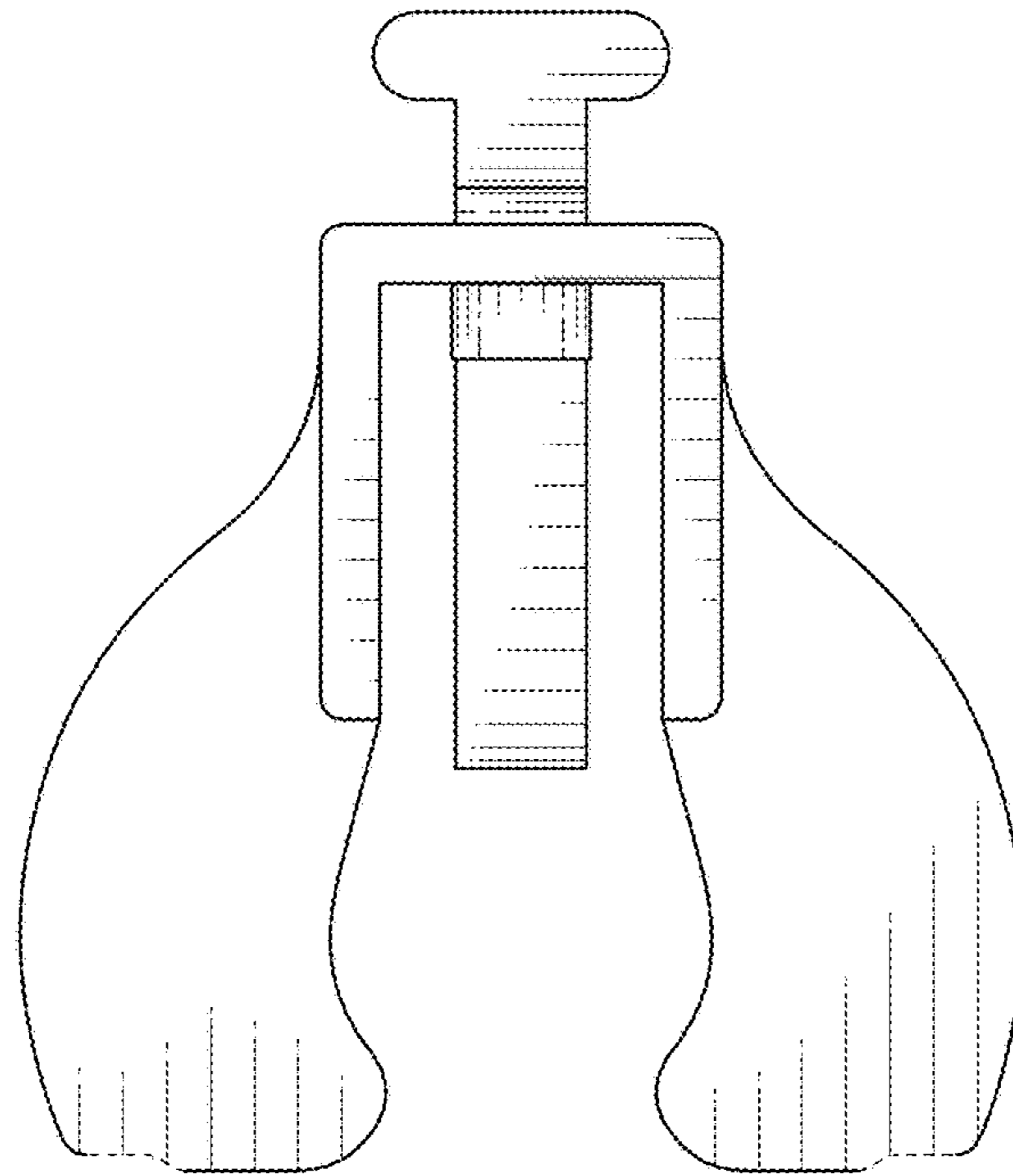

FIG. 3

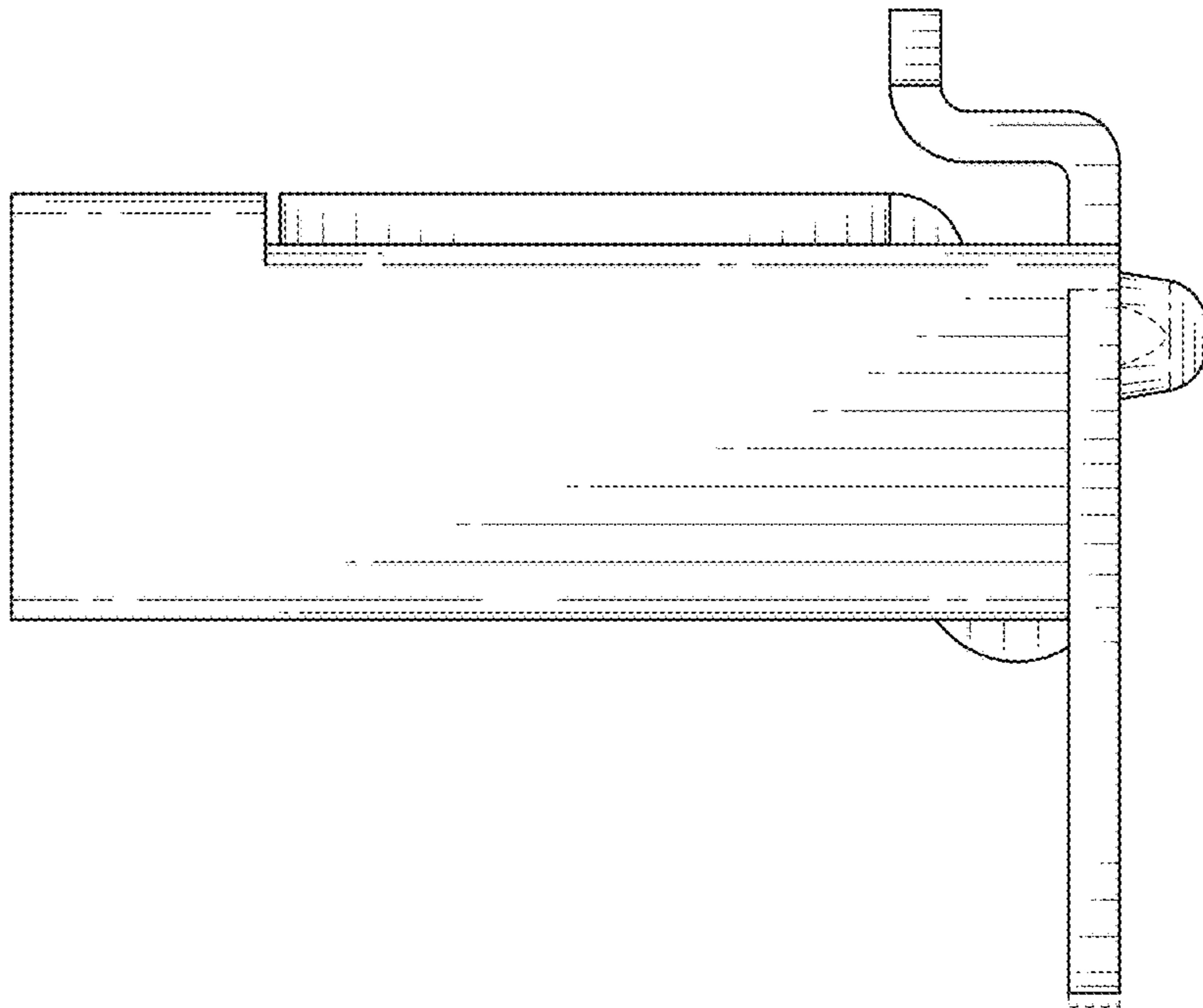

FIG. 4

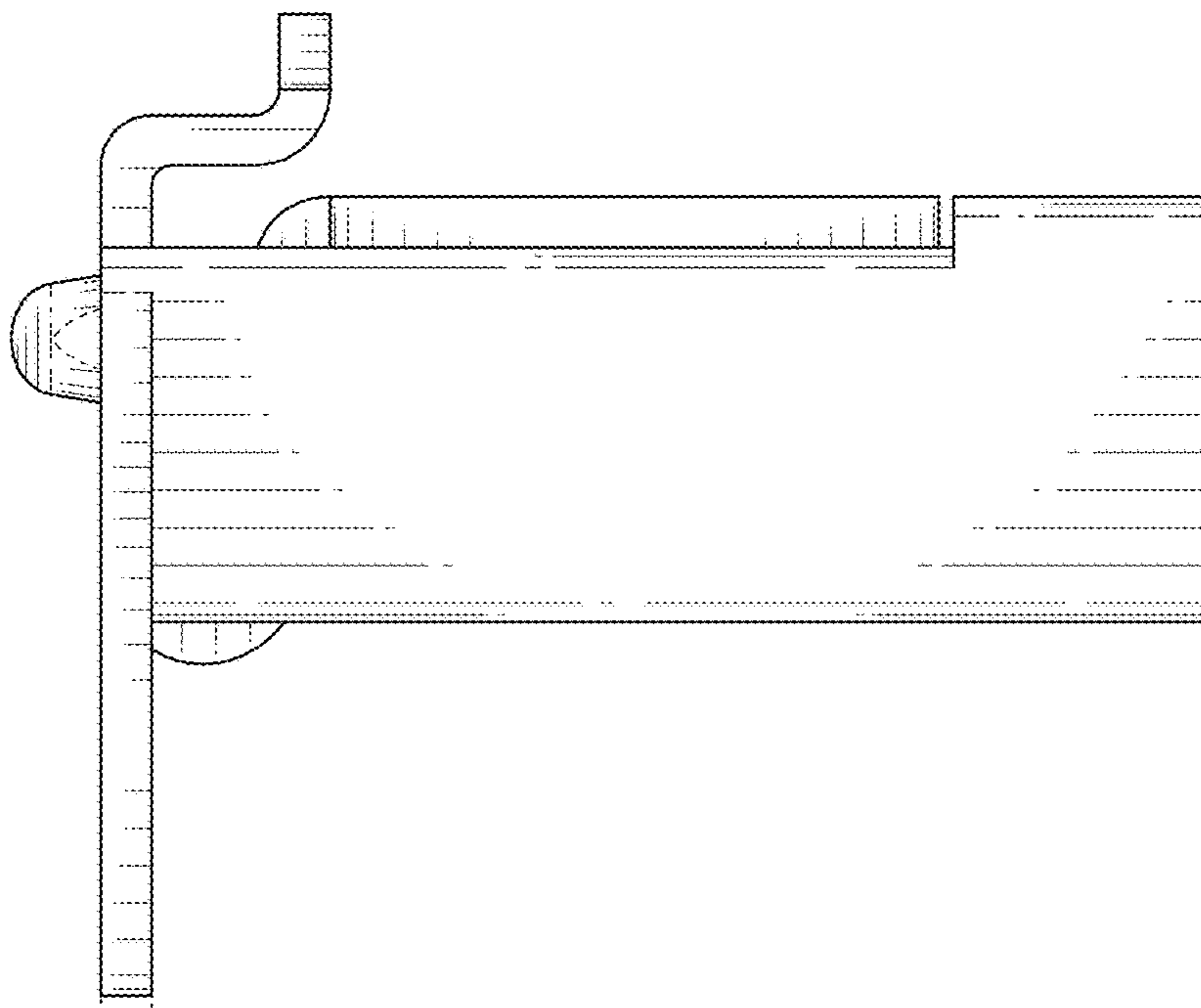

FIG. 5



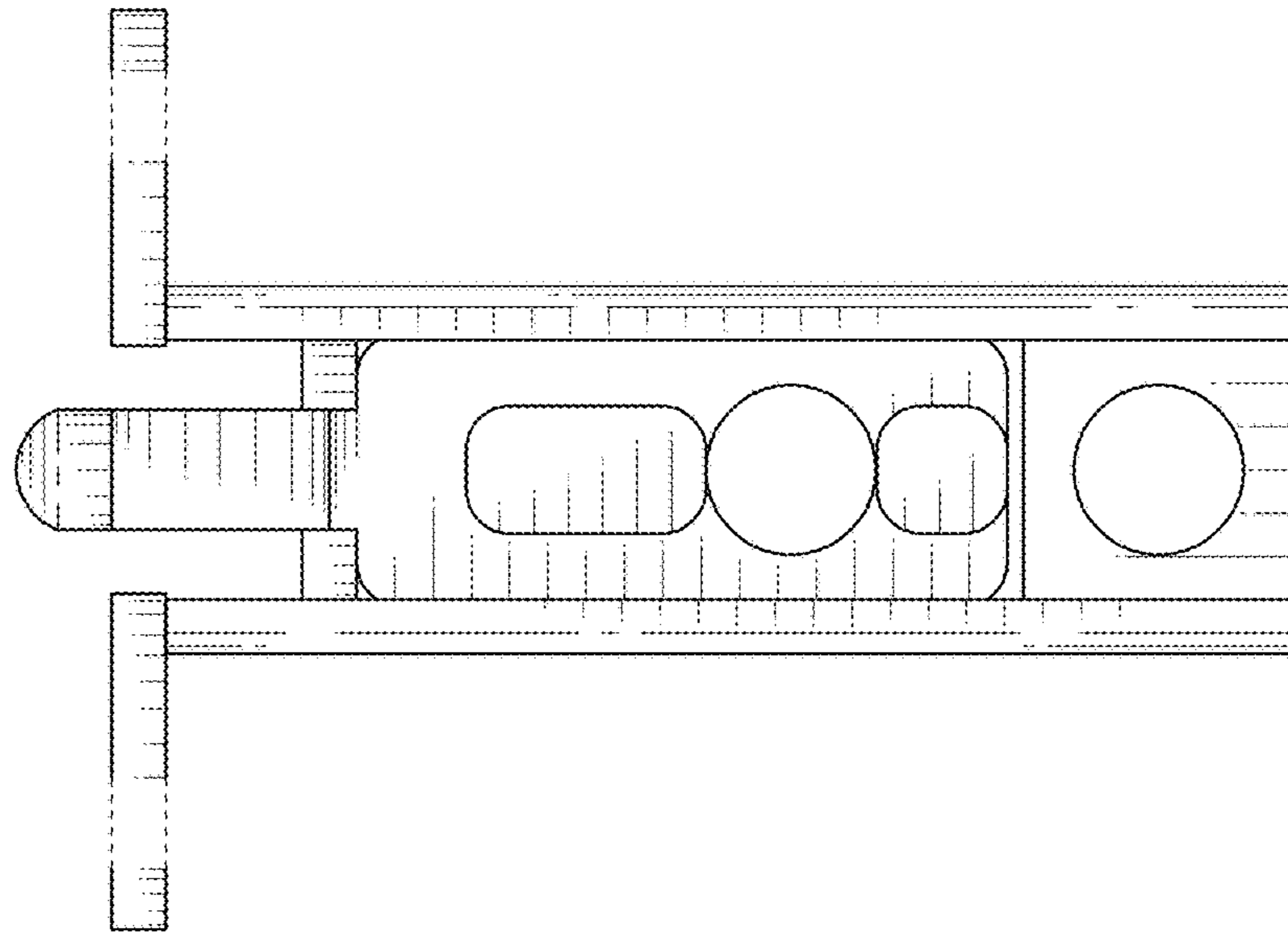

FIG. 7

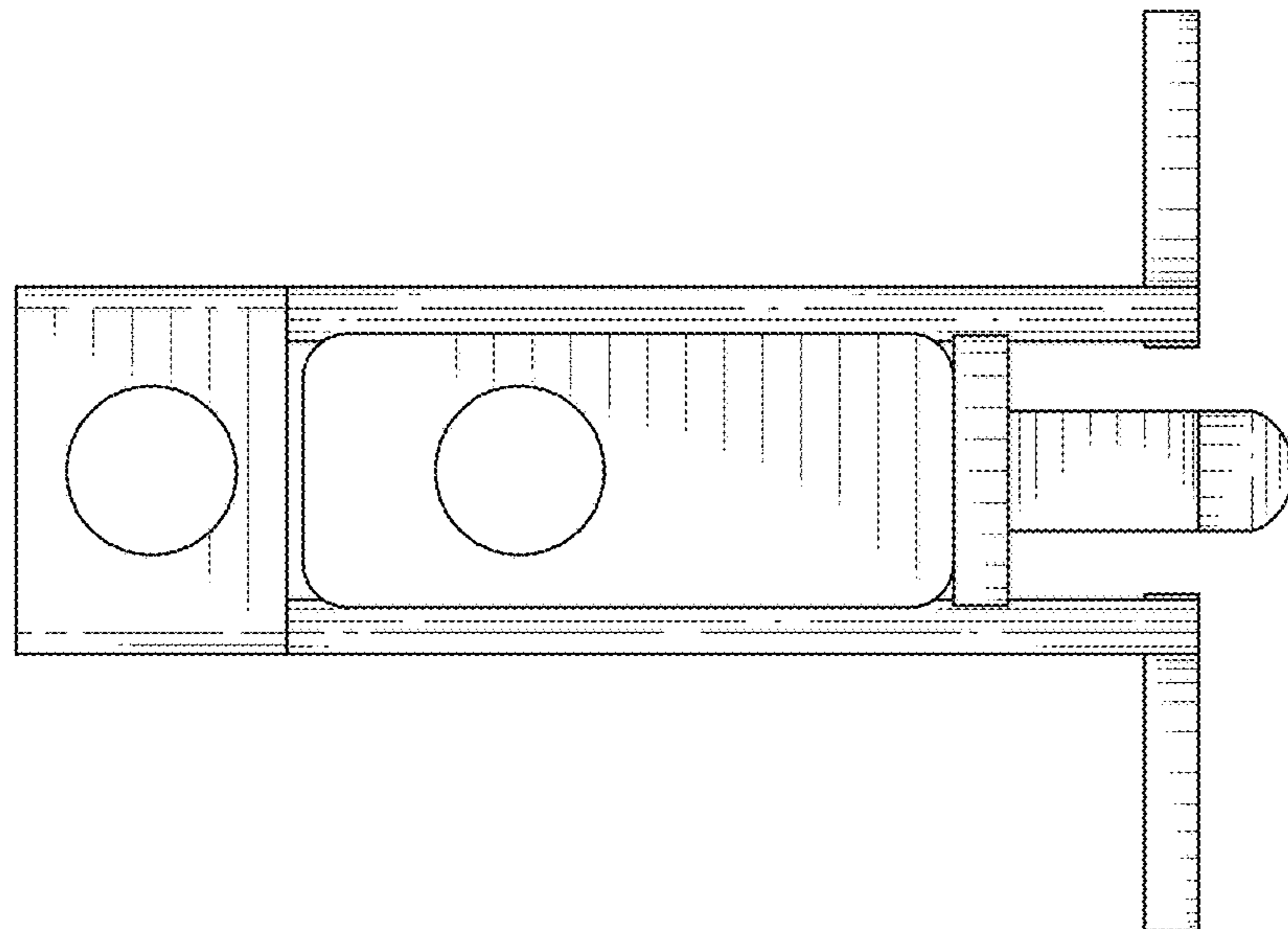

FIG. 6

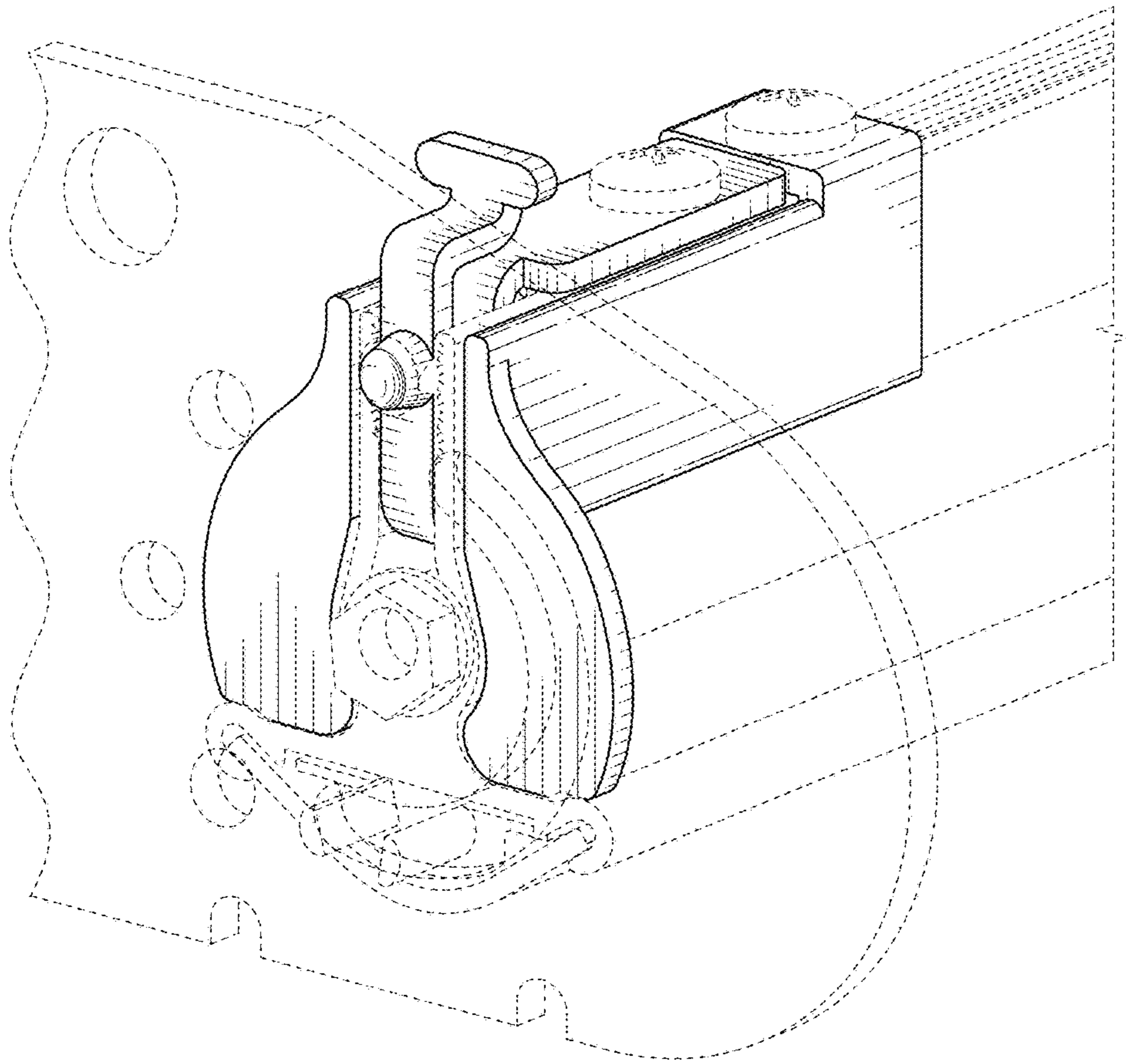

FIG. 8