



US00D846452S

(12) **United States Design Patent**
Collins et al.

(10) **Patent No.:** **US D846,452 S**
(45) **Date of Patent:** **** Apr. 23, 2019**

(54) **DISPLAY HOUSING**

(71) Applicant: **DEKA Products Limited Partnership**,
Manchester, NH (US)

(72) Inventors: **David E. Collins**, Merrimac, MA (US);
Katie A. DeLaurentis, Manchester, NH
(US); **Alexander D. Streeter**, Concord,
NH (US)

(73) Assignee: **DEKA Products Limited Partnership**,
Manchester, NH (US)

(**) Term: **15 Years**

(21) Appl. No.: **29/604,817**

(22) Filed: **May 20, 2017**

(51) **LOC (11) Cl.** **12-12**

(52) **U.S. Cl.**
USPC **D12/133; D14/388**

(58) **Field of Classification Search**
USPC D12/128-133, 274, 277, 415, 345;
D14/388, 389, 390, 318, 341, 342, 346,
D14/356, 130, 218, 454, 455, 299, 371,
D14/374, 378, 496, 432, 434, 457, 458,
D14/412, 413; D13/162, 162.1, 136, 164,
D13/168; D10/46, 61, 65; D19/59-61,
D19/113; D20/10, 11, 19, 99; D21/324,
D21/329, 333
CPC G06F 3/041; G06F 3/0412; G06F 3/0414;
G06F 3/0416; G06F 3/044; G06F 3/048;
G06F 3/484; G06F 3/488; G06F 3/4883;
G06F 3/03545; G06F 2203/0338; G06F
1/1669; G06F 1/1643; G06F 1/166; A61G
5/00-5/14

See application file for complete search history.

(56) **References Cited**

U.S. PATENT DOCUMENTS

584,127 A 6/1897 Draullette et al.
849,270 A 4/1907 Schafer
880,823 A 3/1908 Redfield

2,224,411 A 12/1940 Smith
2,415,056 A 1/1947 Wheeler
2,618,447 A 11/1952 Lecarme
2,742,973 A 4/1956 Johannesen
2,966,223 A 12/1960 Gleasman
3,017,199 A 1/1962 Sechrist
3,145,797 A 8/1964 Taylor
3,179,355 A 4/1965 Pickering
3,260,324 A 7/1966 Suarez
3,283,398 A 11/1966 Andren
3,288,234 A 11/1966 Feliz
3,306,626 A 2/1967 Kawada
3,313,365 A 4/1967 Jackson
3,338,328 A 8/1967 Cataldo
3,348,518 A 10/1967 Forsyth
3,374,845 A 3/1968 Selwyn
3,399,742 A 9/1968 Malick
3,446,304 A 5/1969 Alimanestiand
3,450,219 A 6/1969 Fleming
3,515,401 A 6/1970 Gross
3,580,344 A 5/1971 Floyd
3,596,298 A 8/1971 Durst, Jr.
3,628,624 A 12/1971 Wesener
3,718,342 A 2/1973 Freed
3,787,066 A 1/1974 Hautier
3,790,150 A 2/1974 Lippert
3,860,264 A 1/1975 Douglas
3,872,945 A 3/1975 Hickman
3,893,689 A 7/1975 Verhoff
3,952,822 A 4/1976 Udden
3,965,402 A 6/1976 Mogle
3,993,154 A 11/1976 Simmons et al.
4,005,907 A 2/1977 Bonomo
4,018,440 A 4/1977 Deutsch
4,030,753 A 6/1977 Meiners
4,054,319 A 10/1977 Fogg et al.
4,062,558 A 12/1977 Wasserman
4,065,145 A 12/1977 Chambers
4,065,146 A 12/1977 Denzer
4,076,270 A 2/1978 Winchell
4,078,627 A 3/1978 Brown et al.
4,087,107 A 5/1978 Winchell
4,088,199 A 5/1978 Trautwein
4,094,372 A 6/1978 Notter
4,109,741 A 8/1978 Gabriel
4,111,445 A 9/1978 Haibeck
4,115,445 A 9/1978 Harsey
4,140,200 A 2/1979 Tucek
4,151,892 A 5/1979 Francken
D253,234 S * 10/1979 Cooke D13/168
4,222,449 A 9/1980 Feliz
4,264,082 A 4/1981 Fouchey, Jr.
4,266,627 A 5/1981 Lauber

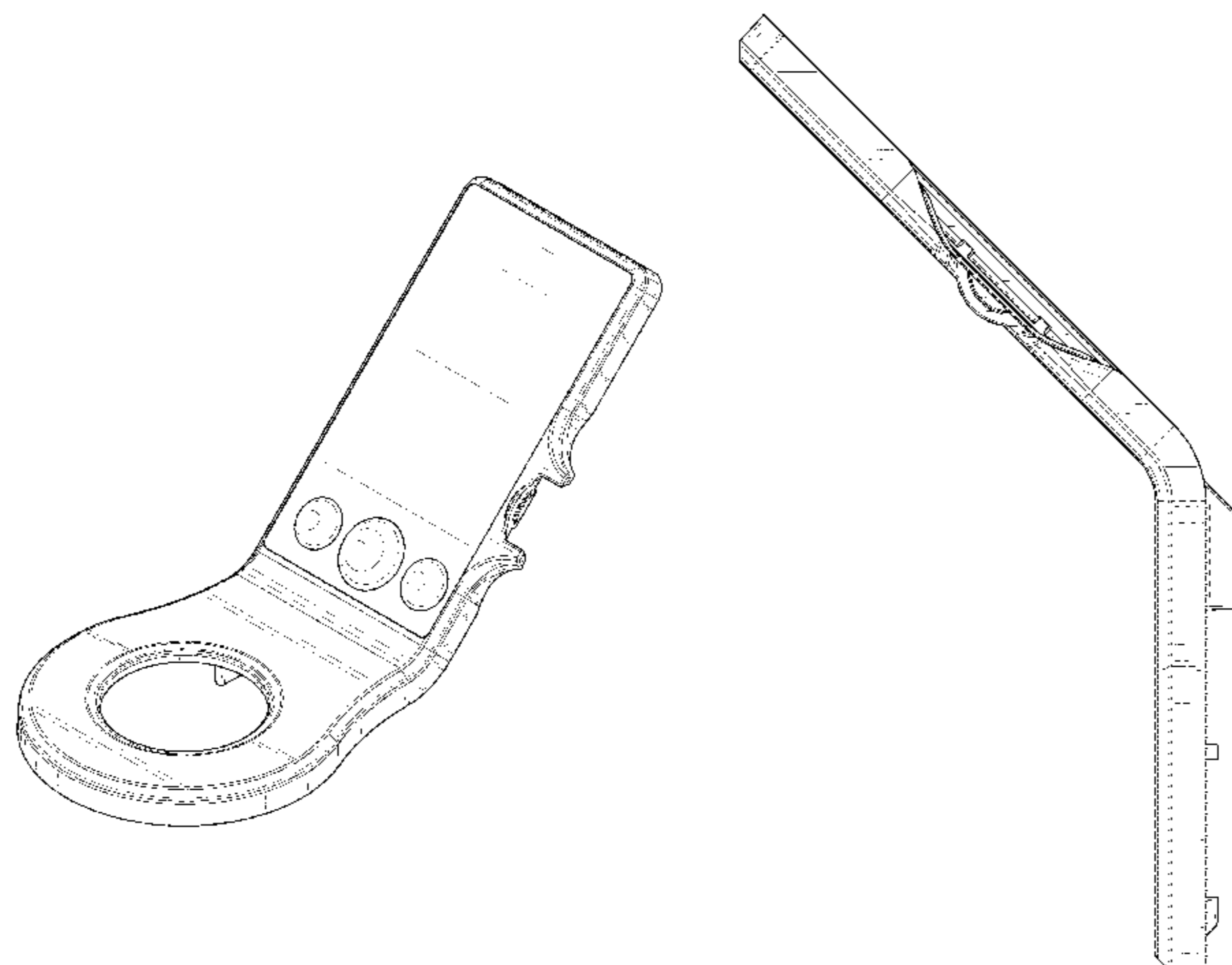

US D846,452 S

4,274,503 A	6/1981	Mackintosh		5,136,219 A	8/1992	Takahashi
4,281,734 A	8/1981	Johnston		5,158,493 A	10/1992	Morgrey
4,293,052 A	10/1981	Daswick		5,161,820 A	11/1992	Vollmer
4,307,788 A	12/1981	Shelton		5,165,711 A	11/1992	Tsai
4,325,565 A	4/1982	Winchell		5,168,947 A	12/1992	Rodenborn
4,354,569 A	10/1982	Eichholz		5,171,173 A	12/1992	Henderson
D266,758 S *	11/1982	Johannsen	D13/168	5,186,270 A	2/1993	West
4,363,493 A	12/1982	Veneklasen		5,208,521 A	5/1993	Aoyama
4,373,600 A	2/1983	Buschbom		5,217,246 A	6/1993	Williams
4,375,840 A	3/1983	Campbell		5,221,883 A	6/1993	Takenaka
4,413,693 A	11/1983	Derby		5,229,068 A	7/1993	Johansson et al.
4,448,455 A	5/1984	Ellegaard		5,241,875 A	9/1993	Kochanneck
4,456,086 A	6/1984	Wier		5,248,007 A	9/1993	Watkins
4,484,648 A	11/1984	Jephcott		5,261,503 A	11/1993	Yasui
4,510,956 A	4/1985	King		5,274,576 A	12/1993	Williams
4,512,588 A	4/1985	Cox		5,276,588 A	1/1994	Replinger
4,556,997 A	12/1985	Takamiya		5,276,624 A	1/1994	Ito
4,560,022 A	12/1985	Kassai		5,297,646 A	3/1994	Yamamura
4,566,707 A	1/1986	Nitzberg		5,307,888 A	5/1994	Urvoy
4,570,078 A	2/1986	Yashima		5,307,892 A	5/1994	Phillips
4,571,844 A	2/1986	Komasaku		5,314,034 A	5/1994	Chittal
4,624,469 A	11/1986	Bourne, Jr.		5,350,033 A	9/1994	Kraft
4,648,783 A	3/1987	Tan		5,366,036 A	11/1994	Perry
4,657,271 A	4/1987	Salmon		5,369,580 A	11/1994	Monji
4,657,272 A	4/1987	Davenport		5,376,868 A	12/1994	Toyoda
4,685,693 A	8/1987	Vadjunec		D355,148 S	2/1995	Orsolini
4,709,772 A	12/1987	Brunet		5,388,658 A	2/1995	Ando et al.
4,712,806 A	12/1987	Patrin		5,397,890 A	3/1995	Schueler
4,716,980 A	1/1988	Butler		5,408,411 A	4/1995	Nakamura
4,722,547 A	2/1988	Kishi		5,408,811 A	4/1995	Satake
4,732,353 A	3/1988	Studer		5,417,298 A	5/1995	Shibahata
4,740,001 A	4/1988	Torleumke		5,419,624 A	5/1995	Adler
4,746,132 A	5/1988	Eagan		5,450,919 A	9/1995	Shitani
4,750,578 A	6/1988	Brandenfels		5,465,806 A	11/1995	Higasa
4,770,410 A	9/1988	Brown		5,482,125 A	1/1996	Pagett
4,778,133 A	10/1988	Sakurai		D373,121 S	8/1996	Deiuliis et al.
4,786,069 A	11/1988	Tang		5,551,756 A	9/1996	Gurasich et al.
4,787,679 A	11/1988	Arnold		5,576,959 A	11/1996	Hrovat
4,790,400 A	12/1988	Sheeter		D376,585 S	12/1996	Wathen et al.
4,790,548 A	12/1988	Decelles		5,615,116 A	3/1997	Gudat
4,794,730 A	1/1989	Fischbach		D381,325 S *	7/1997	McMahan D14/388
4,794,999 A	1/1989	Hester		5,646,845 A	7/1997	Gudat
4,798,255 A	1/1989	Wu		5,649,605 A	7/1997	Ronne et al.
4,802,542 A	2/1989	Houston		5,657,828 A	8/1997	Nagamachi
4,809,804 A	3/1989	Houston		5,695,021 A	12/1997	Schaffner
4,834,200 A	5/1989	Kajita		5,701,965 A	12/1997	Kamen
4,837,694 A	6/1989	Narita et al.		5,701,968 A	12/1997	Wright-Ott
4,863,182 A	9/1989	Chern		5,705,746 A	1/1998	Trost
4,867,188 A	9/1989	Reid		5,732,379 A	3/1998	Eckert
4,869,279 A	9/1989	Hedges		5,743,347 A	4/1998	Gingerich
4,874,055 A	10/1989	Beer		5,746,282 A	5/1998	Fujiwara
4,890,853 A	1/1990	Olson		5,769,441 A	6/1998	Namngani
4,897,070 A	1/1990	Wagstaff		5,774,819 A	6/1998	Yamamoto et al.
4,913,252 A	4/1990	Bartley et al.		5,775,452 A	7/1998	Patmont
4,919,225 A	4/1990	Sturges		5,791,425 A	8/1998	Kamen
D308,364 S *	6/1990	Beasley, Jr.	D14/389	5,794,730 A	8/1998	Kamen
4,941,854 A	7/1990	Takahashi et al.		5,799,745 A	9/1998	Fukatani
4,944,360 A	7/1990	Sturges		5,799,914 A	9/1998	Chivallier et al.
4,953,851 A	9/1990	Sherlock		5,826,209 A	10/1998	Matsuno
4,964,679 A	10/1990	Rath		D402,645 S	12/1998	Garguilo
4,967,862 A	11/1990	Pong et al.		5,848,660 A	12/1998	McGreen
4,973,071 A	11/1990	Ishizaki		5,850,136 A	12/1998	Kaneko
4,984,754 A	1/1991	Yarrington		5,869,943 A	2/1999	Nakashima et al.
4,985,947 A	1/1991	Ethridge		5,869,946 A	2/1999	Carobolante
4,998,596 A	3/1991	Miksitz		5,893,896 A	4/1999	Imamura et al.
5,001,636 A	3/1991	Shiraishi et al.		5,927,414 A	7/1999	Kan et al.
5,002,295 A	3/1991	Lin		5,928,309 A	7/1999	Korver
5,011,171 A	4/1991	Cook		5,931,421 A	8/1999	Surauer et al.
5,012,176 A	4/1991	Laforge		5,939,864 A	8/1999	Lenhart et al.
RE33,675 E	8/1991	Young		5,965,991 A	10/1999	Koike
5,044,457 A	9/1991	Aikman		5,971,091 A	10/1999	Kamen
5,052,237 A	10/1991	Reimann		5,973,463 A	10/1999	Okuda
5,076,390 A	12/1991	Haskins		5,975,225 A	11/1999	Kamen
5,087,103 A	2/1992	Pompier		5,986,221 A	11/1999	Stanley
5,088,761 A	2/1992	Takehara et al.		6,002,975 A	12/1999	Schiffmann
5,098,041 A	3/1992	Utrecht		6,003,624 A	12/1999	Jorgensen
5,111,899 A	5/1992	Reimann		6,024,182 A	2/2000	Hamada et al.
5,124,938 A	6/1992	Algrain		6,036,619 A	3/2000	Tashiro
5,125,468 A	6/1992	Coker		6,039,142 A	3/2000	Eckstein

US D846,452 S

6,050,357 A	4/2000	Staelin	6,571,176 B1	5/2003	Shinmura
6,052,647 A	4/2000	Parkinson	6,571,892 B2	6/2003	Kamen
6,053,579 A	4/2000	Nelson et al.	6,575,539 B2	6/2003	Reich
6,059,062 A	5/2000	Staelin	6,581,714 B1	6/2003	Kamen
6,062,600 A	5/2000	Kamen et al.	6,582,181 B2	6/2003	Suehiro et al.
6,062,651 A	5/2000	Schaad	6,586,901 B1	7/2003	Singer et al.
6,065,558 A	5/2000	Wielenga	6,593,849 B2	7/2003	Chubb
6,076,033 A	6/2000	Hamada	6,598,941 B2	7/2003	Field et al.
6,089,680 A	7/2000	Yoshioka et al.	6,614,343 B1	9/2003	Fennel
6,092,249 A	7/2000	Kamen et al.	6,615,938 B2	9/2003	Morrell et al.
D428,936 S *	8/2000	Serfaty D21/329	6,634,451 B2	10/2003	Sakakiyama
6,105,704 A	8/2000	Hamada	6,643,451 B1	11/2003	Tokura et al.
6,123,398 A	9/2000	Arai	6,647,248 B1	11/2003	Ortscheid et al.
6,125,953 A	10/2000	Arai	6,651,763 B1	11/2003	Kamen et al.
6,125,957 A	10/2000	Kauffmann	6,654,674 B2	11/2003	Lu
6,131,057 A	10/2000	Tamaki	6,654,675 B2	11/2003	Pedersen et al.
6,141,613 A	10/2000	Fan	6,659,211 B2	12/2003	Esposito
6,148,939 A	11/2000	Brookhart	6,659,570 B2	12/2003	Nakamura
6,154,692 A	11/2000	Cielaszyk	D485,279 S	1/2004	Decombe
D434,762 S *	12/2000	Ikenaga D14/218	6,694,225 B2	2/2004	Aga
6,169,946 B1	1/2001	Griessbach	6,704,622 B2	3/2004	Tinsky
6,189,643 B1	2/2001	Takahashi	6,713,693 B1	3/2004	Sadowski
6,192,305 B1	2/2001	Schiffmann	D489,027 S	4/2004	Waters
6,208,734 B1	3/2001	Ortscheid et al.	D489,029 S	4/2004	Waters
6,208,929 B1	3/2001	Matsuno et al.	D489,300 S	5/2004	Chang
6,212,276 B1	4/2001	Inoue	6,752,231 B2	6/2004	Hume
6,223,104 B1	4/2001	Kamen	D493,127 S	7/2004	Waters
6,223,114 B1	4/2001	Boros	D493,128 S	7/2004	Waters
6,225,977 B1	5/2001	Li	D493,801 S	8/2004	Byun
D444,184 S	6/2001	Kettler	D494,099 S	8/2004	Maurer
6,247,548 B1	6/2001	Hayashi	6,779,621 B2	8/2004	Kamen et al.
6,260,646 B1	7/2001	Fernandez et al.	6,781,960 B1	8/2004	Charas
6,263,261 B1	7/2001	Brown	6,789,640 B1	9/2004	Arling
6,273,212 B1	8/2001	Husted et al.	6,793,258 B2	9/2004	Gray
6,276,471 B1	8/2001	Kratzenberg et al.	6,796,396 B2	9/2004	Kamen
6,288,505 B1	9/2001	Heinzmann	6,799,649 B2	10/2004	Kamen et al.
6,292,722 B1	9/2001	Holmes et al.	6,827,163 B2	12/2004	Amsbury et al.
6,302,230 B1	10/2001	Kamen	D503,402 S *	3/2005	Su D14/388
6,311,794 B1	11/2001	Morrell et al.	6,866,107 B2	3/2005	Heinzmann et al.
6,320,336 B1	11/2001	Eguchi	6,868,931 B2	3/2005	Morrell
6,324,446 B1	11/2001	Brown et al.	D503,928 S	4/2005	Obata
6,325,736 B1	12/2001	Hamada	6,874,591 B2	4/2005	Morrell et al.
6,328,125 B1	12/2001	Van Den Brink	6,889,784 B2	5/2005	Troll
6,332,103 B1	12/2001	Steenon, Jr.	6,907,949 B1	6/2005	Wang
6,332,104 B1	12/2001	Brown	D507,206 S	7/2005	Wang
6,343,664 B2	2/2002	Morrell et al.	6,920,947 B2	7/2005	Kamen et al.
6,356,188 B1	3/2002	Meyers	6,938,923 B2	9/2005	Mulhern et al.
6,357,544 B1	3/2002	Kamen	6,962,383 B2	11/2005	Takenoshita et al.
6,360,996 B1	3/2002	Bockman et al.	6,965,206 B2	11/2005	Kamen et al.
6,367,817 B1	4/2002	Kamen	6,969,079 B2	11/2005	Kamen et al.
6,371,228 B1	4/2002	Husted et al.	7,000,933 B2	2/2006	Arling et al.
6,377,906 B1	4/2002	Rowe	7,004,271 B1	2/2006	Kamen et al.
6,386,576 B1	5/2002	Kamen et al.	7,006,901 B2	2/2006	Wang
6,388,580 B1	5/2002	Graham	D517,086 S	3/2006	Siebel
6,397,046 B1	5/2002	Kfoury	7,017,686 B2	3/2006	Kamen et al.
6,405,816 B1	6/2002	Kamen et al.	D521,017 S	5/2006	Jewitt
6,408,240 B1	6/2002	Morrell et al.	7,040,713 B2	5/2006	Rudolf
6,415,215 B1	7/2002	Nishizaki	D524,315 S	7/2006	Reusing
6,415,879 B2	7/2002	Kamen et al.	7,090,040 B2	8/2006	Kamen et al.
6,416,272 B1	7/2002	Suehiro	D528,468 S	9/2006	Arling
6,435,535 B1	8/2002	Field	D529,005 S *	9/2006	Hong D14/126
6,435,538 B2	8/2002	Ellis	7,102,328 B2	9/2006	Long et al.
6,443,250 B1	9/2002	Kamen et al.	7,130,702 B2	10/2006	Morrell
6,443,251 B1	9/2002	Morrell et al.	7,174,976 B2	2/2007	Kamen et al.
6,463,369 B2	10/2002	Sadano	7,178,611 B2	2/2007	Zupanick
D466,122 S	11/2002	Moody	7,178,614 B2	2/2007	Ishii
6,484,829 B1	11/2002	Cox	7,182,166 B2	2/2007	Gray et al.
D466,516 S	12/2002	Peiker	D539,810 S	4/2007	Cummins
6,502,011 B2	12/2002	Haag	7,198,223 B2	4/2007	Phelps, III et al.
6,508,319 B1	1/2003	Langenfeld et al.	7,210,544 B2	5/2007	Kamen et al.
6,538,411 B1	3/2003	Field	7,219,912 B2	5/2007	Meyer
6,543,564 B1	4/2003	Kamen	D544,486 S	6/2007	Hussaini
6,543,848 B1	4/2003	Suga et al.	7,234,779 B2	6/2007	Bedford et al.
6,543,858 B1	4/2003	Melton	D546,782 S *	7/2007	Poulet D13/168
6,547,026 B2	4/2003	Kamen et al.	D549,721 S	8/2007	Ito
6,553,271 B1	4/2003	Morrell	D551,592 S	9/2007	Chang et al.
6,556,909 B2	4/2003	Matsumoto	D551,722 S	9/2007	Chang et al.
6,561,294 B1	5/2003	Kamen	7,273,116 B2	9/2007	Kamen et al.
6,562,511 B2	5/2003	Daroux	D552,609 S	10/2007	Kornblum

US D846,452 S

7,275,607 B2	10/2007	Kamen et al.		8,690,265 B2	4/2014	Noblanc	
D556,149 S *	11/2007	Kaufhold	D13/162	D704,621 S *	5/2014	Taylor	D12/197
D557,220 S *	12/2007	Ewringmann	D13/164	D705,799 S	5/2014	Funabashi	
D557,221 S *	12/2007	Ewringmann	D13/164	8,738,238 B2	5/2014	Rekow	
7,303,032 B2	12/2007	Kahlert et al.		8,738,278 B2	5/2014	Chen	
7,316,441 B2	1/2008	Iwatani et al.		D706,807 S	6/2014	Harre	
D564,033 S *	3/2008	Itskov	D21/329	D707,701 S	6/2014	D'amore	
7,363,993 B2	4/2008	Ishii		8,753,208 B2	6/2014	Jaouen et al.	
7,370,713 B1	5/2008	Kamen		D708,203 S	7/2014	Johnson	
7,399,035 B2	7/2008	Kusanagi et al.		8,807,250 B2	8/2014	Chen	
7,481,291 B2	1/2009	Nishikawa		8,830,048 B2	9/2014	Kamen et al.	
D585,906 S	2/2009	Berg		8,832,875 B2	9/2014	Odashima et al.	
D587,660 S	3/2009	Lin		D716,325 S	10/2014	Brudnicki	
7,546,889 B2	6/2009	Kamen et al.		8,860,551 B2	10/2014	Carraher	
D598,927 S	8/2009	Hirsch		D716,818 S	11/2014	Alegiani	
7,589,643 B2	9/2009	Dagci		8,925,563 B2	1/2015	Ota et al.	
7,592,900 B2	9/2009	Kamen et al.		8,958,976 B2	2/2015	Kajima	
D601,922 S	10/2009	Imai et al.		D723,558 S	3/2015	Downs	
7,640,086 B2	12/2009	Nakashima et al.		8,978,791 B2	3/2015	Ha	
7,688,191 B2	3/2010	Lu		9,016,410 B2	4/2015	Trowell et al.	
7,690,447 B2	4/2010	Kamen et al.		D729,270 S	5/2015	Clare	
7,690,452 B2	4/2010	Kamen et al.		D729,833 S	5/2015	Clare	
7,703,568 B2	4/2010	Ishii		9,038,212 B2	5/2015	Yamaguchi et al.	
D614,998 S	5/2010	Fujita		D732,062 S	6/2015	Kwon	
7,740,099 B2	6/2010	Field et al.		9,045,190 B2	6/2015	Chen	
7,757,794 B2	7/2010	Heinzmann		D738,907 S	9/2015	Cabrera-Cordon	
7,789,174 B2	9/2010	Kamen		D738,913 S	9/2015	Cabrera-Cordon	
7,823,676 B2	11/2010	Yamada et al.		9,126,497 B2	9/2015	Heinzmann	
7,857,088 B2	12/2010	Field		9,156,516 B2	10/2015	Kahlert	
D632,229 S	2/2011	Kruse		D742,300 S *	11/2015	Fontaeus	D12/415
7,896,440 B2	3/2011	Tsai		D742,407 S	11/2015	Park	
7,900,725 B2	3/2011	Heinzmann et al.		D742,795 S	11/2015	Siao	
7,917,097 B2	3/2011	Hawkins et al.		D750,179 S *	2/2016	Foulkes	D14/400
7,958,956 B2	6/2011	Kakinuma et al.		D752,572 S *	3/2016	Kohler	D14/302
8,011,459 B2	9/2011	Serai		D755,785 S *	5/2016	Sirotych	D14/341
8,014,923 B2	9/2011	Ishii		D757,732 S	5/2016	Galanti	
8,025,325 B1	9/2011	Carrier et al.		D758,284 S *	6/2016	Ringer	D12/415
8,028,777 B2	10/2011	Kakinuma		D762,179 S *	7/2016	Wong	D13/168
8,050,820 B2	11/2011	Yanaka		D763,359 S *	8/2016	Kwong	D14/401
8,050,837 B2	11/2011	Yamada		D764,520 S	8/2016	Lee	
8,074,388 B2	12/2011	Trainer		D765,718 S	9/2016	Vinna	
8,091,672 B2	1/2012	Gutsch		D769,314 S	10/2016	Piroddi	
8,113,244 B2	2/2012	Kamen et al.		D770,514 S	11/2016	Bae	
8,151,912 B2	4/2012	Koide et al.		D772,255 S	11/2016	Engel	
8,155,828 B2	4/2012	Fuwa et al.		D772,924 S	11/2016	Begin	
8,160,794 B2	4/2012	Fuwa		D775,148 S	12/2016	Anzures	
8,162,089 B2	4/2012	Shaw		D778,312 S	2/2017	Goodwin	
8,170,780 B2	5/2012	Field		D786,278 S	5/2017	Motamedi	
8,170,781 B2	5/2012	Fuwa		D786,770 S *	5/2017	Smallhorn	D12/345
8,172,016 B2	5/2012	Goertzen et al.		D787,420 S *	5/2017	Smallhorn	D12/345
8,186,462 B2	5/2012	Kamen		9,662,438 B2	5/2017	Kamen et al.	
8,224,524 B2	7/2012	Nakashima		D792,444 S	7/2017	Cho	
8,225,891 B2	7/2012	Takenaka		D797,772 S	9/2017	Mizono	
8,248,222 B2	8/2012	Kamen		D798,318 S	9/2017	Ferguson	
8,249,773 B2	8/2012	Kawada		9,750,896 B2	9/2017	Kamen et al.	
8,255,105 B2	8/2012	Weissert		D801,996 S	11/2017	Yang	
8,265,774 B2	9/2012	Senba		D802,002 S	11/2017	Howard	
8,285,474 B2	10/2012	Doi		D804,393 S *	12/2017	Yoo	D12/415
8,312,017 B2	11/2012	Martin et al.		D805,972 S *	12/2017	Lee	D12/174
8,346,441 B2	1/2013	Miki		D805,973 S *	12/2017	Mullaney	D12/177
8,371,410 B2	2/2013	Fuwa		D807,235 S	1/2018	Collins	
D678,217 S *	3/2013	Helm	D13/162	D807,236 S	1/2018	Collins	
D678,320 S	3/2013	Kanalakis, Jr.		D807,277 S *	1/2018	Lee	D12/415
8,417,404 B2	4/2013	Yen		D812,533 S *	3/2018	Lee	D12/174
8,418,705 B2	4/2013	Ota et al.		D814,370 S *	4/2018	Kim	D12/174
8,453,768 B2	6/2013	Kamen		D825,437 S *	8/2018	Hilton	D12/415
8,467,941 B2	6/2013	Field		D825,493 S *	8/2018	Chen	D13/164
D686,200 S *	7/2013	Huang	D14/253	2002/0007239 A1	1/2002	Matsumoto	
8,490,723 B2	7/2013	Heinzmann		2002/0056582 A1	5/2002	Chubb	
8,504,248 B2	8/2013	Taira		2002/0063006 A1	5/2002	Kamen	
8,564,444 B2	10/2013	Ota et al.		2002/0082749 A1	6/2002	Meyers	
8,584,782 B2	11/2013	Chen		2002/0121394 A1	9/2002	Kamen	
8,621,684 B2	1/2014	Okumatsu		2002/0121572 A1	9/2002	Jacobson	
8,636,451 B2	1/2014	Yamashita et al.		2002/0189870 A1	12/2002	Kamen	
8,639,416 B2	1/2014	Jones		2003/0014167 A1	1/2003	Pedersen	
8,640,807 B2	2/2014	Takenaka		2003/0128840 A1	7/2003	Luginbill	
8,672,339 B2	3/2014	Raike, III		2003/0226698 A1	12/2003	Kamen	
8,672,356 B2	3/2014	Inaguma		2004/0005958 A1	1/2004	Kamen	
8,684,123 B2	4/2014	Chen		2004/0007399 A1	1/2004	Heinzmann	

US D846,452 S

2004/0007644	A1	1/2004	Phelps, III et al.	2017/0176188	A1	6/2017	Georgy	
2004/0055796	A1	1/2004	Kamen	2017/0240169	A1	8/2017	Coulter et al.	
2004/0069543	A1	4/2004	Kamen	2017/0259811	A1	9/2017	Coulter et al.	
2004/0124655	A1	7/2004	Takenoshita et al.	2017/0300058	A1	10/2017	Peret et al.	
2004/0135434	A1	7/2004	Honda	2018/0056985	A1	3/2018	Coulter et al.	
2004/0201271	A1	10/2004	Kakinuma	2018/0102227	A1	4/2018	Poon	
2004/0256886	A1	12/2004	Wu	2018/0164829	A1*	6/2018	Oshima	A61G 5/043
2004/0262871	A1	12/2004	Schreuder	2018/0203522	A1*	7/2018	Stucki	A61G 5/045
2005/0029023	A1	2/2005	Takami					
2005/0121866	A1	6/2005	Kamen					
2005/0134014	A1	6/2005	Xie					
2005/0211477	A1	9/2005	Gray					
2005/0236208	A1	10/2005	Runkles					
2005/0236894	A1	10/2005	Lu					
2006/0108956	A1	5/2006	Clark					
2006/0163437	A1	7/2006	Lin					
2006/0202439	A1	9/2006	Kahlert					
2006/0231313	A1	10/2006	Ishii					
2006/0279554	A1	12/2006	Shin					
2007/0001830	A1	1/2007	Dagci					
2007/0100511	A1	5/2007	Koerlin					
2007/0213900	A1	9/2007	Raab					
2007/0221423	A1	9/2007	Chang					
2007/0296170	A1	12/2007	Field					
2008/0029985	A1	2/2008	Chen					
2008/0147281	A1	6/2008	Ishii					
2008/0149798	A1	6/2008	Tinoco					
2008/0174415	A1	7/2008	Tanida					
2008/0197599	A1	8/2008	Comstock					
2008/0238005	A1	10/2008	James					
2008/0302938	A1	12/2008	Goodwin					
2009/0009984	A1	1/2009	Mangiardi					
2009/0032323	A1	2/2009	Kakinuma					
2009/0078485	A1	3/2009	Gutsch					
2009/0105908	A1	4/2009	Casey					
2009/0115149	A1	5/2009	Wallis					
2009/0224524	A1	9/2009	Rathsack					
2010/0025139	A1	2/2010	Kosaka					
2010/0107076	A1	4/2010	Grohman					
2010/0114468	A1	5/2010	Field					
2010/0121538	A1	5/2010	Ishii					
2010/0126787	A1	5/2010	Kawada					
2010/0222994	A1	9/2010	Field					
2010/0230919	A1	9/2010	Kawada					
2010/0235028	A1	9/2010	Ishii					
2010/0237645	A1	9/2010	Trainer					
2010/0250040	A1	9/2010	Yamano					
2011/0035101	A1	2/2011	Kawada et al.					
2011/0209929	A1	9/2011	Heinzmann					
2011/0215540	A1	9/2011	Hunziker et al.					
2011/0220427	A1	9/2011	Chen					
2011/0221160	A1	9/2011	Shaw					
2011/0238247	A1	9/2011	Yen					
2011/0285195	A1	11/2011	Ratgen					
2012/0197470	A1	8/2012	Inui					
2012/0205176	A1	8/2012	Ha					
2012/0219395	A1	8/2012	Inaguma et al.					
2012/0239284	A1	9/2012	Field					
2012/0290162	A1	11/2012	Stevens					
2013/0032422	A1	2/2013	Chen					
2013/0032423	A1	2/2013	Chen					
2013/0105239	A1	5/2013	Fung					
2013/0228385	A1	9/2013	Chen					
2013/0253769	A1	9/2013	Kamo					
2014/0018994	A1	1/2014	Panzarella					
2014/0058600	A1	2/2014	Hoffmann					
2014/0083225	A1	3/2014	Downs					
2014/0277888	A1	9/2014	Dastoor					
2015/0060162	A1	3/2015	Goffer					
2015/0112264	A1	4/2015	Kamen et al.					
2015/0123453	A1	5/2015	Benoit, Jr.					
2015/0198440	A1	7/2015	Pearlman					
2015/0231891	A1	8/2015	Yashiro et al.					
2015/0245962	A1	9/2015	Furuta					
2015/0246703	A1	9/2015	Oishi et al.					
2015/0289653	A1	10/2015	Hector et al.					
2016/0014252	A1	1/2016	Biderman et al.					
2016/0035161	A1	2/2016	Friedli et al.					
2016/0264019	A1	9/2016	Drako					

FOREIGN PATENT DOCUMENTS

CA	2580632	3/2006
CA	2822729	3/2006
CA	2897221	3/2006
CN	101056680	10/2007
CN	104071275	10/2014
DE	2048593	5/1971
DE	3103961	9/1982
DE	3128112	2/1983
DE	3242880	6/1983
DE	3411489	10/1984
DE	4110905	10/1991
DE	4404594	8/1995
DE	19625498	11/1997
DE	29808091	8/1998
DE	29808096	8/1998
DE	10209093	9/2003
EP	0109927	5/1984
EP	0193473	9/1986
EP	0537698	4/1993
EP	0551986	7/1993
EP	0663313	7/1995
EP	0746089	12/1996
EP	0958978	11/1999
EP	1063530	12/2000
EP	1759973	3/2007
EP	1805071	7/2007
FR	980237	5/1951
FR	2502090	9/1982
GB	152664	1/1922
GB	1213930	11/1970
GB	2139576	11/1984
GB	2388579	11/2003
JP	52-44933	4/1977
JP	57-87766	1/1982
JP	57-110569	7/1982
JP	59-73372	4/1984
JP	60-255580	12/1985
JP	62-12810	1/1987
JP	63-305082	12/1988
JP	H01-316810	12/1989
JP	2-190277	7/1990
JP	4-201793	7/1992
JP	5-213240	8/1993
JP	6-171562	12/1994
JP	61-05415	12/1994
JP	7255780	10/1995
JP	9-248320	9/1997
JP	10-023613	1/1998
JP	2000-070308	7/2000
JP	2000-288032	10/2000
JP	2005-022631	1/2005
JP	4572594	1/2006
JP	2007-069688	3/2007
JP	D1314974	11/2007
JP	D1323922	3/2008
JP	4687784	7/2010
JP	2010-240011	10/2010
JP	2010-274759	12/2010
JP	2011-246124	12/2011
JP	5243795	7/2013
JP	2014-019212	2/2014
JP	2014-174275	9/2014
JP	2014-195403	10/2014
JP	2014-218247	11/2014
JP	2015-070897	4/2015
JP	2015-171895	10/2015
JP	2016-084135	5/2016
JP	2018-062344	4/2018

TW	D124942	6/2006
TW	D124943	6/2006
WO	WO 1986/05752	10/1986
WO	WO 1989/06117	7/1989
WO	WO 1996/23478	8/1996
WO	WO 1998/46474	10/1998
WO	WO 1999/11488	3/1999
WO	WO 2000/023315	4/2000
WO	WO2000023315	4/2000
WO	WO 2000/054719	9/2000
WO	WO/2000/054721	9/2000
WO	WO2000054719	9/2000
WO	WO 2000/075001	12/2000
WO	WO 2001/002920	1/2001
WO	WO/2002/030730	4/2002
WO	WO 2002/072383	9/2002
WO	WO/2002/072383	9/2002
WO	WO/2003/103559	12/2003
WO	WO 2004/007264	1/2004
WO	WO/2004/078603	9/2004
WO	WO 2006/031917	3/2006
WO	WO 2006/042302	4/2006
WO	WO 2009/052471	4/2009
WO	WO2001002920	1/2010
WO	WO 2010/084421	7/2010
WO	WO/2012/090248	7/2012
WO	WO/2013/096789	6/2013
WO	WO/2003/106250	12/2013
WO	WO 2015/167411	11/2015
WO	WO 2017/147347	8/2017
WO	WO2017147347	8/2017
WO	WO 2017/180868	10/2017
WO	WO2017180868	10/2017
WO	WO 2017/201513	11/2017
WO	WO2017201513	11/2017

OTHER PUBLICATIONS

D-r-net_CJSM2-400x280. magicmobility.com.au. [online img] 1 pg. Uploaded Nov. 2013. [Retrieved on Aug. 15, 2018] https://www.magicmobility.com.au/wp-content/uploads/2013/11/D-r-net_CJSM2-400x280.jpg.*

Introducing electric wheelchair without stairs Scewo. blog.naver.com. [online] 2 pgs. Posted Mar. 19, 2017. [Retrieved on Aug. 8, 2018] <http://blog.naver.com/PostView.nhn?blogId=hwh7588&logNo=220987227590&categoryNo=0&parentCategoryNo=0&viewDate=¤tPage=1&postListTopCurrentPage=1&from=postView>.*

Controllers. (Design—© Questel) orbit.com.[online PDF] 9 pgs. Print Dates range Oct. 16, 2013 to Mar. 5, 2015. [Retrieved on Aug. 15, 2018] <https://sobjprd.questel.fr/export/QPTUJ214/pdf2/ded442a0-b76c-4173-9dae-7cbb93247074-235637.pdf>.*

Adhikari, B., A Single Subject Participatory Action Design Method for Powered Wheelchairs Providing Automated Back-in Parking Assistance to Cognitively Impaired Older Adults: A pilot study, Department of Computer Science, The University of British Columbia, Vancouver, Canada, Jan. 5, 2015, slide deck.

Adhikari, B., A Single Subject Participatory Action Design Method for Powered Wheelchairs Providing Automated Back-in Parking Assistance to Cognitively Impaired Older Adults: A pilot study, Master's Thesis, Department of Computer Science, The University of British Columbia, Vancouver, Canada, Dec. 2014.

Brown, Jr. et al., "A Single-Wheel Gyroscopically Stabilized Robot," IEEE Robotics & Automation Magazine, Sep. 1997.

Cooper, Rory A., Intelligent Control of Power Wheelchairs, IEEE Engineering in Medicine and Biology Magazine, IEEE Service Center, Piscataway, NJ, US, vol. 14, No. 4, Jul. 1, 1995, pp. 423-431, XP11084628.

Dejun Yin and Yoichi Hori, "A Novel Traction Control for Electric Vehicle without Chassis Velocity, Motion Control", Federico Casolo (Ed.), InTech, DOI: 10.5772/6962. Available from: <https://mts.intechopen.com/books/motion-control/a-novel-traction-control-for-electric-vehicle-without-chassis-velocity>, 2010.

Elnagar, A., "Prediction of Moving Objects in Dynamic Environments Using Kalman Filters," Proceedings of 2001 IEEE Interna-

tional Symposium on Computational Intelligence in Robotics and Automation, Jul. 29-Aug. 1, 2001.

Fresk, et al., Full Quaternion Based Attitude Control for a Quadrotor, 2013 European Control Conference (EDD), Jul. 17-19, 2013, Zurich, Switzerland, pp. 3864-3869.

Grasser, F. et al., "JOE: A Mobile, Inverted Pendulum," IEEE Transactions on Industrial Electronics, vol. 49, No. 1, Feb. 2002.

Ha, et al. "Trajectory Tracking Control for Navigation of Self-Contained Mobile Inverse Pendulum" Intelligent Robots and Systems '94. 'Advanced Robotic Systems and the Real World', IROS '94. Proceedings of the IEEE/RSJ/GI International Conference on, vol. 3, No., pp. 1875-1882, Sep. 12-16, 1994.

Ha, et al., "Trajectory Tracking Control for Navigation of the Inverse Pendulum Type Self-Contained Mobile Robot" 17 Robotics and Autonomous Systems 60-85 (1996).

Helgesson, L., "Pitch and roll estimating kalman filter for stabilizing quadcopters", <http://lhelge.se/2012/04/pitch-and-roll-estimating-kalman-filter-for-stabilizing-quadcopters/>, Oct. 15, 2012.

How et al., "Clinical Evaluation of the Intelligent Wheelchair System", Proceedings of Festival of international Conference on Caregiving, Disability, Aging and Technology, Toronto, Canada, 2011.

I-Real, Personal Mobility Device, <https://www.youtube.com/watch?v=WAGpxIUdWw>, Published on Jan. 15, 2013, appeared first in Apr. 2012, D1 Grand Prix event, Odaiba, JP.

Ishida and Miyamoto, "Collision-Detecting Device for Omnidirectional Electric Wheelchair", Research Article, ISRN Robotics, vol. 2013, Article ID 672826, Nov. 1, 2012.

I-swing, Single Person Vehicle, https://www.youtube.com/watch?feature=player_embedded&v=1QSybf7sLtg, Published on Sep. 14, 2006, Featured on Hacked Gadgets, <http://hackedgadgets.com>.

I-Unit, Wheelchair, <https://www.youtube.com/watch?v=Rbrrlrh3GBE>, Published on Jun. 6, 2006, Filmed at Megaweb Center at Tokyo.

Johnson, R.C., "Unicycles and bifurcations", American J. of Physics, vol. 66, No. 7, 589-92 (Oct. 22, 2002).

Kanoh, "Applied Control of Inverted Pendulum", Computrol, vol. 2, (1983), pp. 69-75.

Kawaji, S., Stabilization of Unicycle Using Spinning Motion, Denki Gakkai Ronbunshi, D, vol. 107, Issue 1, Japan (1987), pp. 21-28.

Koyanagi et al., A Wheeled Inverse Pendulum Type Self-Contained Mobile Robot, The Society of Instrument and Control Engineers, Special issue of the 31st SICE Annual Conference, Japan 1992, pp. 51-56.

Koyanagi et al., A Wheeled Inverse Pendulum Type Self-Contained Mobile Robot and its Two Dimensional Trajectory Control, Proceeding of the Second International Symposium on Measurement and Control in Robotics, Japan 1992, pp. 891-898.

Koyanagi et al., A Wheeled Inverse Pendulum Type Self-Contained Mobile Robot and its Posture Control and Vehicle Control, The Society of Instrument and Control Engineers, Special issue of the 31st SICE Annual Conference, Japan, 1992, pp. 13-16.

Lam, H. K. et al., "Fuzzy Model Reference Control of Wheeled Mobile Robots," The 27th Annual Conference of the IEEE Industrial Electronics Society (2001).

Liu, H.S. et al., "Accelerometer for Mobile Robot Positioning," IEEE Transactions on Industry Applications, vol. No. 3, Oct. 1999.

Momoi & Yamafuji, Motion Control of the Parallel Bicycle-Type Mobile Robot Composed of a Triple Inverted Pendulum, Paper Read at Meeting of Japan Society of Mechanical Engineering (Series C), vol. 57, No. 541, (Sep. 1991), pp. 154-159.

Montella, C., et al., To the Bookstore! Autonomous Wheelchair Navigation in an Urban Environment, Lehigh University, published in FSR, 2012, Part of the Springer Tracts in Advanced Robotics book series (STAR, vol. 92), first online Dec. 31, 2013.

Oishi et al., Building a Smart Wheelchair on a Flexible Software Platform, RESNA International Conference on Technology and Aging, 2011.

Osaka et al., Stabilization of unicycle, Systems and Control, vol. 25, No. 3, Japan Mar. 1981, pp. 159-166.

PCT/US2017/019214, Written Opinion of the International Search Authority, dated Aug. 31, 2017.

- PCT/US2017/027410, Written Opinion of the International Search Authority, dated Dec. 4, 2017.
- PCT/US2017/033705, Written Opinion of the International Search Authority, dated Nov. 23, 2017.
- Roy et al., Five-Wheel Unicycle System, Medical & Biological Engineering & Computing, vol. 23, No. 6, United Kingdom Nov. 1985, pp. 593-596.
- Sabatini, A., "Quaternion-based Extended Kalman Filter for Determining Orientation by Inertial and Magnetic Sensing", IEEE Transactions on Biomedical Engineering, vol. 53:7, Jul. 2006, pp. 1346-1356.
- Schoonwinkel, A. Design and Test of a Computer-Stabilized Unicycle, Stanford University (1988), UMI Dissertation Services, Dissertation Abstracts International, vol. 49/03-B, Stanford University 1987, pp. 890-1294.
- Sheng et al., "Postural Stability of a Human Riding a Unicycle and Its Emulation by a Robot," IEEE Transactions on Robotics and Automation, vol. 13:5, Oct. 1997.
- Sheng, Zaiquan; Yamafuji, Kazuo: Realization of a Human Riding a Unicycle by a Robot. Proceedings of the 1995 IEEE International Conference on Robotics and Automation, vol. 2., 1995, pp. 1319-1326.
- Stew's Hovercraft Page, <http://www.stewcam.com/hover-craft.html>.
- Takahashi et al., "Back and Forward Moving Scheme of Front Wheel Raising for Inverse Pendulum Control Wheel Chair Robot", Proceedings of the 2001 IEEE International Conference on Robotics & Automation, Seoul, Korea, May 21-26, 2001, pp. 3189-3194.
- Takahashi et al., "Front Wheel Raising and Inverse Pendulum Control of Power Assist Wheel Chair Robot", IEEE, 1999, pp. 668-673.
- Tanaka et al., "A Mobile Robot for Service Use: Behaviour Simulation System and Intelligent Control," Proceedings of the 1997 IEEE/RSJ International Conference on Intelligent Robots and Systems, 1997.
- Technico'S Home Page, Those Amazing Flying Machines, <http://www.swiftsite.com/technico>, May 24, 1999.
- Ulyanov et al., "Fuzzy Intelligent Emotion and Instinct Control of a Robotic Unicycle," Proceedings of the 1996 4th International Workshop on Advanced Motion Control, Mar. 18-21, 1996.
- Ulyanov et al., Soft computing for the intelligent robust control of a robotic unicycle with a new physical measure for mechanical controllability. Soft Computing vol. 2:2, Jun. 1998, pp. 73-88.
- Viswanathan et al., "Navigation Assistance for Intelligent Wheelchairs", 3rd International Conference on Technology and Aging/RESNA, Toronto, 2011.
- Vos et al., Dynamics and Nonlinear Adaptive Control of an Autonomous Unicycle—Theory and Experiment, American Institute of Aeronautics and Astronautics, A90-26772 10-39, Washington, D.C. 1990, Abstract only.
- Vos, D., Dynamics and Nonlinear Adaptive Control of an Autonomous Unicycle, Massachusetts Institute of Technology, Jun. 7, 1989.
- Vos, D., Nonlinear Control of an Autonomous Unicycle Robot: Practical Issues, Massachusetts Institute of Technology, Jun. 5, 1992.
- Wang et al., "Real-time Model-based Electrical Powered Wheelchair Control", Med Eng Phys. Dec. 2009, 31(10): 1244-1254.
- Watson Industries, Inc., "Vertical Reference Manual ADS-C132-1A", Apr. 20, 2015, pp. 3-4.
- Welch et al., "An Introduction to the Kalman Filter," SIGGRAPH 2001, Department of Computer Science University of North Carolina at Chapel Hill, <http://www.cs.unc.edu/~{welch.gb}>, 2001.
- WO 2000/073101, IPER of the International Search Authority, filing date Mar. 14, 2000.
- WO 2000/075001, IPER of the International Search Authority, filing date Jun. 1, 2000.
- WO2002/030730, IPER of the International Search Authority, filing date Oct. 11, 2001.
- WO 2017/147347 Written Opinion of the International Search Authority, Int. App. #PCT/US2017/019214, priority date Feb. 23, 2016.
- WO 2017/201513, Invitation to pay additional fees and partial search report, Int. App. #PCT/US2017/033705, Intl. filing date May 20, 2017.
- WO 2017/201513, Written Opinion of the International Searching Authority, Int. App. #PCT/US2017/033705, Intl. filing date May 20, 2017.
- Yamafuji & Kawamura, "Study of Postural and Driving Control of Coaxial Bicycle", Paper Read at Meeting of Japan Society of Mechanical Engineering (Series C), vol. 54, No. 501, (May, 1988), pp. 1114-1121, Abstract in English.
- Yamafuji et al., Synchronous Steering Control of a Parallel Bicycle, Paper Read at Meeting of Japan Society of Mechanical Engineering (Series C), vol. 55, No. 513, (May 1989), pp. 1229-1234.
- Yamafuji, A Proposal for Modular-Structured Mobile Robots for Work that Principally Involve a Vehicle with Two Parallel Wheels, Automation Technology, vol. 20, pp. 113-118 (1988).
- Yun et al., "Implementation and Experimental Results of a Quaternion-Based Kalman Filter for Human Body Motion Tracking", Proceedings of the 2005 IEEE International Conference on Robotics and Automation, Barcelona, Spain, Apr. 2005, pp. 317-322.
- Yun et al., "Design, Implementation and Experimental Results of a Quaternion-Based Kalman Filter for Human Body Motion Tracking", IEEE Transactions on Robotics, vol. 22, No. 6, Dec. 2006, pp. 1216-1227.
- Zenkov, DV, AM Bloch, and JE Marsden [2001] The Lyapunov-Malkin Theorem and Stabilization of the Unicycle with Rider. Systems and Control Letters, vol. 45, No. 4, Apr. 5, 2002, pp. 293-302(10).
- Zenkov, DV, AM Bloch, NE Leonard and JE Marsden, Matching and Stabilization of Low dimensional Nonholonomic Systems. Proc. CDC, 39, (2000), 1289-1295.

* cited by examiner

Primary Examiner — Marie D. Fast Horse
(74) Attorney, Agent, or Firm — Kathleen Chapman

(57)

CLAIM

The ornamental design for a display housing, as shown and described.

DESCRIPTION

FIG. 1 is a front, top, right side perspective view of the display housing, showing our new design;
FIG. 2 is a top plan view thereof;
FIG. 3 is a bottom plan view thereof;
FIG. 4 is a right side elevational view thereof;
FIG. 5 is a left side elevational view thereof;
FIG. 6 is a rear side elevational view thereof;
FIG. 7 is a front side elevational view thereof; and,
FIG. 8 is a front top, right perspective view of the display housing, shown in its environment.
The broken lines showing the four concentric circular features in FIG. 3 depict parts of the display housing that form no part of the claim; all other broken lines depict environmental structure that forms no part of the claimed design.

1 Claim, 8 Drawing Sheets

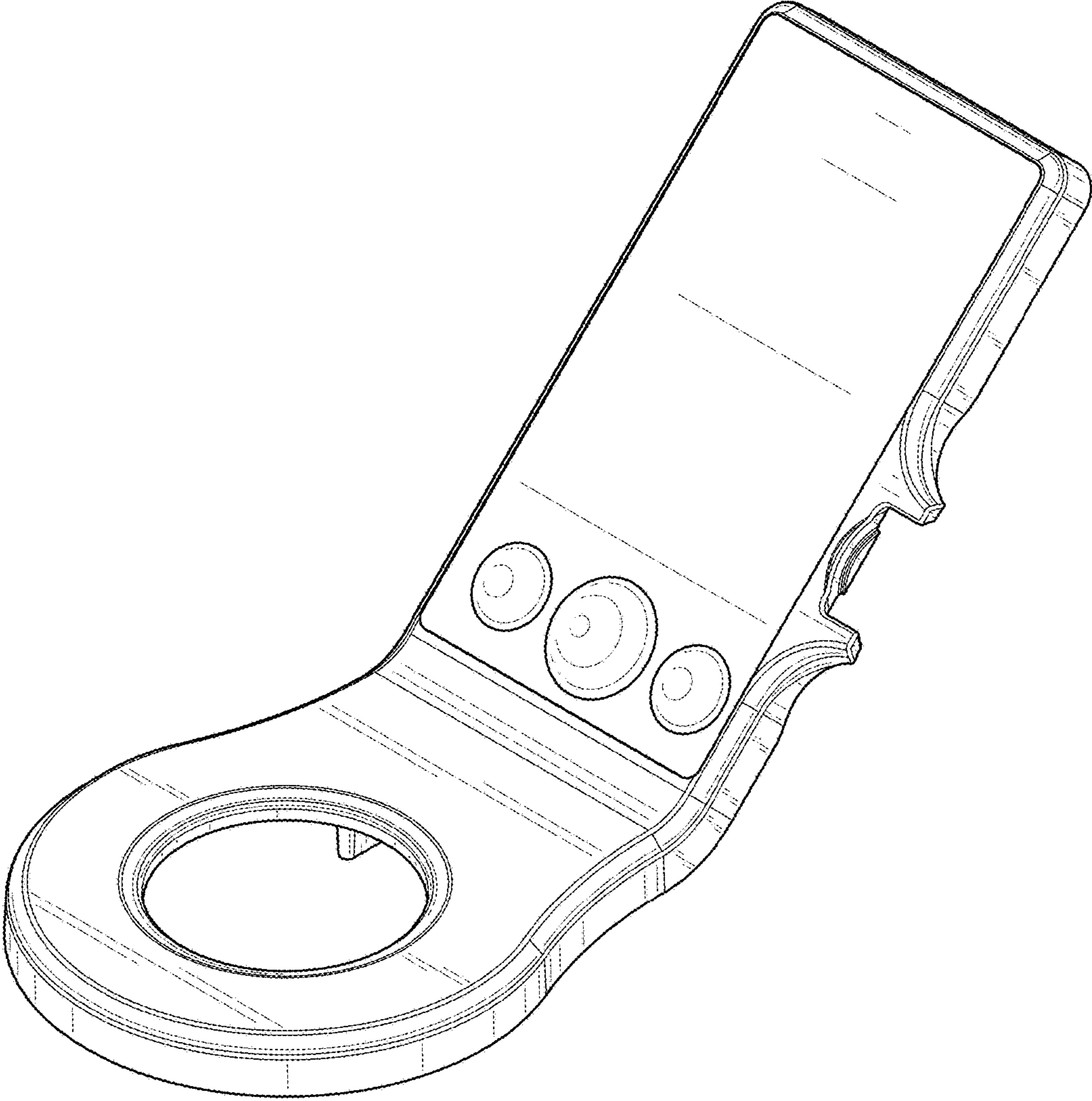

FIG. 1

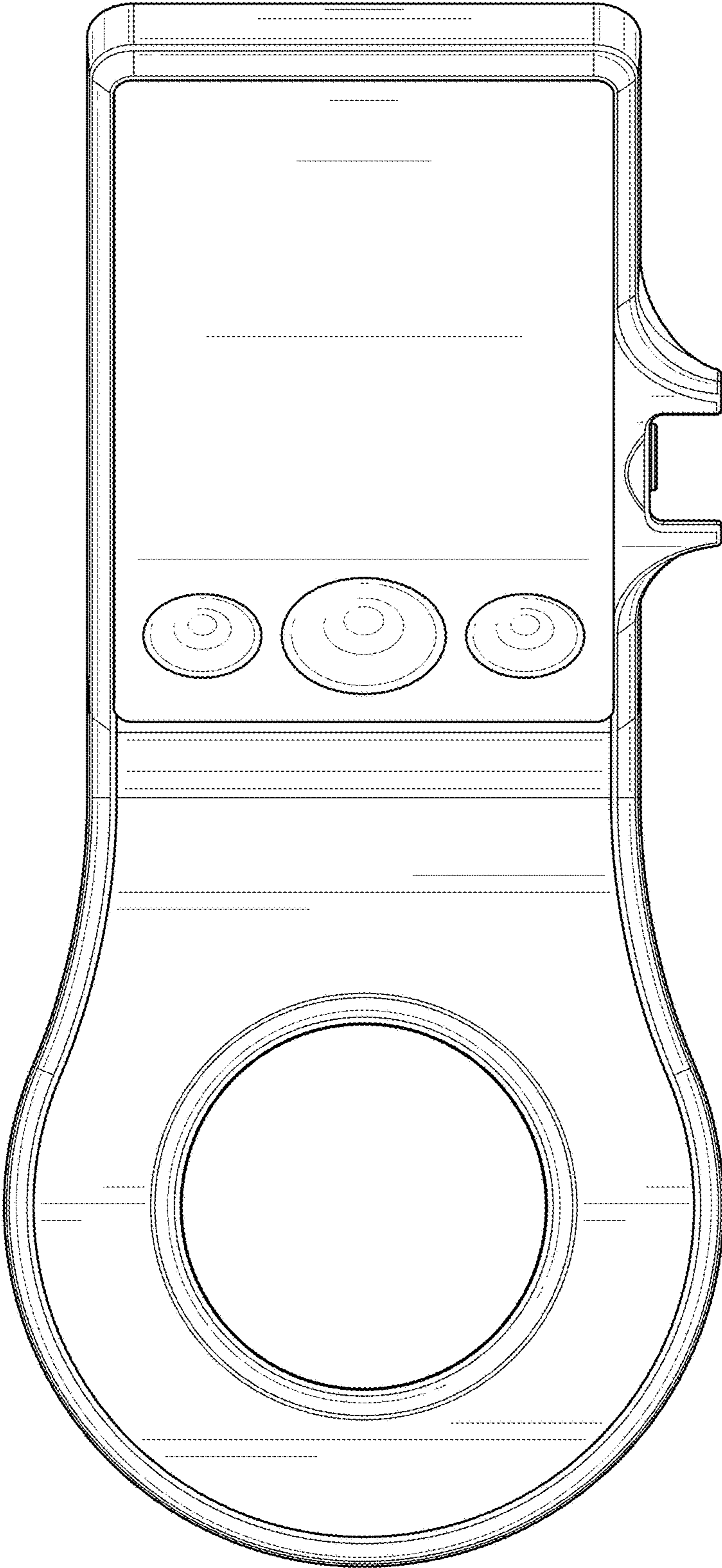

FIG. 2

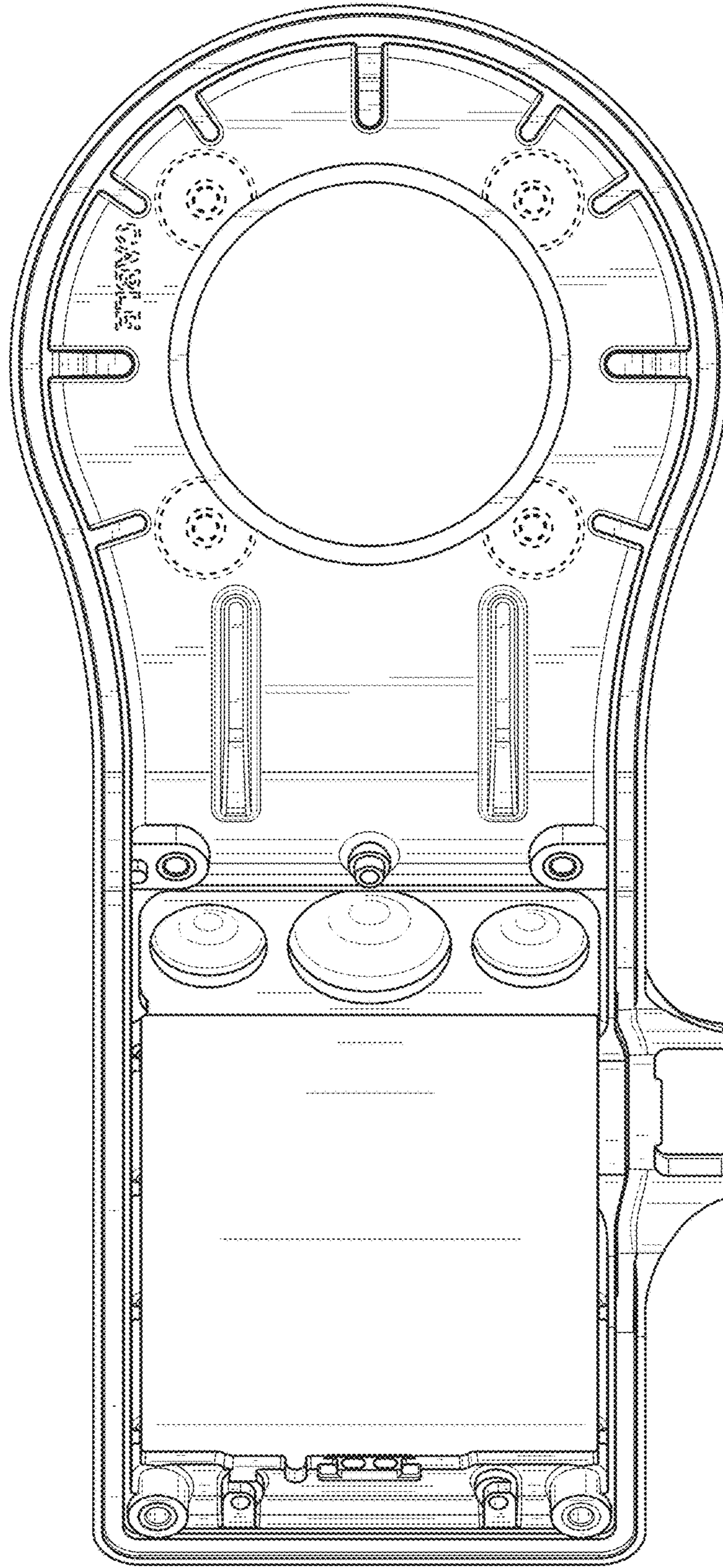

FIG. 3

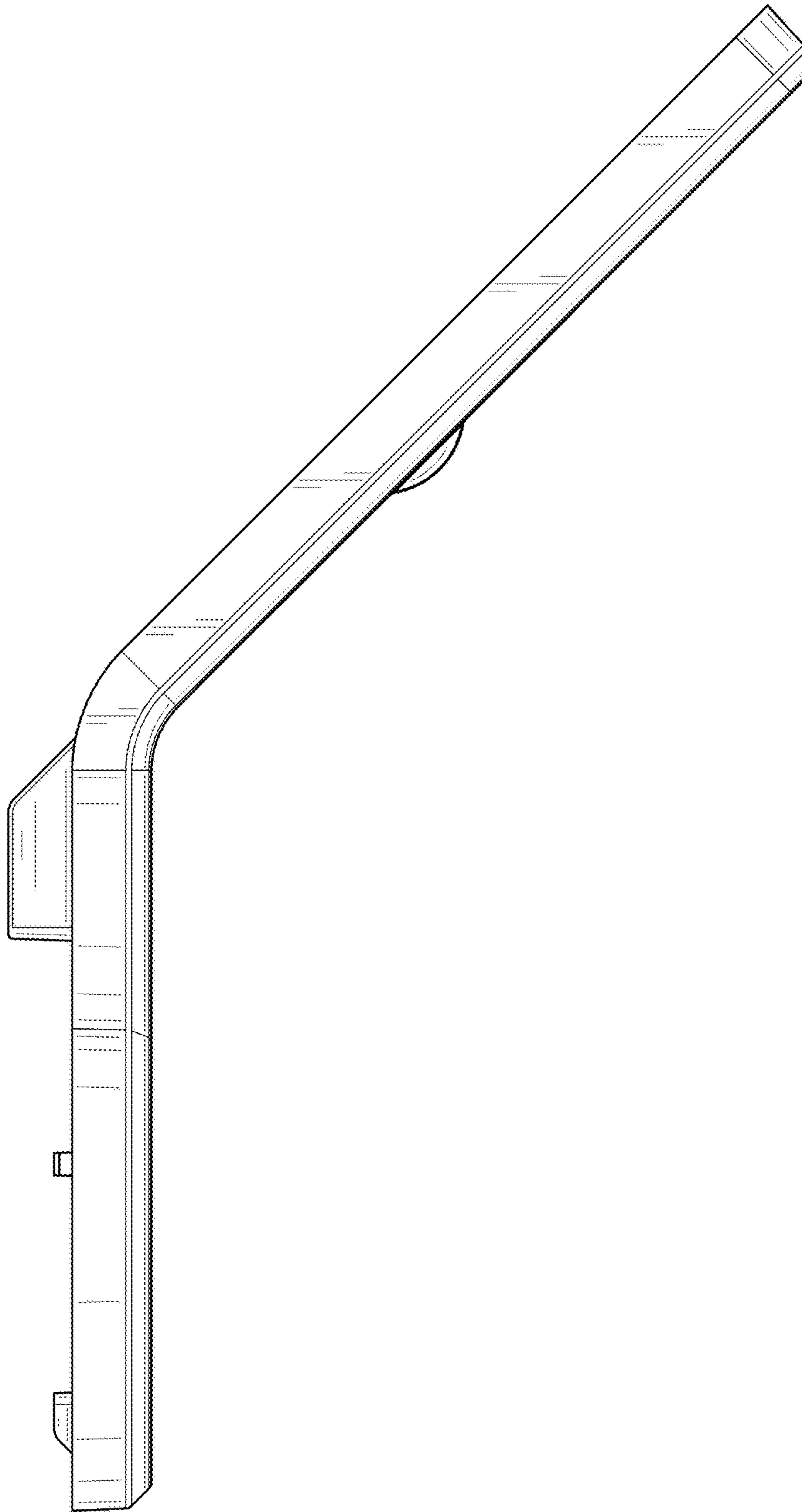

FIG. 4

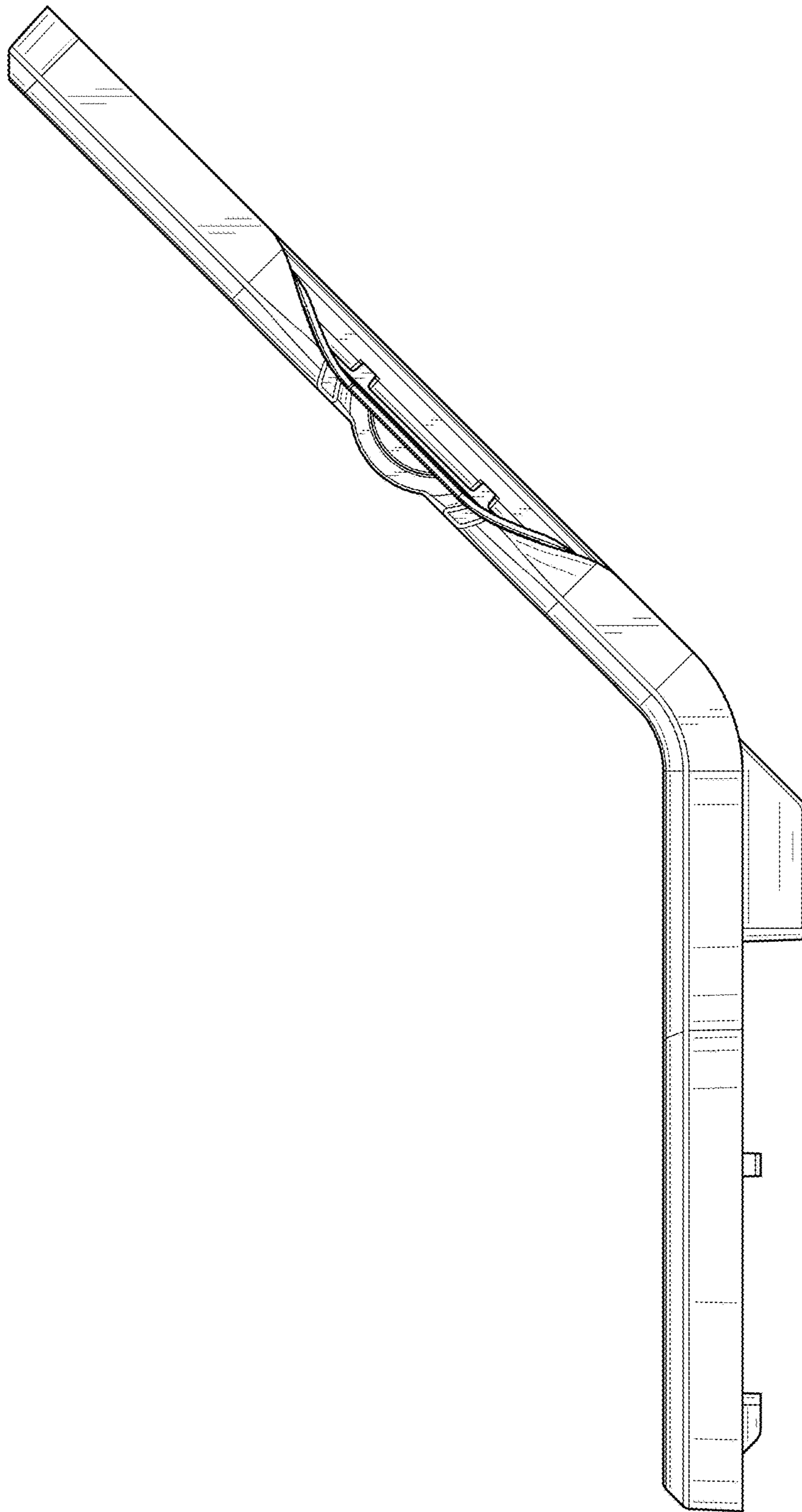

FIG. 5

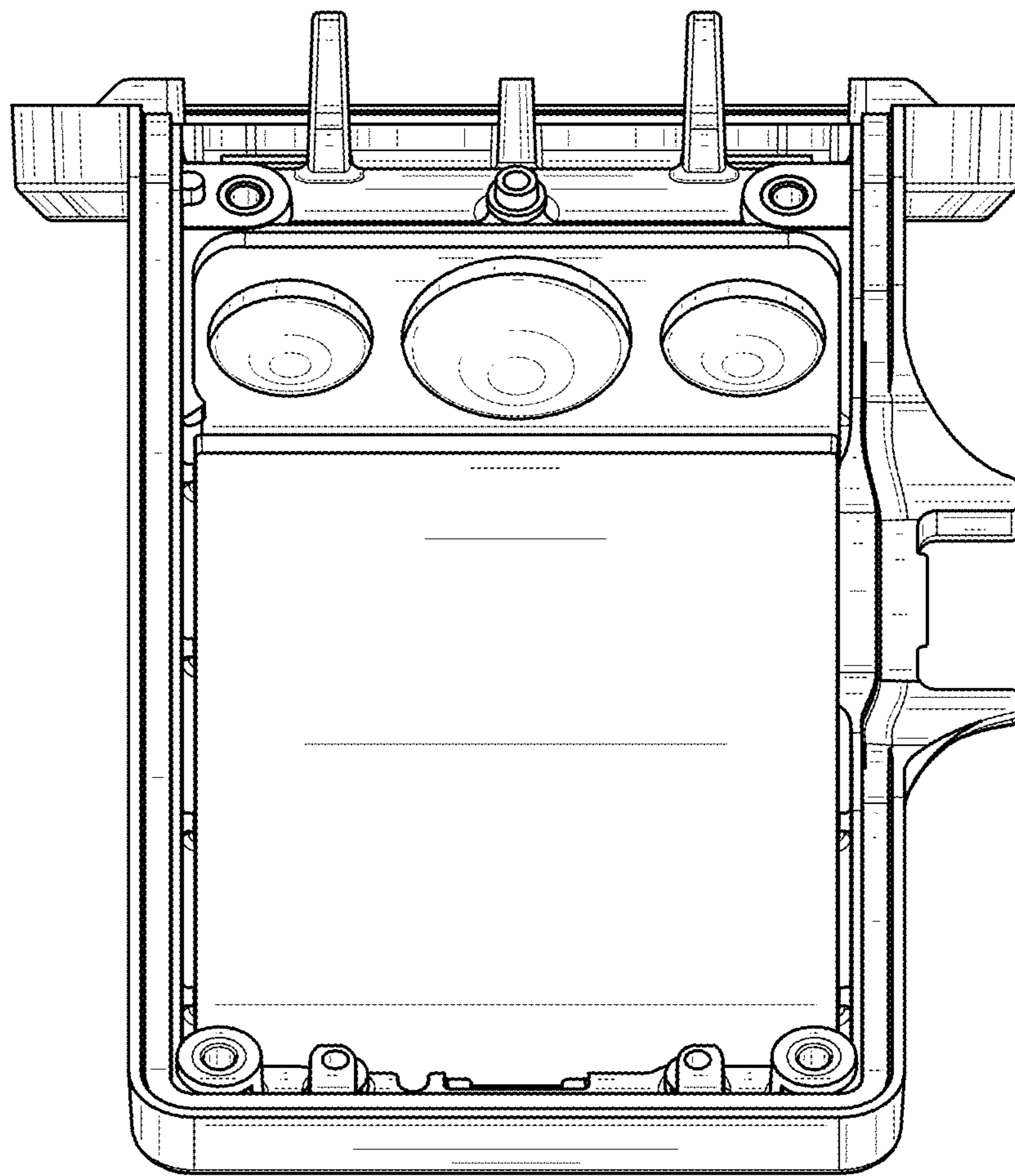

FIG. 6

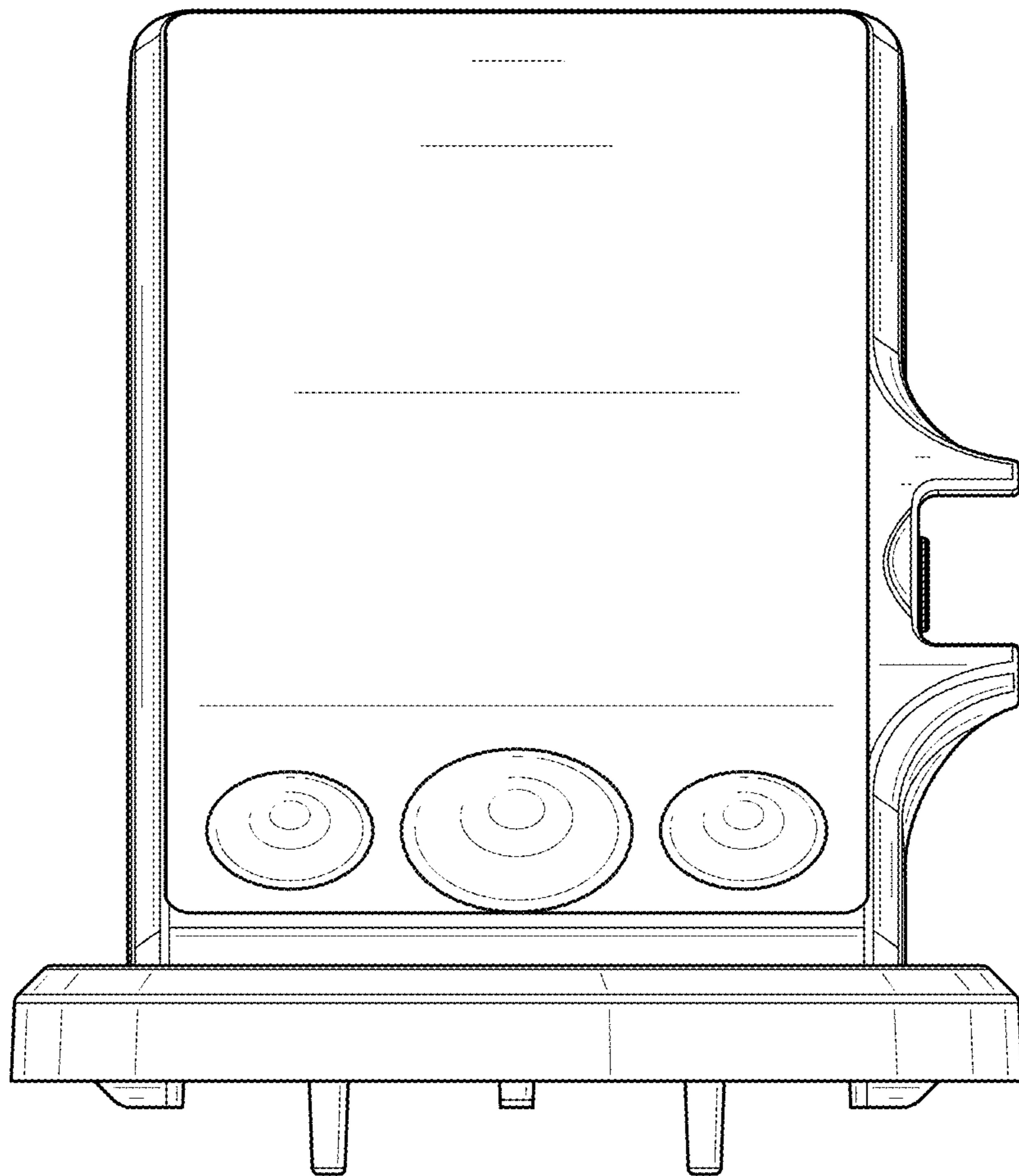

FIG. 7

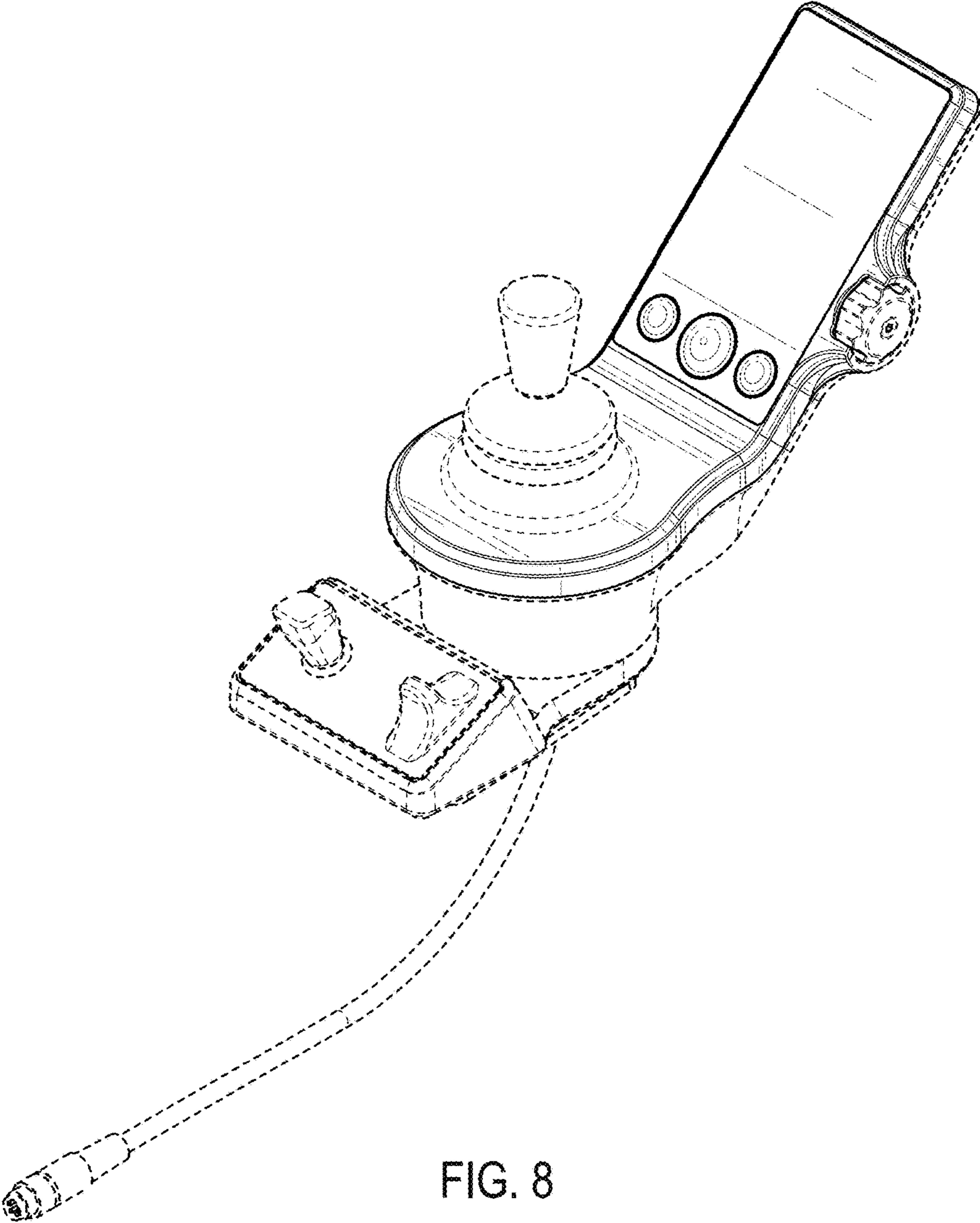

FIG. 8