



US00D846270S

(12) **United States Design Patent**  
**Tomasetta**

(10) **Patent No.:** **US D846,270 S**

(45) **Date of Patent:** **\*\* Apr. 23, 2019**

(54) **HANDBAG**

(71) Applicant: **Chloe S.A.S.**, Paris (FR)

(72) Inventor: **Marco Ettore Tomasetta**, Paris (FR)

(73) Assignee: **CHLOE S.A.S.**, Paris (FR)

(\*\*) Term: **15 Years**

(21) Appl. No.: **29/613,705**

(22) Filed: **Aug. 11, 2017**

(30) **Foreign Application Priority Data**

Mar. 1, 2017 (FR) ..... 20171080

Mar. 2, 2017 (EP) ..... 003781053

May 18, 2017 (FR) ..... 20172351

May 30, 2017 (EP) ..... 004024750

(51) **LOC (11) Cl.** ..... **03-01**

(52) **U.S. Cl.**

USPC ..... **D3/232**

(58) **Field of Classification Search**

USPC ..... D3/232-233, 240-243, 245-246

CPC ..... A45C 1/024; A45C 3/06

See application file for complete search history.

(56) **References Cited**

**U.S. PATENT DOCUMENTS**

D753,914 S \* 4/2016 Van Migem ..... D3/232

D781,051 S \* 3/2017 Leopardi ..... D3/232

\* cited by examiner

*Primary Examiner* — Holly H Baynham

(74) *Attorney, Agent, or Firm* — Fross Zelnick Lehrman & Zissu, P.C.; Charles T. J. Weigell, Esq.

(57) **CLAIM**

The ornamental design for a handbag, as shown and described.

**DESCRIPTION**

FIG. 1 is a front view of a handbag showing my new design, with handle shown in an upright position;

FIG. 2 is a front view thereof, with handle shown in a down position;

FIG. 3 is a front perspective view thereof;

FIG. 4 is a side view thereof (with the other side being a mirror image thereof);

FIG. 5 is a rear perspective view thereof;

FIG. 6 is a back view thereof;

FIG. 7 is a bottom view thereof; and,

FIG. 8 is a top view thereof.

The broken away symbols in the drawings indicate that any portion of the article beyond what is shown forms no part of the claimed design.

The broken lines depicting the shoulder straps, zippers, and zipper tabs show unclaimed subject matter for the design.

The dotted lines other than those depicting the shoulder straps, zippers, and zipper tabs are understood to represent stitching.

**1 Claim, 8 Drawing Sheets**

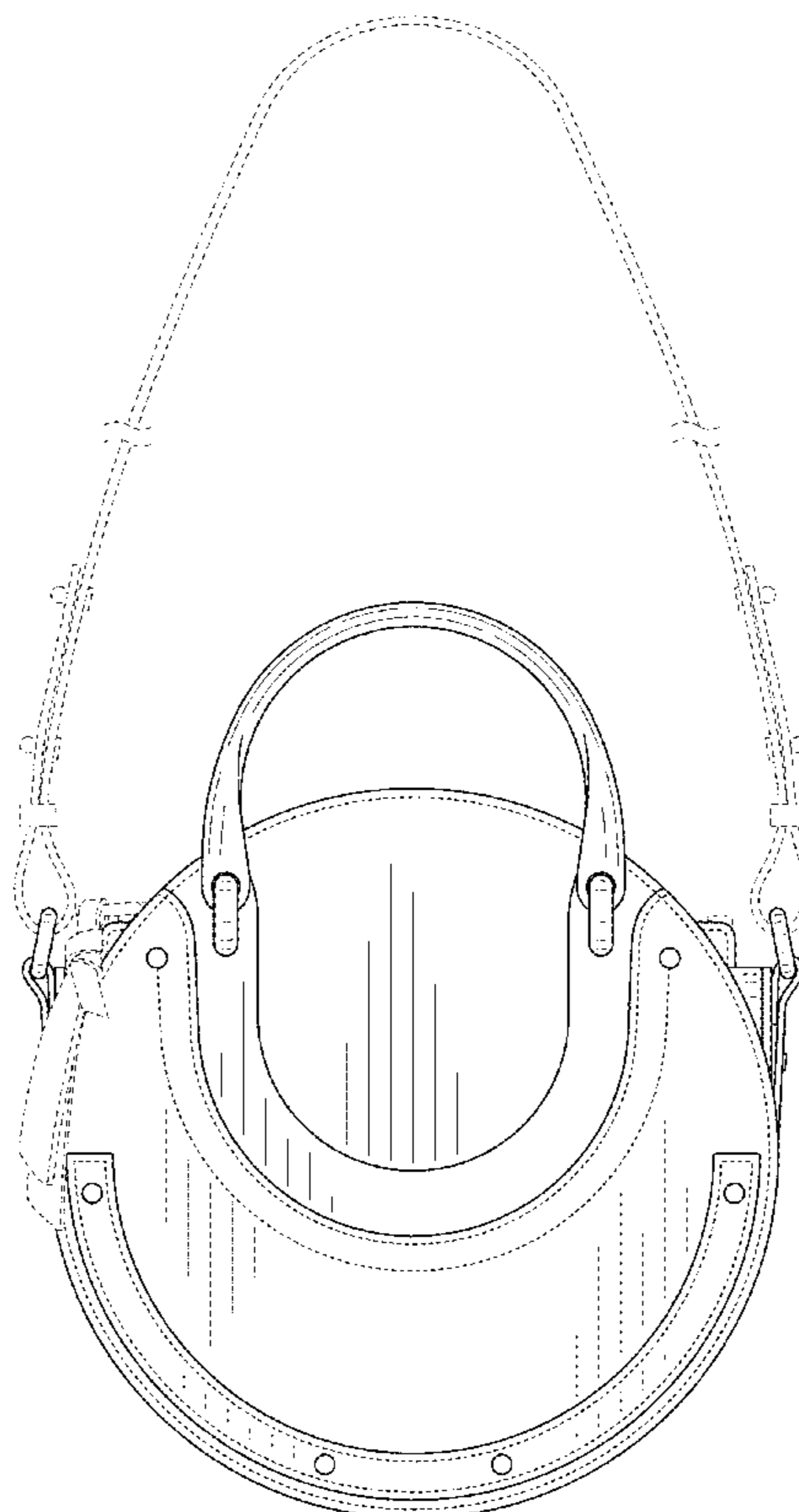

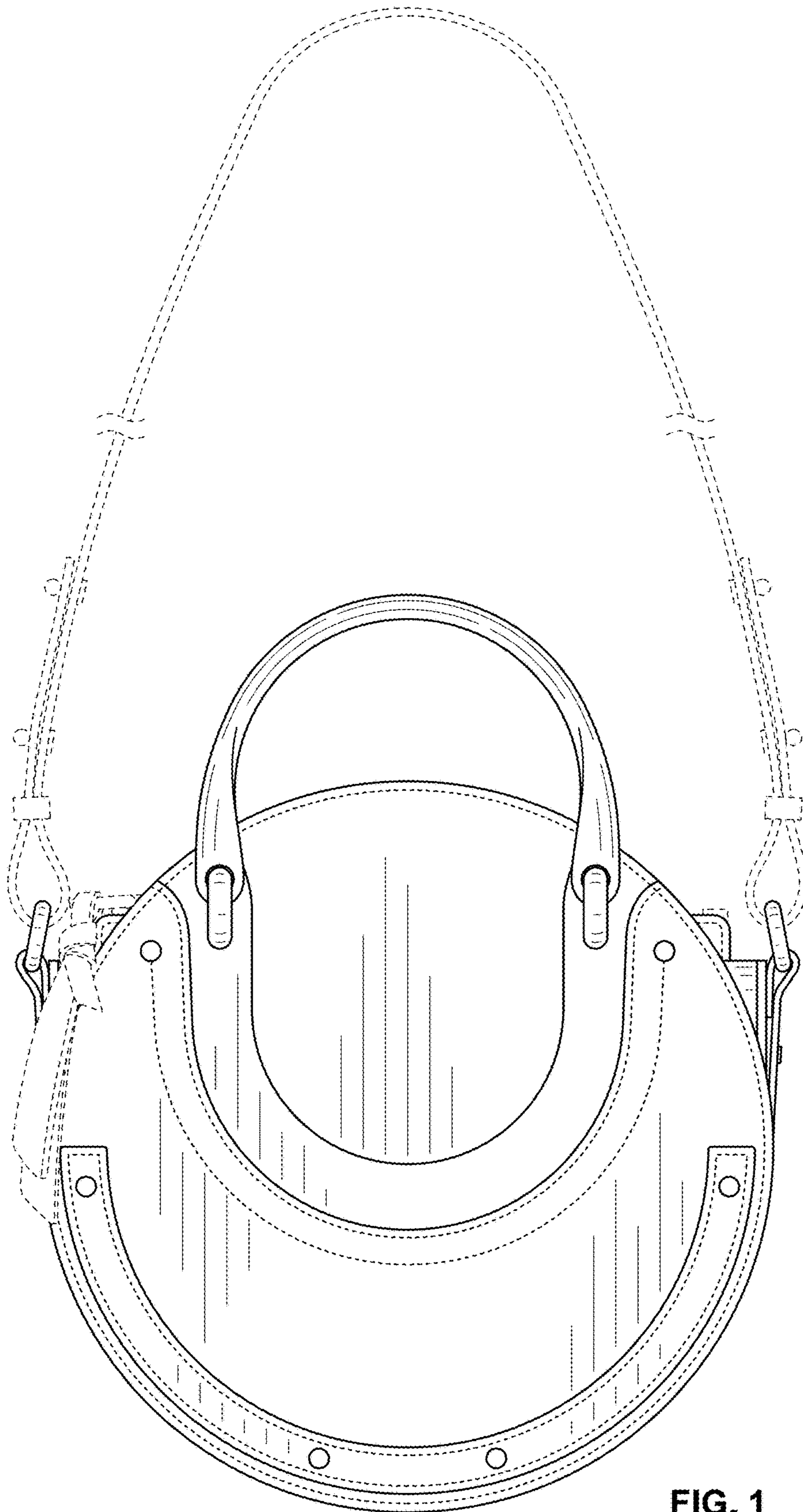

FIG. 1

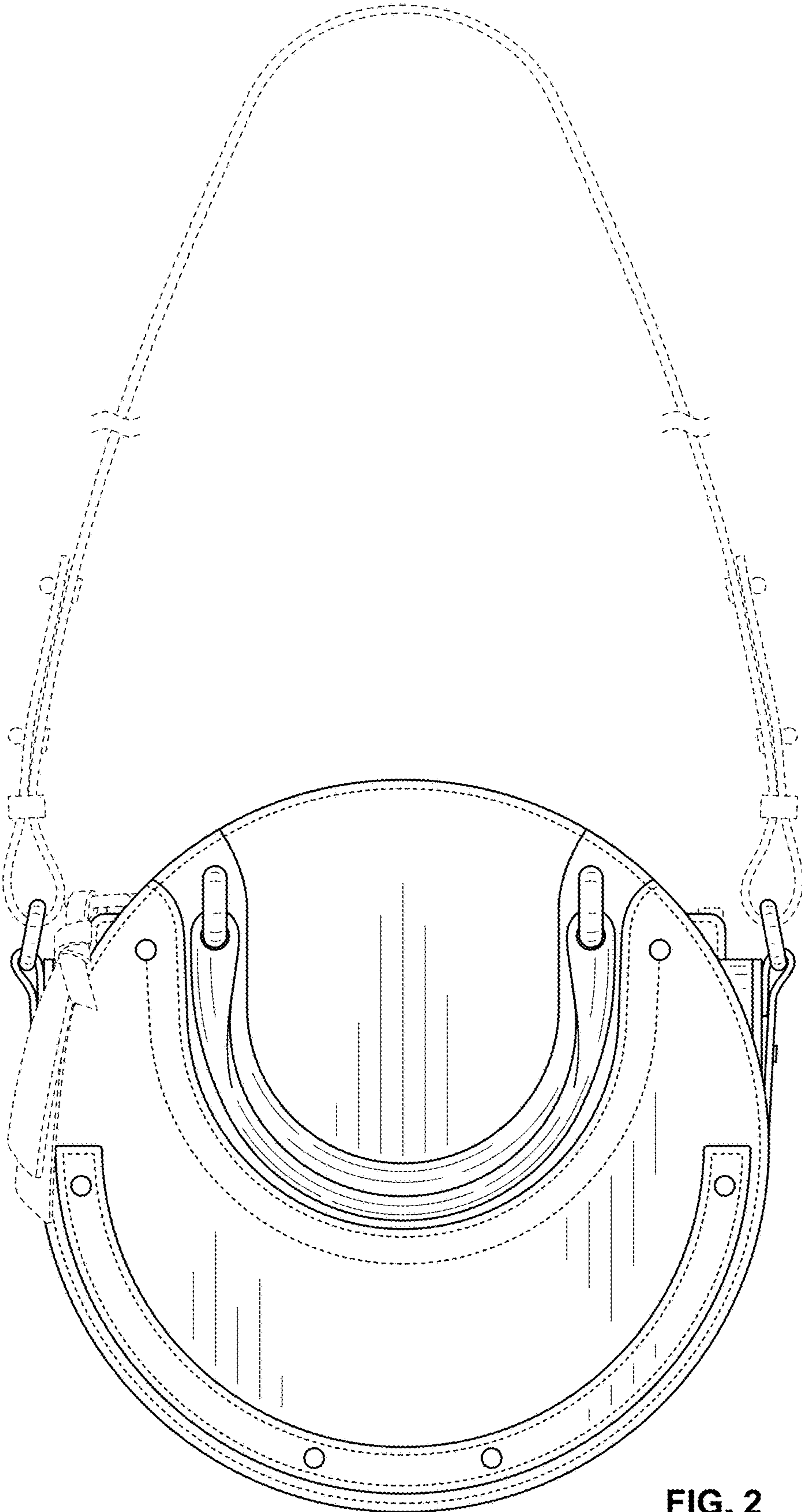

FIG. 2

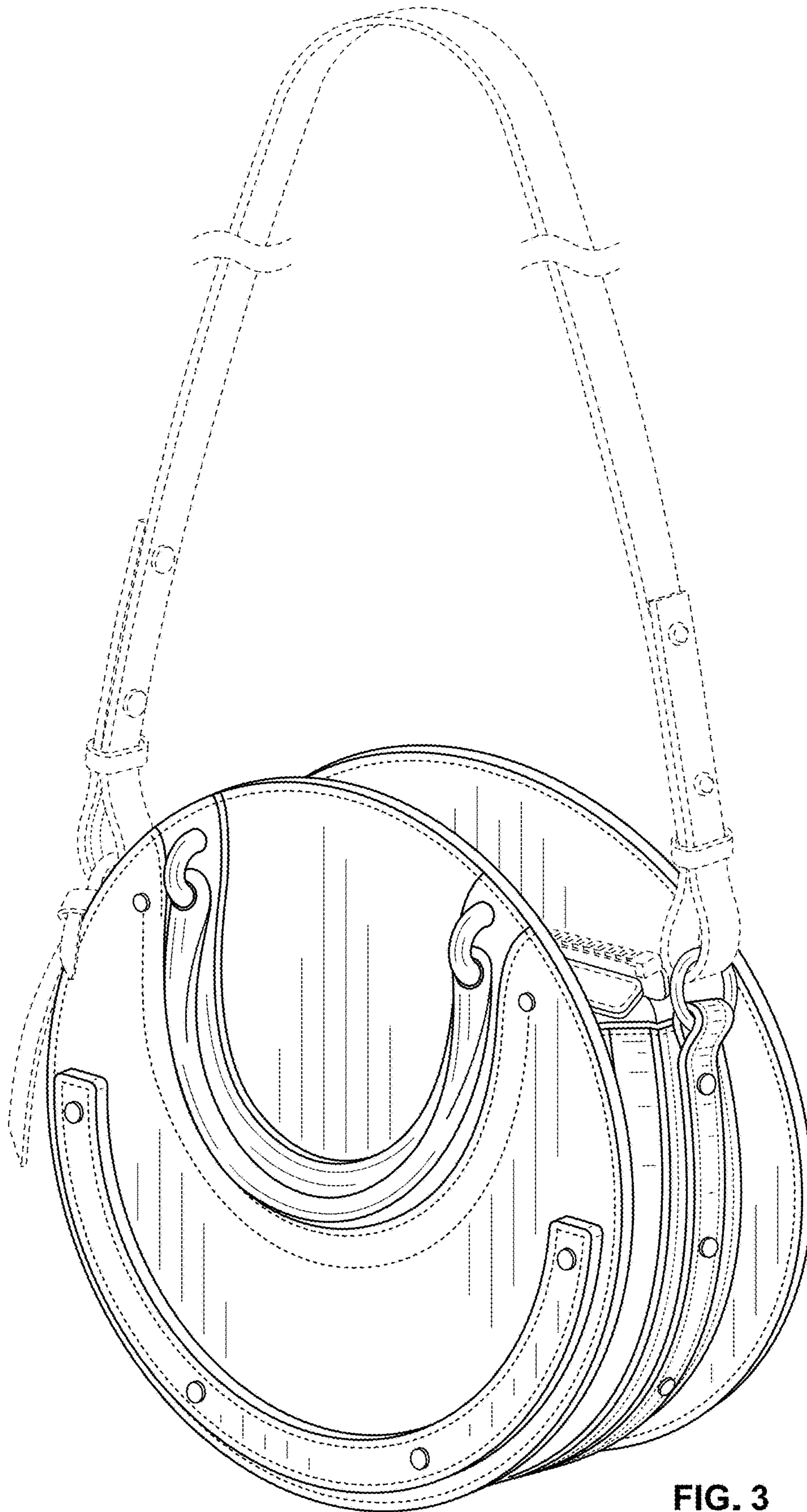

FIG. 3

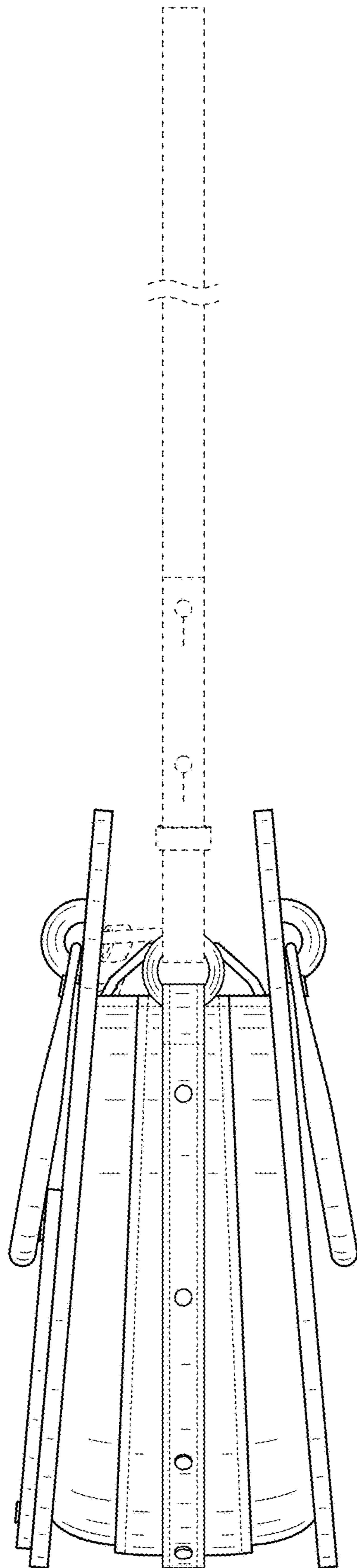

FIG. 4



FIG. 5

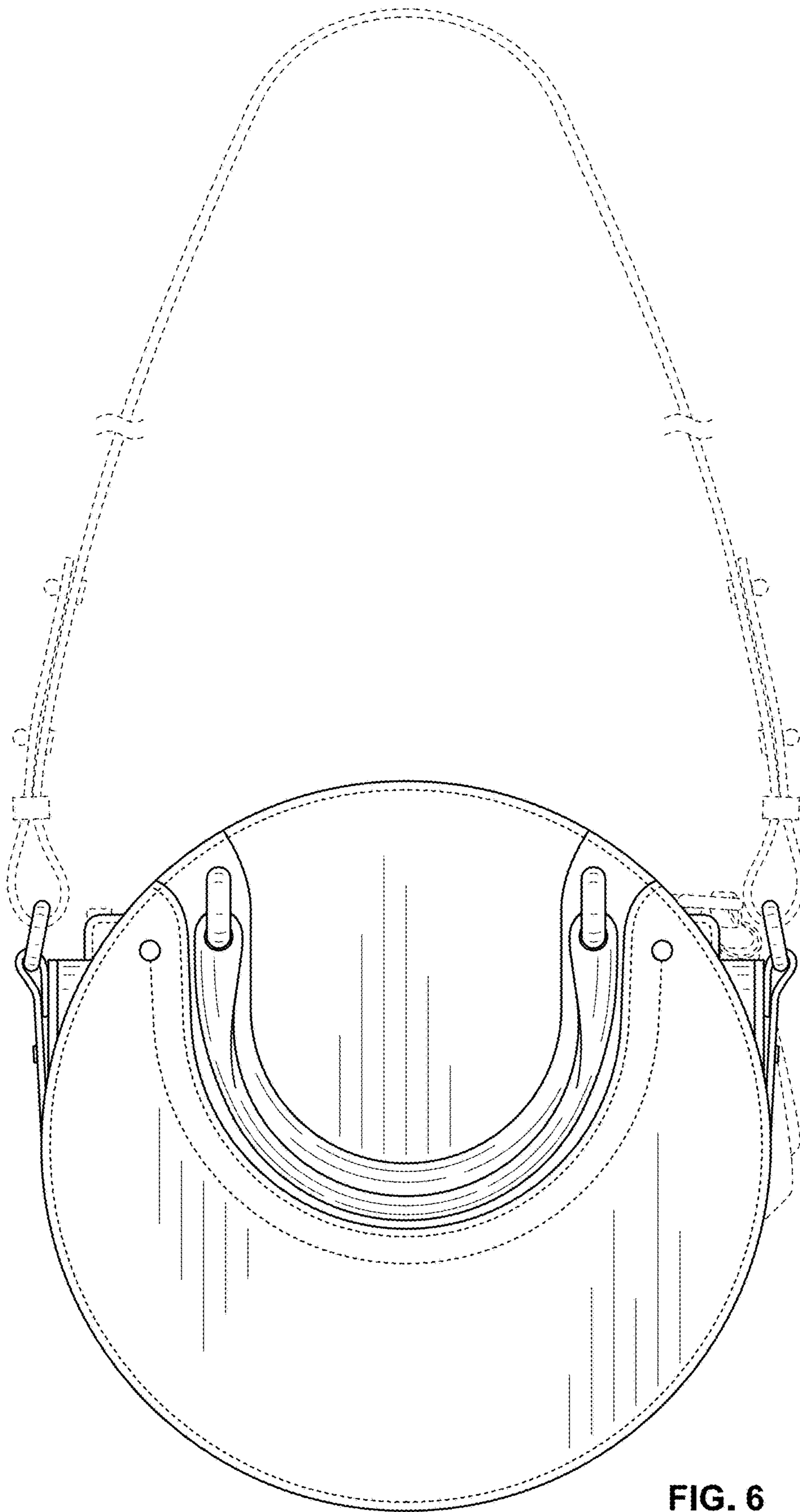

FIG. 6

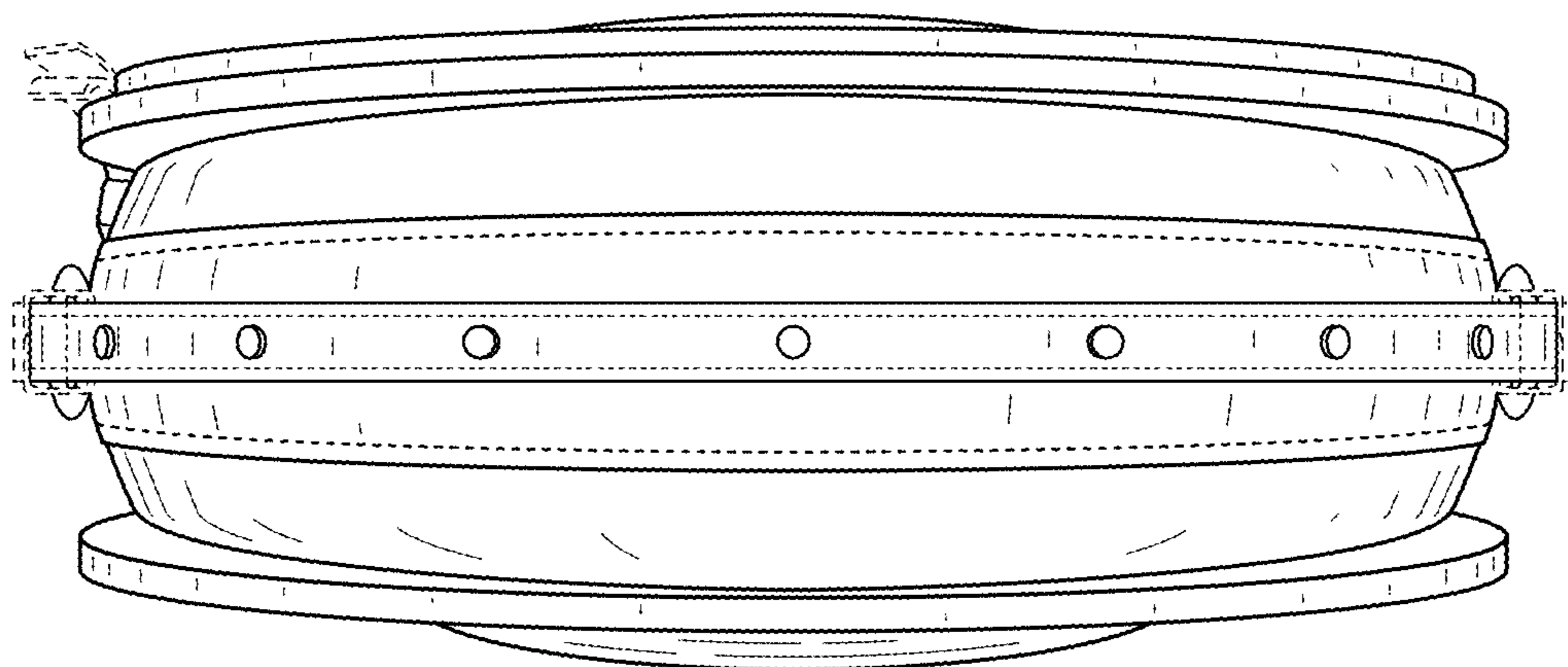

FIG. 7



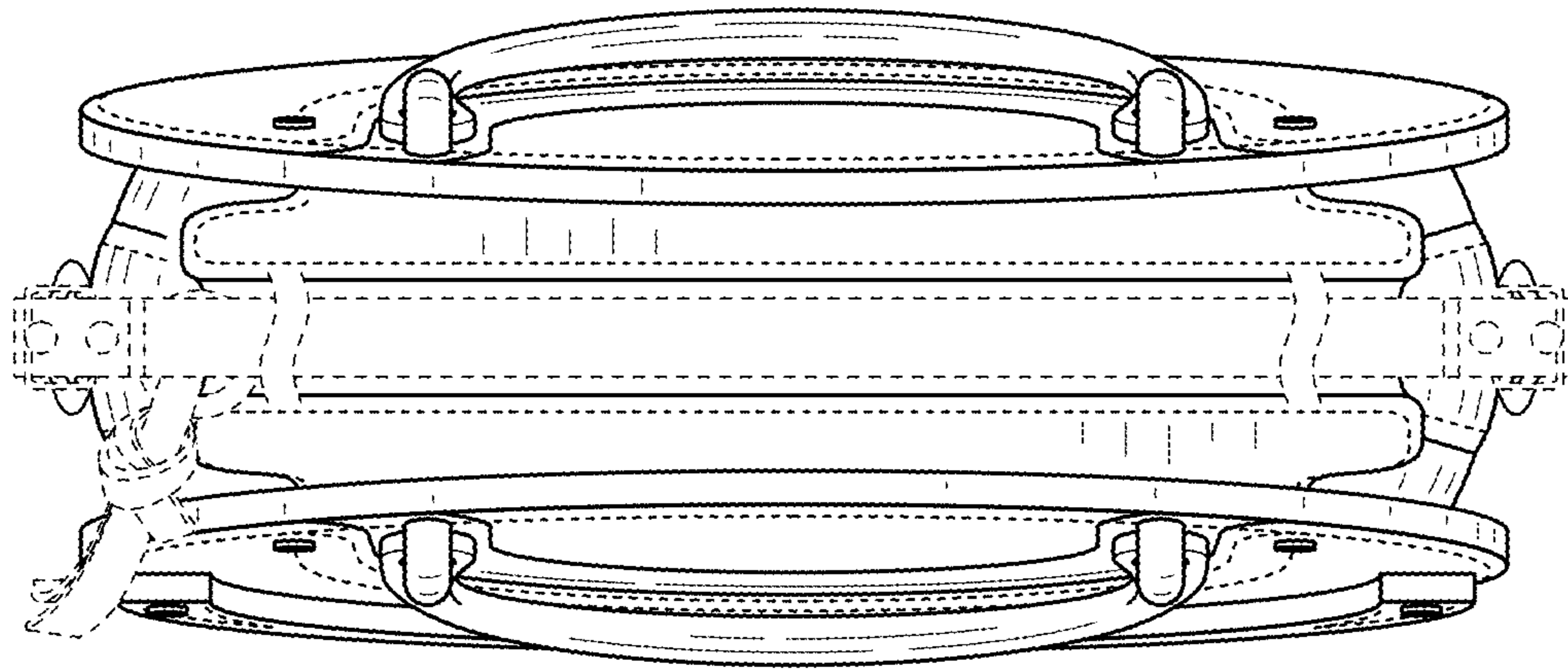

FIG. 8