

US00D846258S

(12) **United States Design Patent** (10) **Patent No.:** **US D846,258 S**
Gavrieli et al. (45) **Date of Patent:** **** Apr. 23, 2019**

(54) **DUAL-SOLE SHOE WITH COLOR
OUTPATCH SOLE**

(56) **References Cited**

U.S. PATENT DOCUMENTS

- (71) Applicant: **Gavrieli Brands LLC**, Beverly Hills, CA (US)
- (72) Inventors: **Kfir Gavrieli**, Beverly Hills, CA (US);
Dikla Gavrieli, Beverly Hills, CA (US)
- (73) Assignee: **Gavrieli Brands LLC**, Beverly Hills, CA (US)
- (**) Term: **15 Years**
- (21) Appl. No.: **29/595,523**
- (22) Filed: **Feb. 28, 2017**

Related U.S. Application Data

(63) Continuation of application No. 29/509,249, filed on Nov. 14, 2014, now Pat. No. Des. 781,034, which is a continuation of application No. 14/266,599, filed on Apr. 30, 2014, now Pat. No. 9,398,786, which is a continuation of application No. 13/207,397, filed on Aug. 10, 2011, now Pat. No. 8,745,893.

(51) **LOC (11) Cl.** **02-99**

(52) **U.S. Cl.**

USPC **D2/971**
 CPC **A43B 3/248** (2013.01); **A43B 3/10** (2013.01); **A43B 3/108** (2013.01); **A43B 3/12** (2013.01); **A43B 3/24** (2013.01); **A43B 5/12** (2013.01); **A43B 9/02** (2013.01); **A43B 13/122** (2013.01); **A43B 13/14** (2013.01); **A43B 13/141** (2013.01); **A43B 13/16** (2013.01); **A43B 13/186** (2013.01); **A43B 23/0245** (2013.01)

(58) **Field of Classification Search**

USPC D2/896, 900, 919-921, 925, 939, 947, D2/950, 969, 971

CPC A43B 21/00; A43B 21/02; A43B 21/06; A43B 9/14; A43B 1/0045; A43B 13/10; A43B 13/12; A43B 23/06; A43B 23/07; A43B 1/0036; A43B 5/12; A43B 3/248

See application file for complete search history.

249,086 A	11/1881	Pienovi	
773,850 A	11/1904	Cooper et al.	
830,941 A	9/1906	Walden	
1,208,209 A	12/1916	Prince	
1,214,666 A	2/1917	Ford	
1,519,009 A	12/1924	Reina	
1,525,848 A *	2/1925	Bonaventure	A43B 5/12 36/113
1,587,377 A	6/1926	Grosjean	
1,650,466 A	11/1927	Righter	
2,224,590 A	12/1940	Boivin	
2,268,777 A	1/1942	Scholl	
D133,819 S *	9/1942	Harris	D2/939
D135,791 S	6/1943	Beebe	
2,323,563 A	7/1943	Nugent	
2,342,882 A	2/1944	Meltzer	
D141,871 S	7/1945	Braun	
2,383,585 A	8/1945	Bindner	
D149,685 S *	5/1948	Sandler	D2/935
D150,729 S *	8/1948	Sandler	D2/923
D166,090 S *	3/1952	Maling	D2/897
2,772,488 A	12/1956	Meltzer	
2,904,814 A	9/1959	Scholl	
3,148,378 A	9/1964	Tibbitts	
D200,897 S *	4/1965	Mitchell	D2/919
D220,464 S	4/1971	Hayoshi	
D247,396 S *	3/1978	Schlerth	D2/939
4,412,393 A	11/1983	Terlizzi, Jr. et al.	
D275,525 S	9/1984	Nakao	
4,674,206 A	6/1987	Lyden	
D295,692 S *	5/1988	Zuidema	D2/950
D300,085 S	3/1989	Ito et al.	
RE33,018 E	8/1989	Ostrander	
4,899,412 A	2/1990	Ganon	
D316,773 S	5/1991	Valle	
5,012,541 A	5/1991	Ganon	
D339,669 S *	9/1993	Miller	D2/919
5,282,326 A	2/1994	Schroer, Jr. et al.	
5,421,050 A	6/1995	Laganas	
5,699,629 A	12/1997	Munschy	
5,746,014 A	5/1998	Tanemoto	
D420,785 S	2/2000	Perez	
6,055,745 A	5/2000	Endoh	
6,076,284 A	6/2000	Terlizzi	
6,189,239 B1	2/2001	Gasparovic et al.	
6,338,207 B1	1/2002	Chang	
D457,292 S *	5/2002	Sessa	D2/949
D461,947 S	8/2002	Merceron	
D476,798 S	7/2003	Reynolds et al.	

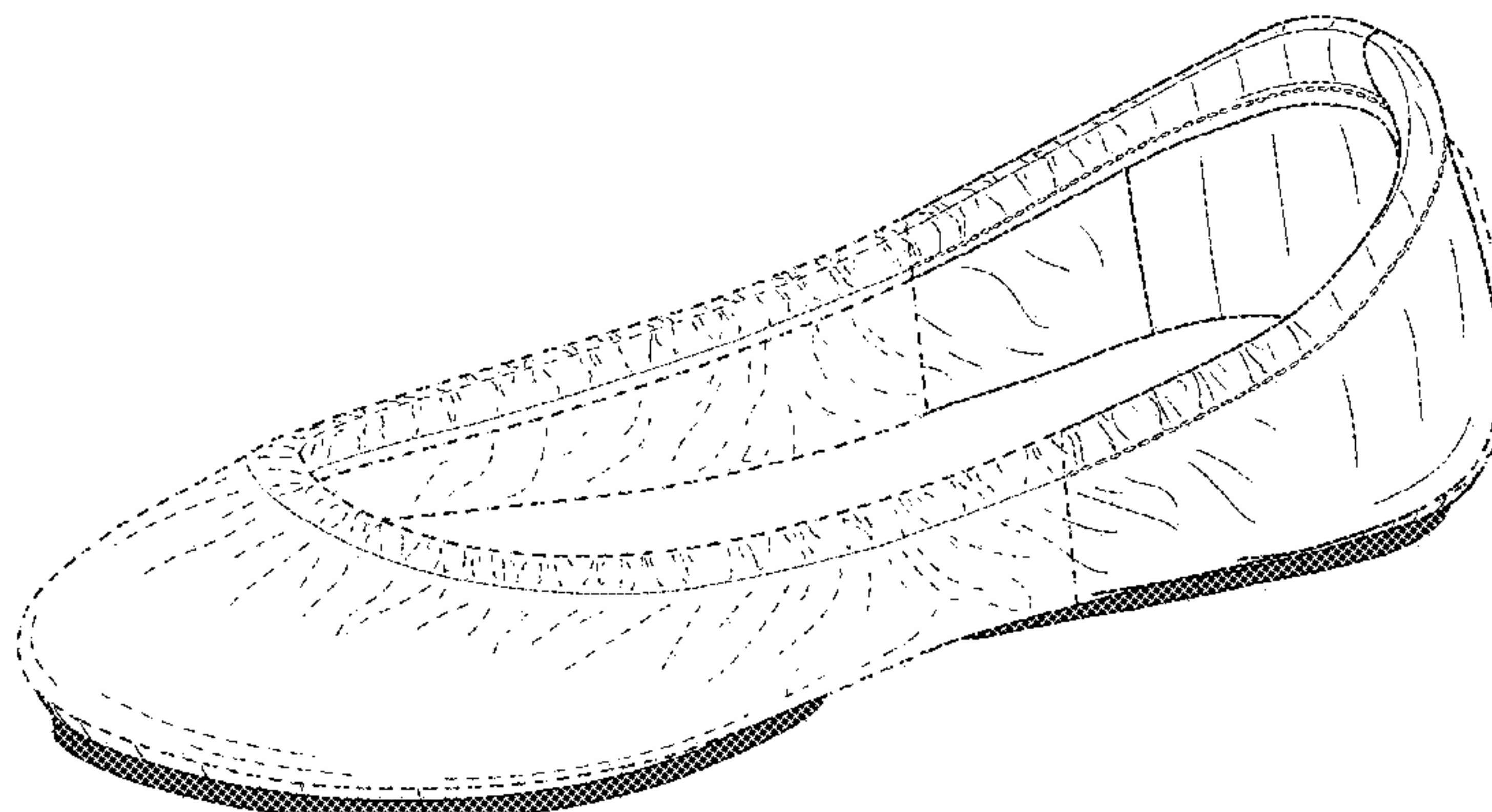

US D846,258 S

Page 2

6,588,124 B2	7/2003	Morrone		D689,271 S *	9/2013	Gavrieli	A43B 3/248
D498,041 S	11/2004	McClaskie						D2/939
D500,191 S *	12/2004	Belley	D689,272 S *	9/2013	Gavrieli	A43B 3/248
D501,706 S	2/2005	McClaskie						D2/939
6,857,203 B2	2/2005	Minden		D690,914 S *	10/2013	Gavrieli	A43B 3/248
6,895,693 B2	5/2005	Baruck						D2/939
6,978,557 B2	12/2005	Lee		D690,915 S *	10/2013	Gavrieli	A43B 3/248
7,032,327 B1	4/2006	Tartaglia et al.						D2/939
7,036,244 B1	5/2006	Finch		D696,500 S	12/2013	Hunt		
D527,513 S	9/2006	Della Valle		D699,424 S	2/2014	Hamm		
D529,513 S *	10/2006	Aketa	8,661,714 B2	3/2014	Sussman		
D531,790 S	11/2006	Wurzburg		8,745,893 B2 *	6/2014	Gavrieli	A43B 3/248
D534,341 S *	1/2007	Choi					36/8.3
D542,513 S	5/2007	Amado et al.		8,973,287 B2	3/2015	Shibata		
D556,990 S	12/2007	Cabados		9,398,786 B2 *	7/2016	Gavrieli	A43B 3/248
7,337,558 B2	3/2008	Terlizzi et al.		D781,034 S *	3/2017	Gavrieli	A43B 3/248
D567,485 S	4/2008	James						D2/939
D570,488 S	6/2008	Kirksey et al.		2002/0078591 A1	6/2002	Morrone		
D571,084 S	6/2008	Comeau		2002/0129519 A1	9/2002	Cahan		
D571,548 S	6/2008	Seamans		2003/0070319 A1	4/2003	Minden		
D571,989 S	7/2008	Siegal		2003/0121176 A1	7/2003	Baruck		
D580,640 S	11/2008	Wurzburg		2004/0025377 A1	2/2004	Brannon		
D582,638 S	12/2008	Ringholz		2005/0022421 A1	2/2005	Bruckner		
7,496,982 B2	3/2009	Clark et al.		2005/0115115 A1	6/2005	Lacey		
7,506,459 B2	3/2009	Grisoni et al.		2005/0217148 A1	10/2005	Connolly et al.		
D591,031 S	4/2009	Cofinco		2005/0262734 A1	12/2005	Cheng		
D593,295 S *	6/2009	Belley	2006/0086005 A1	4/2006	Yerian		
D593,297 S *	6/2009	Belley	2006/0156576 A1	7/2006	Sloan		
D593,307 S *	6/2009	Belley	2007/0074424 A1	4/2007	Lin		
D599,093 S *	9/2009	Issler	2007/0204482 A1	9/2007	Gibson-Collinson		
D604,030 S	11/2009	Wilson		2007/0204483 A1	9/2007	Kirsch et al.		
D607,194 S	1/2010	Zagula		2008/0052964 A1	3/2008	Taylor		
D610,332 S	2/2010	Raichle		2008/0086912 A1	4/2008	Wilkenfeld		
D610,785 S	3/2010	Smith		2008/0110059 A1	5/2008	Kuramoto et al.		
D612,140 S	3/2010	Moon		2009/0019732 A1	1/2009	Sussmann		
D612,141 S	3/2010	Moon		2009/0193685 A1	8/2009	Wilson		
7,694,435 B1	4/2010	Kiser et al.		2009/0205222 A1	8/2009	McLinden		
D615,737 S	5/2010	Feller		2009/0272009 A1	11/2009	Weisner et al.		
7,735,244 B1	6/2010	Ameche		2010/0011625 A1	1/2010	Percival		
7,743,530 B2	6/2010	Truelsen		2010/0018080 A1	1/2010	Smith		
D618,891 S	7/2010	McClaskie		2010/0050469 A1	3/2010	Chen		
7,757,408 B2	7/2010	McClaskie		2010/0095557 A1	4/2010	Jarvis		
D630,829 S	1/2011	Weisner		2010/0115793 A1	5/2010	Kraisosky		
D632,881 S	2/2011	Rosenberg		2010/0122475 A1	5/2010	Purrington		
7,926,203 B2	4/2011	Wilkenfeld		2010/0146822 A1	6/2010	MacGregor		
7,966,747 B2	6/2011	Wilkenfeld et al.		2010/0212186 A1	8/2010	Cheng		
D640,861 S	7/2011	Wilkenfeld		2010/0275462 A1	11/2010	Pucci		
8,020,320 B2	9/2011	Gillespie		2010/0281713 A1	11/2010	Pantazes		
8,127,468 B2	3/2012	Morgan		2015/0089843 A1	4/2015	Gavrieli		
D657,543 S	4/2012	Bove						
D659,960 S	5/2012	Bizzo						
8,230,619 B2	7/2012	Salvatelli						
D664,755 S	8/2012	Gavrieli et al.						
D665,157 S	8/2012	Wu						
8,240,067 B2	8/2012	Sussmann						
8,245,420 B2	8/2012	Wilson						
D668,027 S	10/2012	Millieret						
D668,438 S	10/2012	Millieret						
D668,847 S *	10/2012	Gavrieli					D2/925
D668,848 S *	10/2012	Gavrieli					D2/925
D668,849 S	10/2012	Pozzi						
D668,850 S	10/2012	Pozzi						
D672,542 S	12/2012	Gray et al.						
D676,634 S *	2/2013	Gavrieli					D2/925
D681,927 S *	5/2013	Gavrieli					D2/925
D681,928 S *	5/2013	Gavrieli					D2/925
D681,929 S *	5/2013	Gavrieli					A43B 3/248
								D2/939
D683,936 S *	6/2013	Gavrieli					D2/925
8,468,723 B2	6/2013	Malka-Harari						
8,510,975 B2	8/2013	Krikelis						
D688,853 S *	9/2013	Gavrieli					A43B 3/248
								D2/939
D688,854 S *	9/2013	Gavrieli					A43B 3/248
								D2/939
D688,855 S *	9/2013	Gavrieli					A43B 3/248
								D2/939
D689,270 S *	9/2013	Gavrieli					A43B 3/248
								D2/939

FOREIGN PATENT DOCUMENTS

DE	20 2006 000230	U1	5/2007
GB	2443937	A	5/2008
GB	2 446 205	A	8/2008
TW	D119165		10/2007

OTHER PUBLICATIONS

Examination Report for AU 341324, 3 pgs., dated Oct. 24, 2012.
 Letter from TMI and Associates with Office Action, 2 pgs, dated Sep. 19, 2012 <http://www.payless.com/store/?&TLC=Womens&SLC=WomensNewArrivals&BLC=WomensNewArrivalsNewArrivals&With+Regular&ItemCode=60131&LotNumber=062642&Type=Adult&Popularity=637&Descriptvein>.
 Taiwanese Office Action for TW 101300726, 10 pgs., dated Sep. 6, 2012.
 "The Love List, Tiefs by Gavrieli—Foldable Ballet Flats," <http://thelovelist-carly.blogspot.com.au/2010/09/tiefs-by-gavrieli-foldable-ballet.html>, 3 pgs., Sep. 12, 2010.
 "Tiefs by Gavrieli," <http://tiefs.com>, 1 pg., retrieved Mar. 13, 2013 from URL.
 "Try It Mummy!, Tiefs by Gavrieli," <http://tryitmummy.blogspot.com.au/2010/12/tiefs-by-gavrieli.html>, 4 pgs., Dec. 9, 2010.
 "Wearability—Real People Style, What came first, the City Flat or the Tiefs," <http://wearability.posterous.com/what-came-first-the-city-flat-or-the-tiefs>, 4 pgs., Aug. 29, 2010.

“The Ballet Flat . . . Reinvented; Ballet Flats . . . with a Bonus; Step Into Tieks; Going Places? Take Tieks,” <http://web.archive.org/web/2010052004346/http://www.tieks.com/>; 4 pgs., May 24, 2010.

“Tieks—Comfortable designer flats you can fit in your purse and wear all day, every day,” <http://web.archive.org/web/20110731151555/http://tieks.com/>; 6 pgs., Jul. 31, 2011.

“58th Annual Emmy Awards,” http://spoonsforksandfashion.blogspot.com/2006_08_01_archive.html, depicting Nine West flats, 11 pgs., Aug. 1, 2006.

Pictures of Nine West flats sold in 2006, 3 pgs.

“I Love a Good Ballet Flat!,” <http://dressupfiles.com/i-love-a-good-ballet-flat>, depicting Sue London flats, 4 pgs., Sep. 3, 2010.

Pictures of Sue London flats sold in 2010, 2 pgs.

“Miss Cathie Reviews: The Yosi Samra Foldable Ballet Flat . . .,” <http://www.misscathie.com/2010/01/miss-cathie-reviews-the-yosi-samra-foldable-ballet-flat/>, depicting Yosi Samra flats, 7 pgs., Jan. 2010.

Pictures of Yosi Samra flats sold in 2010, 2 pgs.

“Goodbye two thousand ten,” http://emmajoyrussell.blogspot.com/2010_12_01_archive.html, depicting Gap flats, 39 pgs., Dec. 1, 2010.

Pictures of Gap flats available for sale in 2010, 9 pgs.

“Our newest design of folding flats—Pink,” <https://fitinclouds.wordpress.com/2010/05/16/our-newest-design-of-folding-flats-pink/>, depicting Fit in Clouds flats, 1 pg., May 16, 2010.

“Fit in Clouds Satin Folding Shoes,” <http://www.goodhousekeeping.com/product-reviews/clothing/best-ballet-flats/fit-in-clouds-satin-foldable-ballet-flats>, depicting Fit in Clouds flats, 1 pg., Aug. 2013.

Pictures of Fit in Clouds flats available for sale in 2011, 4 pgs.

“Shoes for Standing,” <https://truthinshoes.wordpress.com/2008/07/>, depicting Sam & Libby flats, 2 pgs., Jul. 31, 2008.

“Target Designer Collaboration: Announcing Sam & Libby Shoes for Target,” <http://www.therecessionista.com/2012/11/target-designer-collaboration-announcing-sam-libby-shoes-for-target.html>, depicting Sam & Libby flats, 1 pg., Nov. 26, 2012.

Pictures of Sam & Libby flats available for purchase in 2011, 5 pgs.

“Save your soles with Citisoles ballet flats,” <http://glamazondiaries.com/2009/07/save-your-soles-with-citisoles-ballet-flats>, depicting Citisoles flats, 3 pgs., Jul. 2009.

Pictures of Citisoles flats available for purchase in 2009, 3 pgs.

“#16 Corso Como Delicious Pumps Review and Giveaway!,” <http://www.mommatoldmeblog.com/2011/01/16-corso-como-delicious-pumps-review.html>, depicting Corso Como flats, 8 pgs., Jan. 16, 2011.

Pictures of Corso Como flats available for sale in 2011, 3 pgs.

“Jil-sander-navy-lead-ballet-flats-product . . .,” www.ebay.com, depicting Jil Sander flats, 4 pgs., Nov. 2013.

Pictures of Jil Sander flats available for sale in 2011, 3 pgs.

“Spare Soles: Shoes That Roll-up & Fold-up,” <http://herpackinglist.com/2011/01/spare-soles-shoes/>, depicting Spare Soles flats, 2 pgs., Jan. 2011.

Pictures of Spare Soles flats available for sale in 2011, 5 pgs.

The Original Rollable, Foldable ballet flats with matching wristlet—Spare Soles, <http://herpackinglist.com/2011/01/spare-soles-shoes/>, depicting Roll-Upz Spare Soles flats, 2 pgs., Jan. 2011.

Pictures of Roll-Upz by Spare Soles flats available for sale in 2011, 6 pgs.

“The Cutest Blog, Preppy 50 and Loving Lilly, Ballet Flat Delight,” <http://preppy50andlovinglilly.blogspot.com/2011/02/ballet-flat-delight.html>, depicting Henri Bendel flats, 13 pgs., Feb. 19, 2011.

Pictures of Henri Bendel flats available for sale in 2011, 4 pgs.

“Mumsnet by parents for parents,” http://www.mumsnet.com/Talk/style_and_beauty/a1612000-Anyone-tried-Redfoot-Flatmates-foldable-ballet-pumps, depicting Redfoot Flatmates flats, 1 pg, Nov. 14, 2012.

Pictures of Redfoot Flatmates flats available for sale in 2011, 6 pgs.

“Amazon.com: Customer Reviews: Bloch London Women’s Lux Ballet Flat,” <http://www.amazon.com/Bloch-London-Womens-Ballet-Flat/product-reviews/B004LWP7YW>, depicting Bloch London flats, 4 pgs., Dec. 11, 2011.

Pictures of Bloch London flats offered for sale in 2011, 11 pgs.

“h&m foldable leopard print flat,” <http://845shops.wordpress.com/2011/06/16/flats-for-7-bucks/shoe1/>, depicting h&m flats, 3 pgs., Jun. 16, 2011.

Pictures of h&m foldable flats offered for sale in 2011, 4 pgs.

“Seekyt—Juicy Couture Ballet Flats—Are They Worth The Money?,” <http://seekyt.com/juicy-couture-ballet-flats-are-they-worth-the-money/>, 14 pgs., Jun. 3, 2011.

Pictures of Juicy Couture flats offered for sale in 2011, 3 pgs.

“Purse Flats,” <http://purseflats.wordpress.com>, depicting Purse Flats by Erica Wilson, 3 pgs., Jul. 12, 2012.

Pictures of Purse Flats by Erica Wilson offered for sale in 2011, 6 pgs.

“Splash Page,” <http://web.archive.org/web/20100524004346/http://www.tieks.com/>, 4 pgs., May 24, 2010.

“Tieks by Gavrieli—Comfortable, designer flats you can fit in your purse and wear all day . . .,” <http://web.archive.org/web/20110202210649/http://www.tieks.com/>, 8 pgs., Feb. 2, 2011.

“Carolina M. M. Gonzalez > Tieks by Gavrieli,” <http://m2.facebook.com/Tieks?v=timeline&filter=2&timecutoff=1406427986&page=17>

§ionLoadingID=m_timeline_loading_div_1293868799_1262332800_8_17&timeend=1293868799×tart=1262332800&tm=AQDOvqhWQPN_Nbwm&refid=17, 1 pg. Jan. 26, 2010.

“The Shoes Oprah Would Wear to Work (if She Had to Walk),” <http://www.inc.com/30under30/christina-desmarais/kfir-gavrieli-and-elram-gavrieli-founders-of-tieks.html>, 8 pgs., Jul. 2, 2012.

“Tieks by Gavrieli,” http://m2.facebook.com/Tieks?v=timeline&filter=2&timecutoff=1406427986&page=14§ionLoadingID=m_timeline_loading_div_1293868799_1262332800_8_14&timeend=1293868799×tart=1262332800&tm=AQDOvqhWQPN_Nbwm&refid=17, 4 pgs., Jan. 26, 2010.

“Mighty Life List, Sensible Shoes,” <http://mightygirl.com/2010/08/24/sensible-shoes/>, 10 pgs., Aug. 24, 2010.

“Find! Tieks: Fab & sexy flats for fall,” <http://thefabmom.com/2013/08/29/find-tieks-fab-sexy-flat-for-fall/>, 3 pgs. Aug. 29, 2013.

“Step into Tieks,” <http://sliceofpink.typepad.com/blog/2010/09/tieks-1.html>, 5 pgs., Sep. 22, 2010.

“In Need of Flat-Soled Shoes,” <http://sliceofpink.typepad.com/blog/2010/09/tieks-1.html>, 7 pgs., Oct. 3, 2010.

“Say Hello to the Flat Shoes You Need for Fall . . . All 88 of Them!”, Picture of Adam Tucker Shoe/Slipper, <https://www.facebook.com/search/top/?q=adam%20shoes%20slipper>, last accessed Oct. 28, 2016, dated Oct. 1, 2013, 1 page.

Picture of Adam Tucker Rainbow Shoes, <https://www.facebook.com/search/top/?q=adam%20shoes%20rainbow>, last accessed Oct. 28, 2016, dated Aug. 14, 2013, 1 page.

* cited by examiner

Primary Examiner — Dominic V Simone

(74) *Attorney, Agent, or Firm* — Morgan, Lewis & Bockius LLP

(57) **CLAIM**

An ornamental design for a dual-sole shoe with color outpatch sole, as shown and described.

DESCRIPTION

The file of this patent contains at least one drawing executed in color. Copies of this patent with color drawing(s) will be provided by the Office upon request and payment of the necessary fee.

FIG. 1 is a perspective view of an embodiment of our new design of a dual-sole shoe with color outpatch sole;

FIG. 2 is a first side view of the design of FIG. 1;

FIG. 3 is a second side view of the design of FIG. 1;

FIG. 4 is a top view of the design of FIG. 1;

FIG. 5 is a bottom view of the design of FIG. 1;

FIG. 6 is a front view of the design of FIG. 1;

FIG. 7 is a back view of the design of FIG. 1;

FIG. 8 is a perspective view of another embodiment of our new design of a dual-sole shoe with color outpatch sole;
 FIG. 9 is a first side view of the design of FIG. 8;
 FIG. 10 is a second side view of the design of FIG. 8;
 FIG. 11 is a top view of the design of FIG. 8;
 FIG. 12 is a bottom view of the design of FIG. 8;
 FIG. 13 is a front view of the design of FIG. 8;
 FIG. 14 is a back view of the design of FIG. 8;
 FIG. 15 is a perspective view of yet another embodiment of our new design of a dual-sole shoe with color outpatch sole;
 FIG. 16 is a first side view of the design of FIG. 15;
 FIG. 17 is a second side view of the design of FIG. 15;
 FIG. 18 is a top view of the design of FIG. 15;
 FIG. 19 is a bottom view of the design of FIG. 15;
 FIG. 20 is a front view of the design of FIG. 15;
 FIG. 21 is a back view of the design of FIG. 15;
 FIG. 22 is a perspective view of yet another embodiment of our new design of a dual-sole shoe with color outpatch sole;
 FIG. 23 is a first side view of the design of FIG. 22;
 FIG. 24 is a second side view of the design of FIG. 22;
 FIG. 25 is a top view of the design of FIG. 22;
 FIG. 26 is a bottom view of the design of FIG. 22;
 FIG. 27 is a front view of the design of FIG. 22;
 FIG. 28 is a back view of the design of FIG. 22;
 FIG. 29 is a perspective view of yet another embodiment of our new design of a dual-sole shoe with color outpatch sole;
 FIG. 30 is a first side view of the design of FIG. 29;
 FIG. 31 is a second side view of the design of FIG. 29;
 FIG. 32 is a top view of the design of FIG. 29;
 FIG. 33 is a bottom view of the design of FIG. 29;
 FIG. 34 is a front view of the design of FIG. 29;
 FIG. 35 is a back view of the design of FIG. 29;
 FIG. 36 is a perspective view of yet another embodiment of our new design of a dual-sole shoe with color outpatch sole;
 FIG. 37 is a first side view of the design of FIG. 36;
 FIG. 38 is a second side view of the design of FIG. 36;
 FIG. 39 is a top view of the design of FIG. 36;
 FIG. 40 is a bottom view of the design of FIG. 36;
 FIG. 41 is a front view of the design of FIG. 36;
 FIG. 42 is a back view of the design of FIG. 36;
 FIG. 43 is a perspective view of yet another embodiment of our new design of a dual-sole shoe with color outpatch sole;
 FIG. 44 is a first side view of the design of FIG. 43;
 FIG. 45 is a second side view of the design of FIG. 43;
 FIG. 46 is a top view of the design of FIG. 43;
 FIG. 47 is a bottom view of the design of FIG. 43;
 FIG. 48 is a front view of the design of FIG. 43;
 FIG. 49 is a back view of the design of FIG. 43;
 FIG. 50 is a perspective view of yet another embodiment of our new design of a dual-sole shoe with color outpatch sole;
 FIG. 51 is a first side view of the design of FIG. 50;
 FIG. 52 is a second side view of the design of FIG. 50;
 FIG. 53 is a top view of the design of FIG. 50;
 FIG. 54 is a bottom view of the design of FIG. 50;
 FIG. 55 is a front view of the design of FIG. 50;
 FIG. 56 is a back view of the design of FIG. 50;
 FIG. 57 is a perspective view of yet another embodiment of our new design of a dual-sole shoe with color outpatch sole;
 FIG. 58 is a first side view of the design of FIG. 57;

FIG. 59 is a second side view of the design of FIG. 57;
 FIG. 60 is a top view of the design of FIG. 57;
 FIG. 61 is a bottom view of the design of FIG. 57;
 FIG. 62 is a front view of the design of FIG. 57;
 FIG. 63 is a back view of the design of FIG. 57;
 FIG. 64 is a perspective view of yet another embodiment of our new design of a dual-sole shoe with color outpatch sole;
 FIG. 65 is a first side view of the design of FIG. 64;
 FIG. 66 is a second side view of the design of FIG. 64;
 FIG. 67 is a top view of the design of FIG. 64;
 FIG. 68 is a bottom view of the design of FIG. 64;
 FIG. 69 is a front view of the design of FIG. 64;
 FIG. 70 is a back view of the design of FIG. 64;
 FIG. 71 is a perspective view of yet another embodiment of our new design of a dual-sole shoe with color outpatch sole;
 FIG. 72 is a first side view of the design of FIG. 71;
 FIG. 73 is a second side view of the design of FIG. 71;
 FIG. 74 is a top view of the design of FIG. 71;
 FIG. 75 is a bottom view of the design of FIG. 71;
 FIG. 76 is a front view of the design of FIG. 71;
 FIG. 77 is a back view of the design of FIG. 71;
 FIG. 78 is a perspective view of yet another embodiment of our new design of a dual-sole shoe with color outpatch sole;
 FIG. 79 is a first side view of the design of FIG. 78;
 FIG. 80 is a second side view of the design of FIG. 78;
 FIG. 81 is a top view of the design of FIG. 78;
 FIG. 82 is a bottom view of the design of FIG. 78;
 FIG. 83 is a front view of the design of FIG. 78;
 FIG. 84 is a back view of the design of FIG. 78;
 FIG. 85 is a perspective view of yet another embodiment of our new design of a dual-sole shoe with color outpatch sole;
 FIG. 86 is a first side view of the design of FIG. 85;
 FIG. 87 is a second side view of the design of FIG. 85;
 FIG. 88 is a top view of the design of FIG. 85;
 FIG. 89 is a bottom view of the design of FIG. 85;
 FIG. 90 is a front view of the design of FIG. 85;
 FIG. 91 is a back view of the design of FIG. 85;
 FIG. 92 is a perspective view of yet another embodiment of our new design of a dual-sole shoe with color outpatch sole;
 FIG. 93 is a first side view of the design of FIG. 92;
 FIG. 94 is a second side view of the design of FIG. 92;
 FIG. 95 is a top view of the design of FIG. 92;
 FIG. 96 is a bottom view of the design of FIG. 92;
 FIG. 97 is a front view of the design of FIG. 92;
 FIG. 98 is a back view of the design of FIG. 92;
 FIG. 99 is a perspective view of yet another embodiment of our new design of a dual-sole shoe with color outpatch sole;
 FIG. 100 is a first side view of the design of FIG. 99;
 FIG. 101 is a second side view of the design of FIG. 99;
 FIG. 102 is a top view of the design of FIG. 99;
 FIG. 103 is a bottom view of the design of FIG. 99;
 FIG. 104 is a front view of the design of FIG. 99; and,
 FIG. 105 is a back view of the design of FIG. 99.
 The broken lines illustrating the front portion of the upper, the half moon patch, and the heel stripe in the above described Figures are for illustrative purposes only and form no part of the claimed design.

**1 Claim, 90 Drawing Sheets
 (75 of 90 Drawing Sheet(s) Filed in Color)**

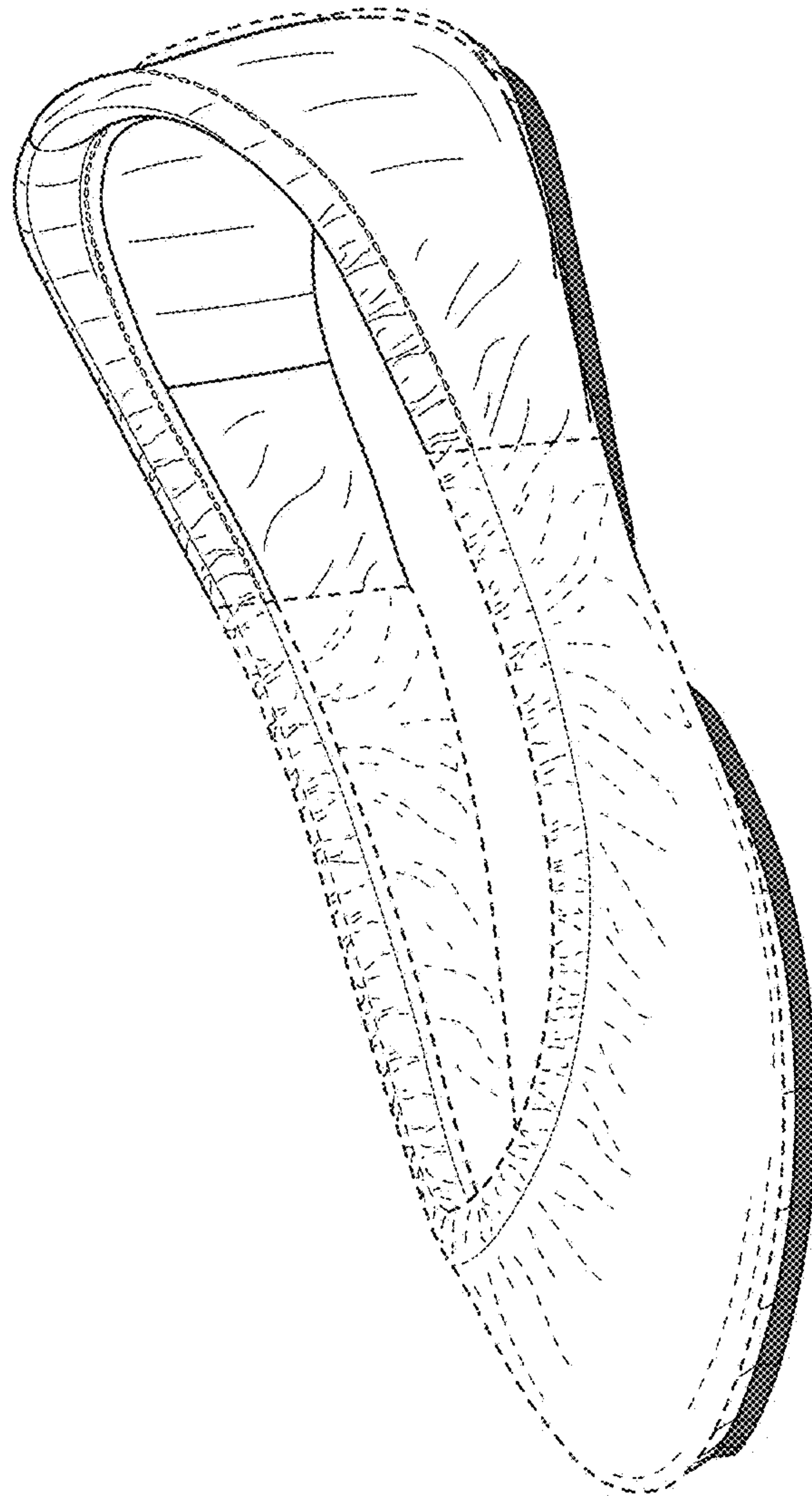

FIG. 1

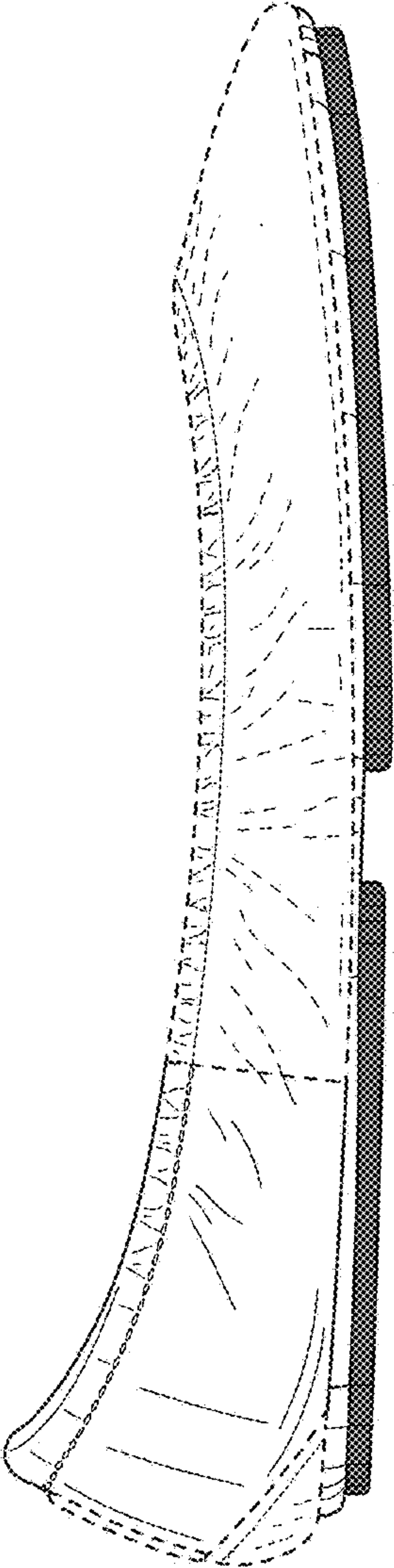

FIG. 2

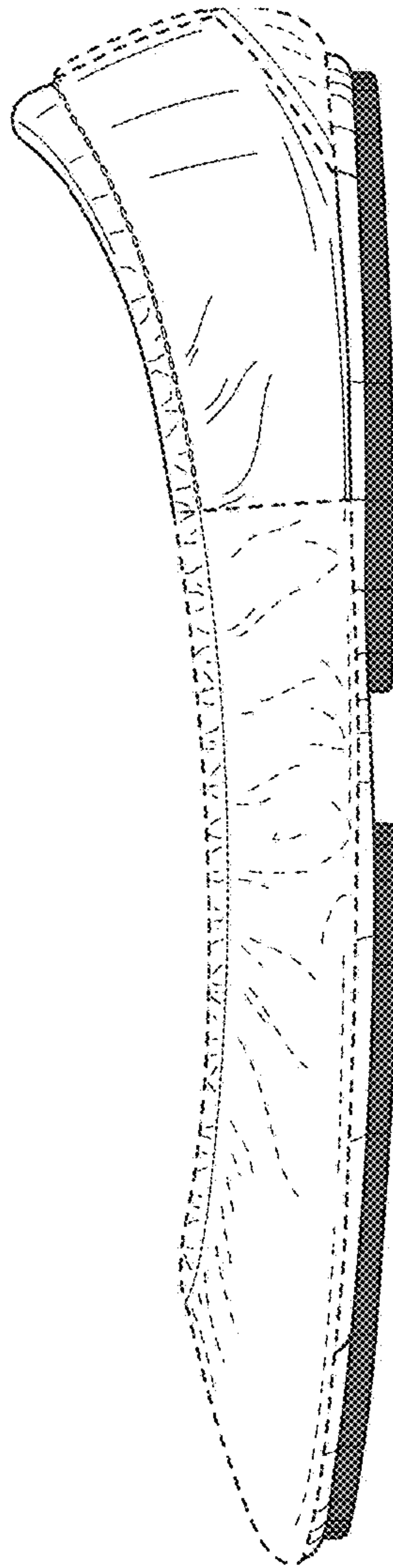

FIG. 3

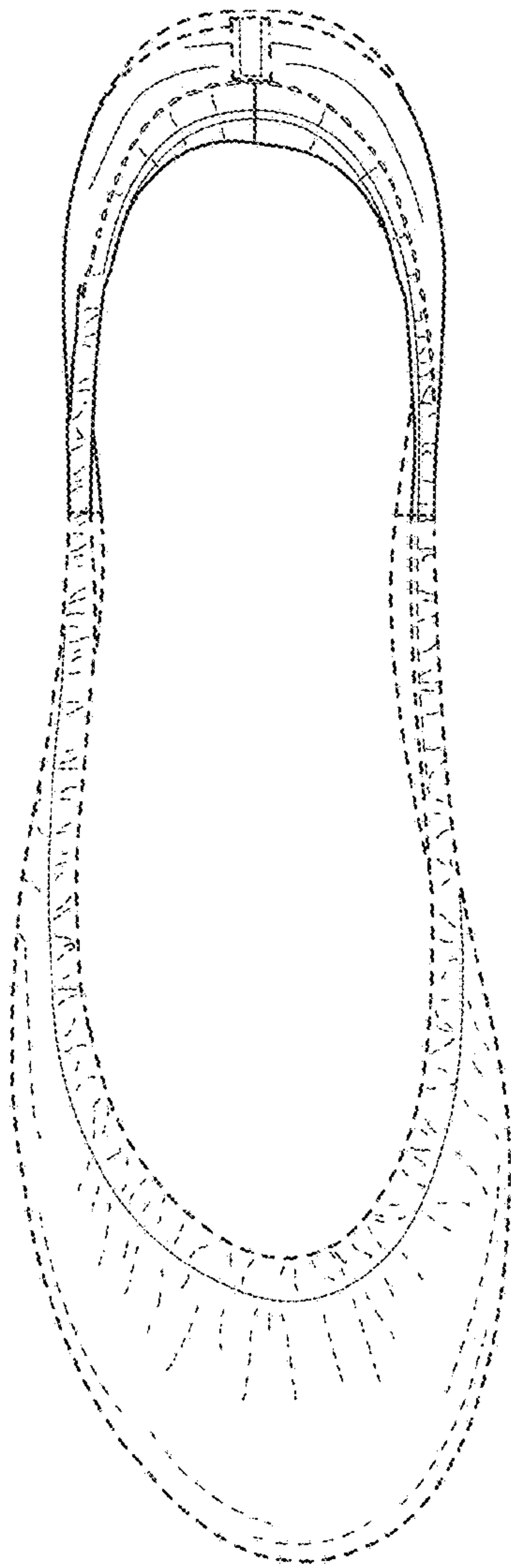

FIG. 4

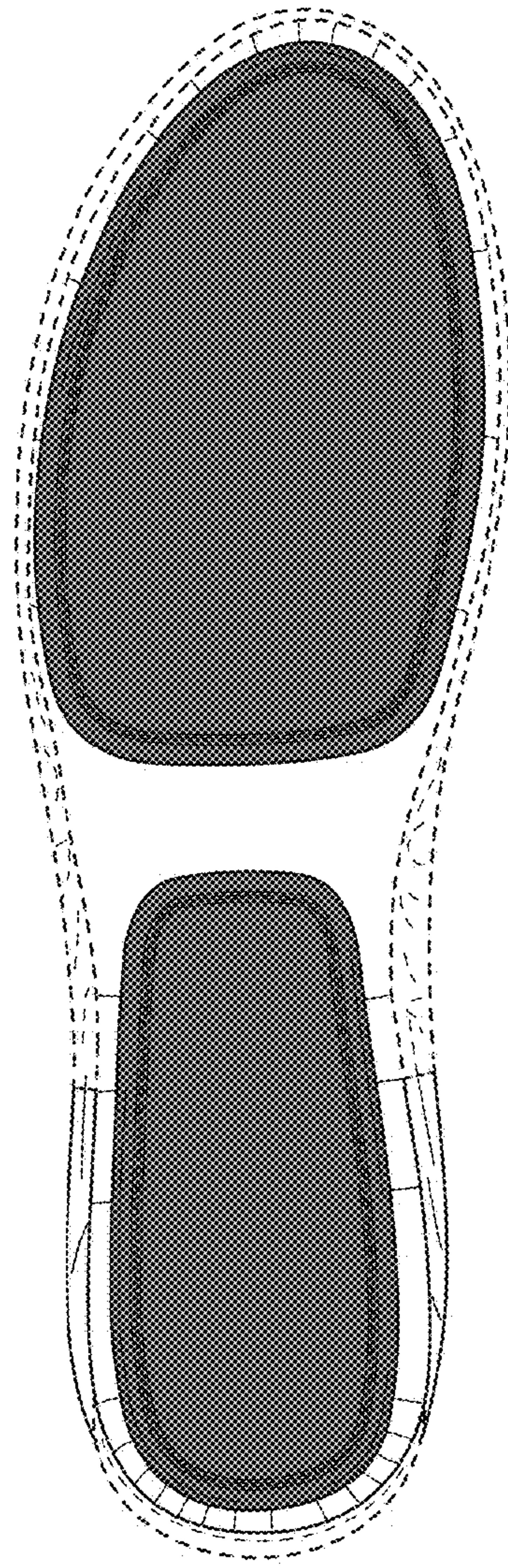

FIG. 5

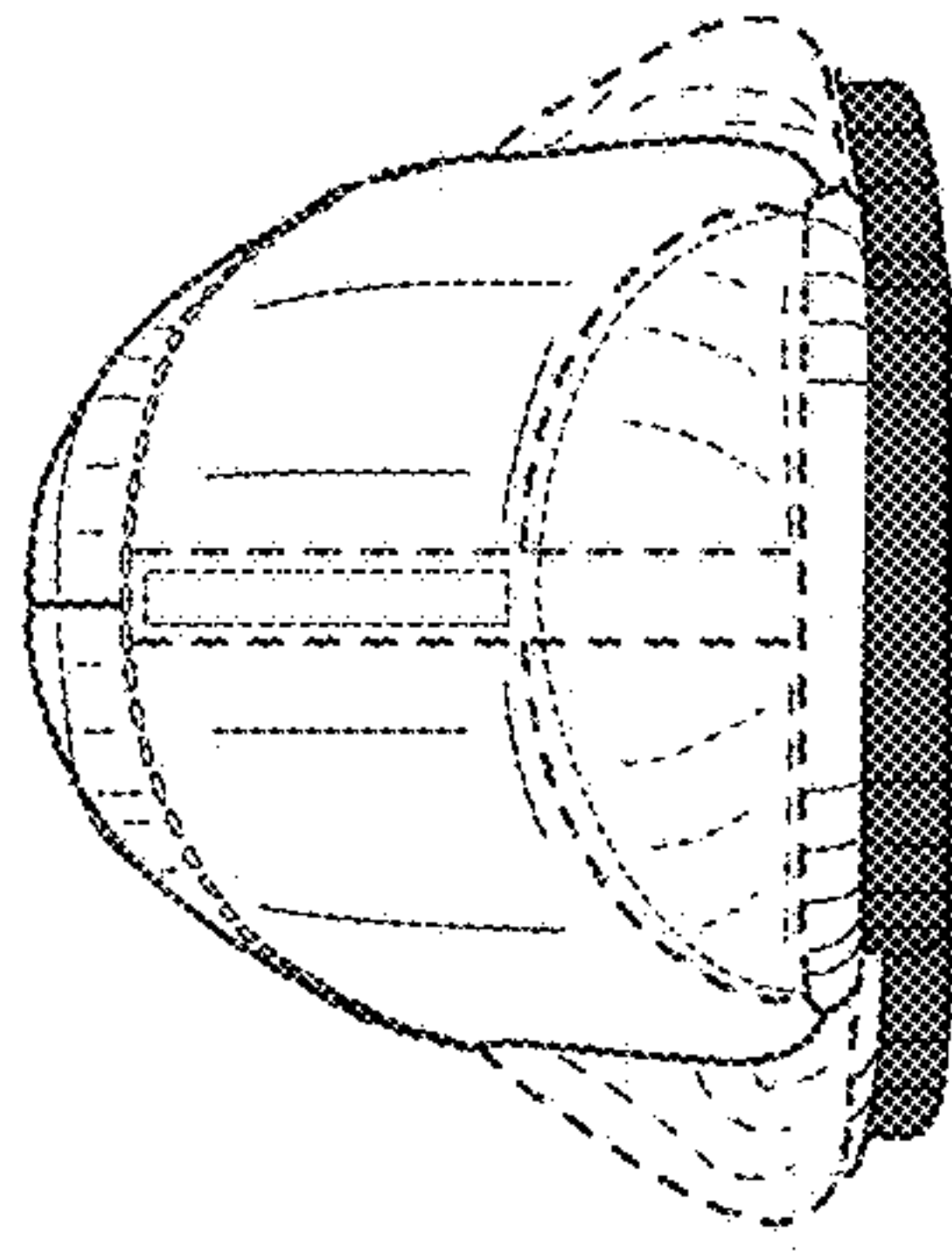

FIG. 7

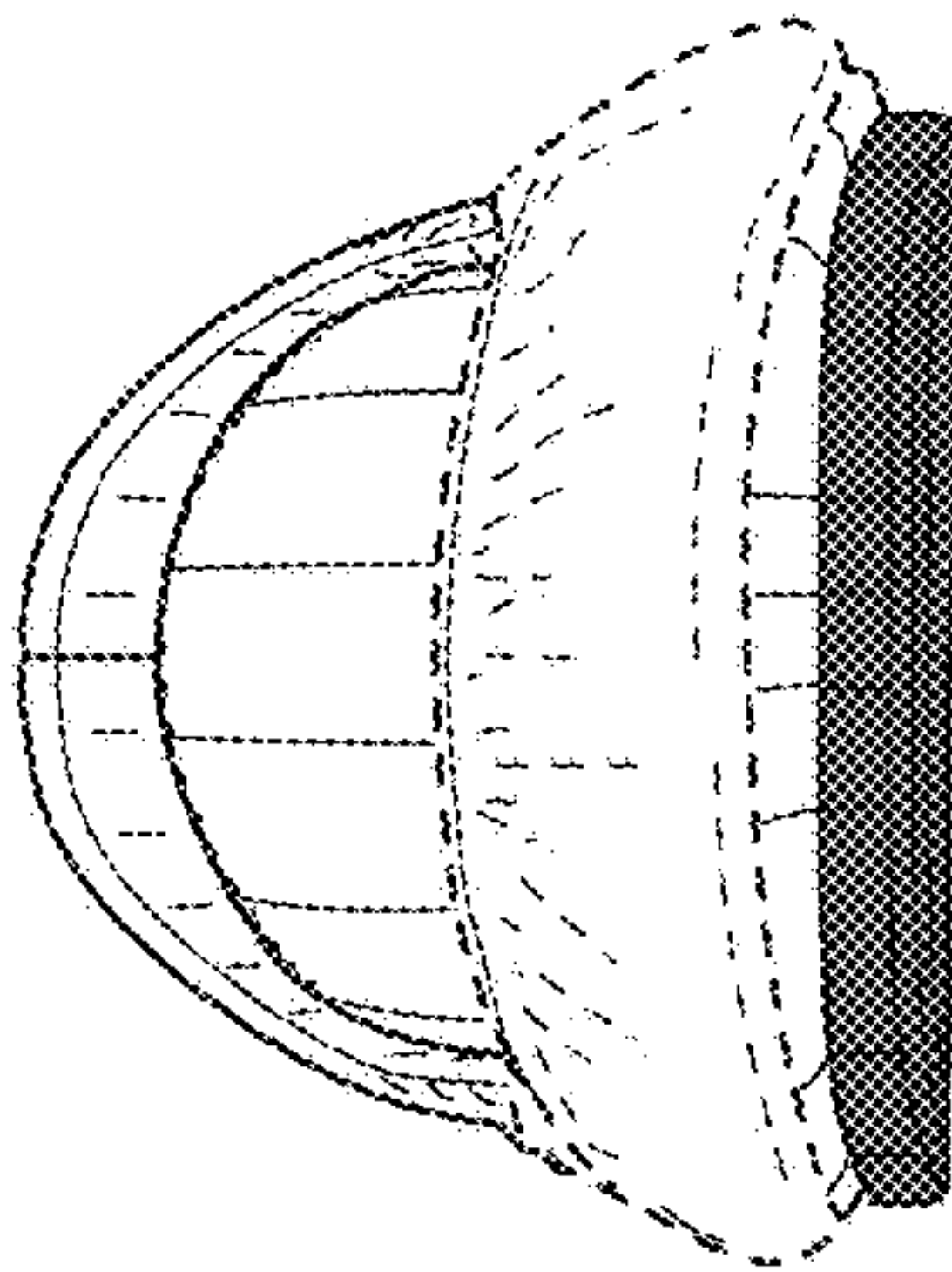

FIG. 6

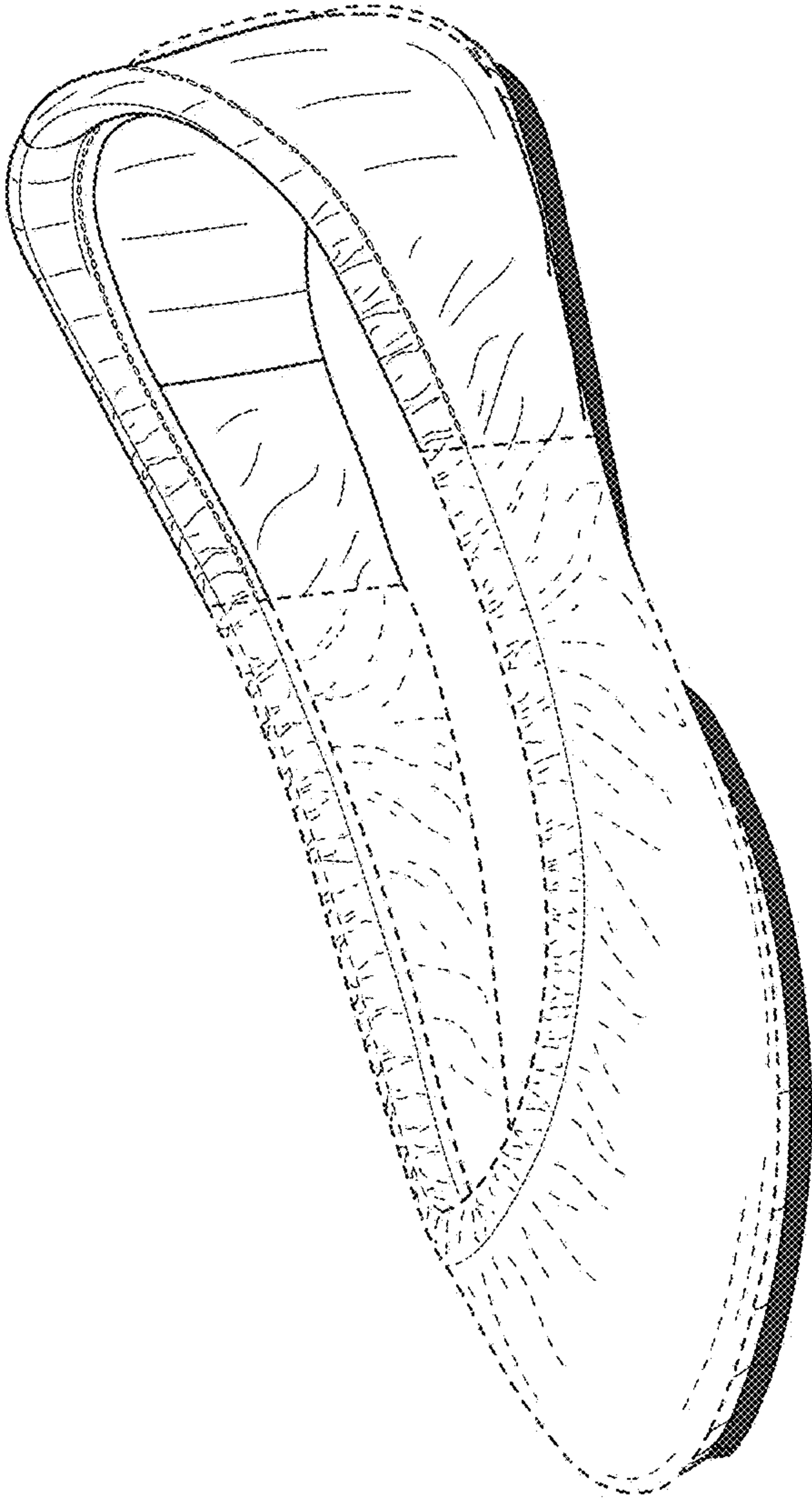

FIG. 8

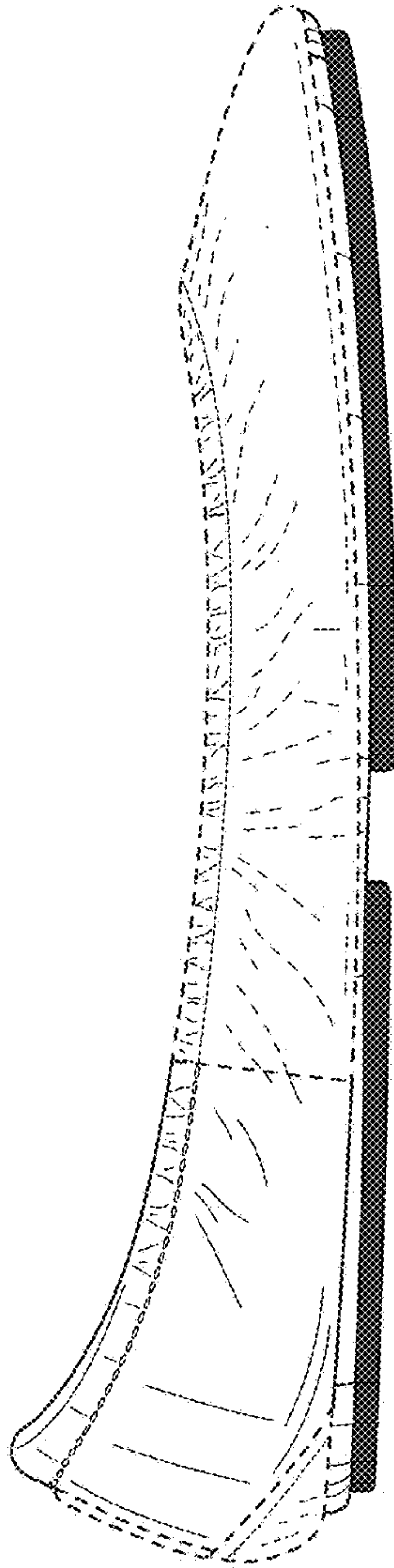

FIG. 9

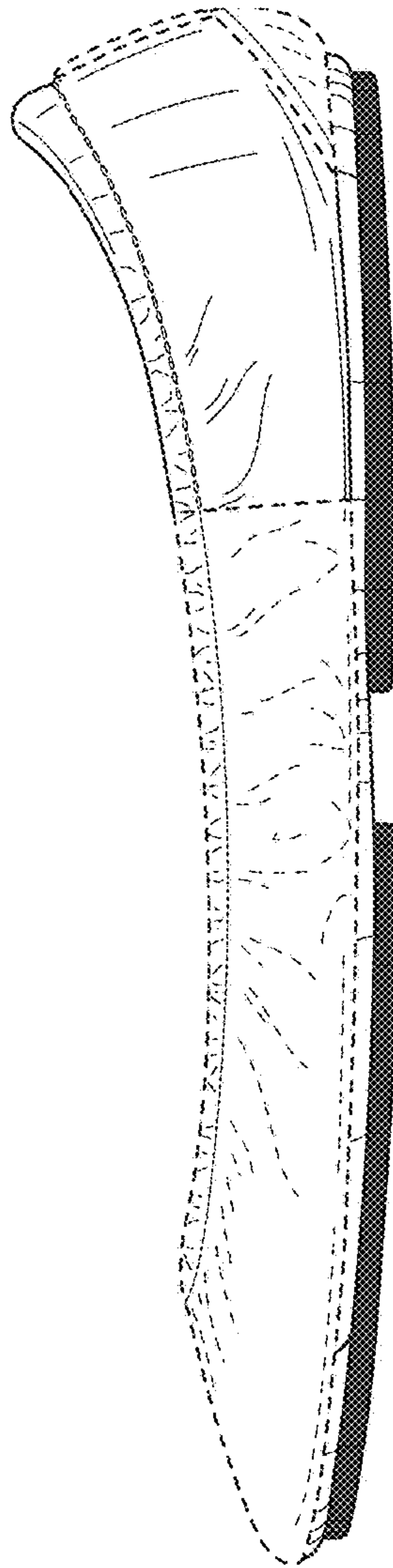

FIG. 10

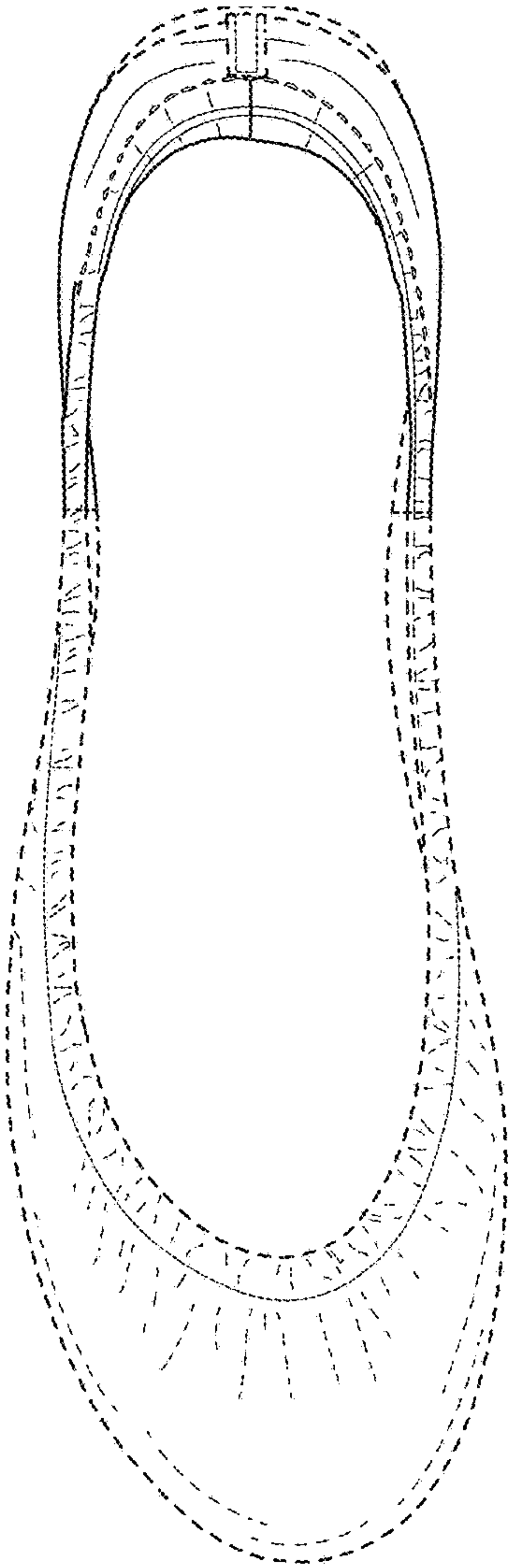

FIG. 11

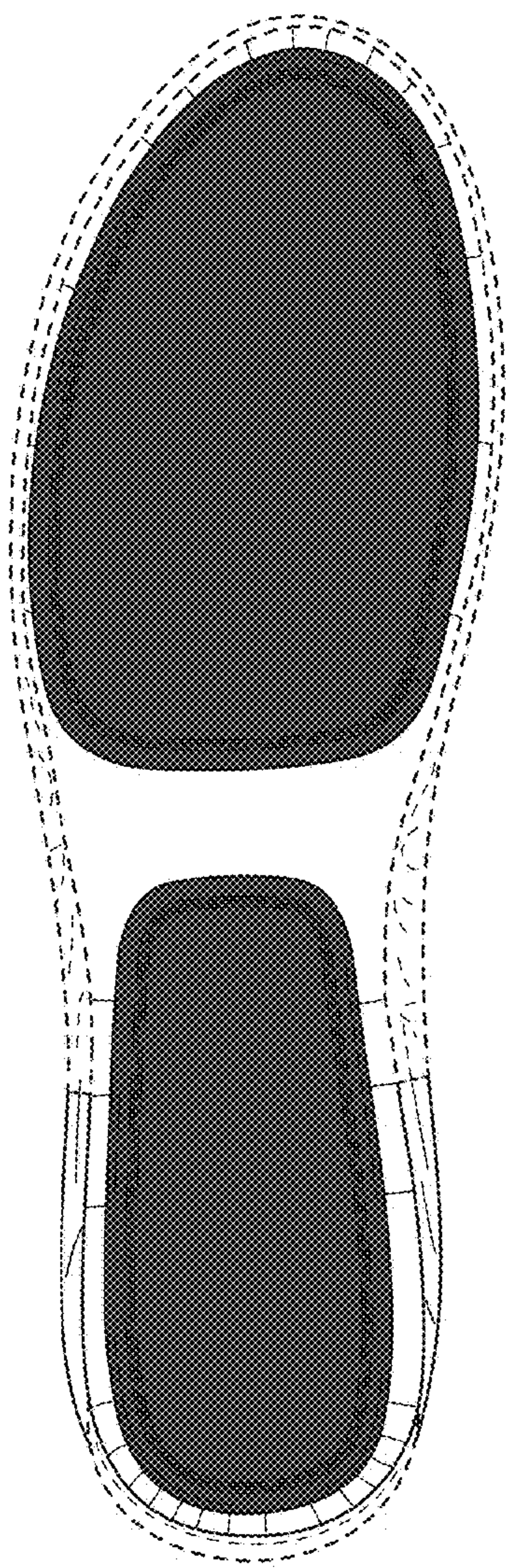

FIG. 12

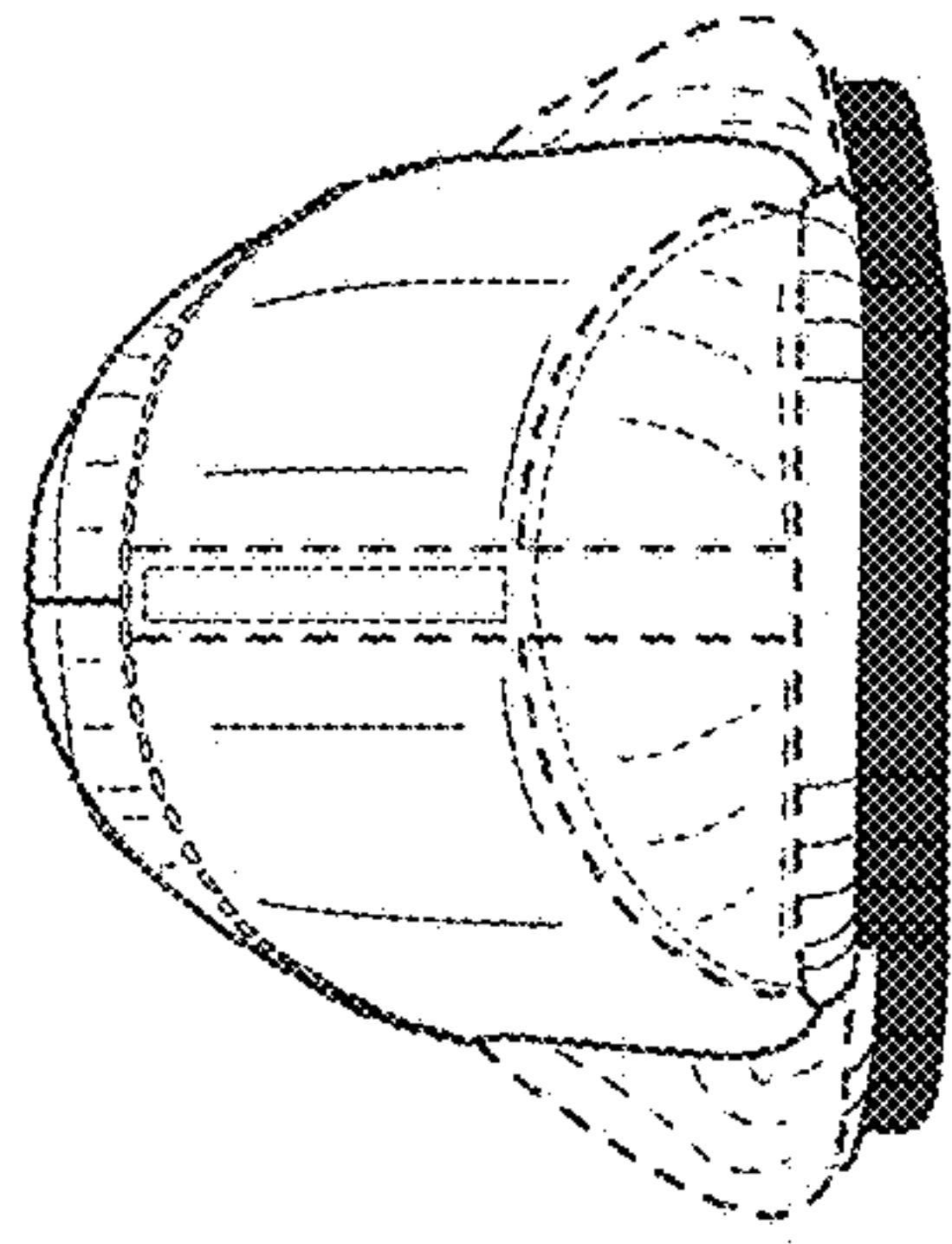

FIG. 14

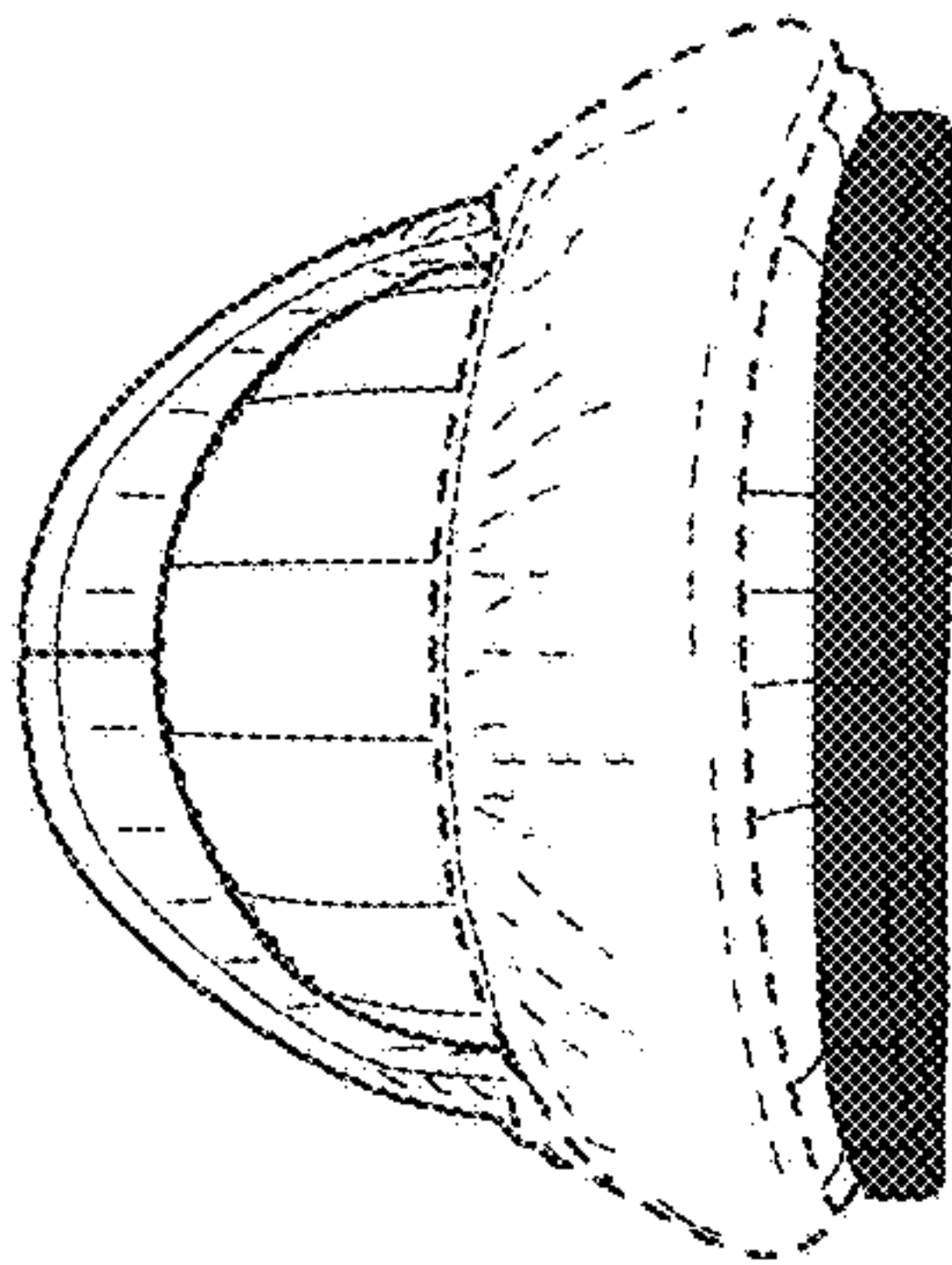

FIG. 13

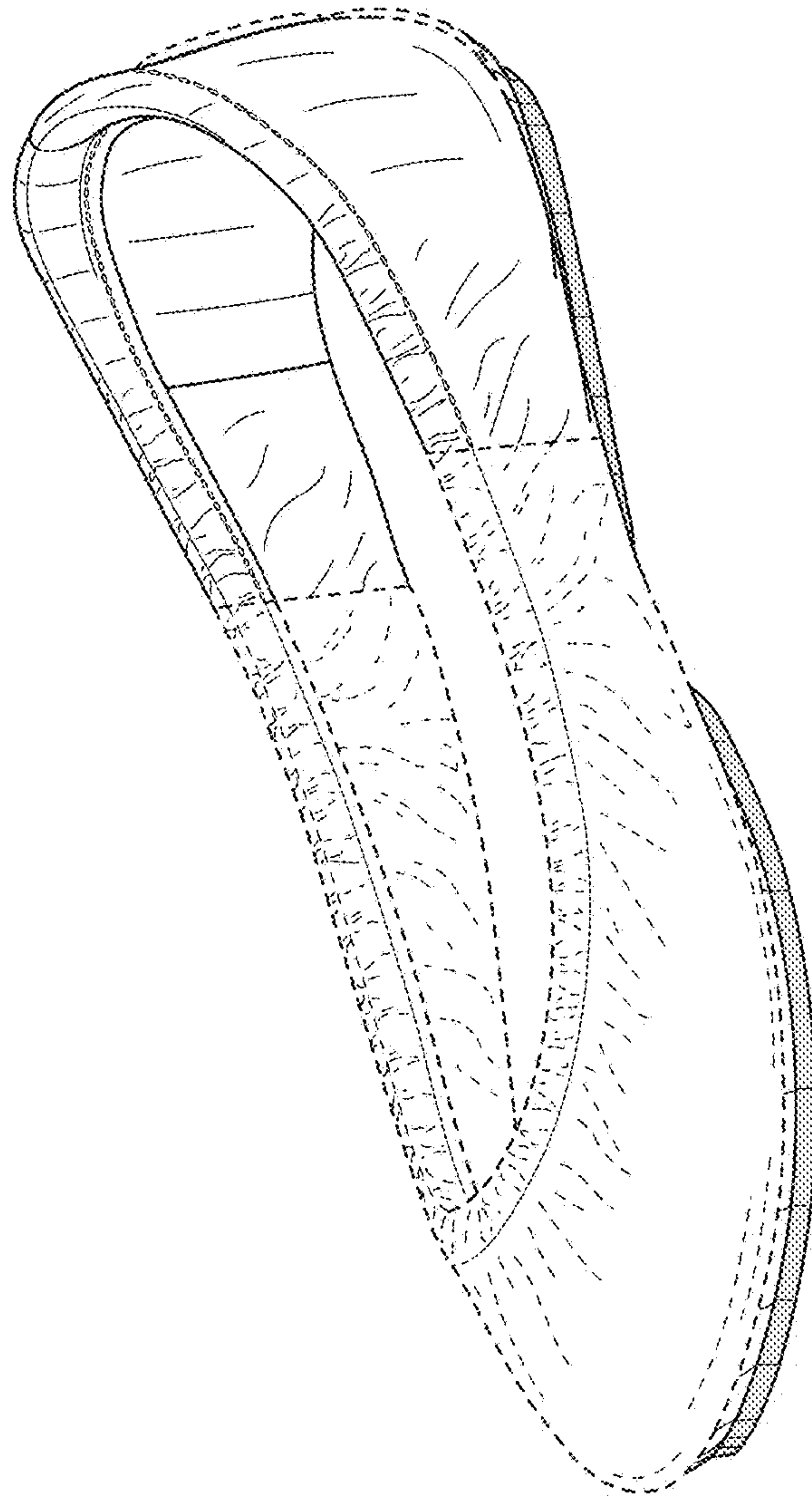

FIG. 15

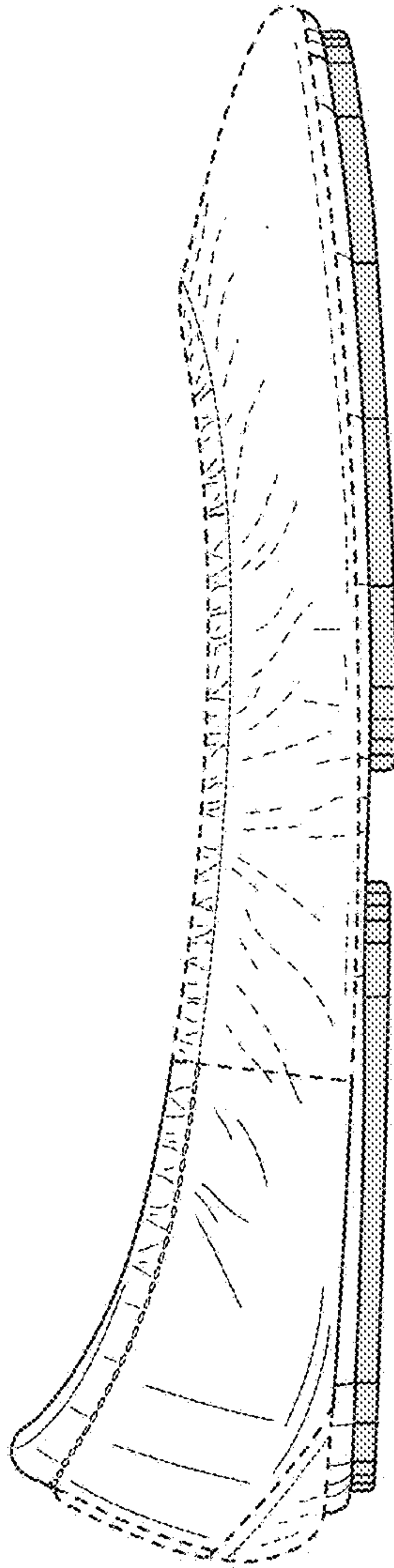

FIG. 16

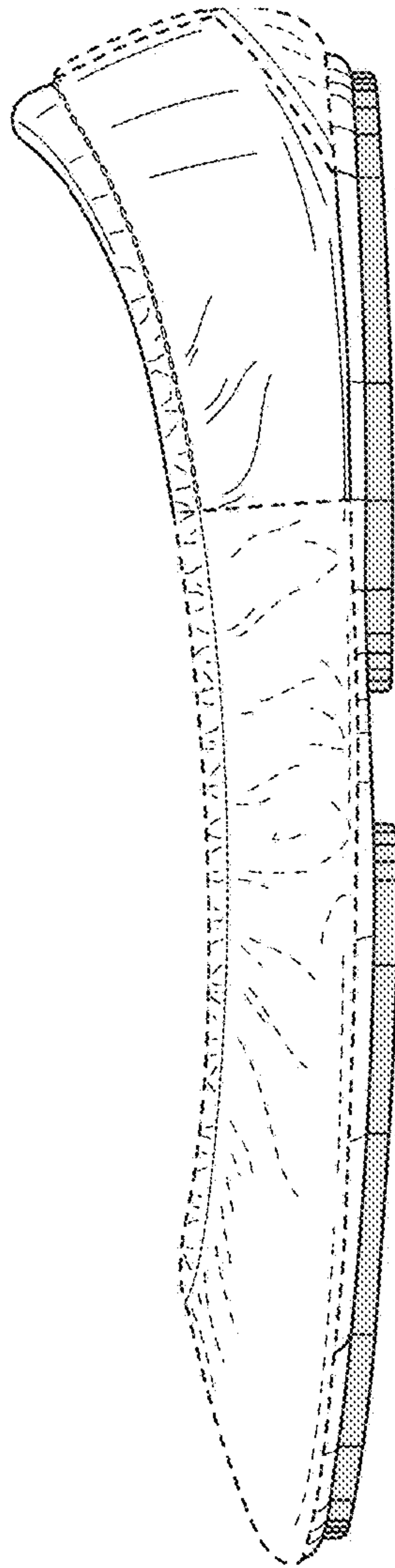

FIG. 17

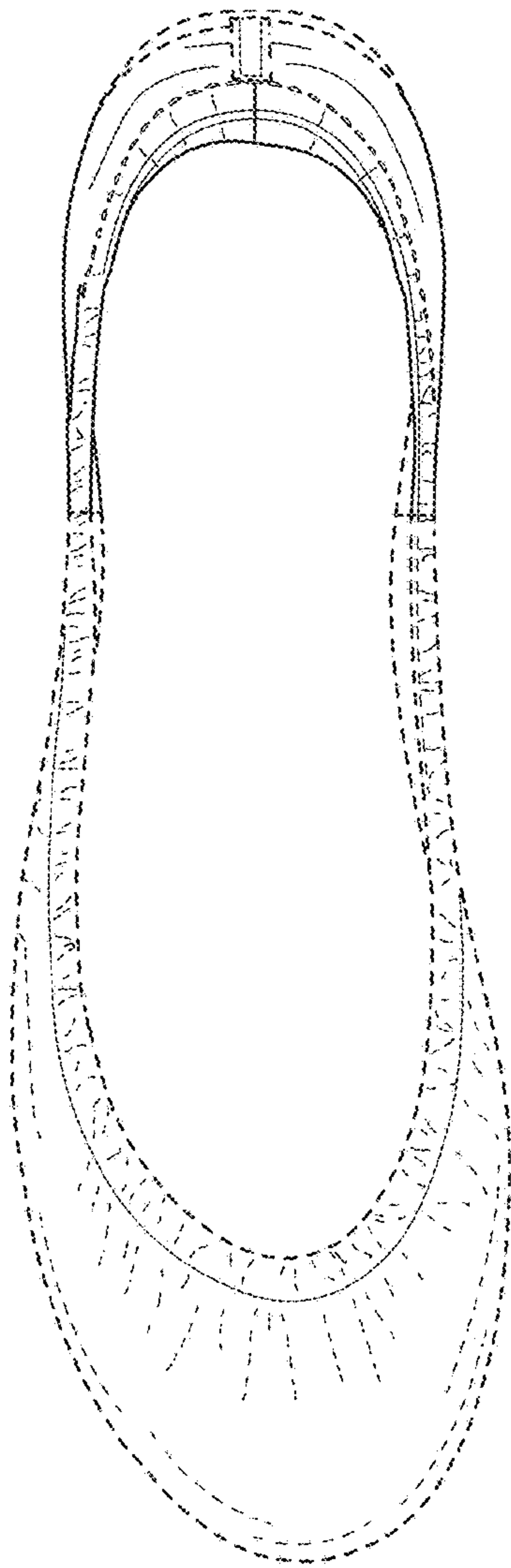

FIG. 18

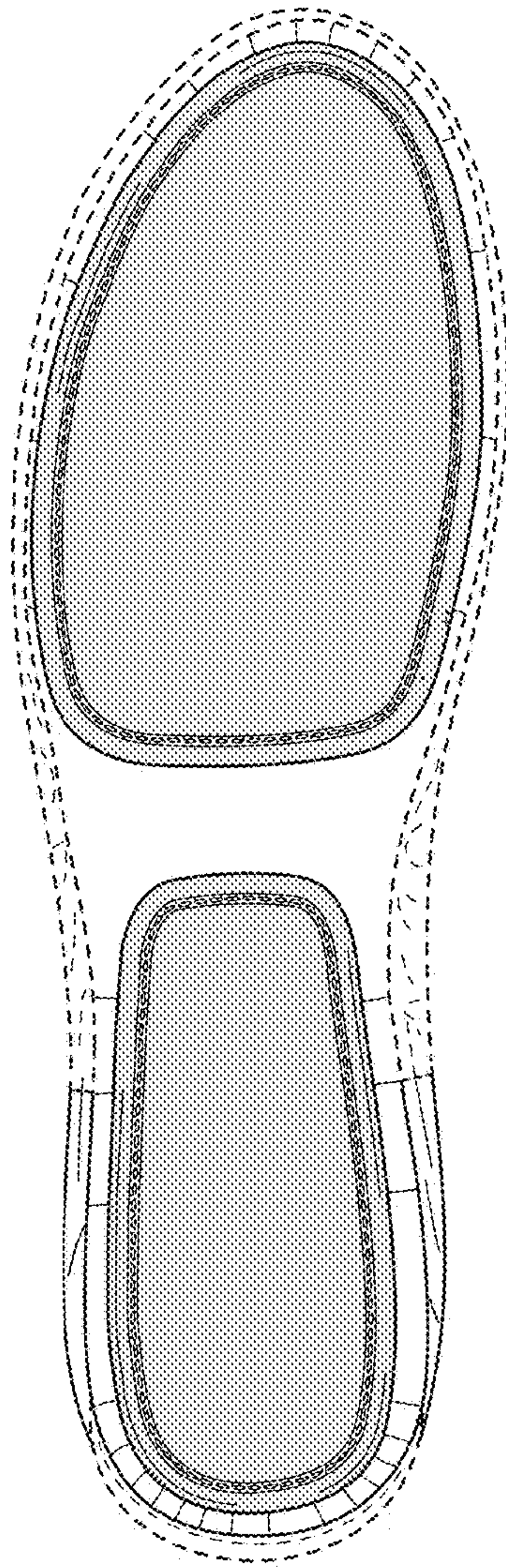

FIG. 19

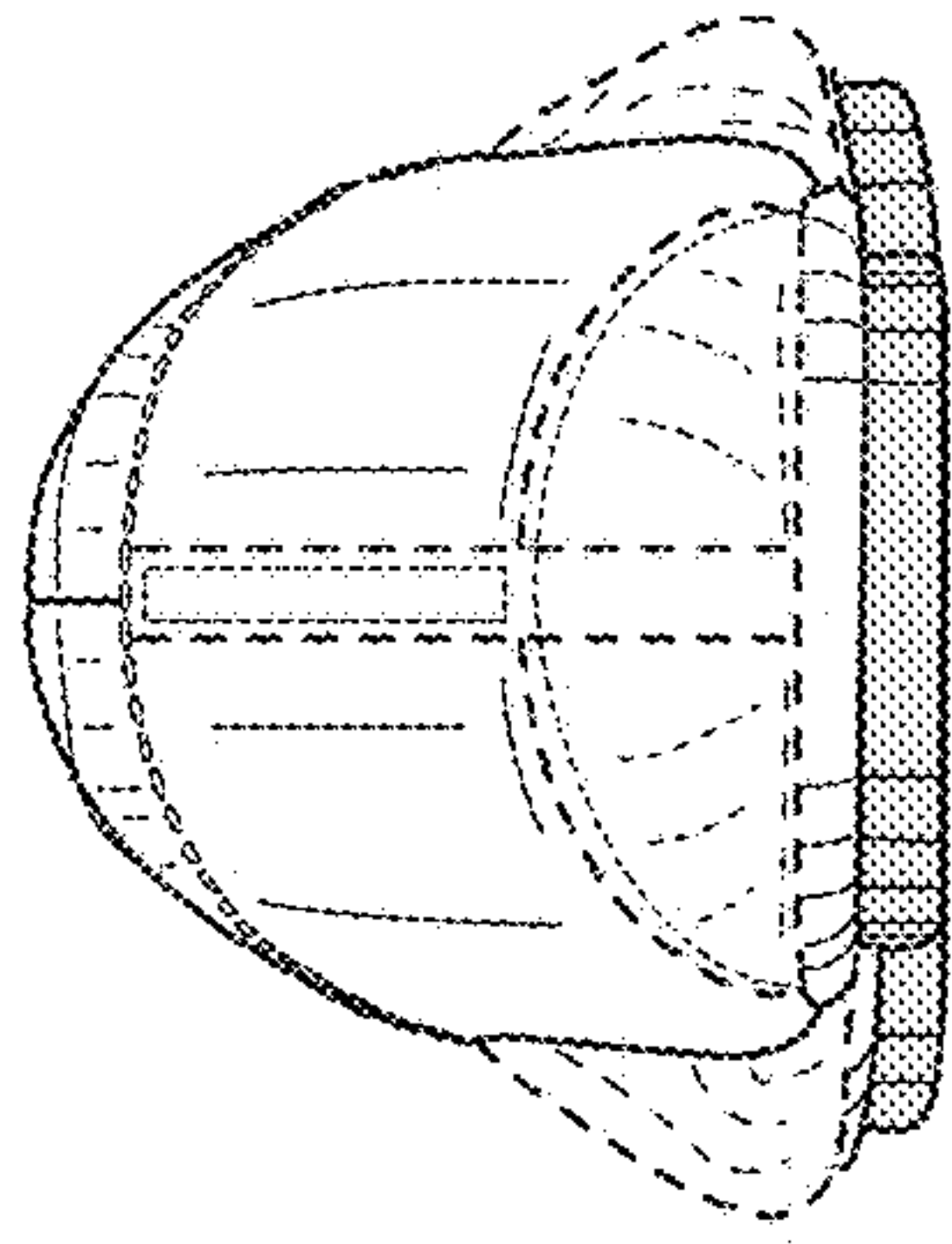

FIG. 20

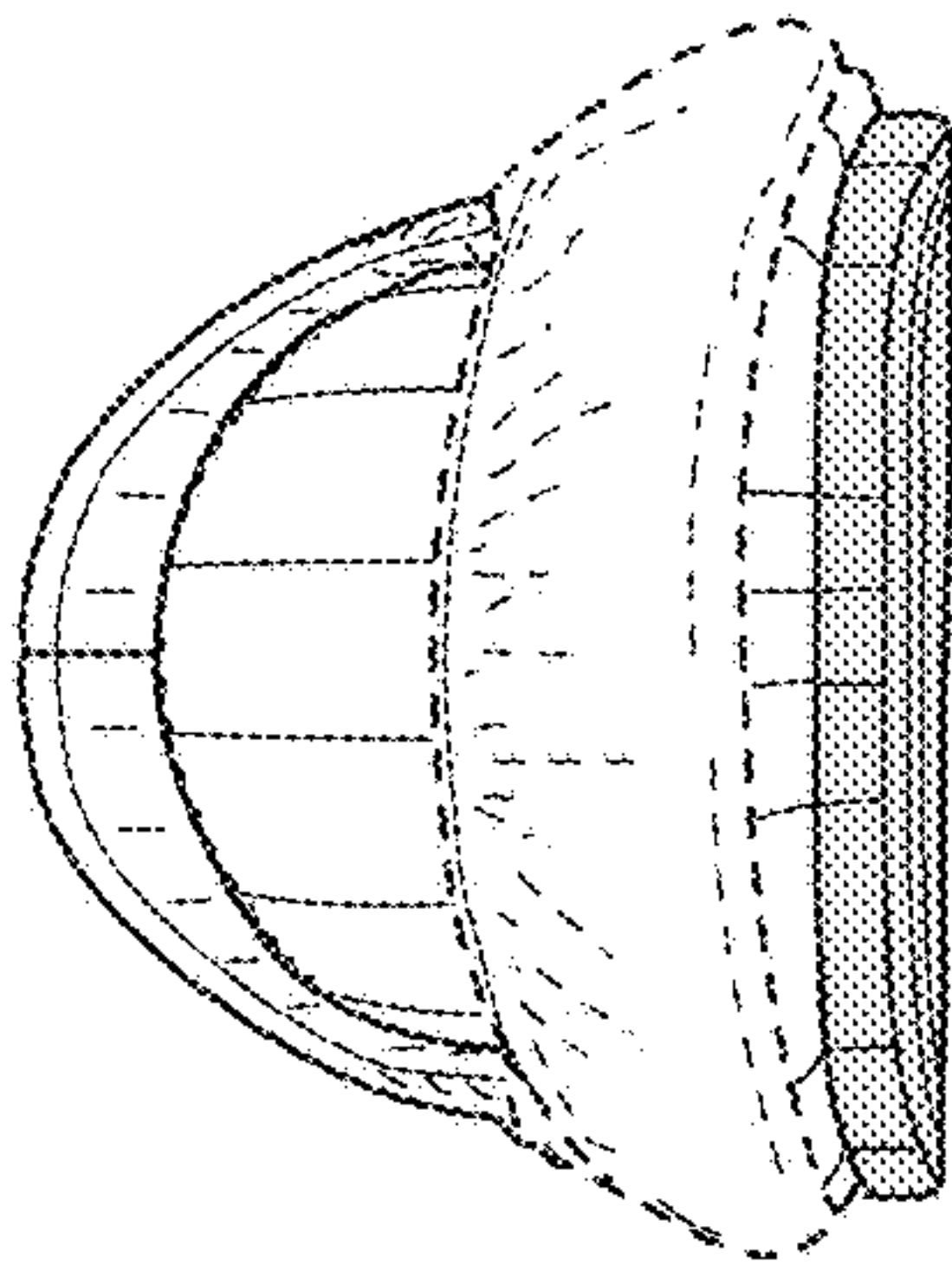

FIG. 21

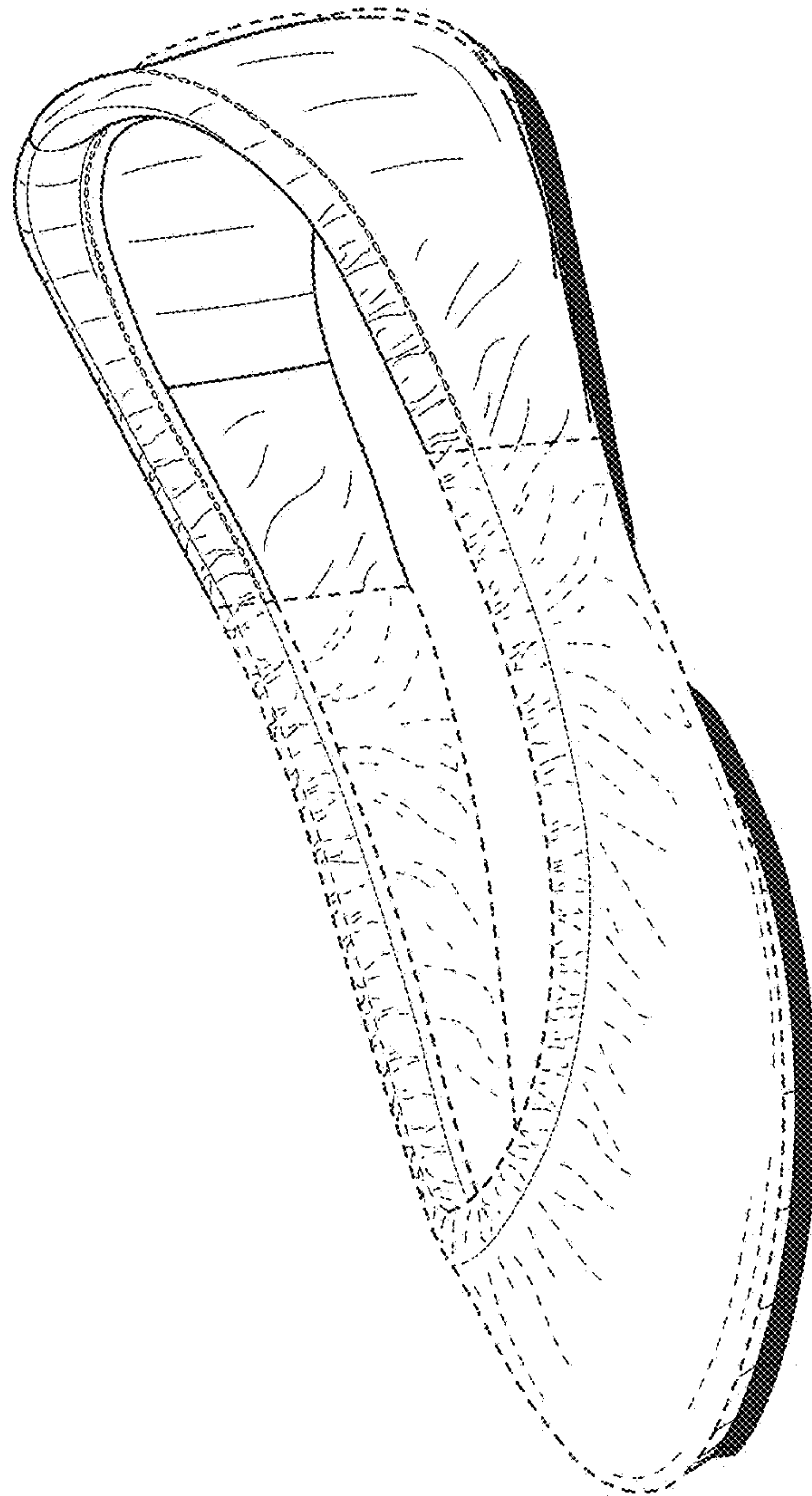

FIG. 22

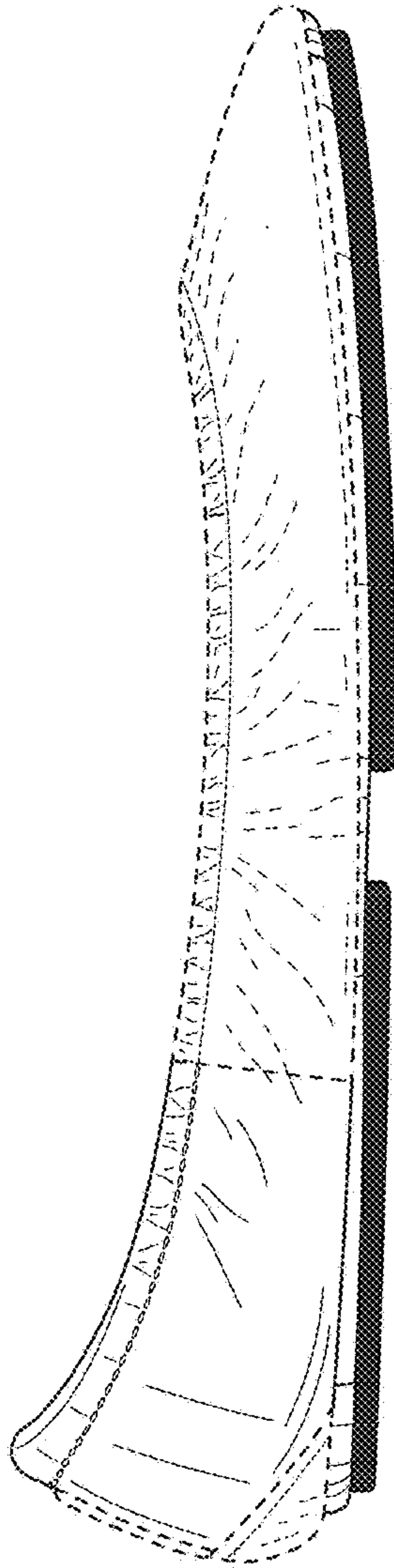

FIG. 23

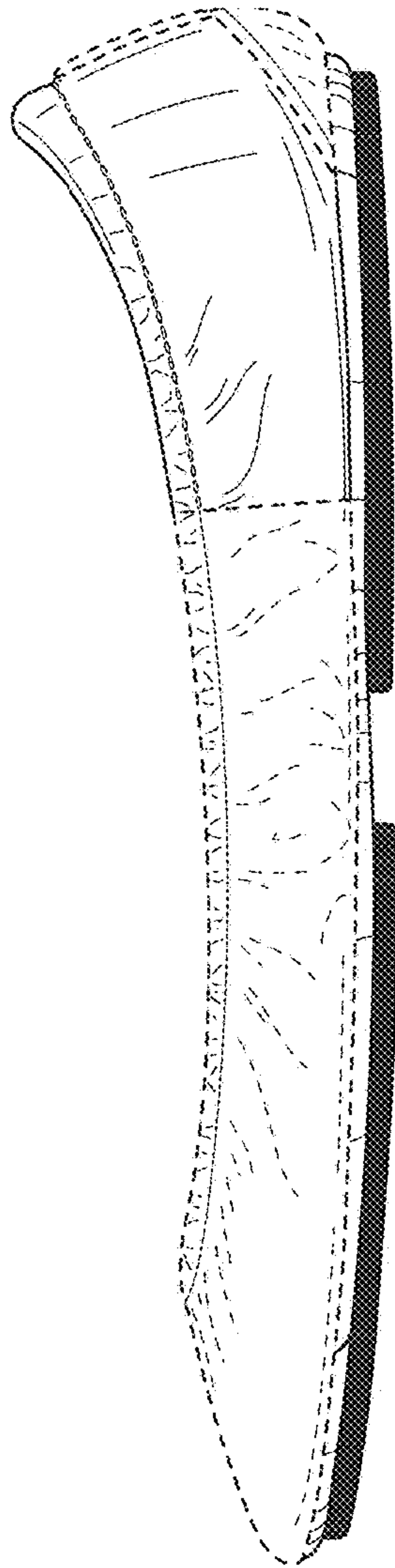

FIG. 24

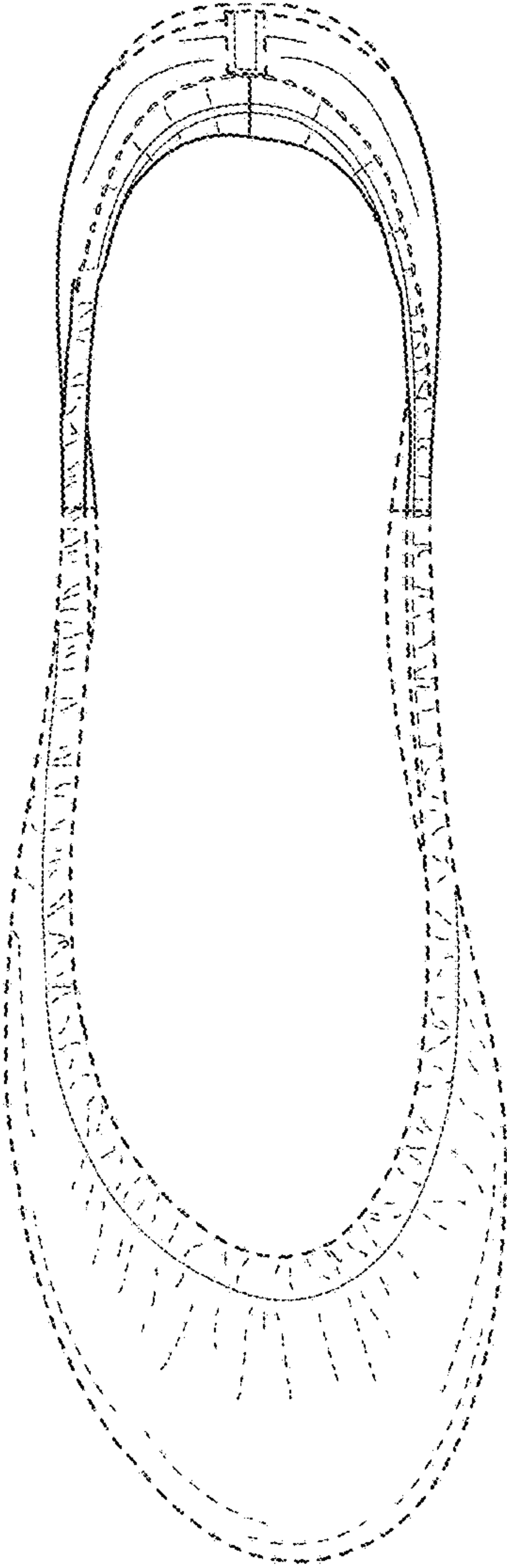

FIG. 25

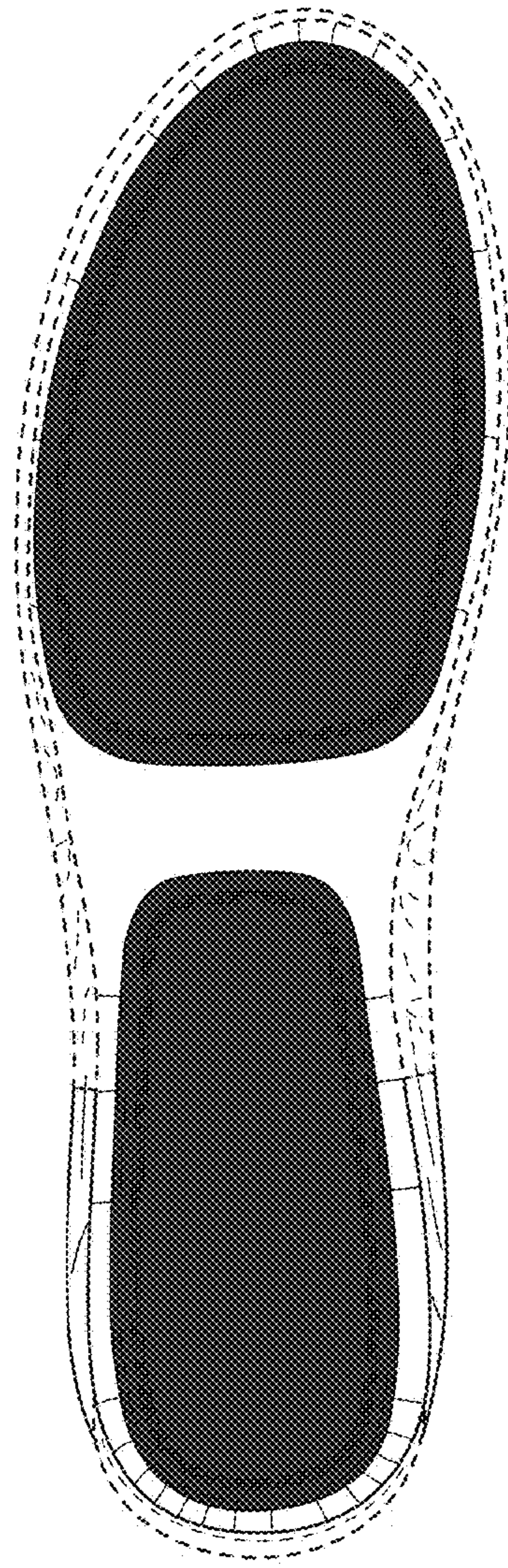

FIG. 26

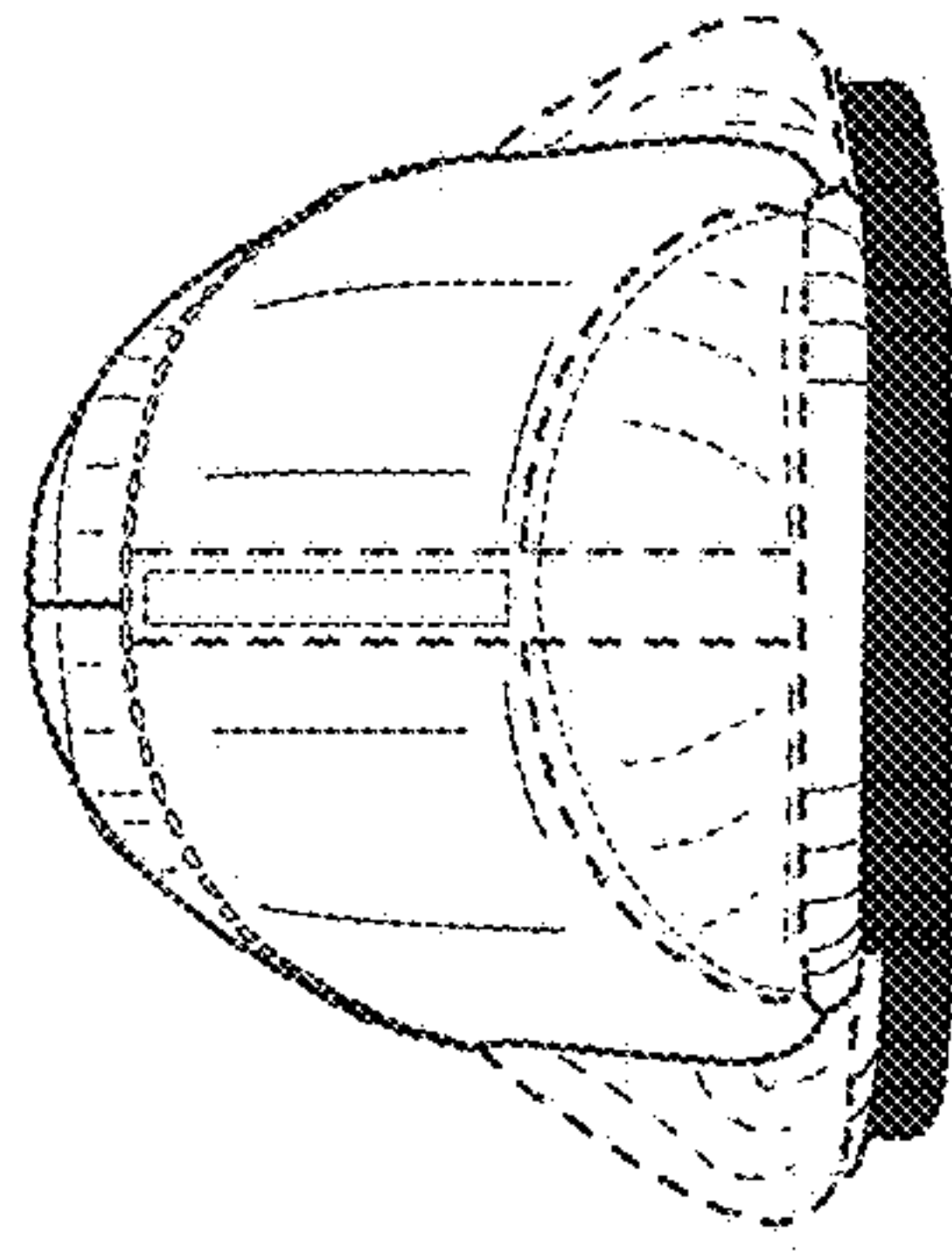

FIG. 27

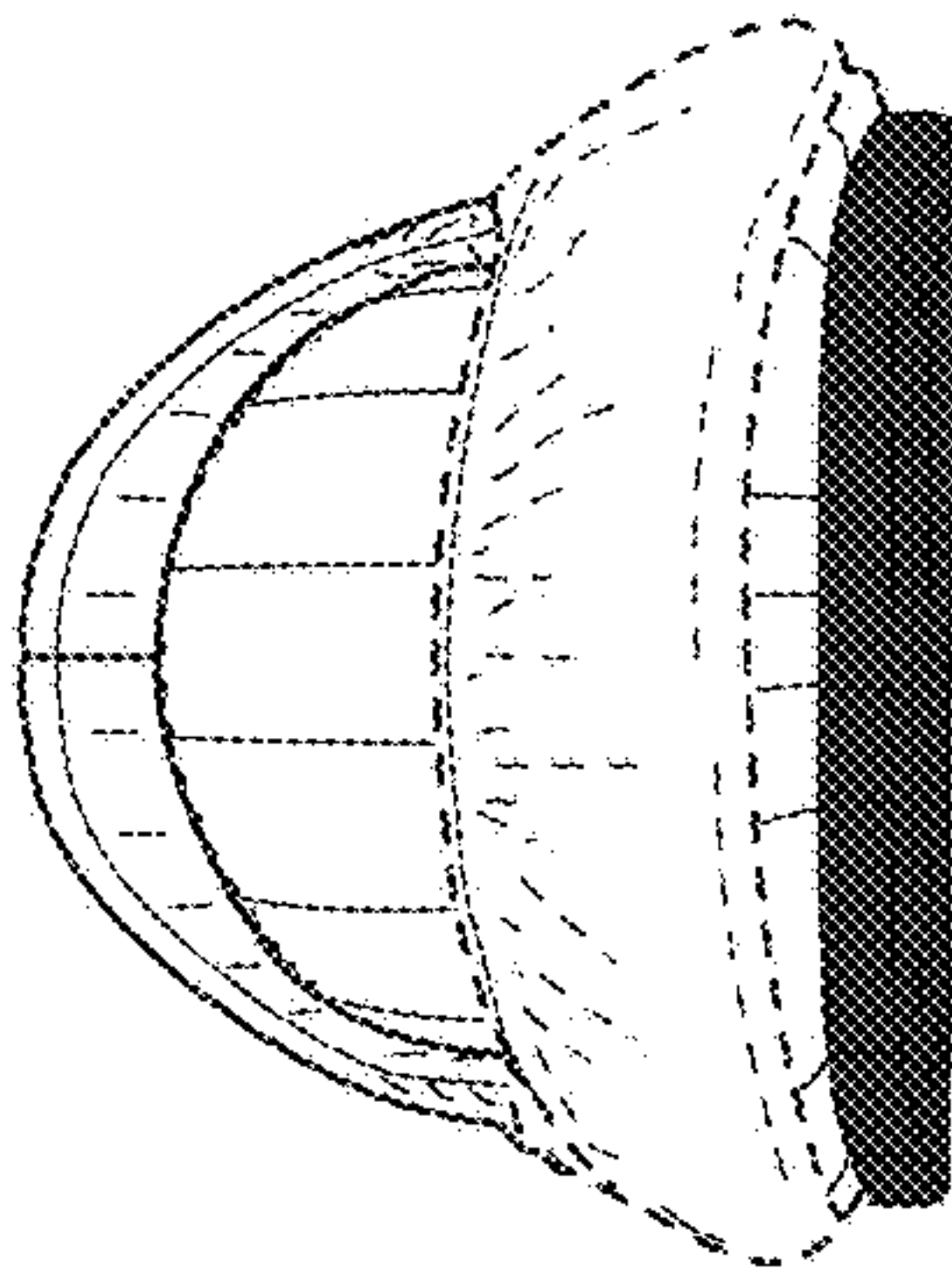

FIG. 28

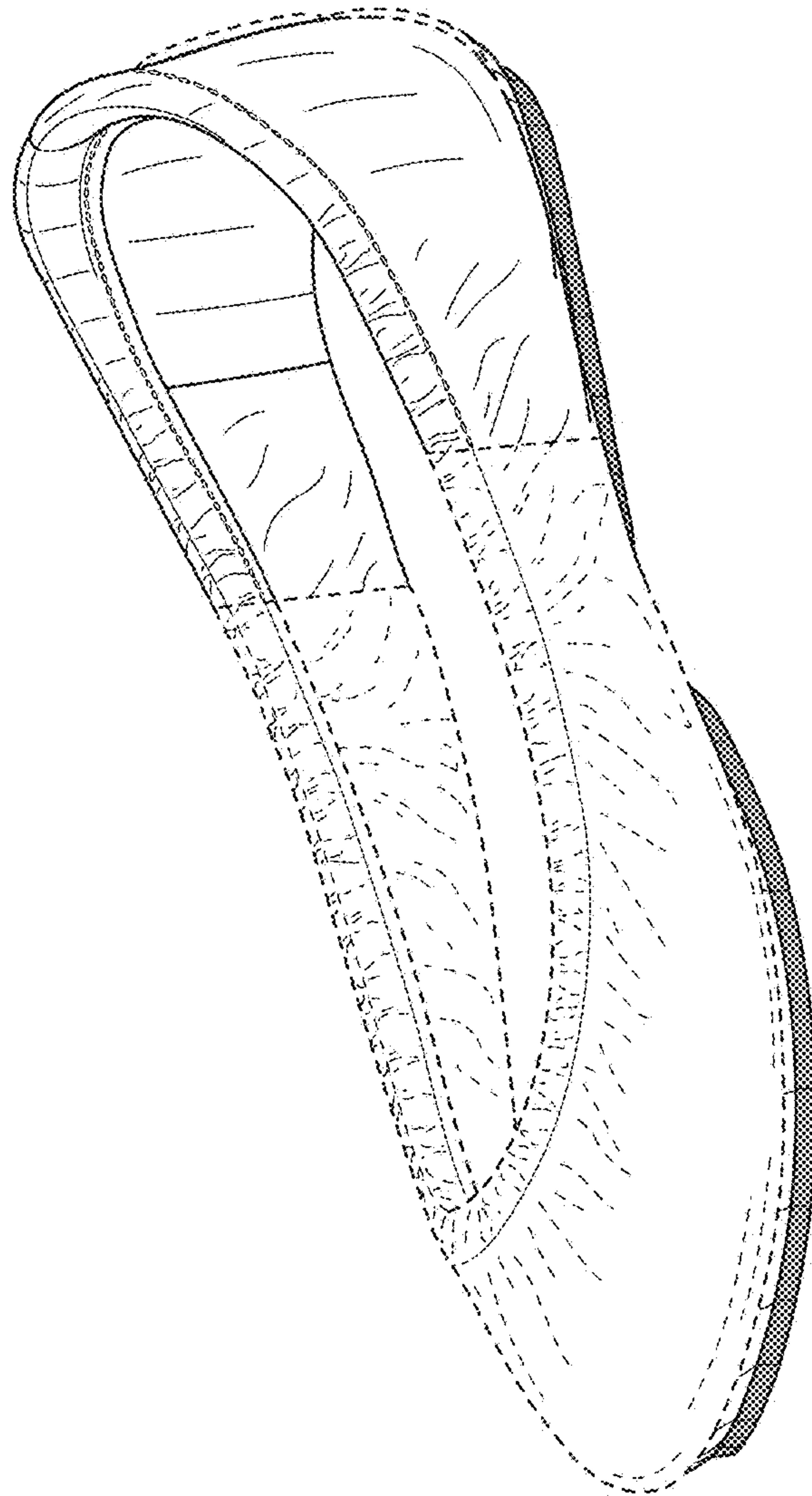

FIG. 29

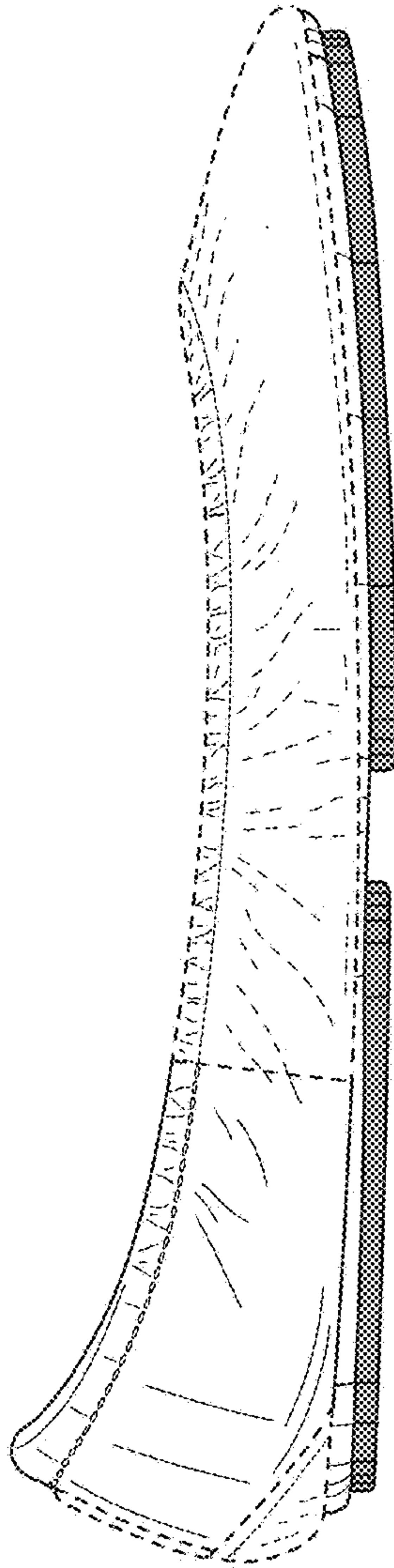

FIG. 30

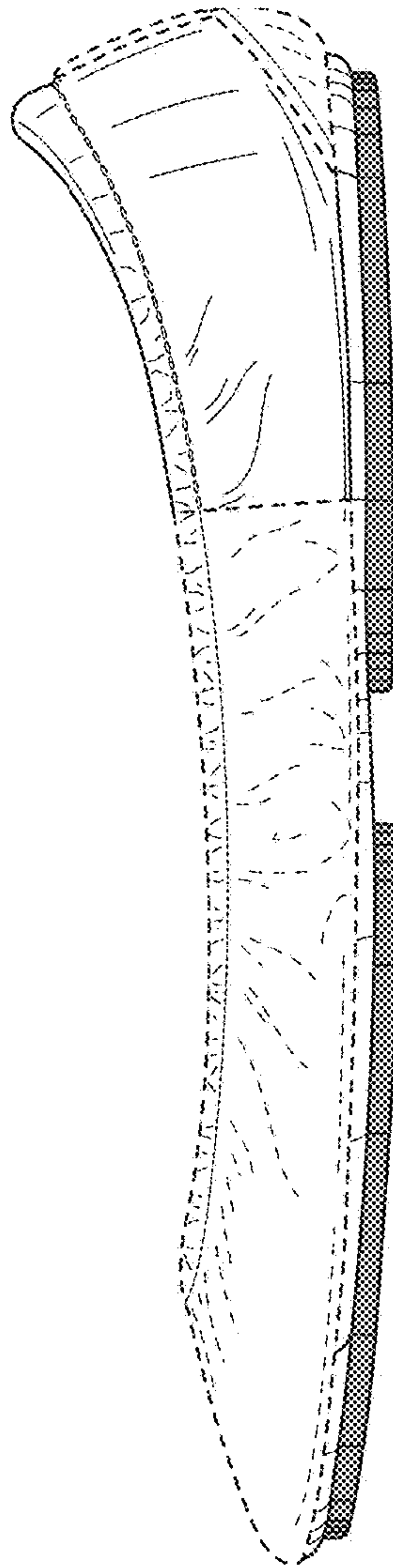

FIG. 31

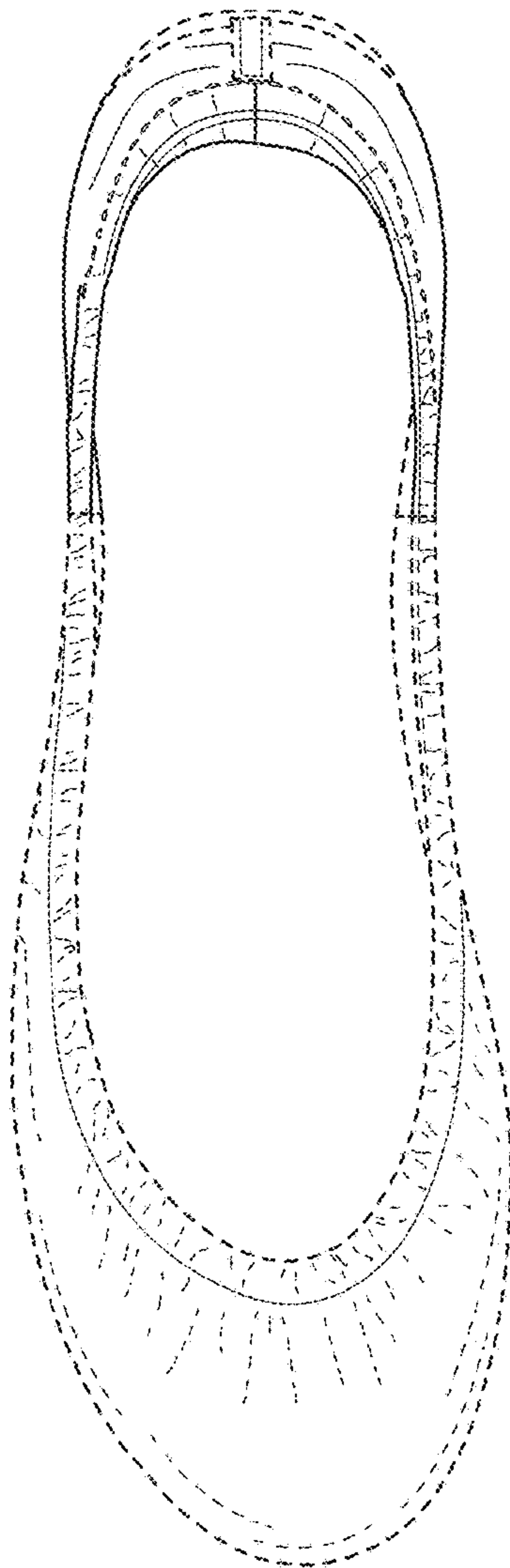

FIG. 32

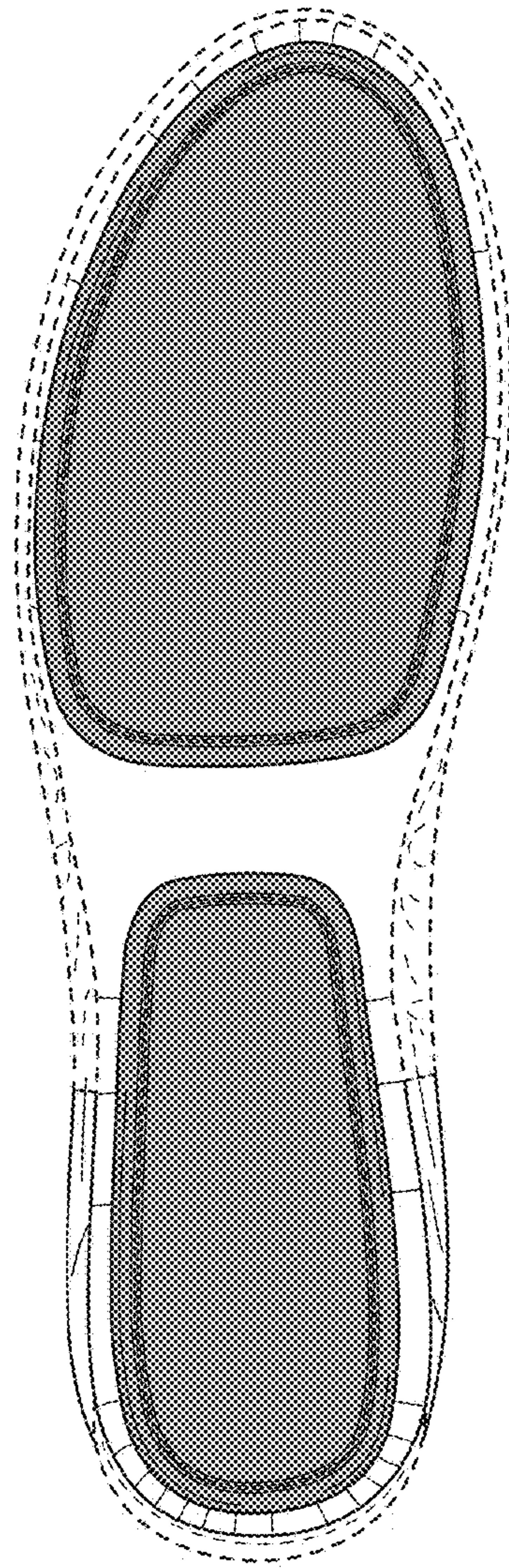

FIG. 33

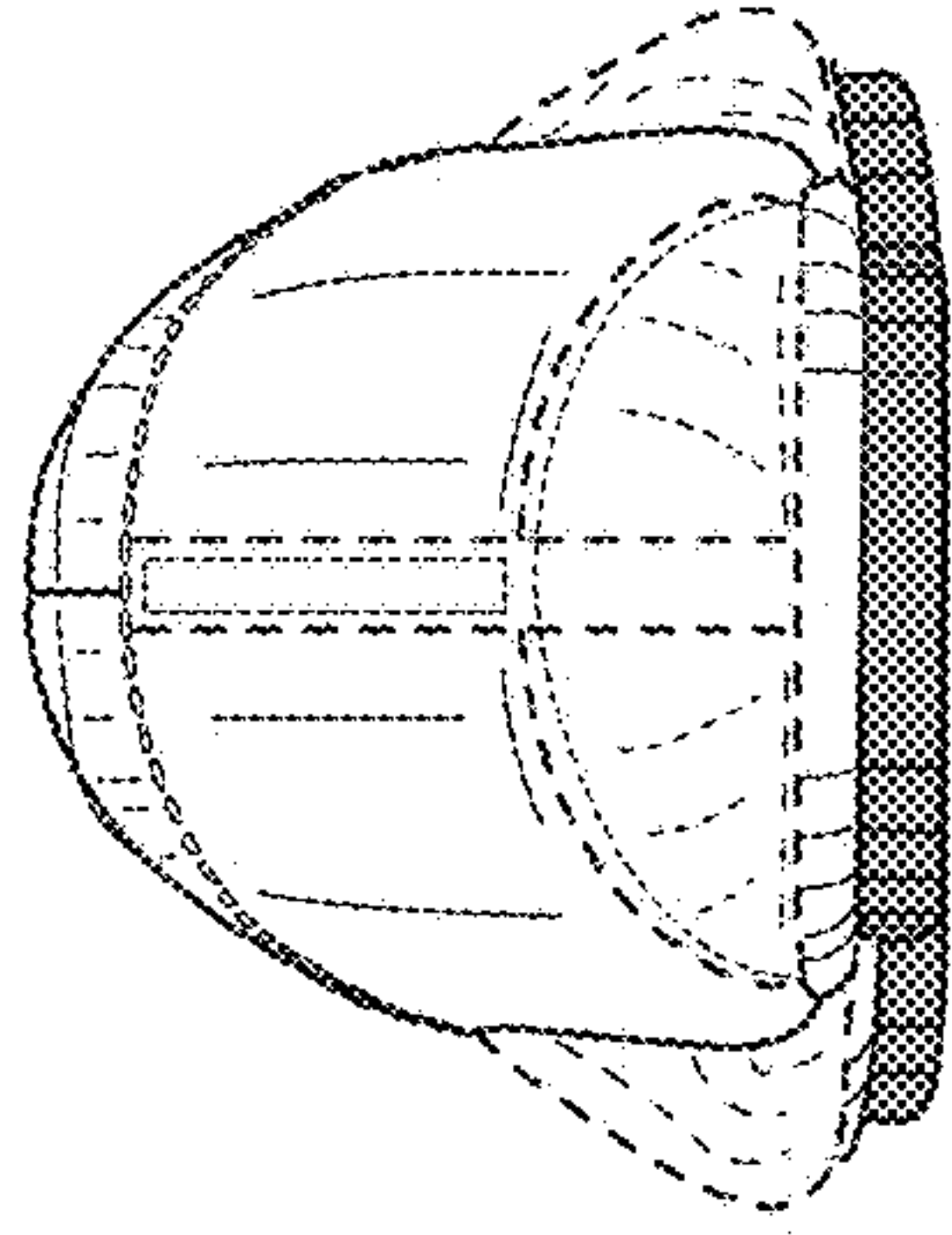

FIG. 34

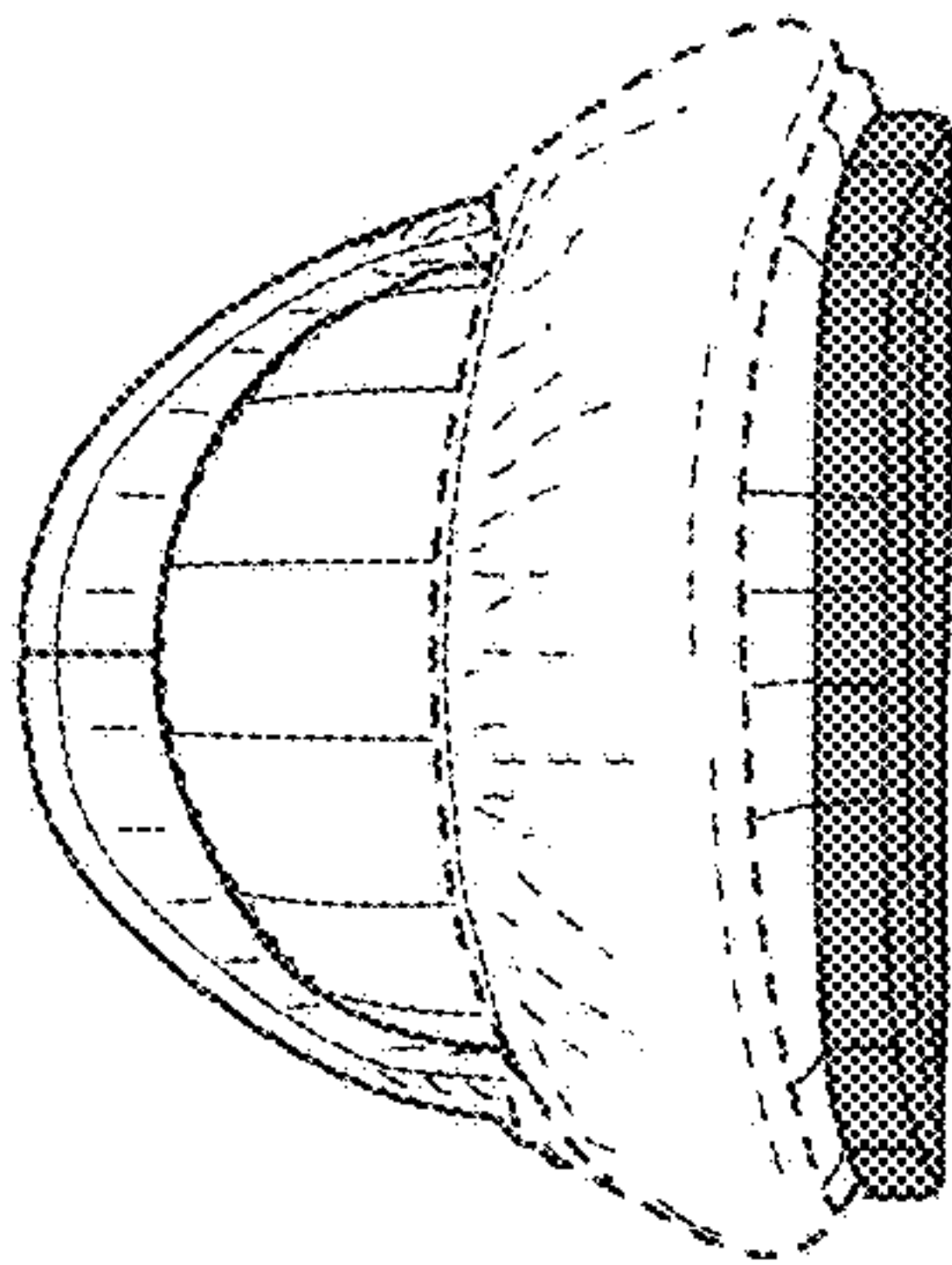

FIG. 35

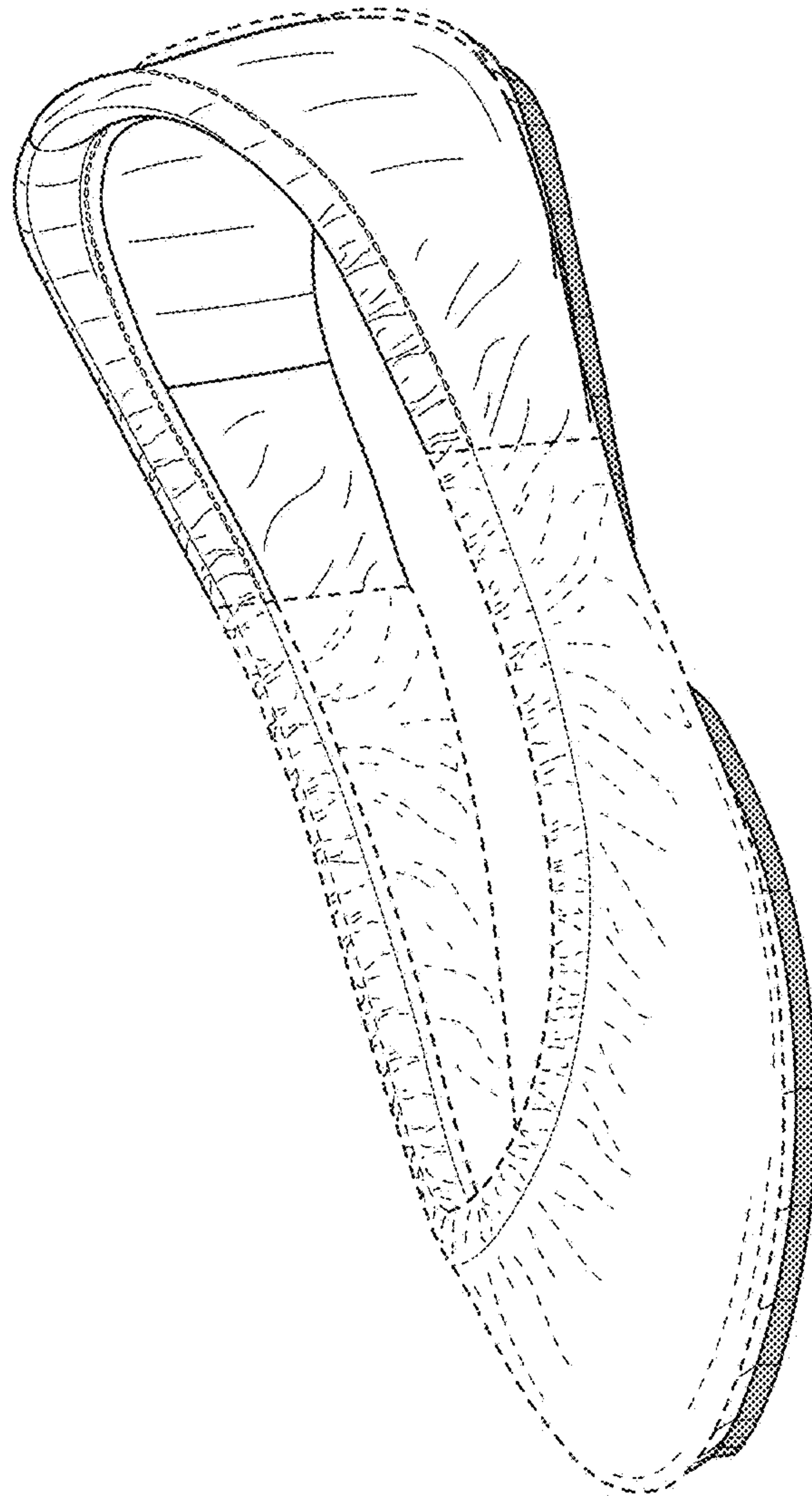

FIG. 36

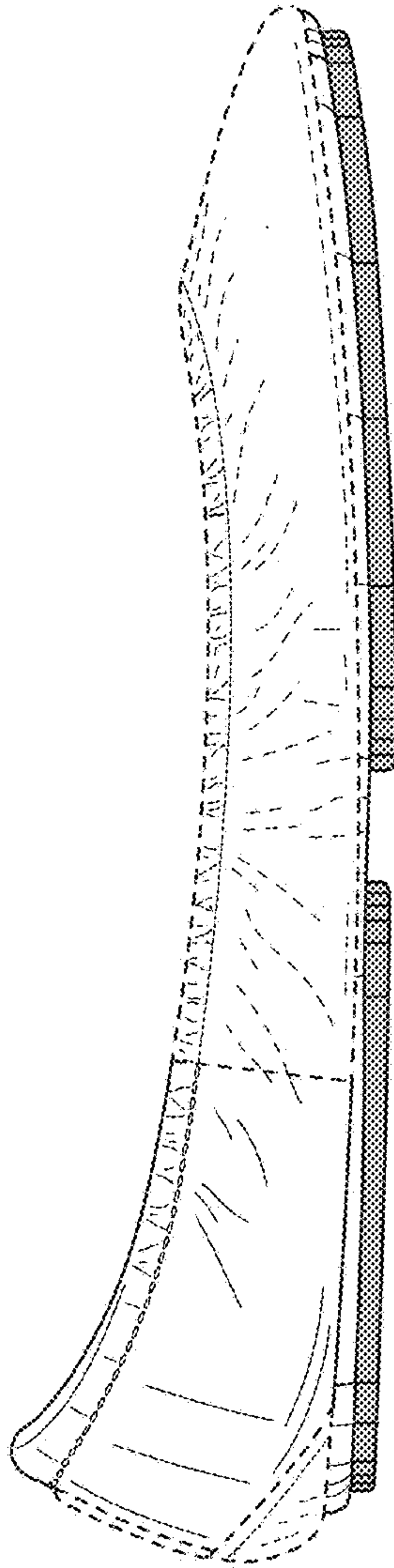

FIG. 37

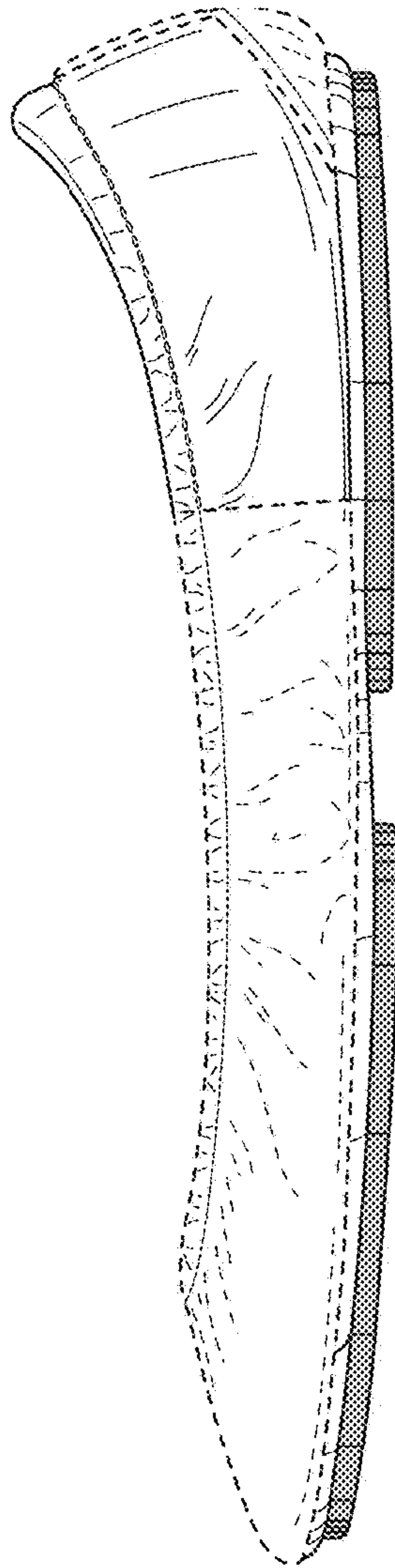

FIG. 38

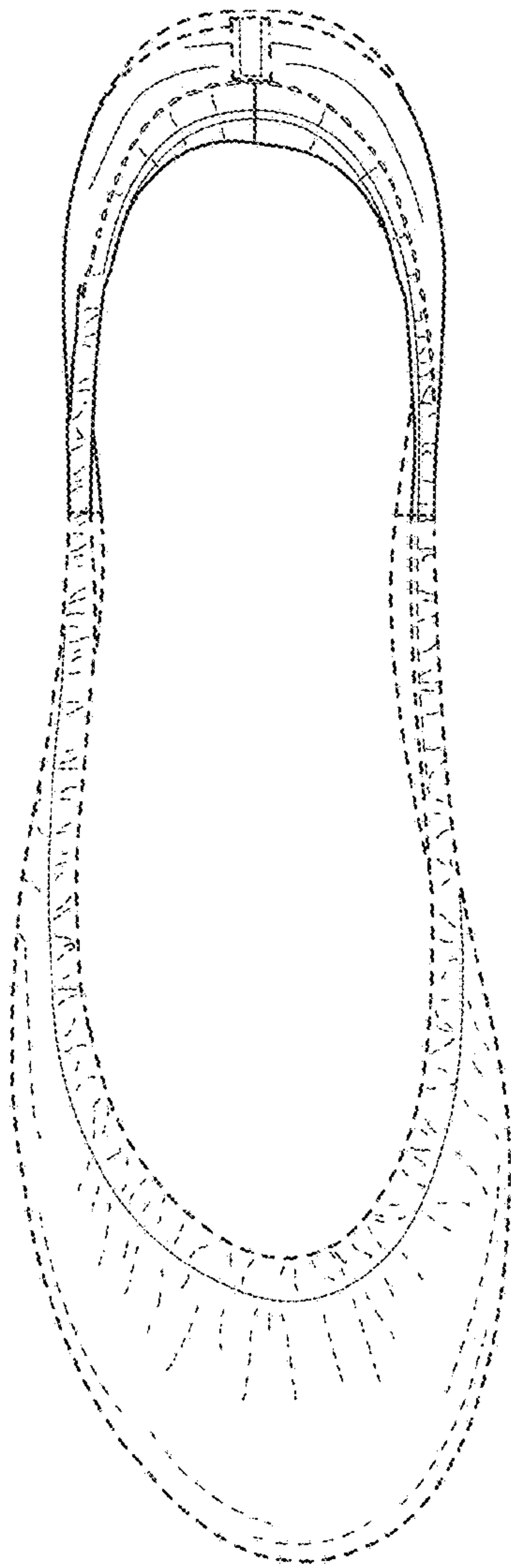

FIG. 39

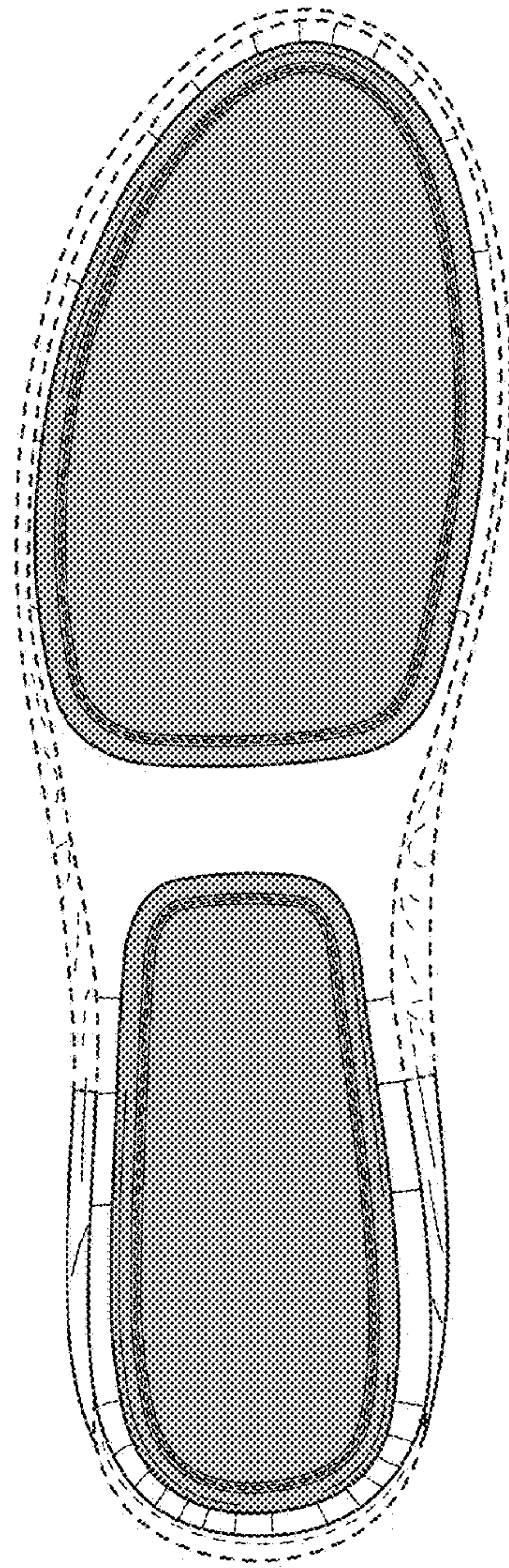

FIG. 40

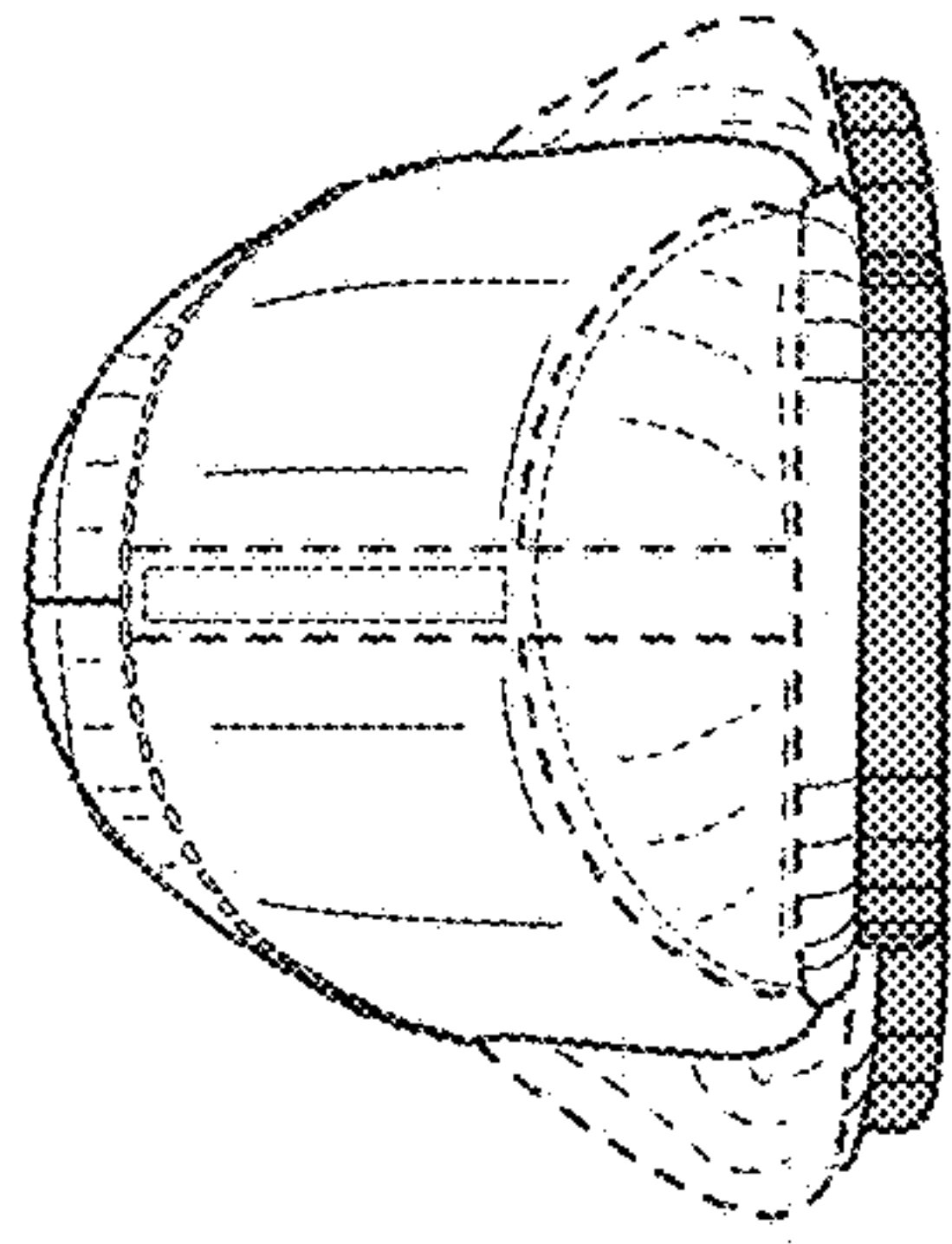

FIG. 41

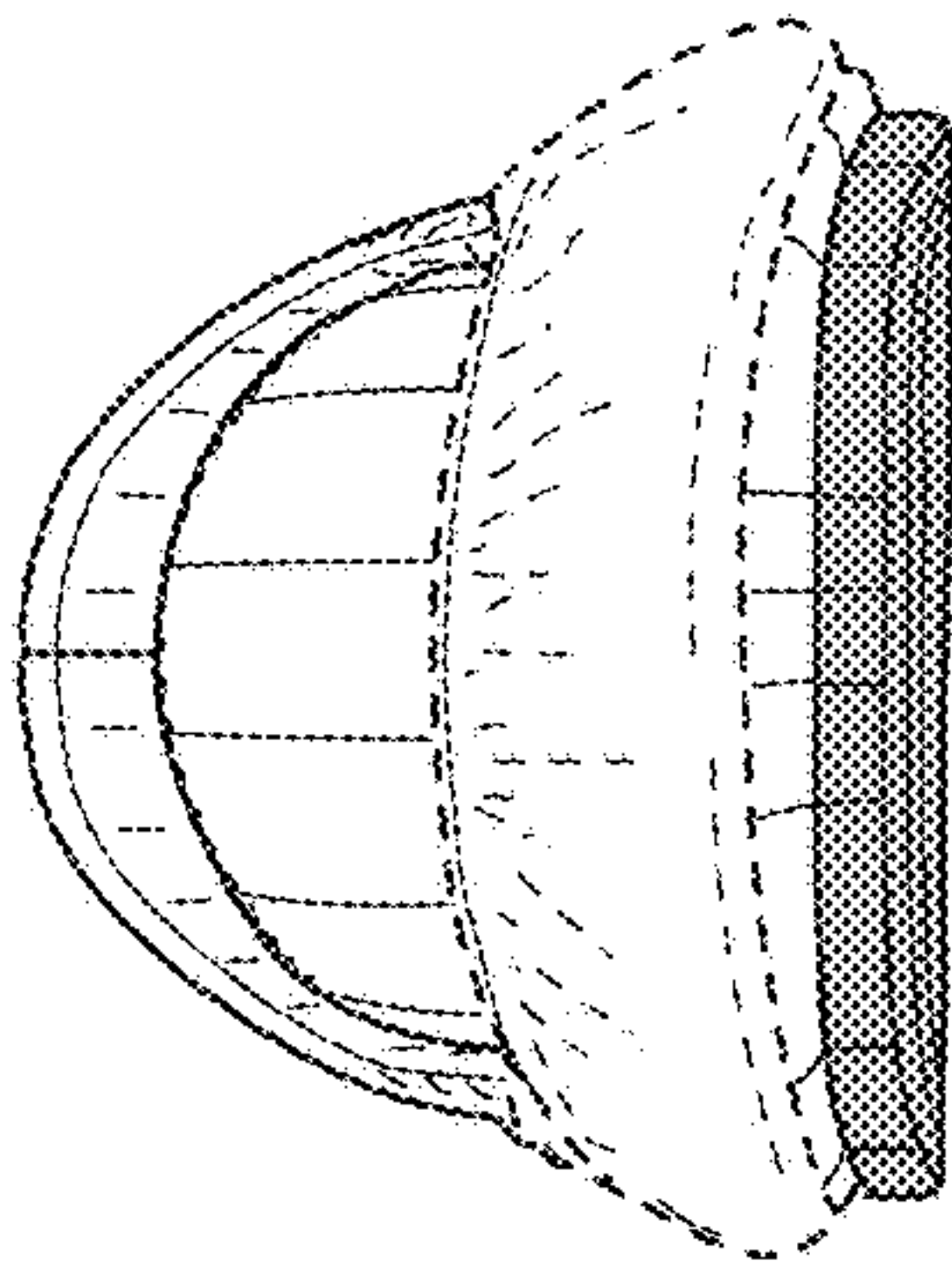

FIG. 42

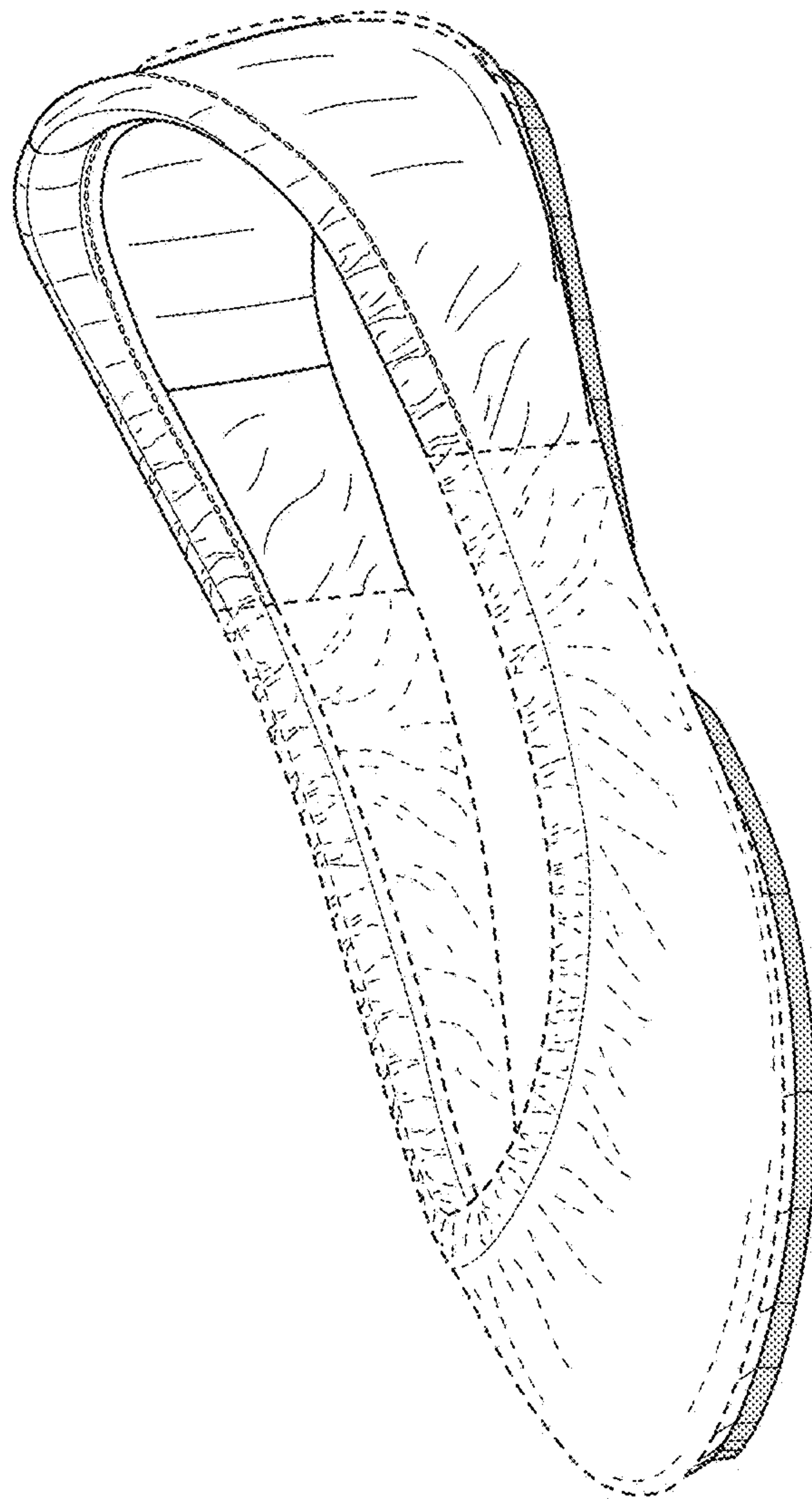

FIG. 43

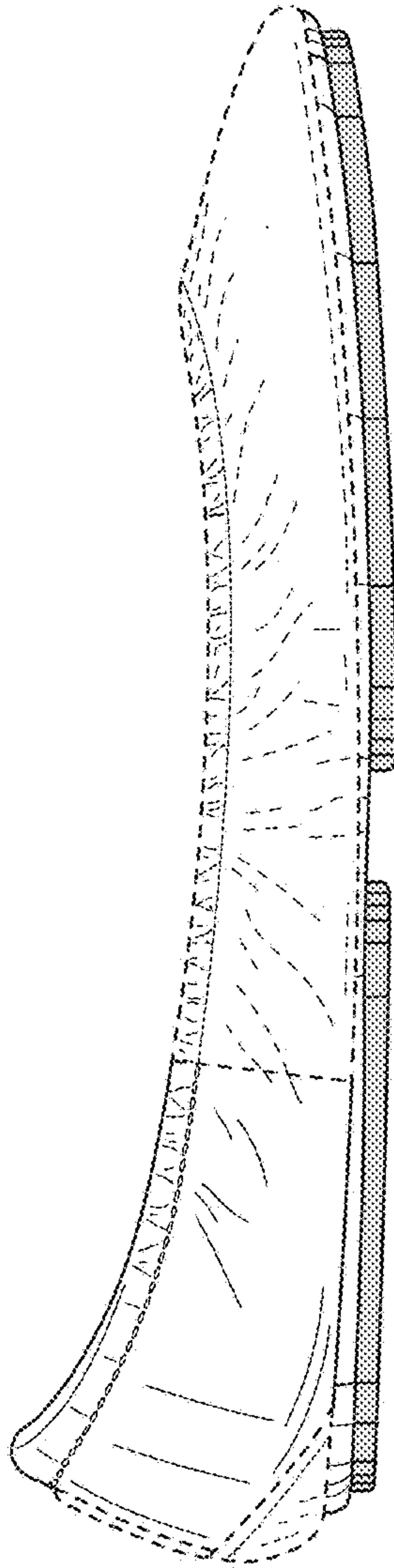

FIG. 44

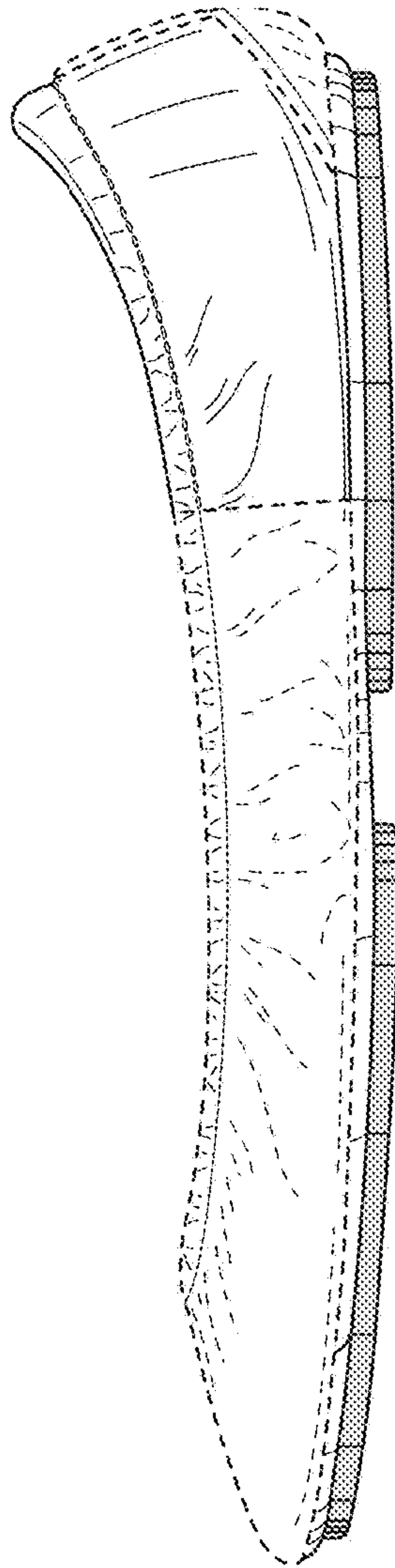

FIG. 45

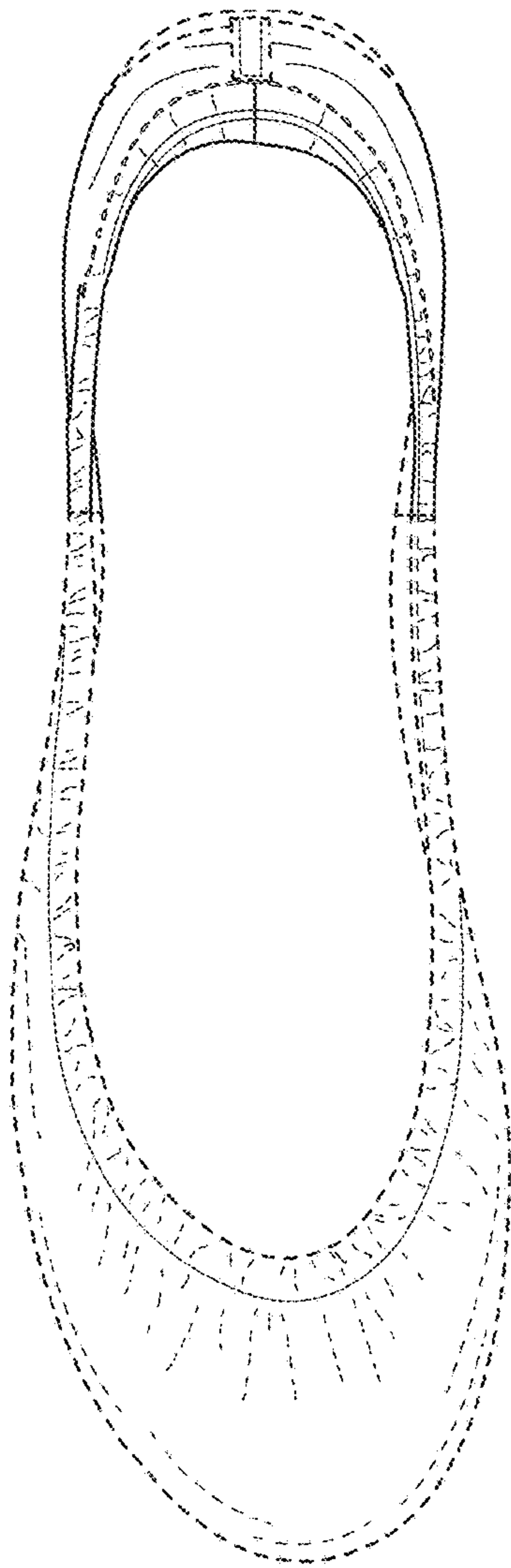

FIG. 46

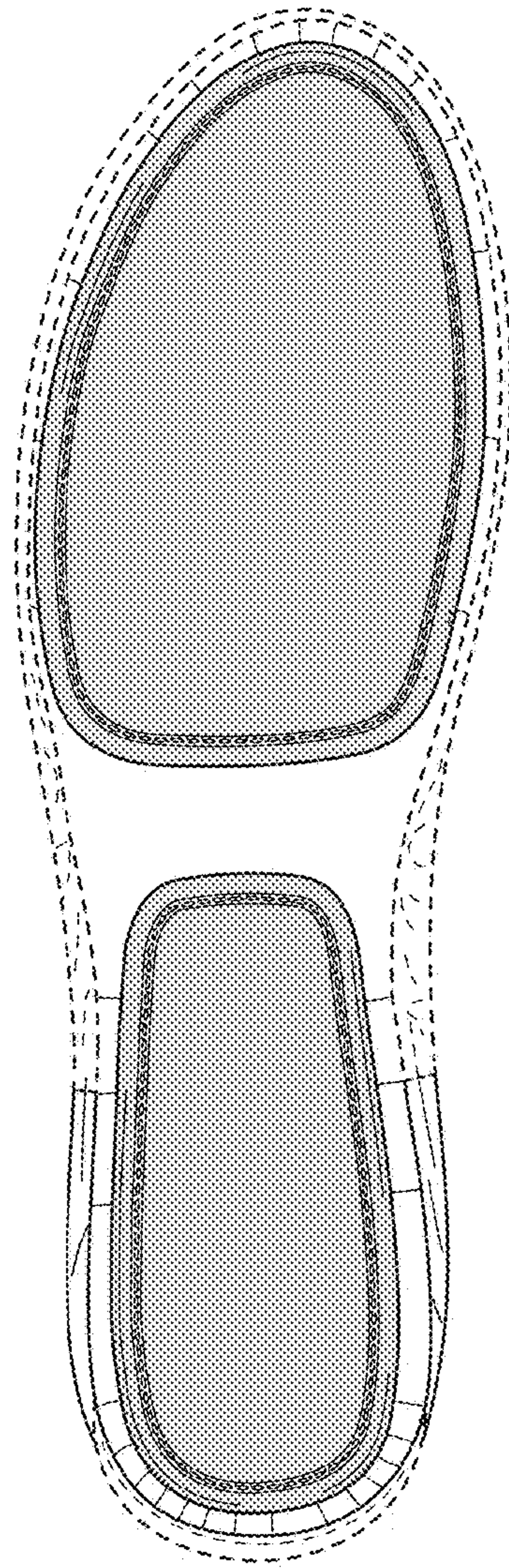

FIG. 47

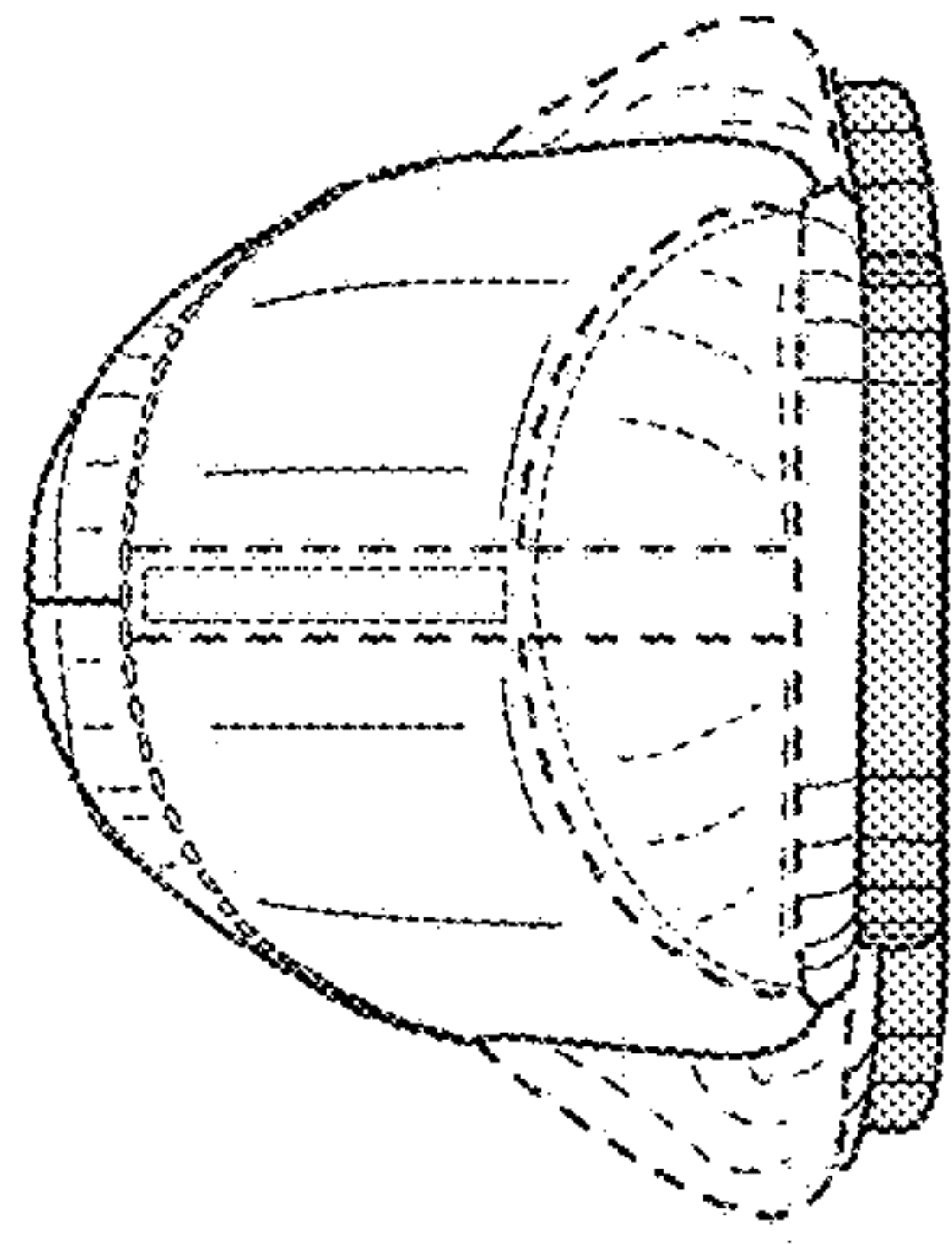

FIG. 49

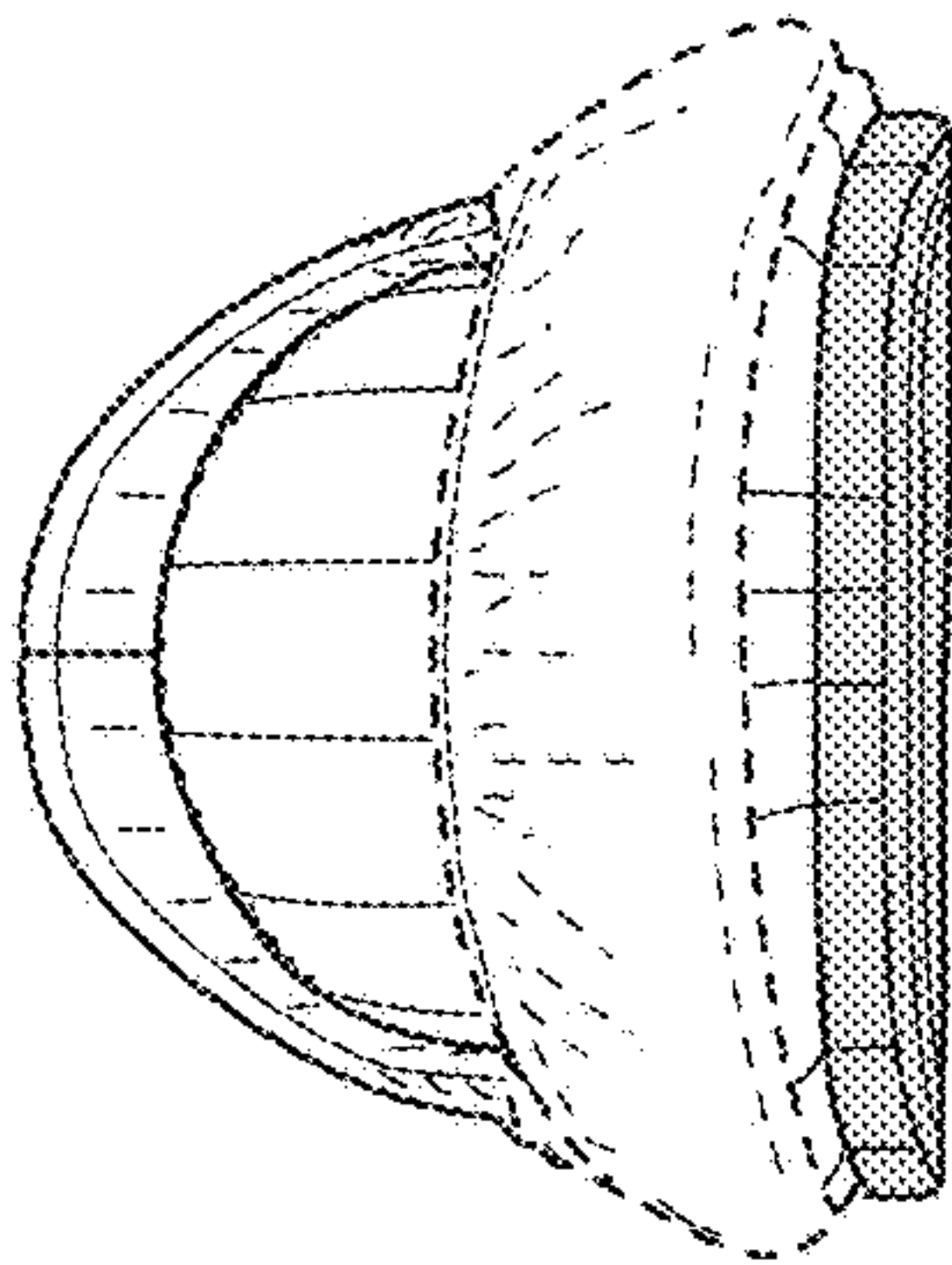

FIG. 48

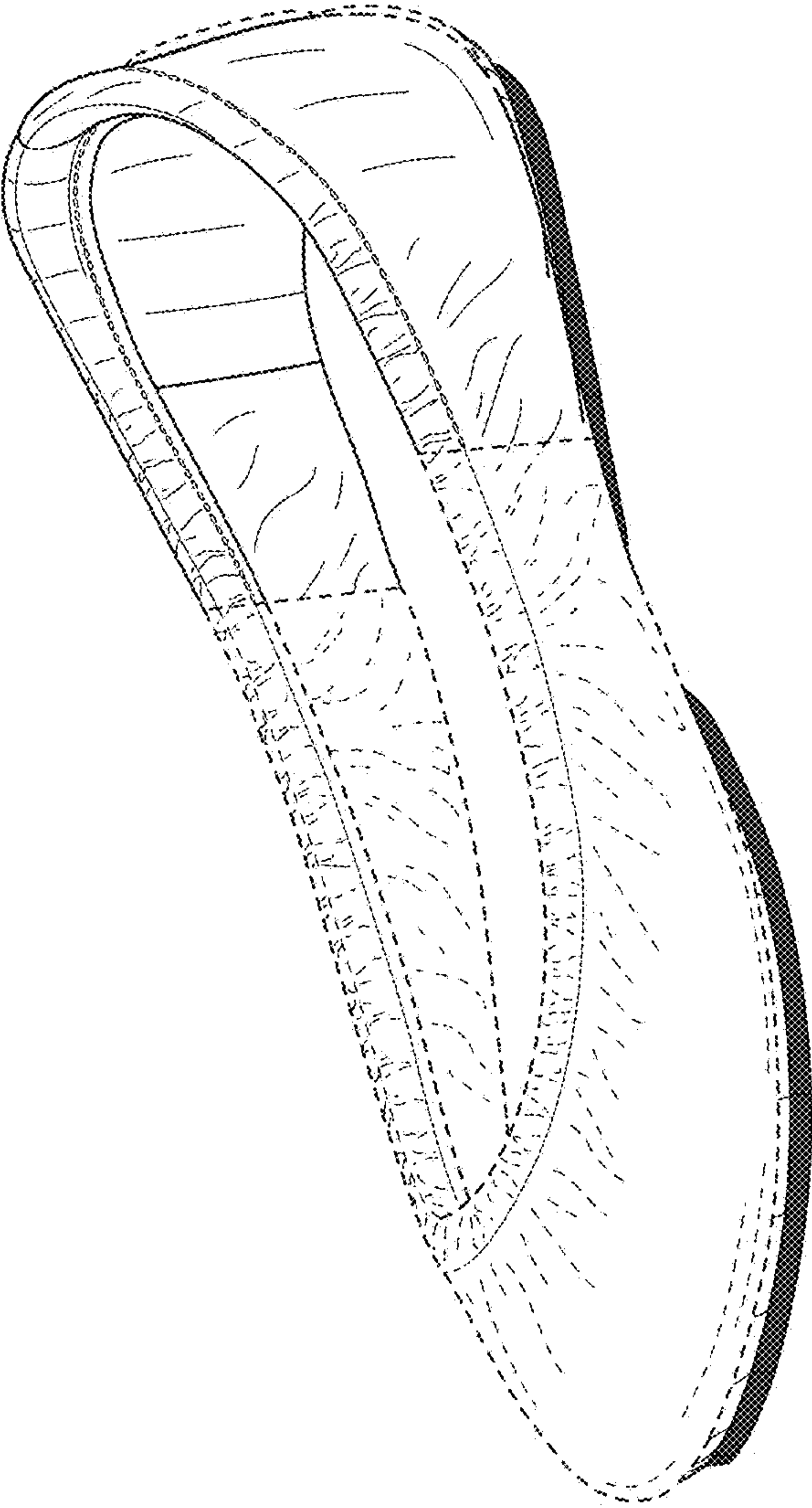

FIG. 50

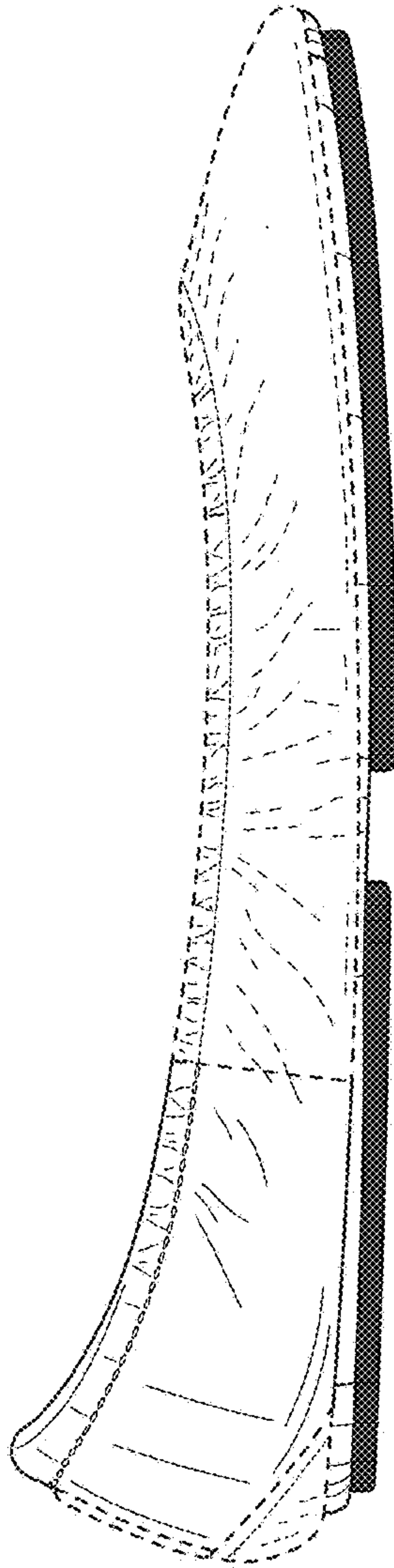

FIG. 51

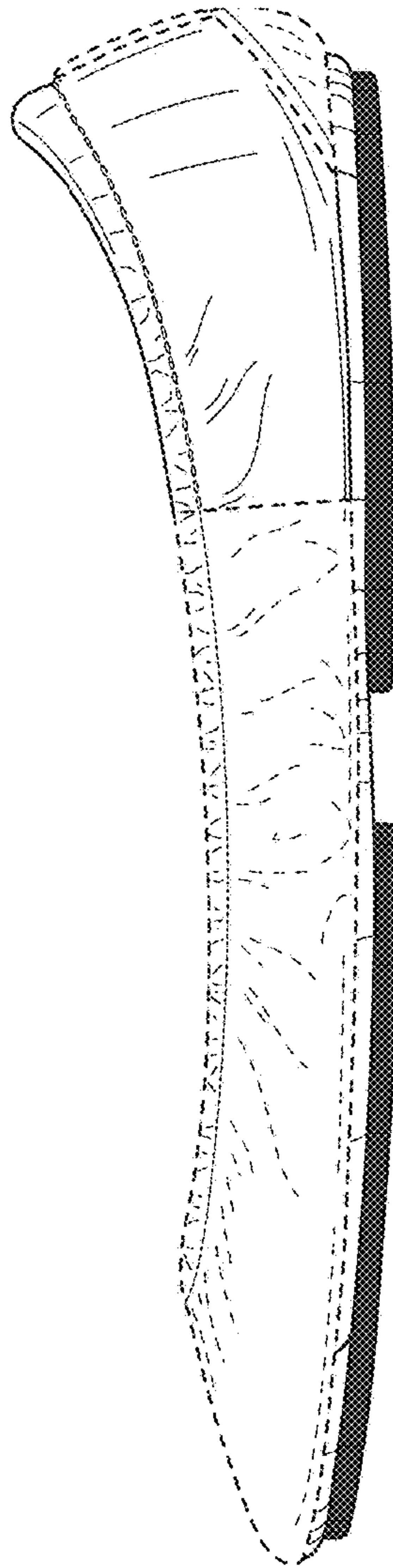

FIG. 52

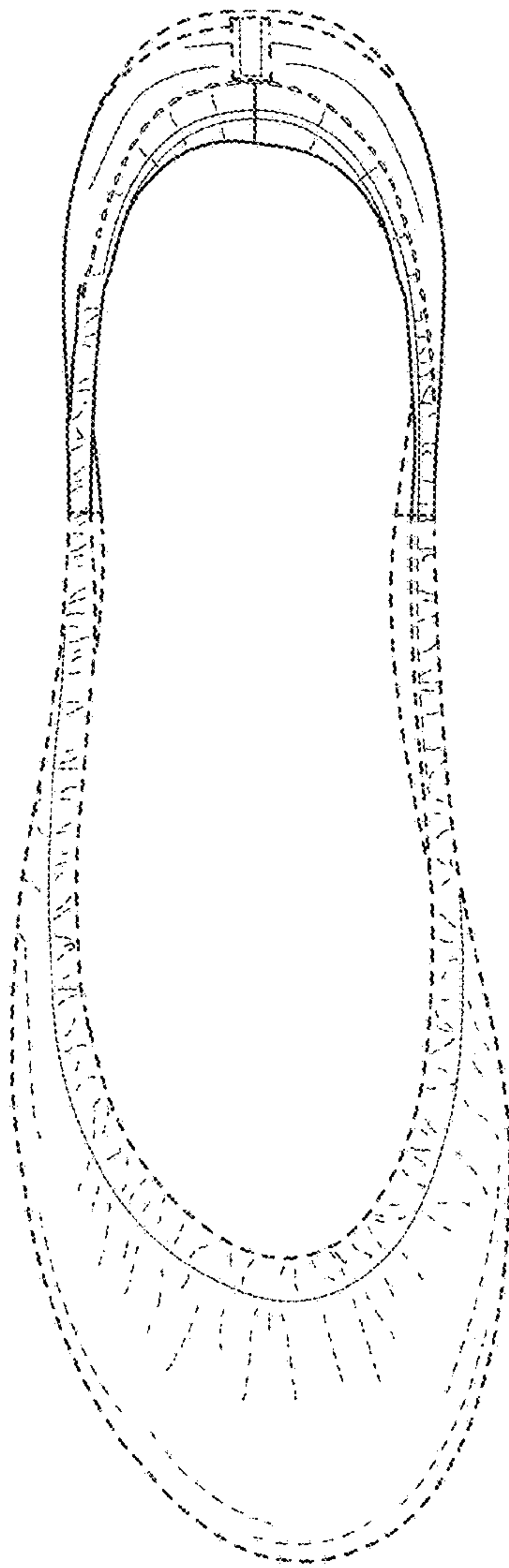

FIG. 53

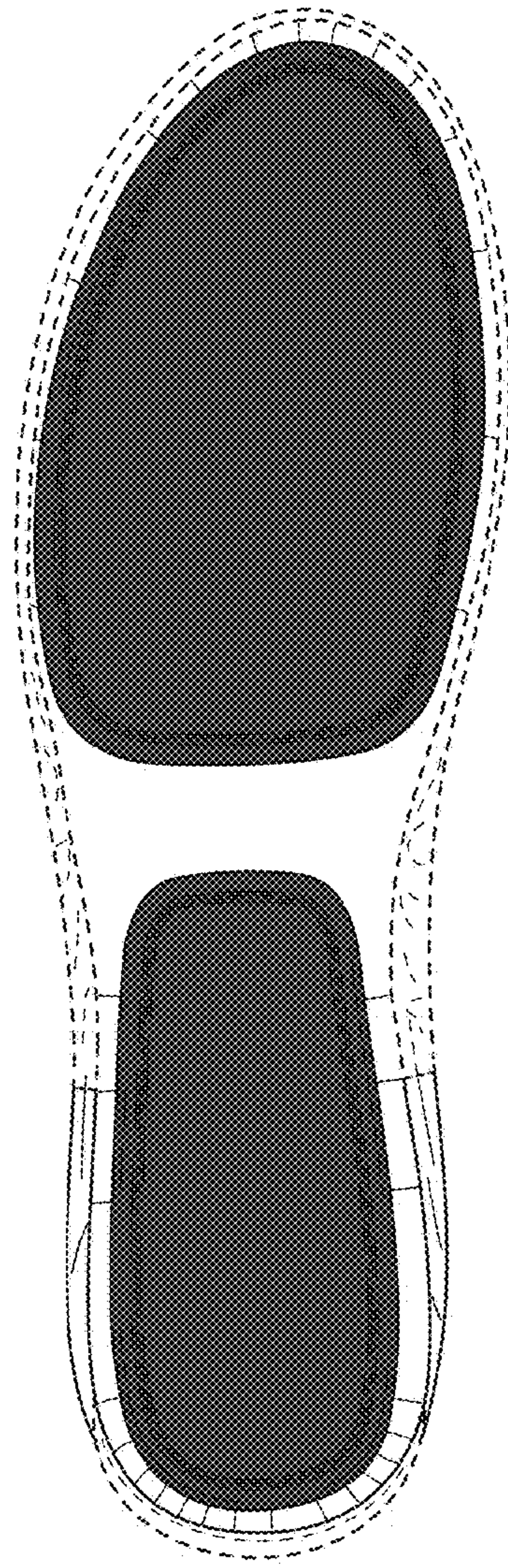

FIG. 54

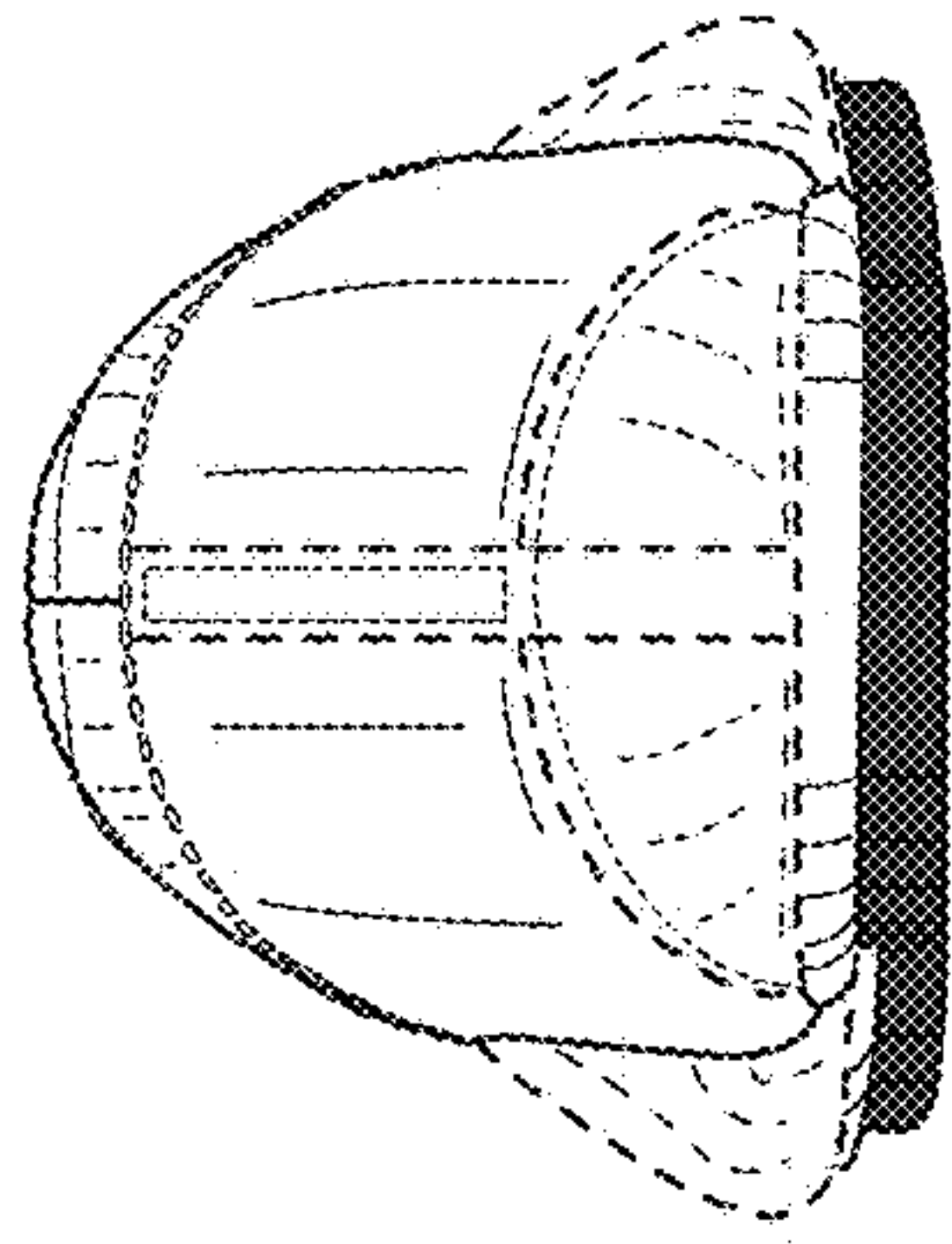

FIG. 56

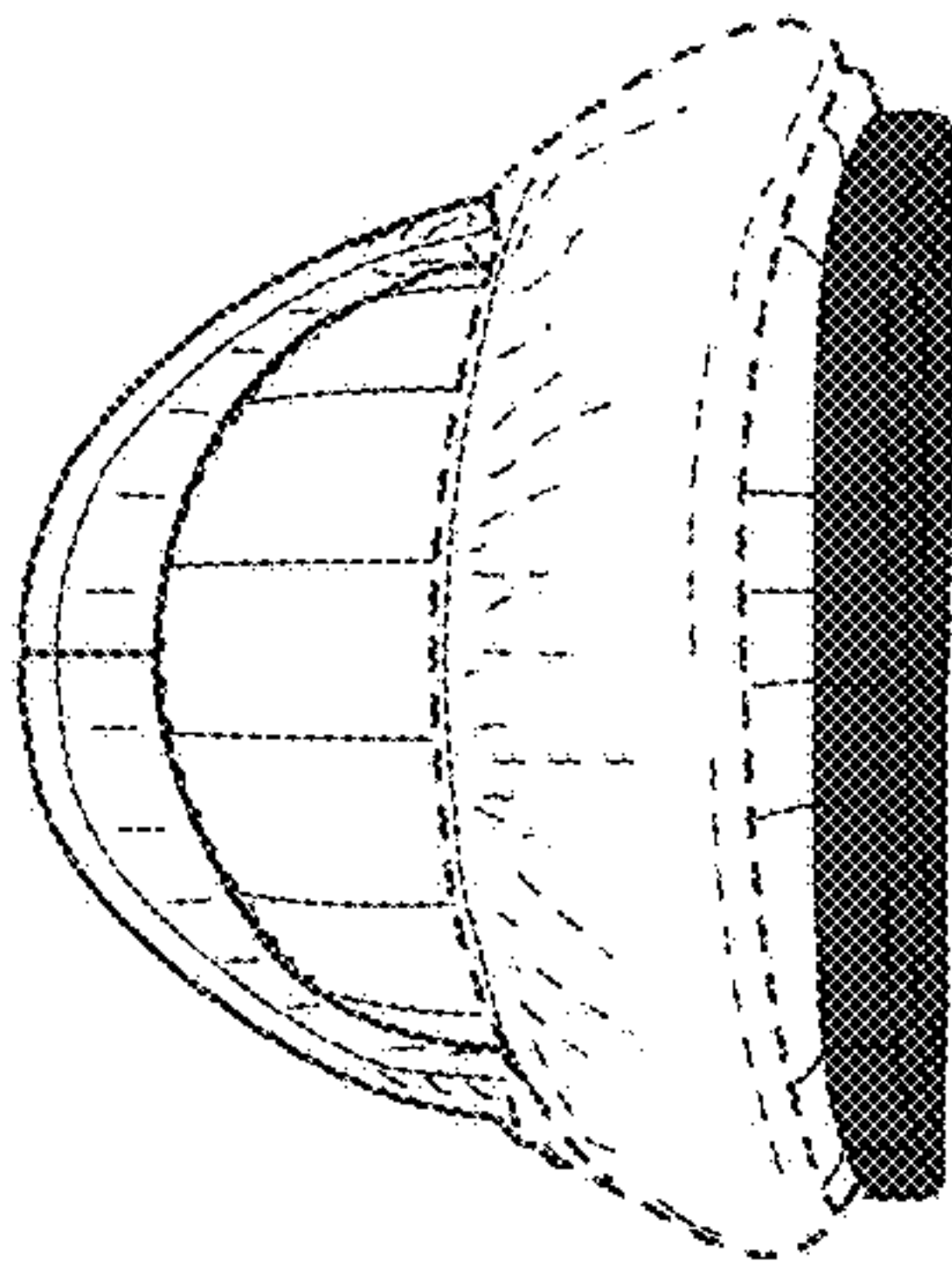

FIG. 55

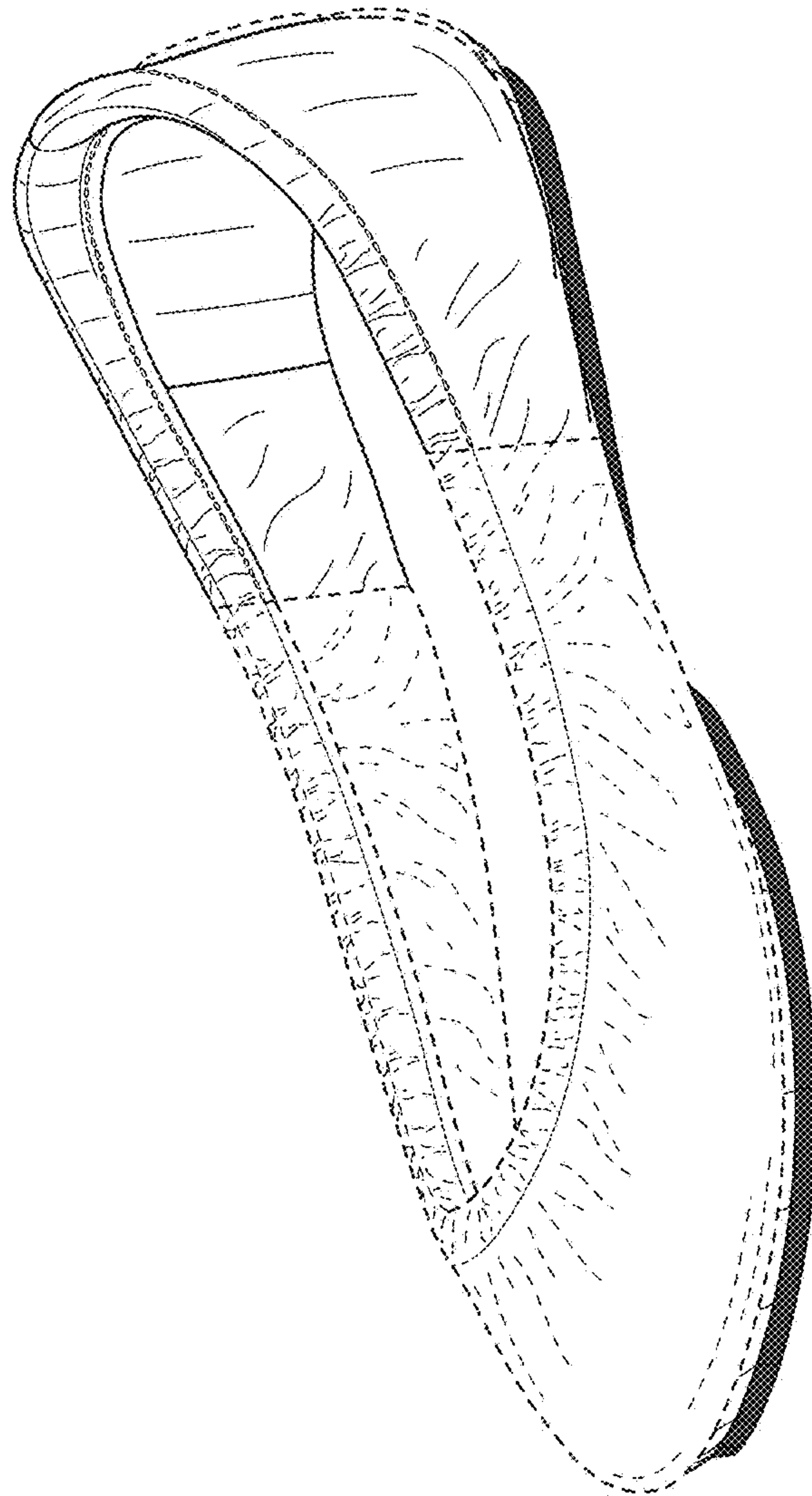

FIG. 57

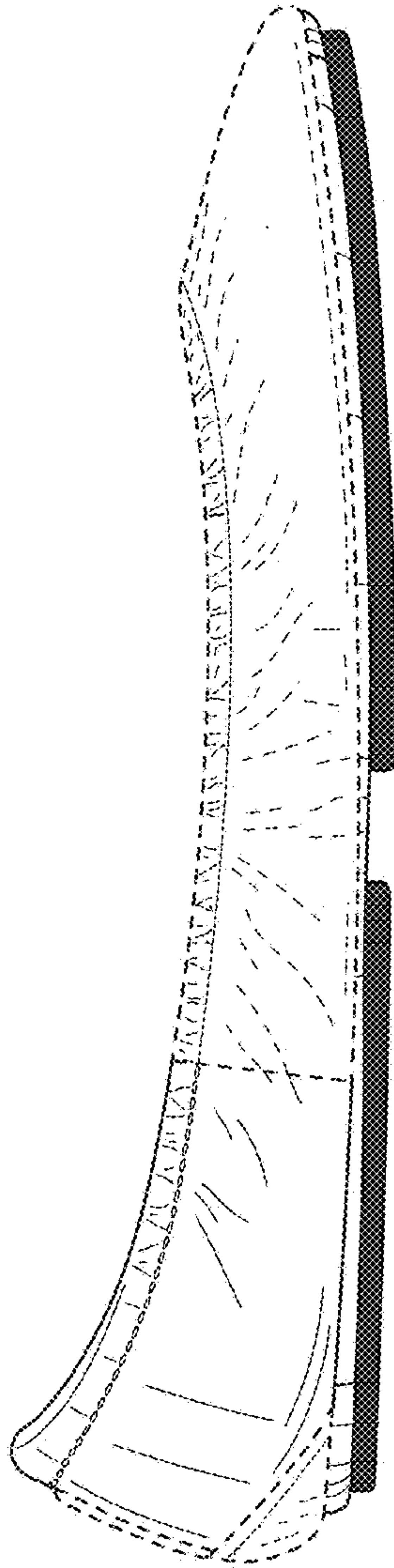

FIG. 58

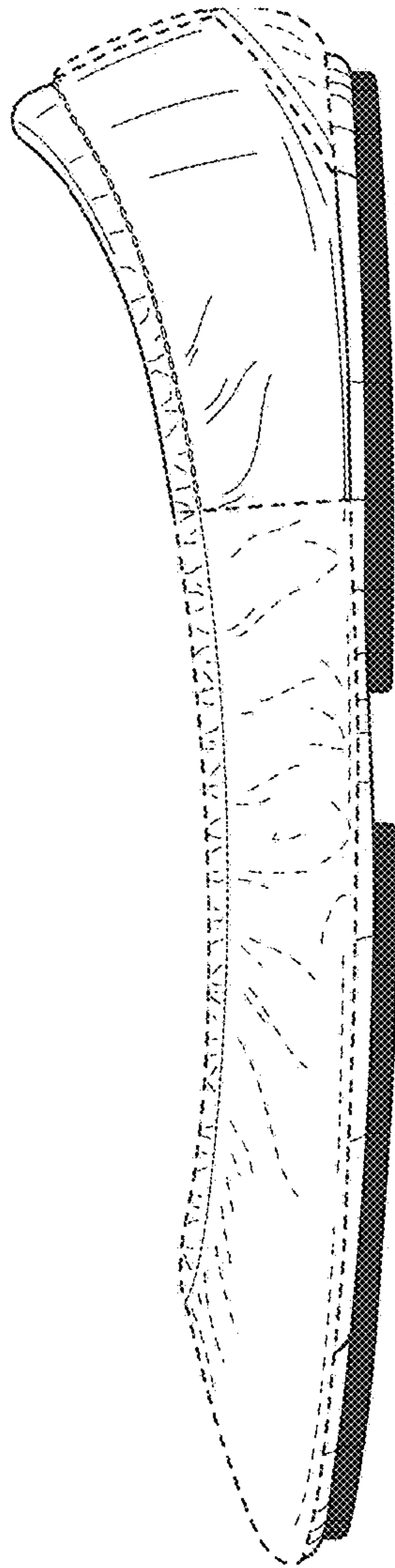

FIG. 59

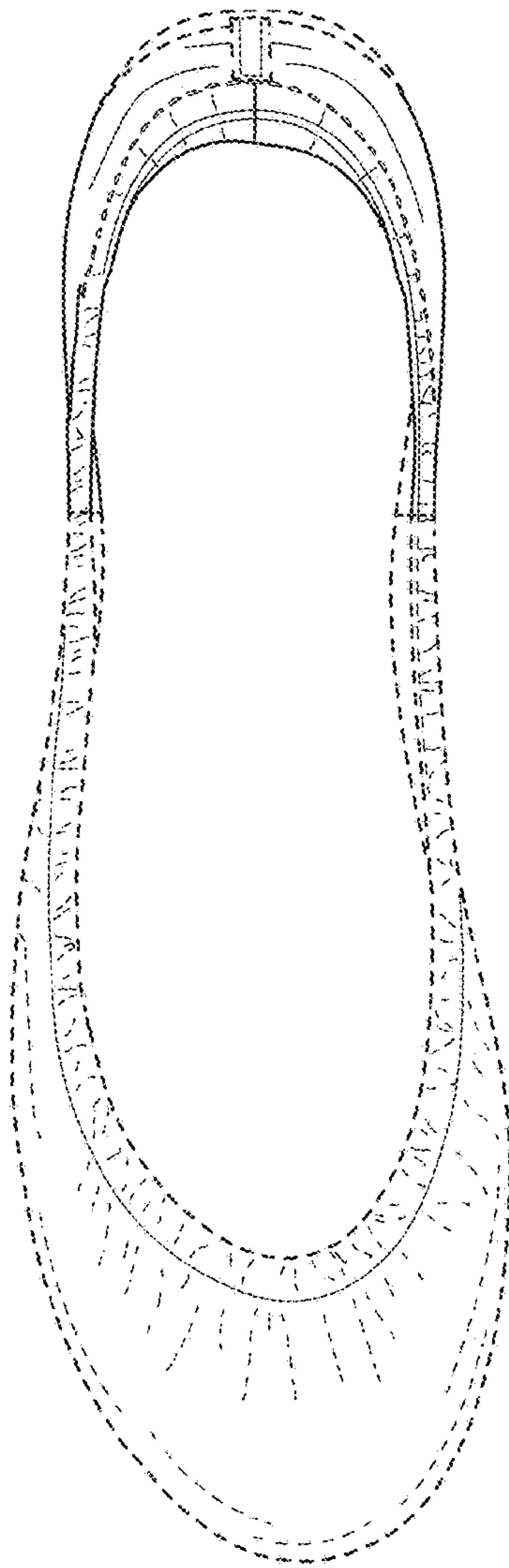

FIG. 60

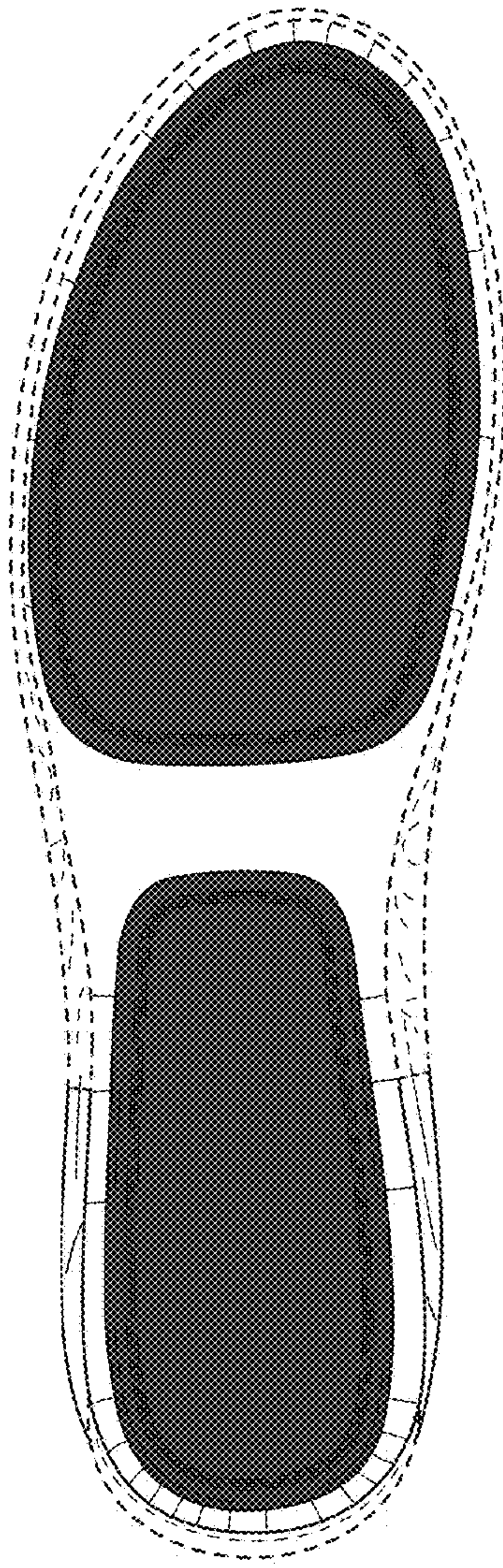

FIG. 61

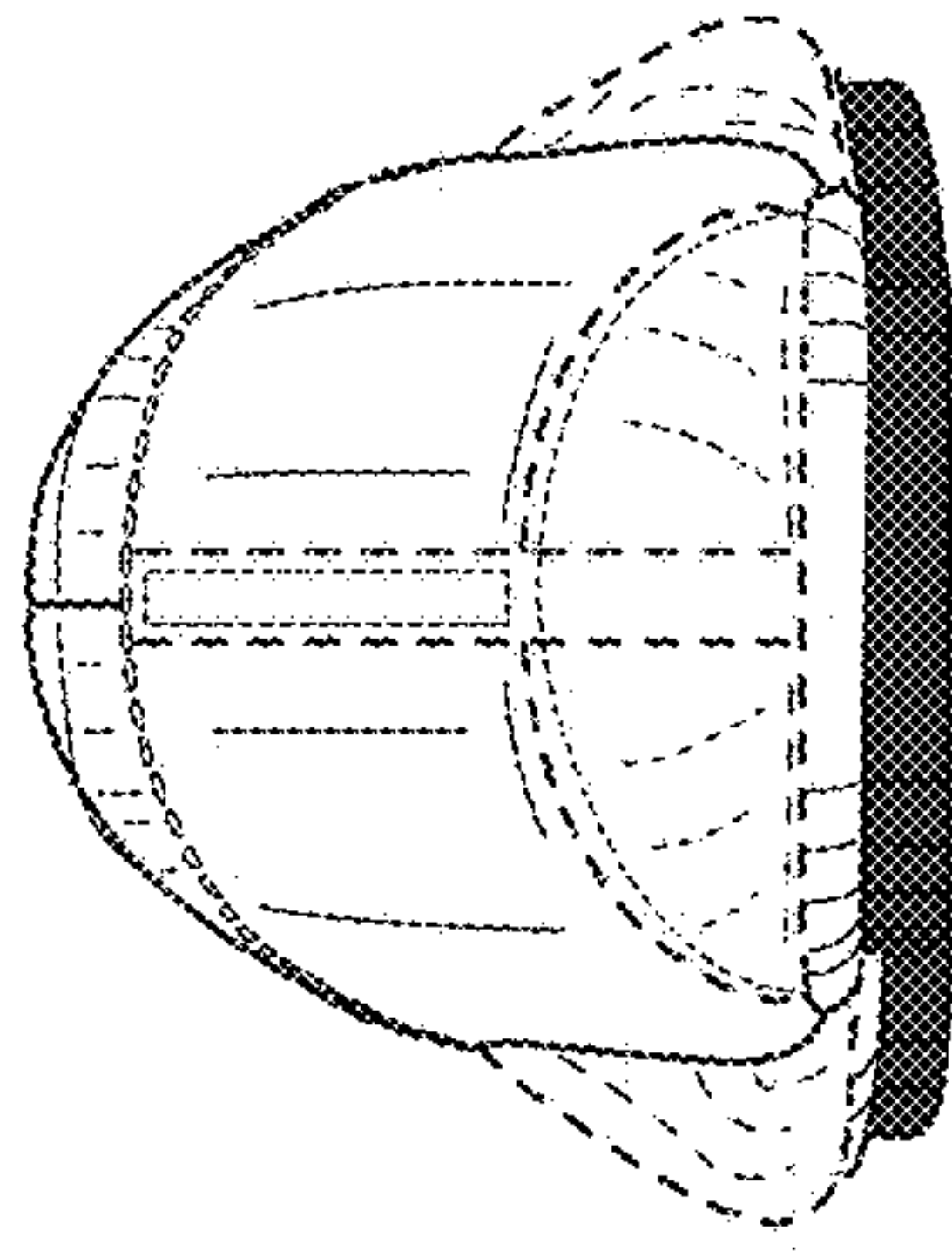

FIG. 63

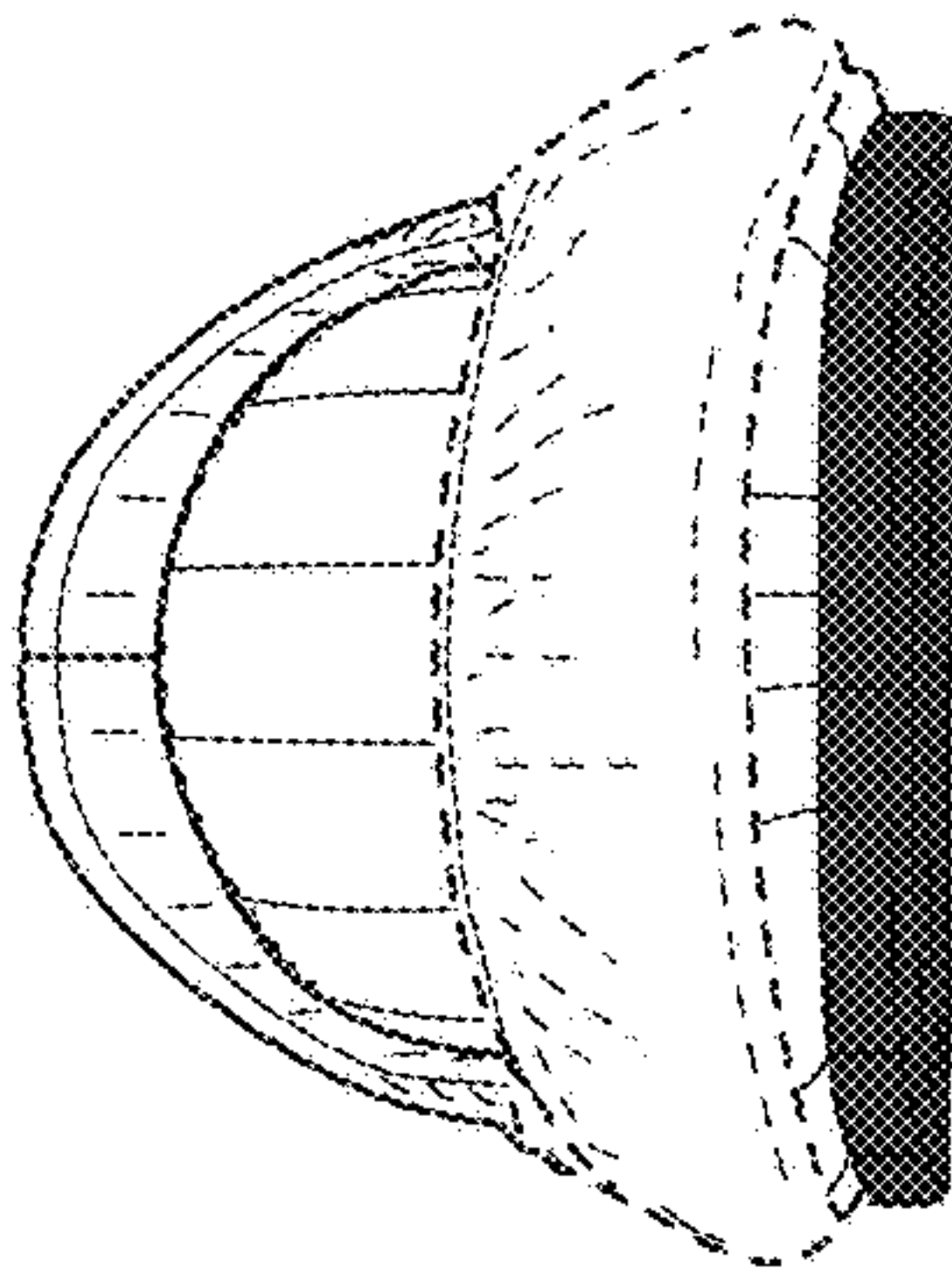

FIG. 62

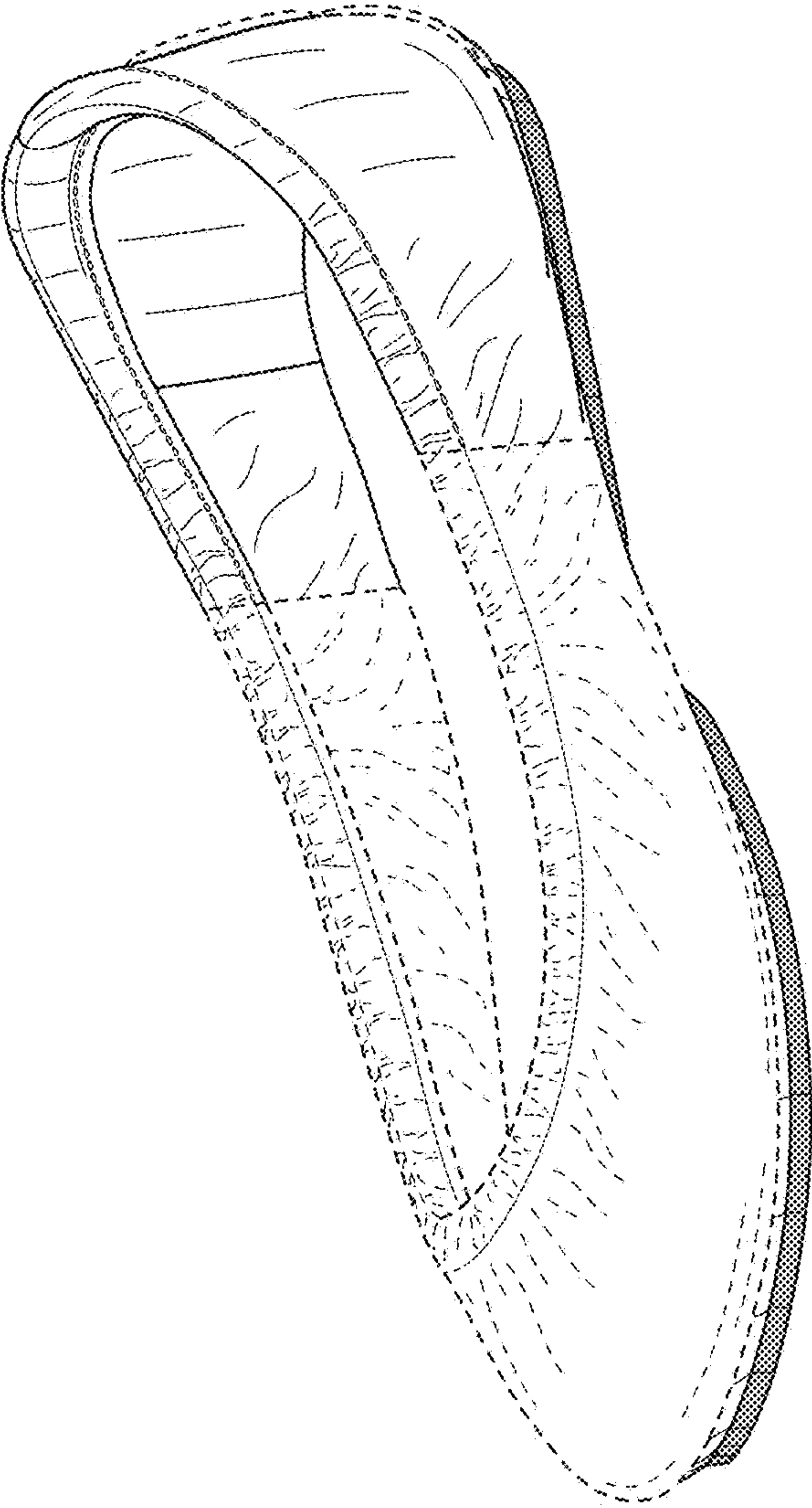

FIG. 64

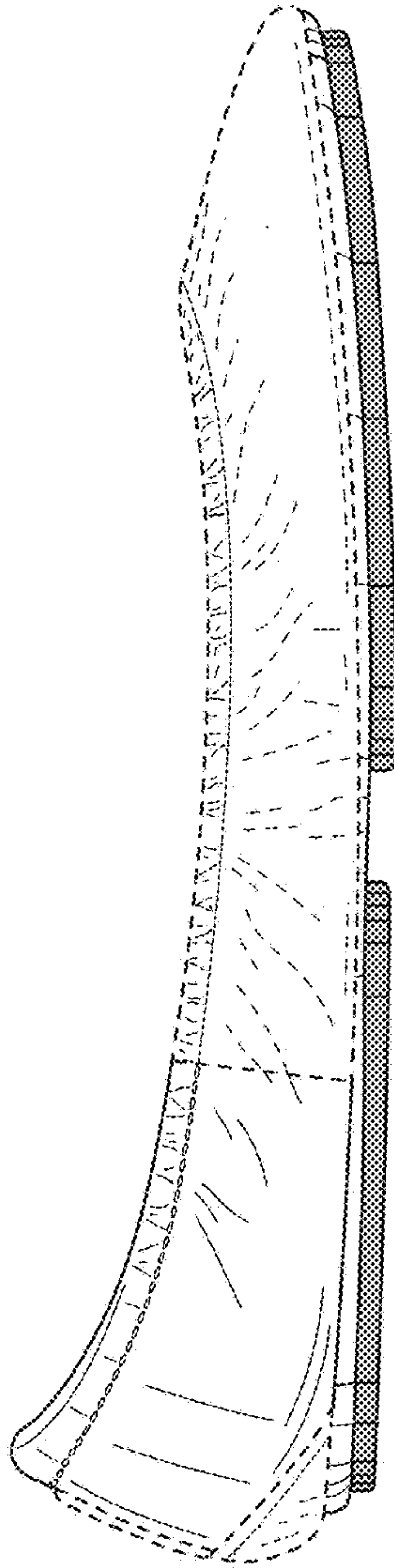

FIG. 65

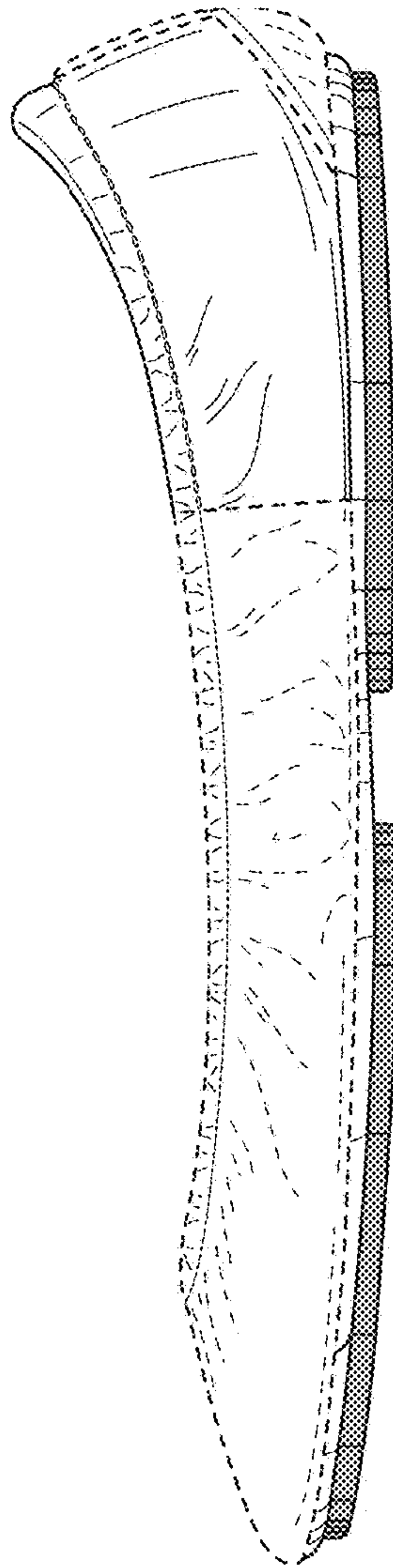

FIG. 66

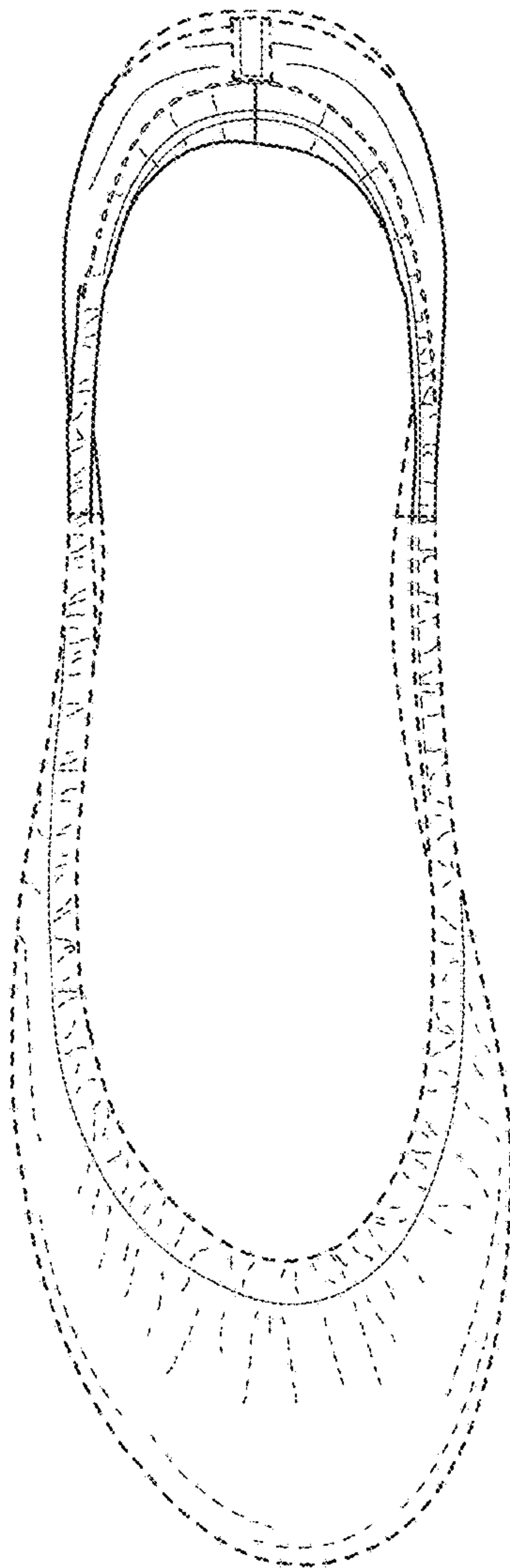

FIG. 67

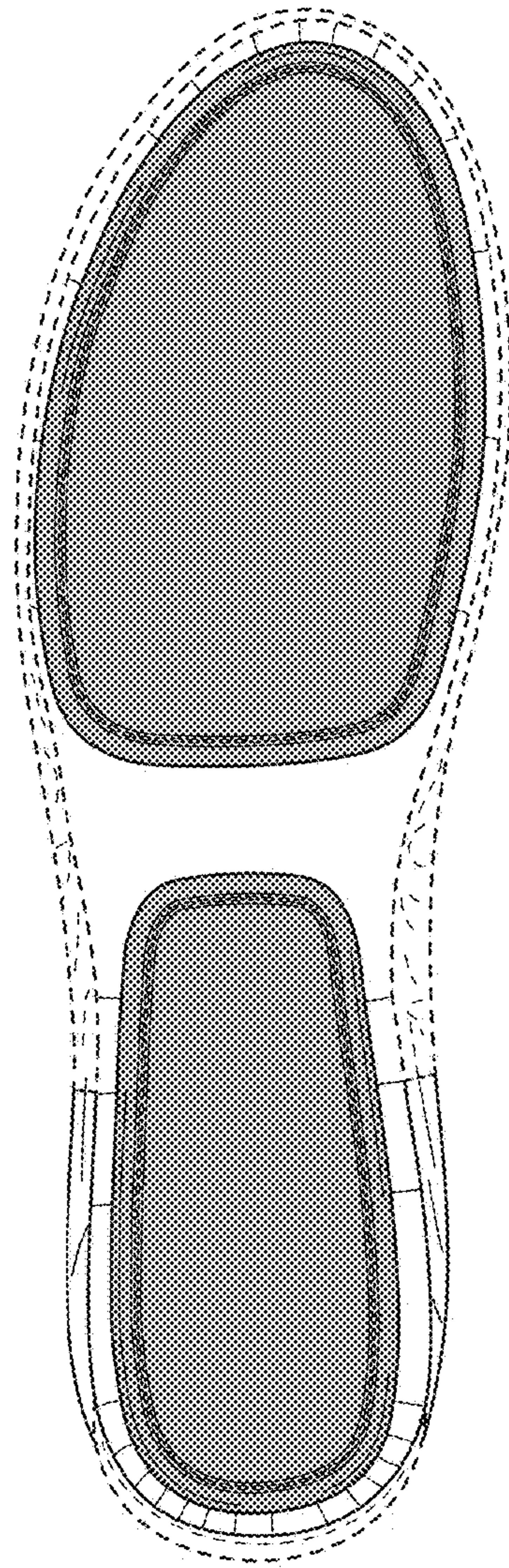

FIG. 68

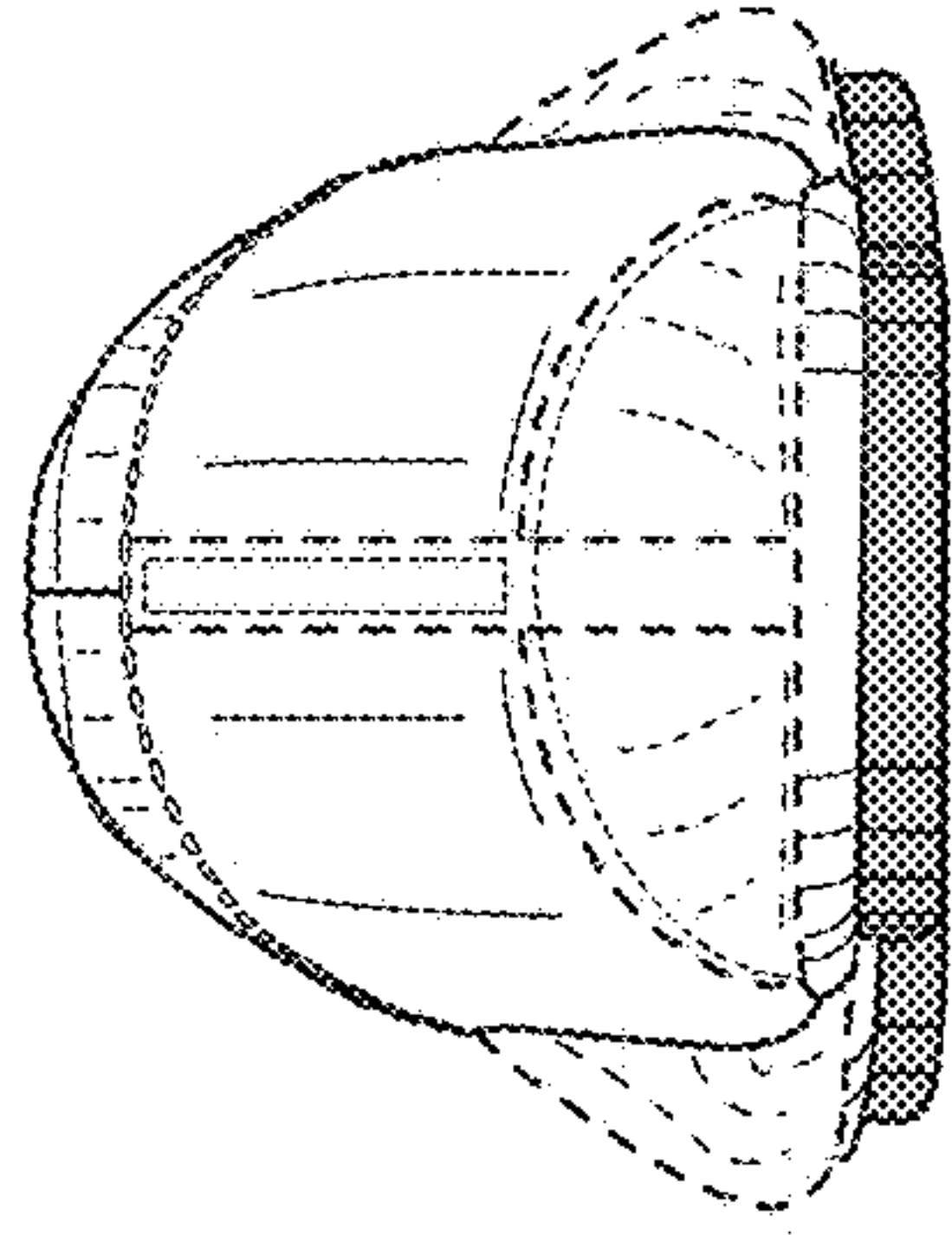

FIG. 70

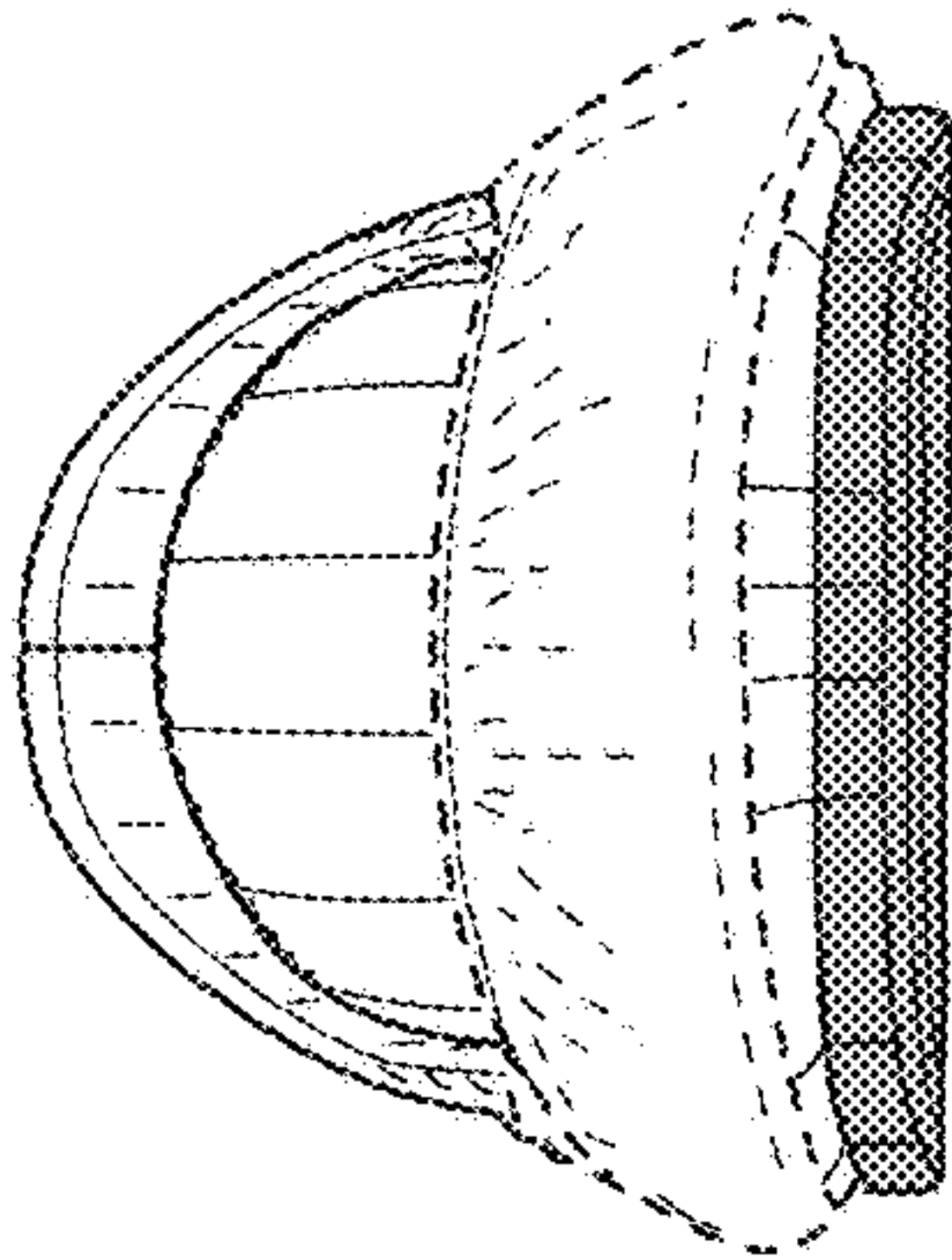

FIG. 69

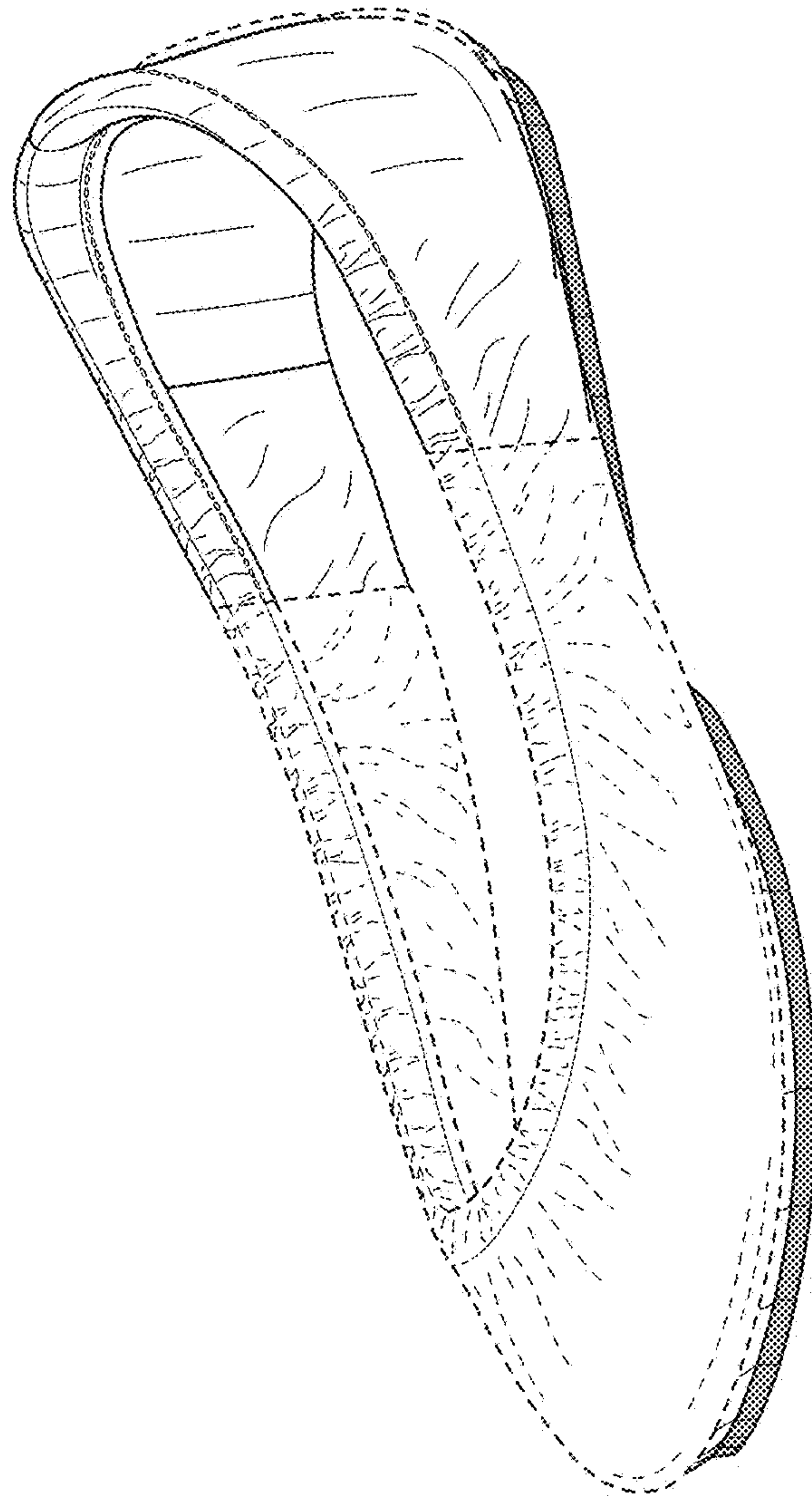

FIG. 71

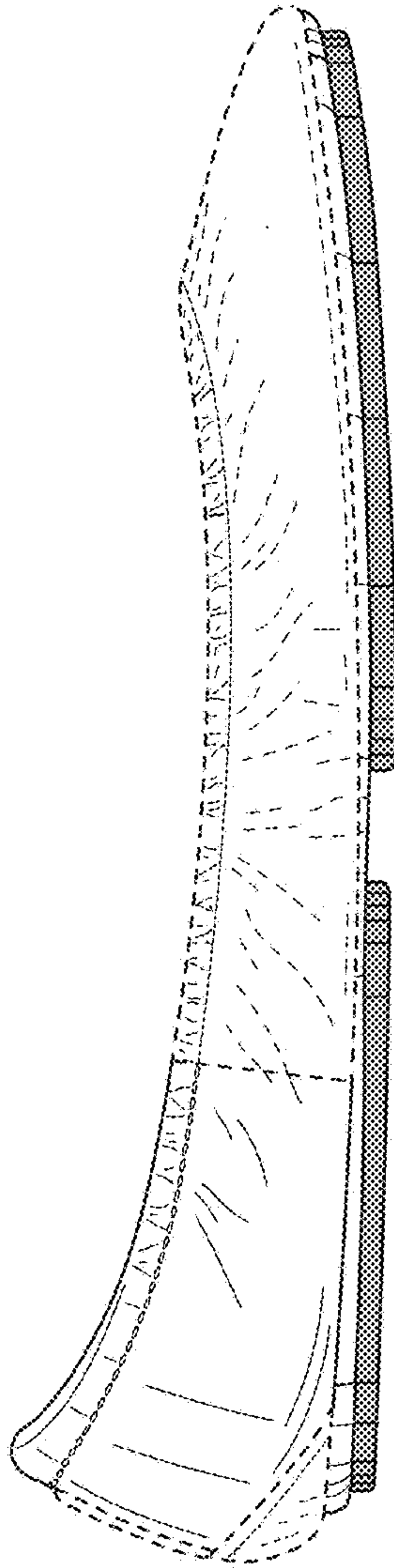

FIG. 72

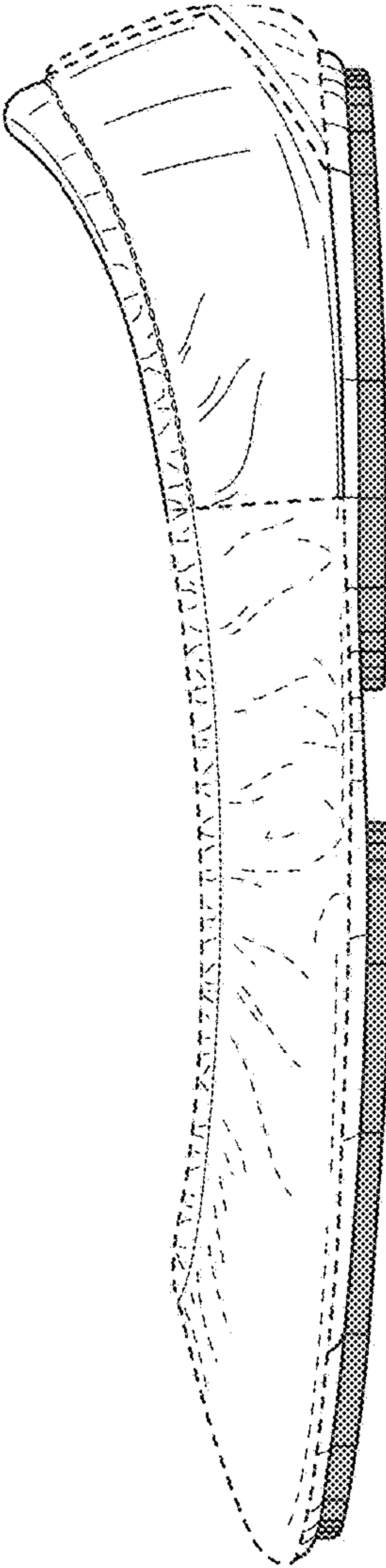

FIG. 73

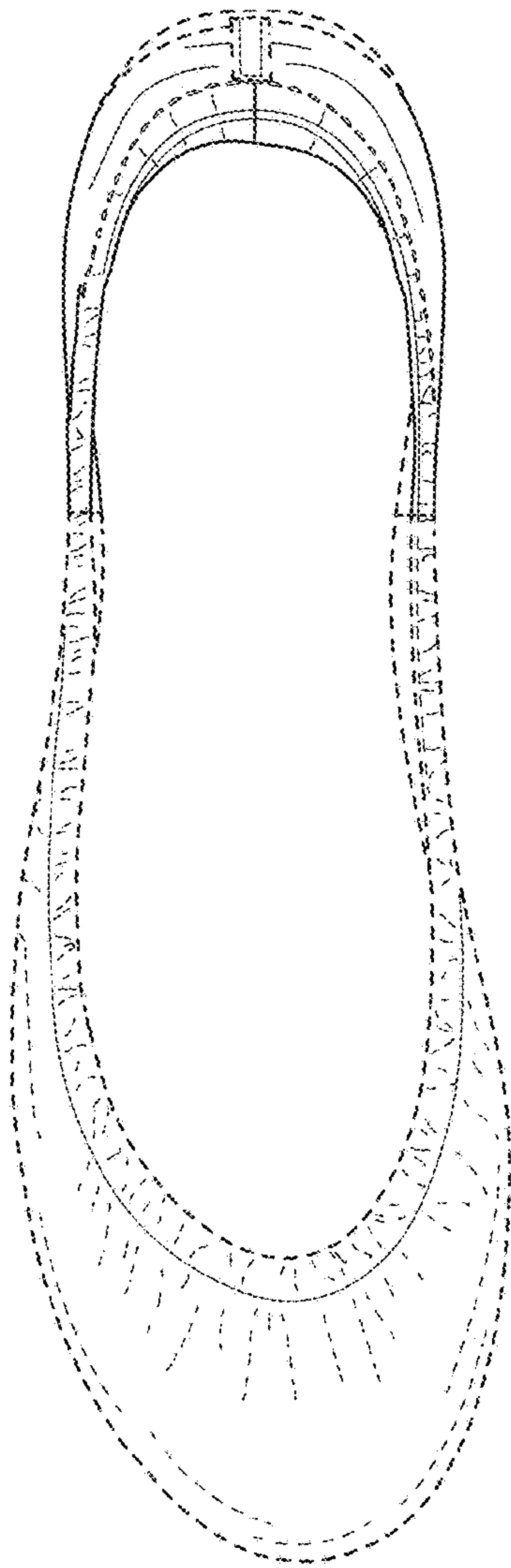

FIG. 74

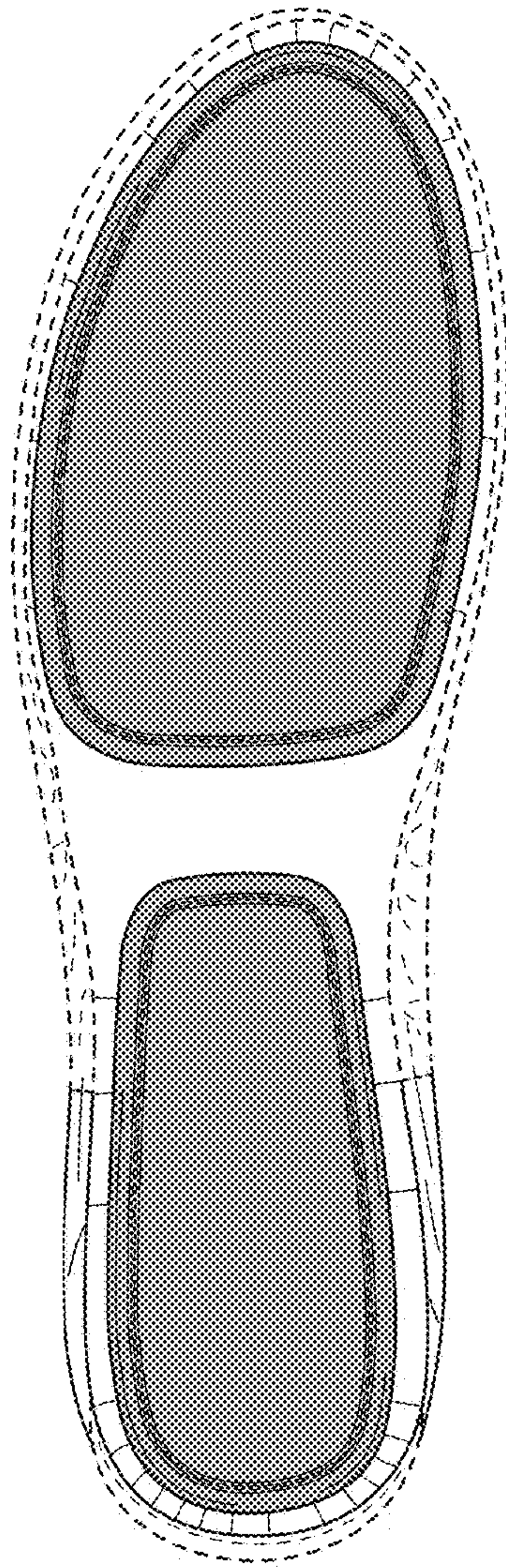

FIG. 75

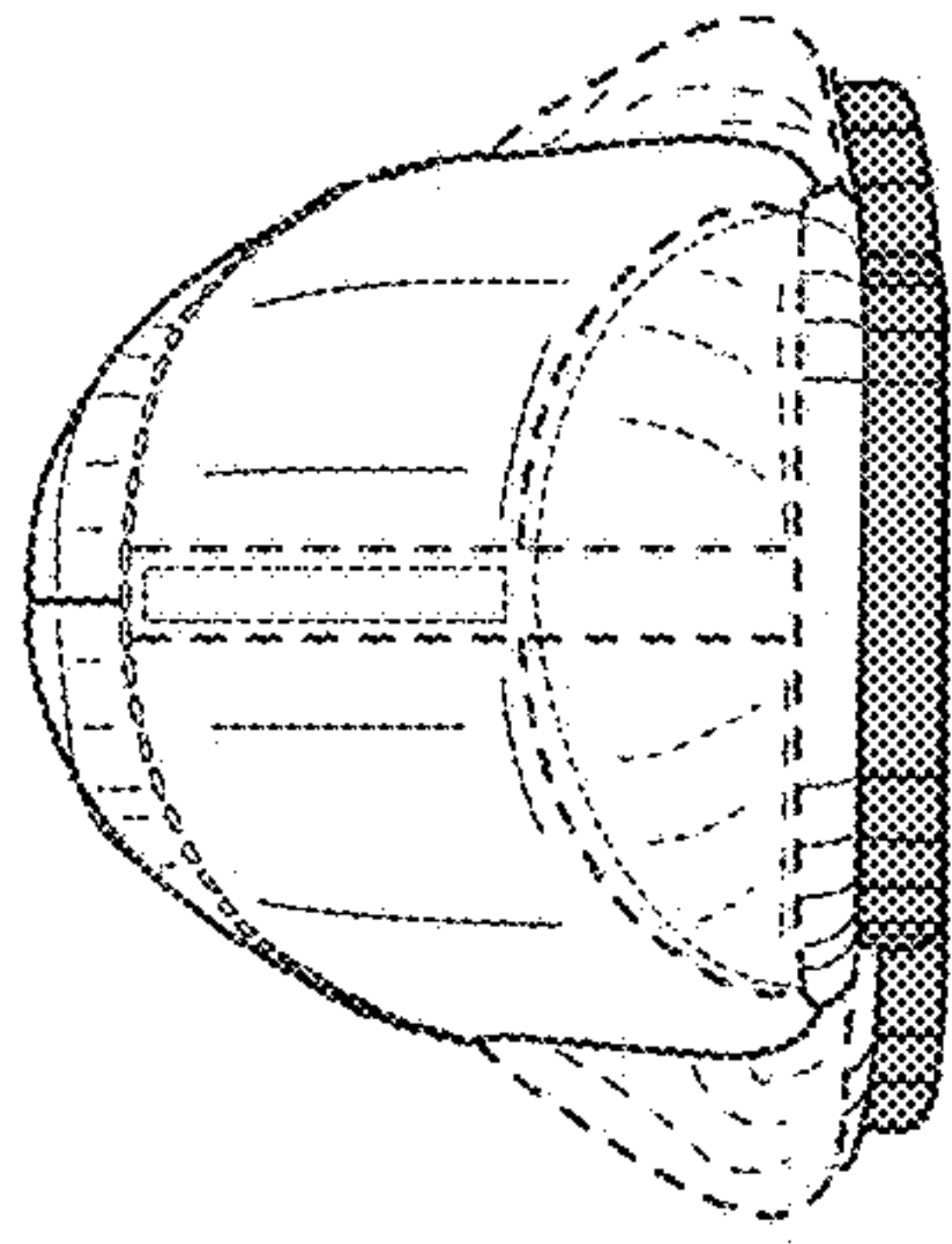

FIG. 77

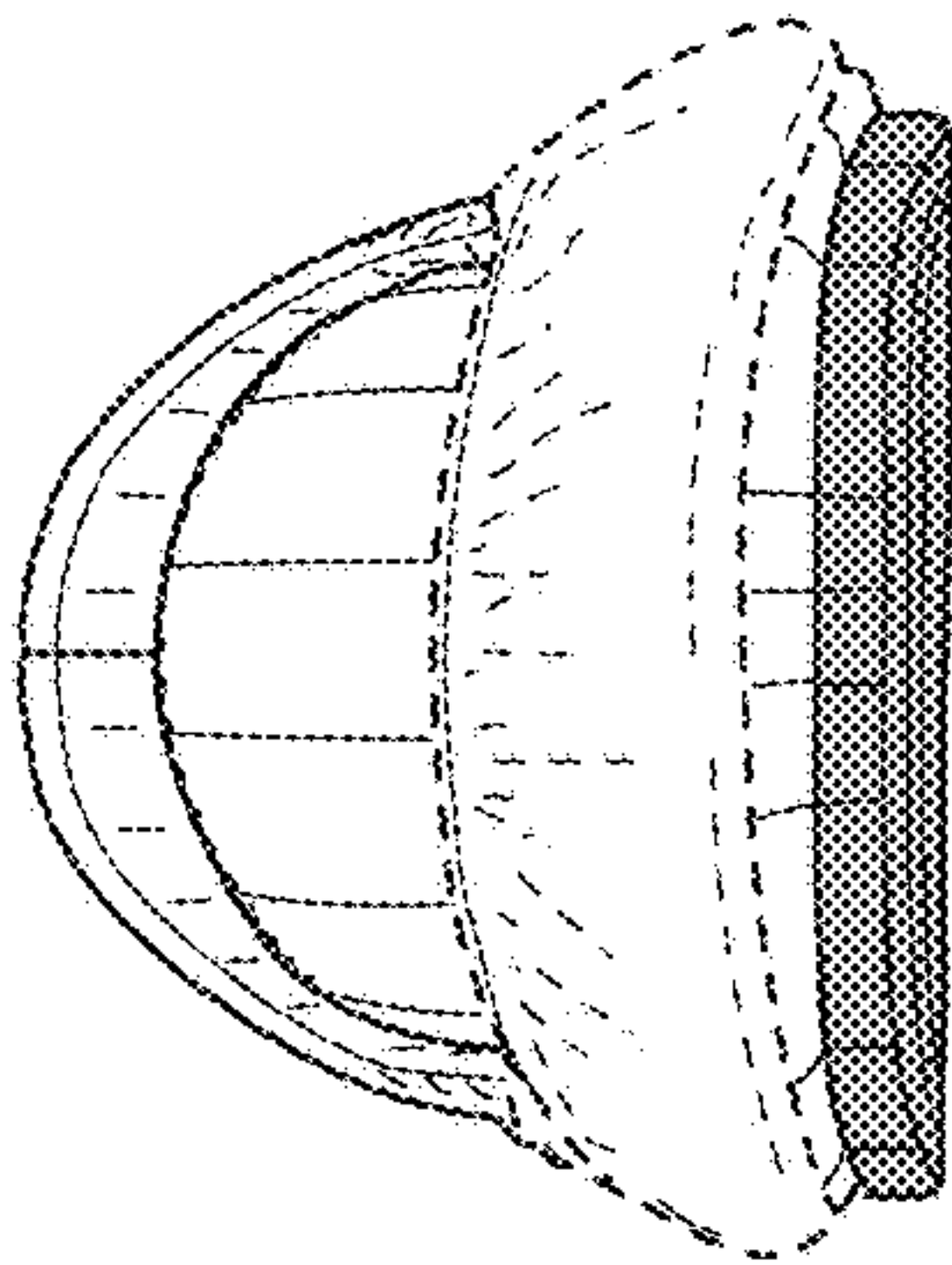

FIG. 76

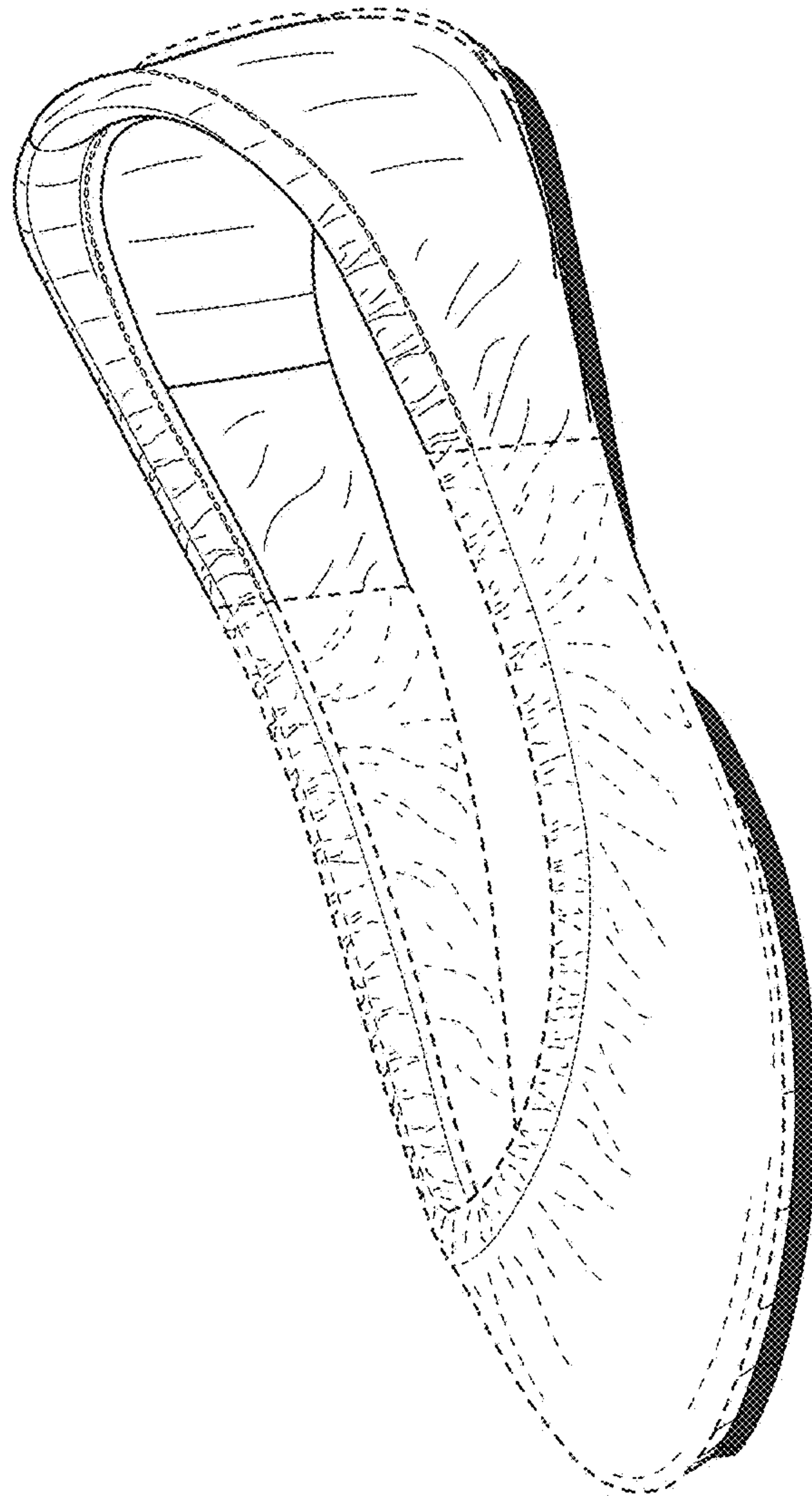

FIG. 78

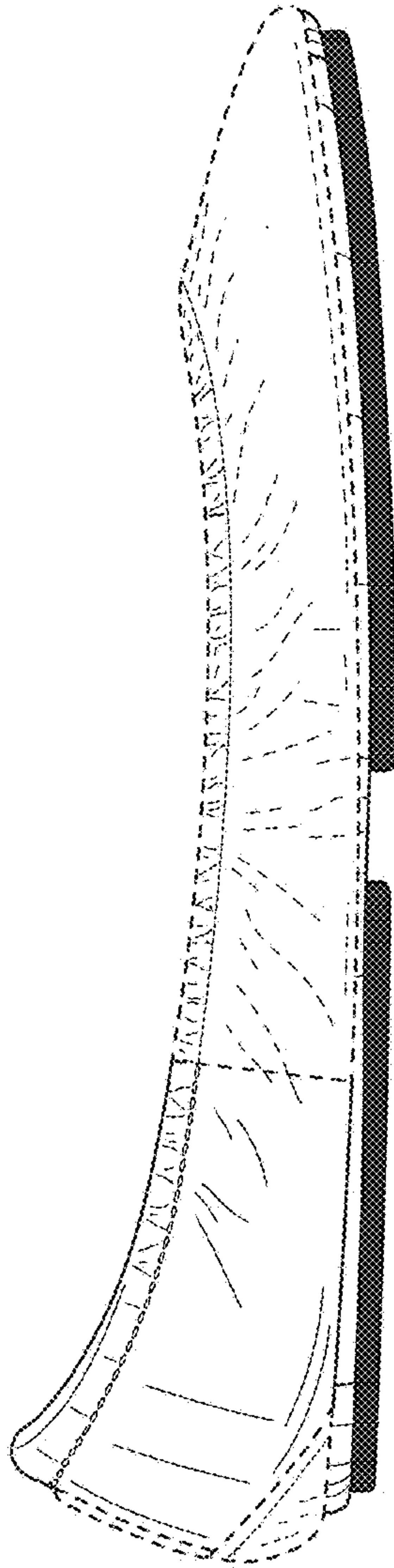

FIG. 79

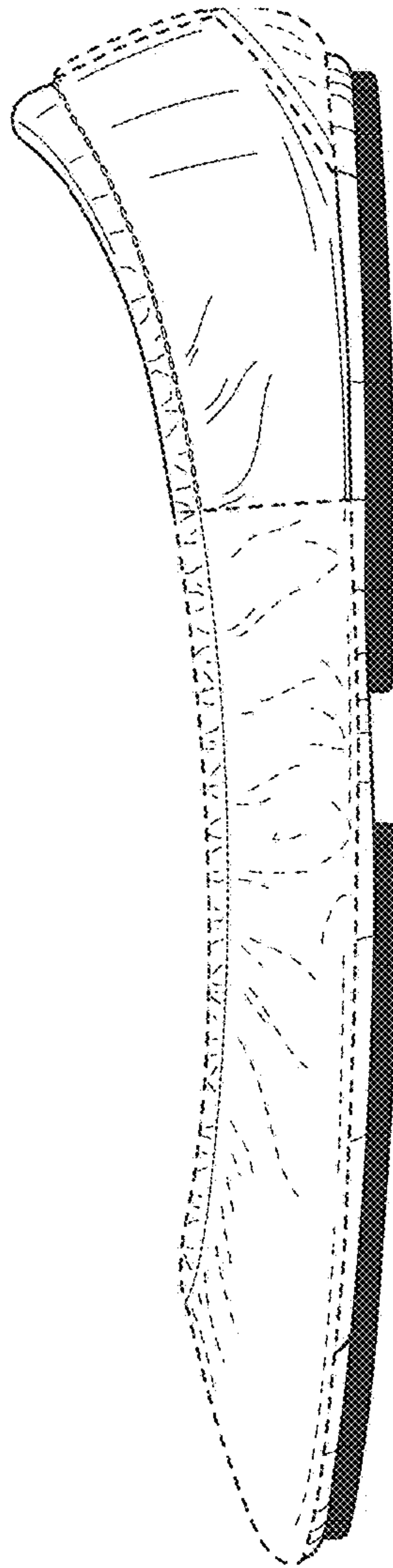

FIG. 80

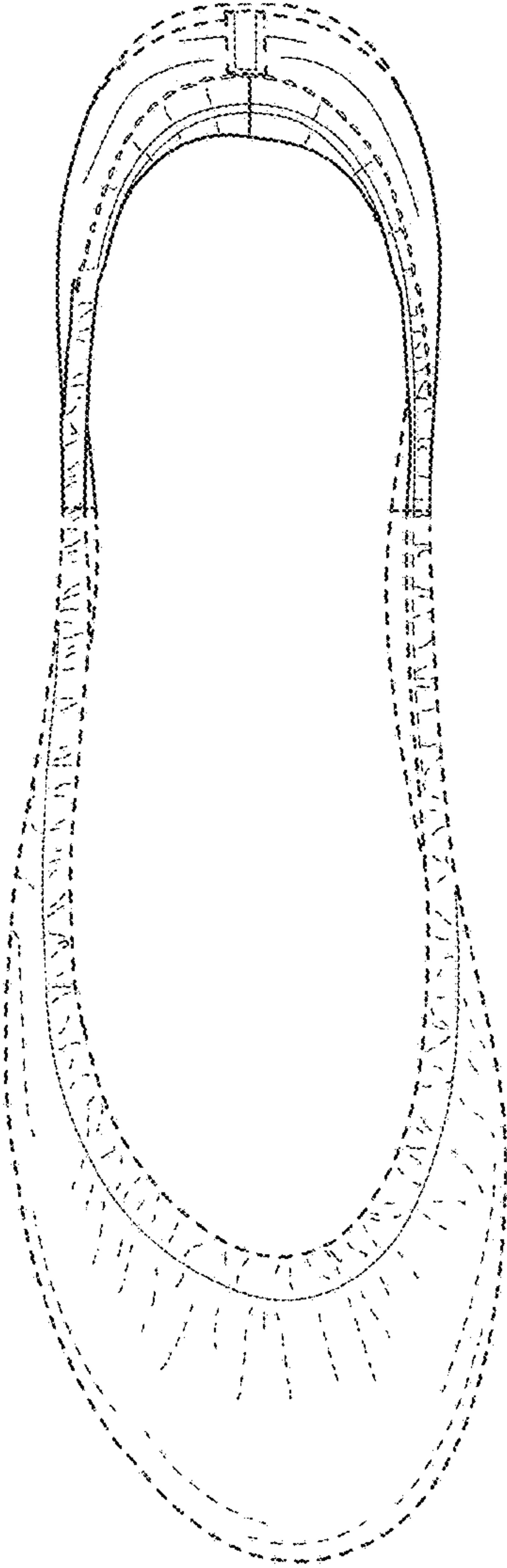

FIG. 81

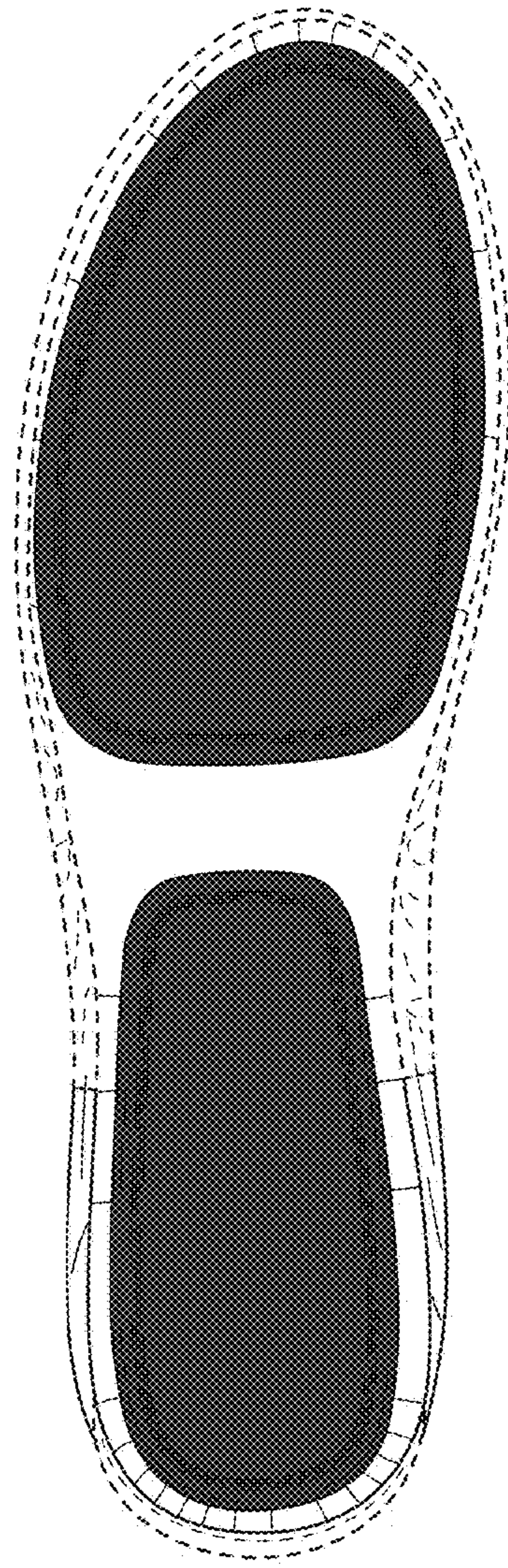

FIG. 82

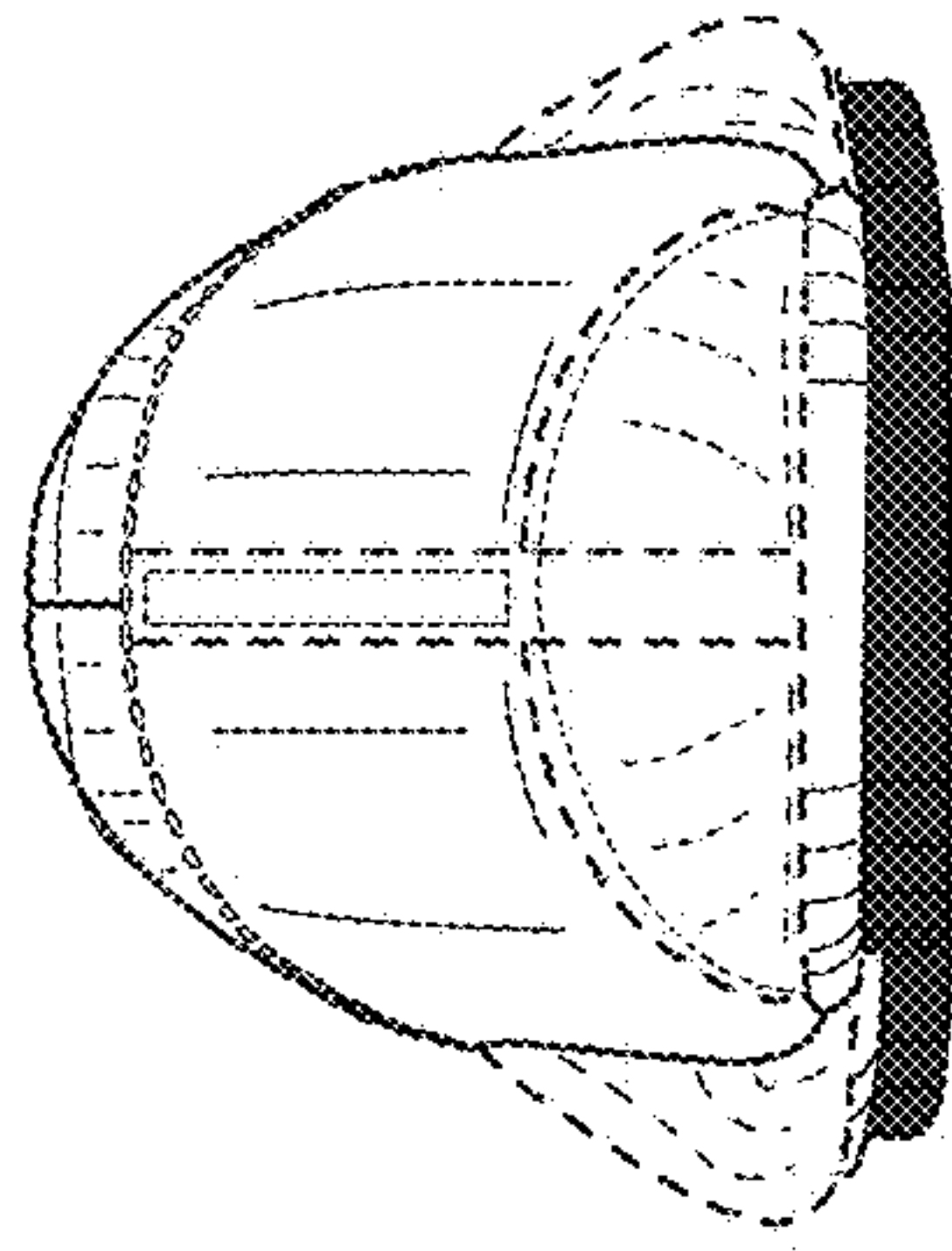

FIG. 84

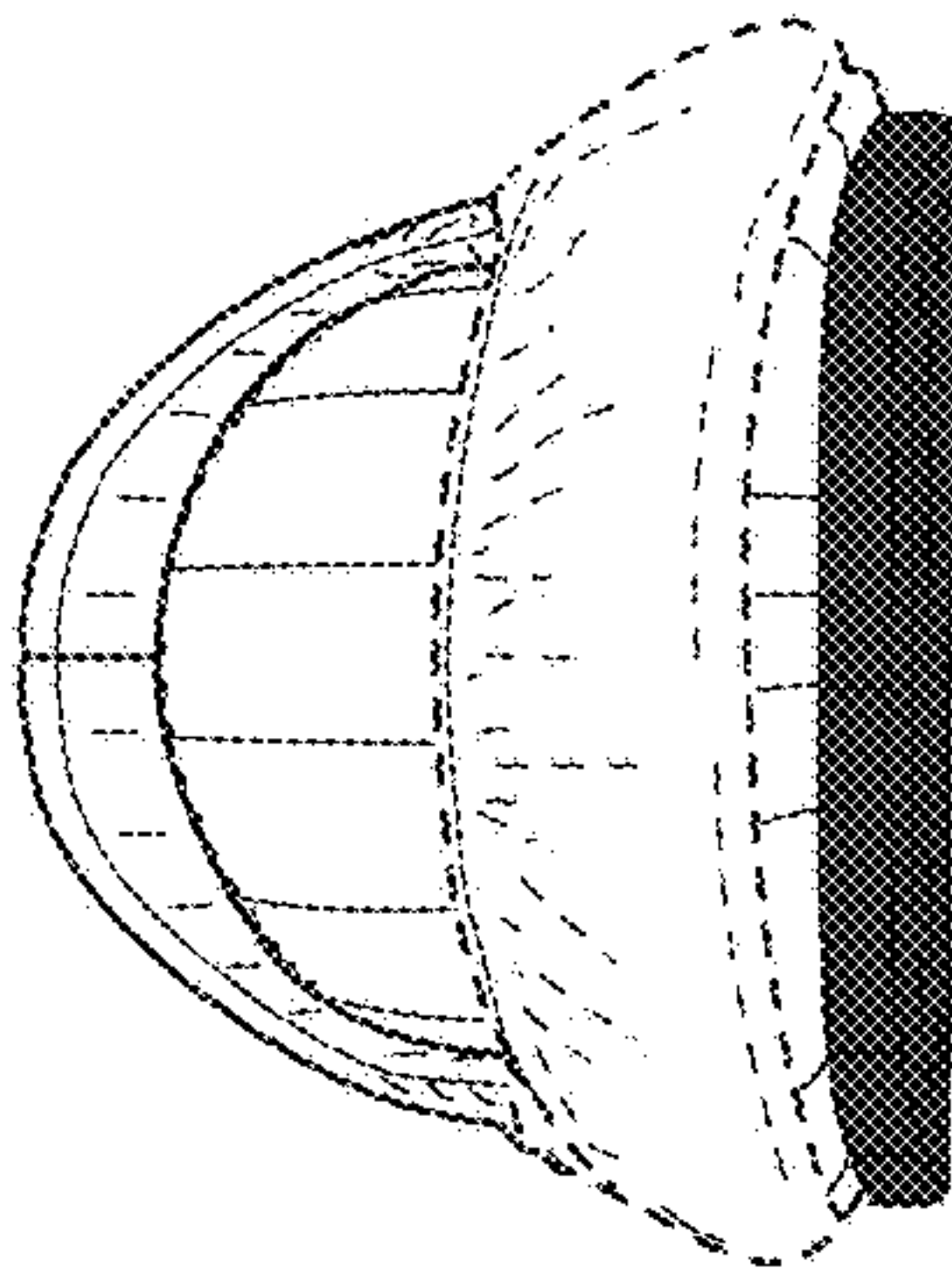

FIG. 83

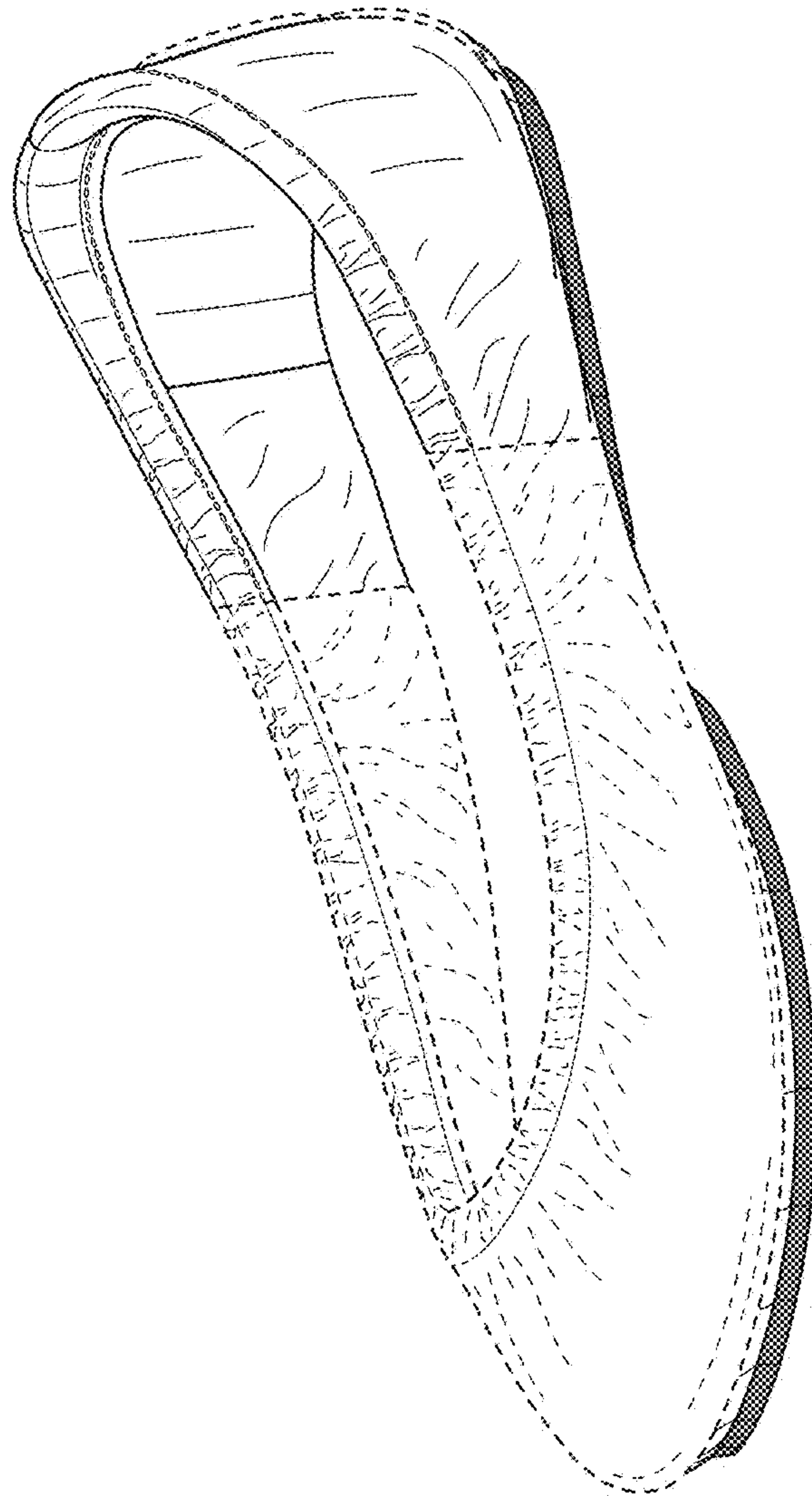

FIG. 85

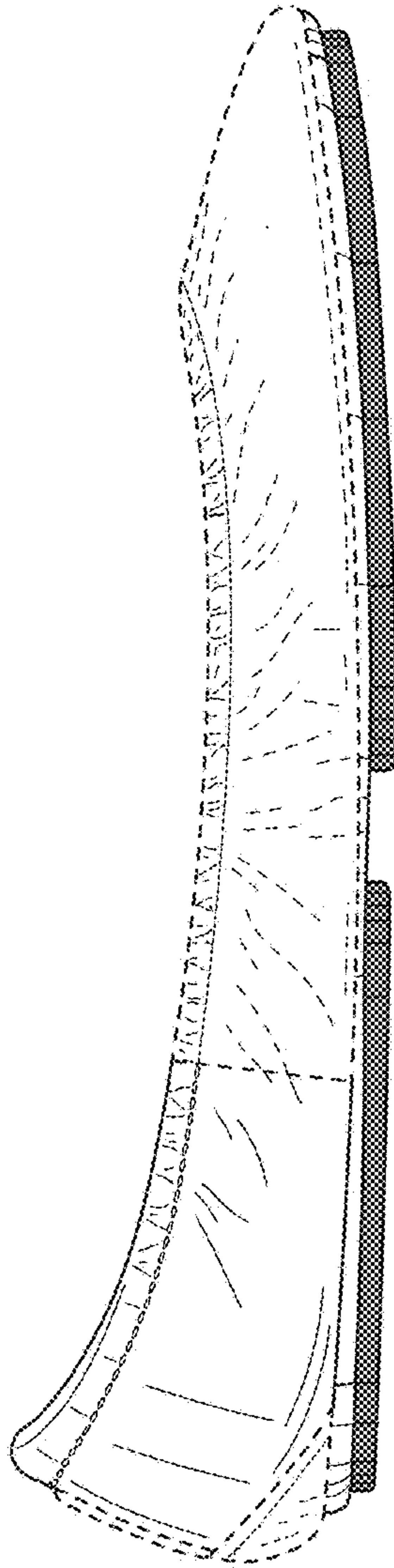

FIG. 86

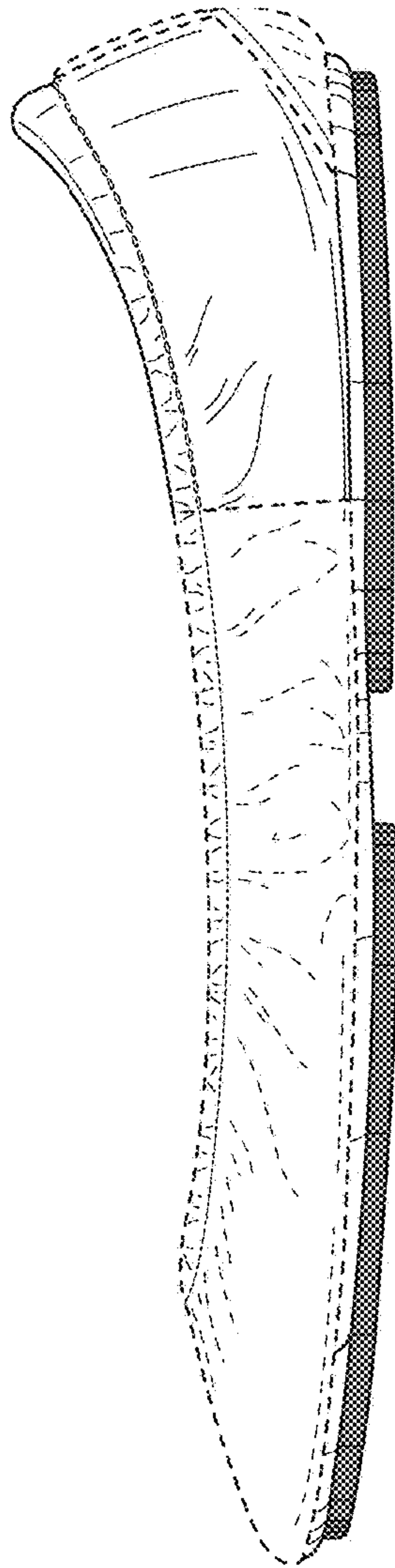

FIG. 87

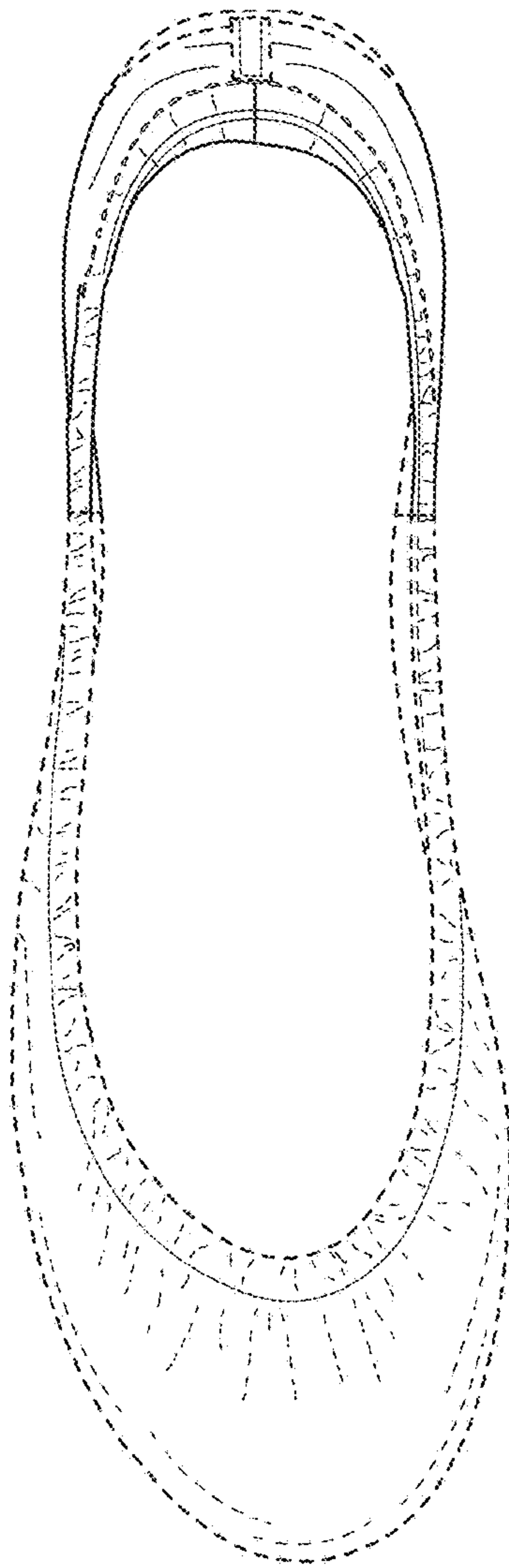

FIG. 88

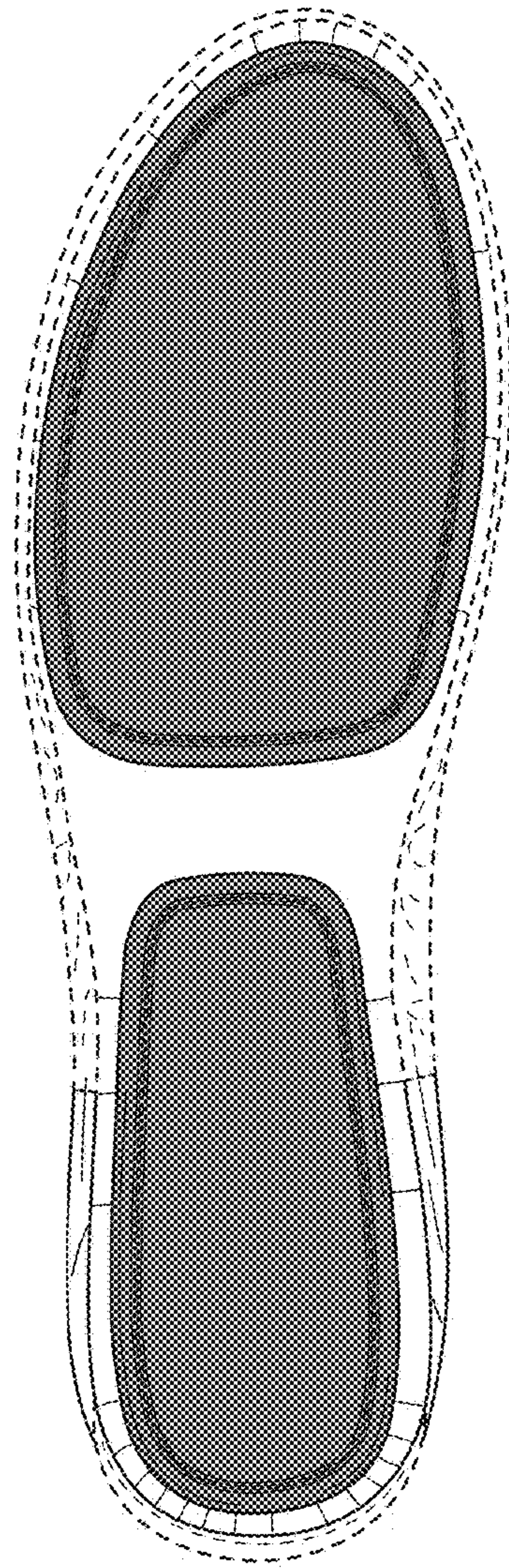

FIG. 89

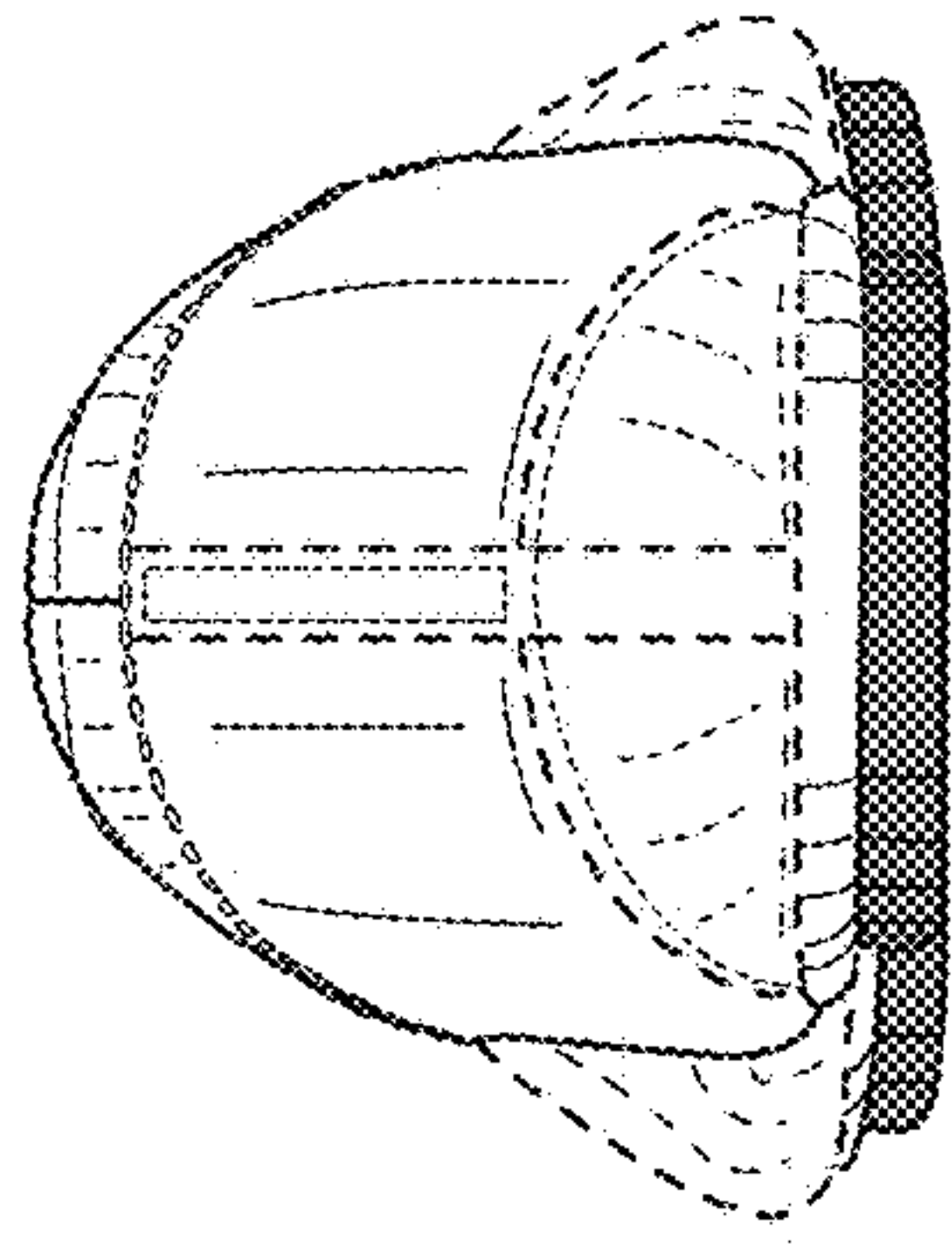

FIG. 91

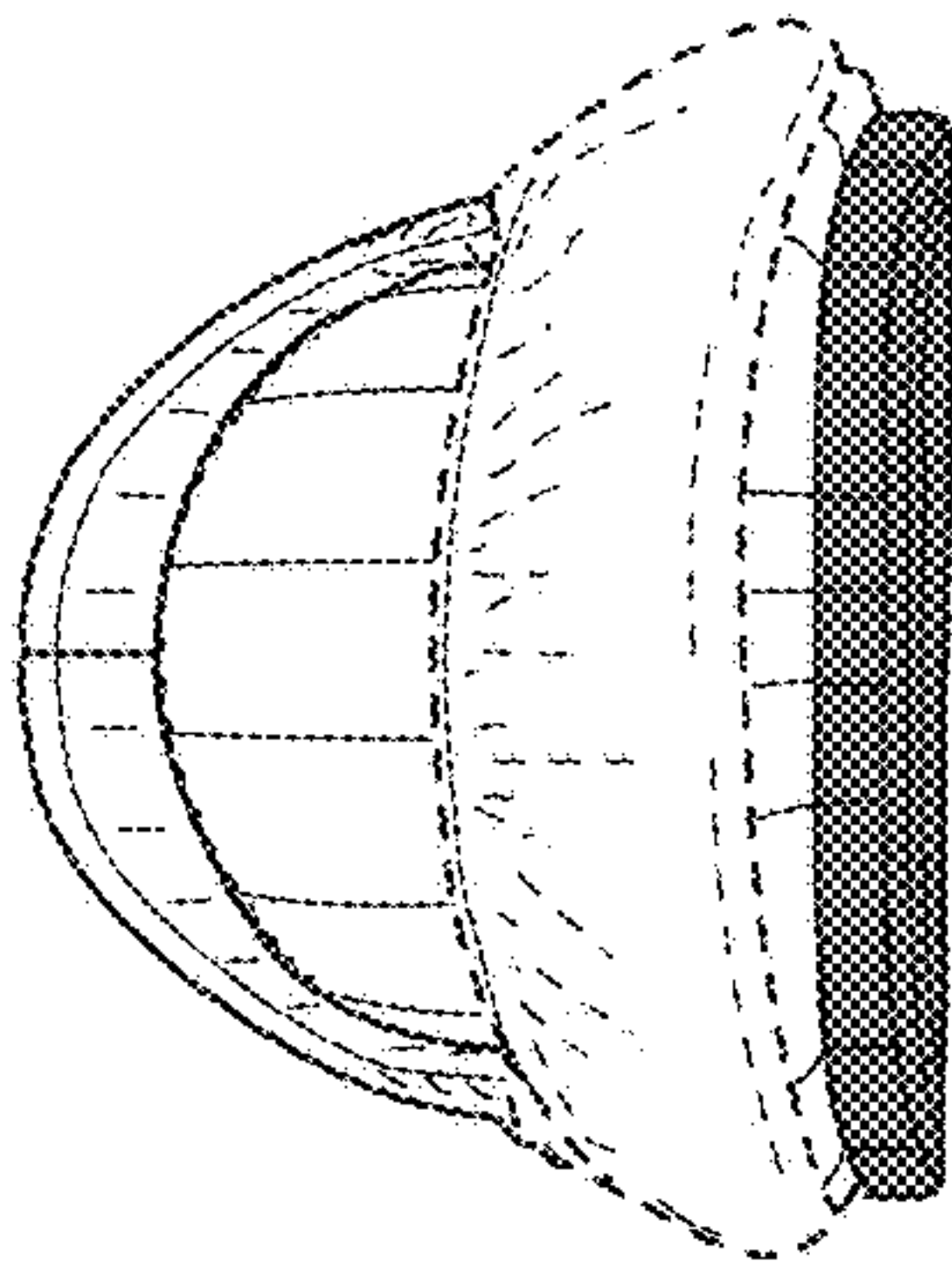

FIG. 90

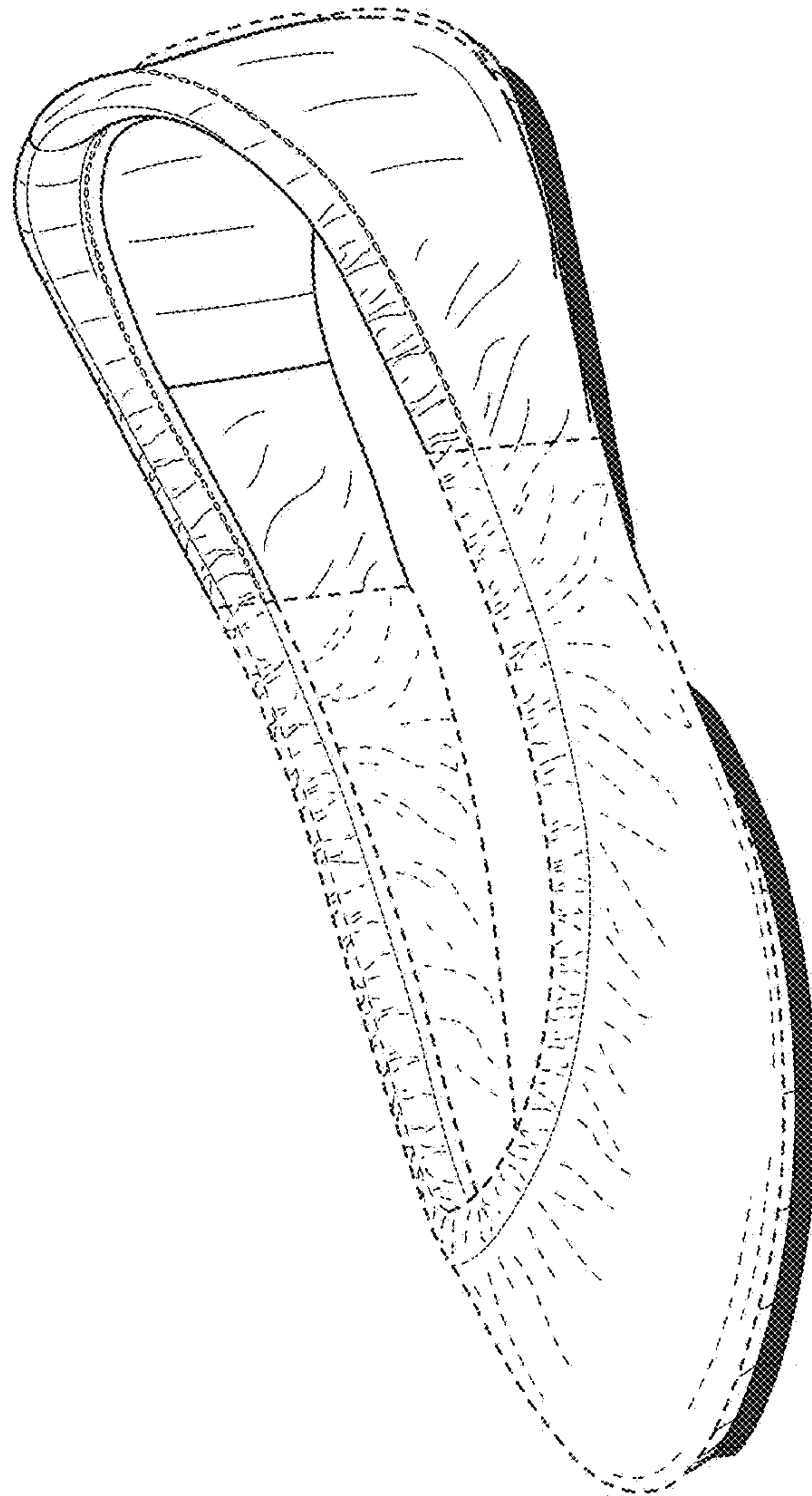

FIG. 92

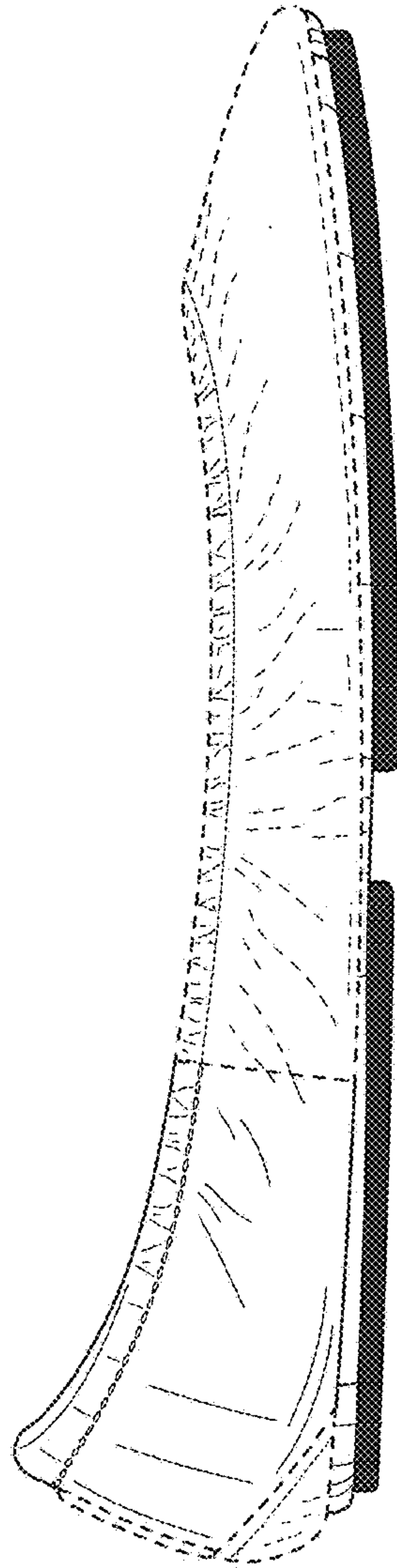

FIG. 93

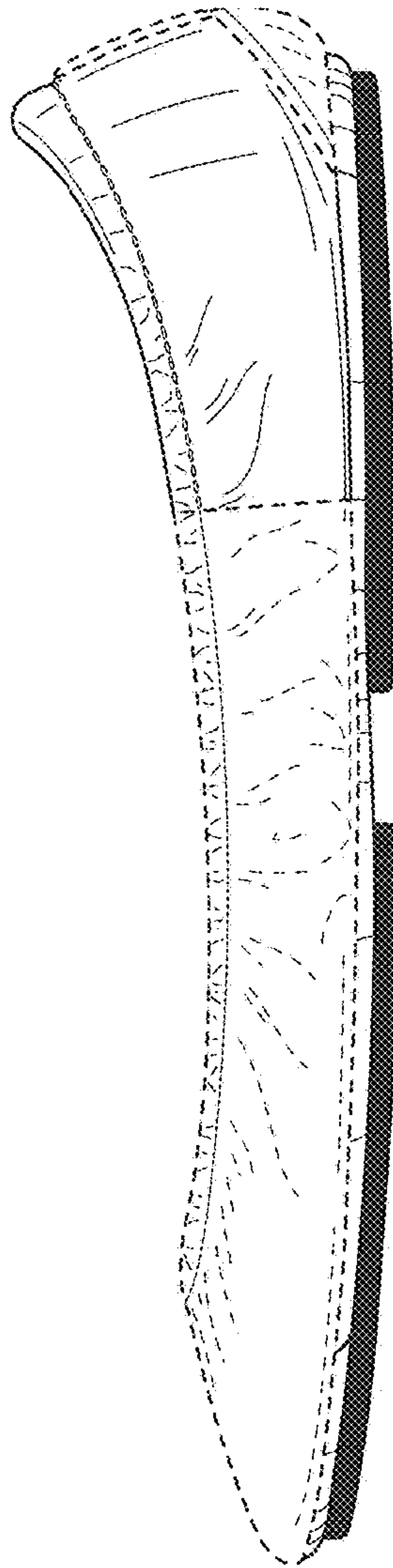

FIG. 94

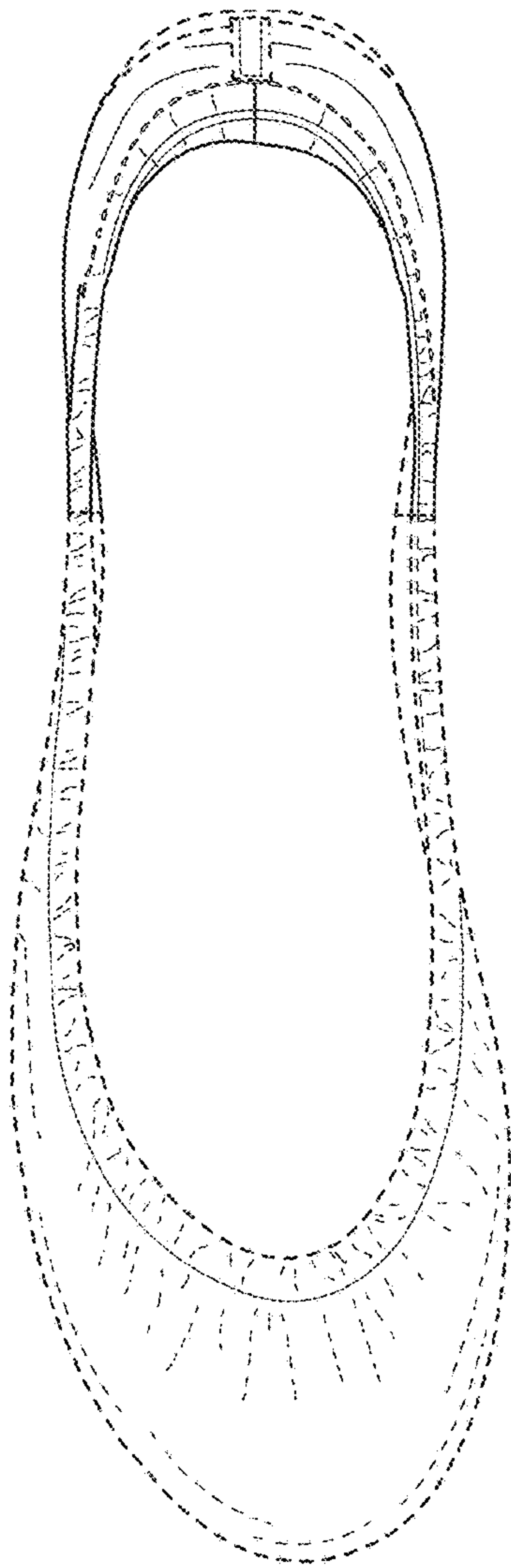

FIG. 95

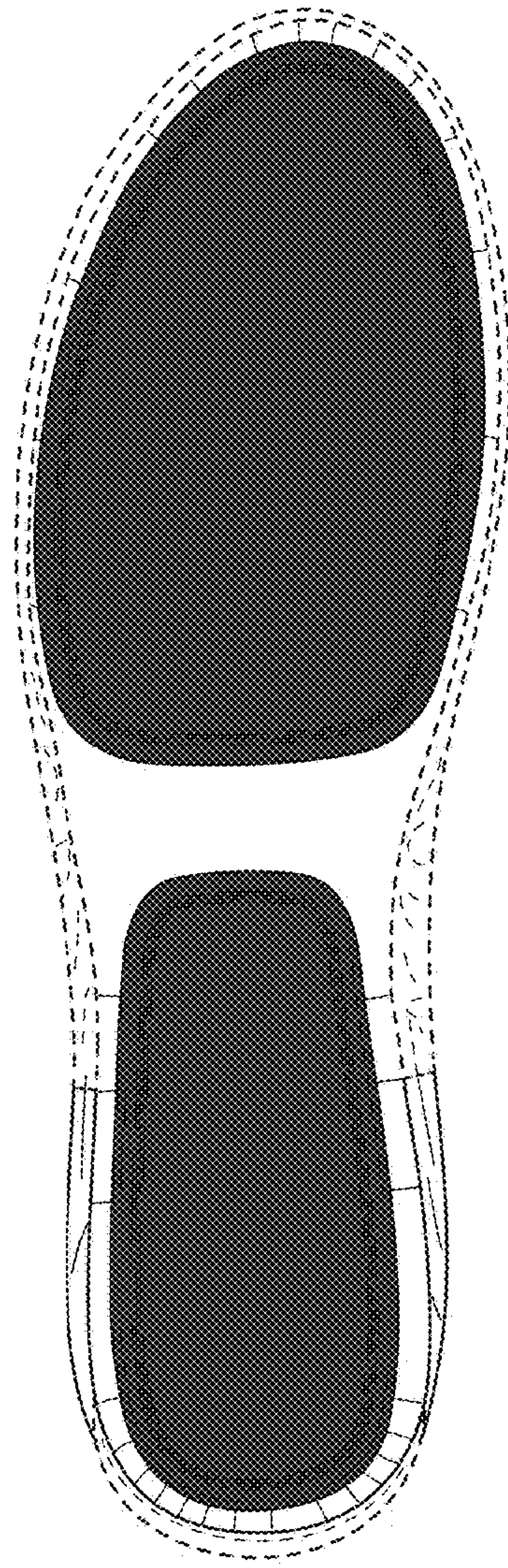

FIG. 96

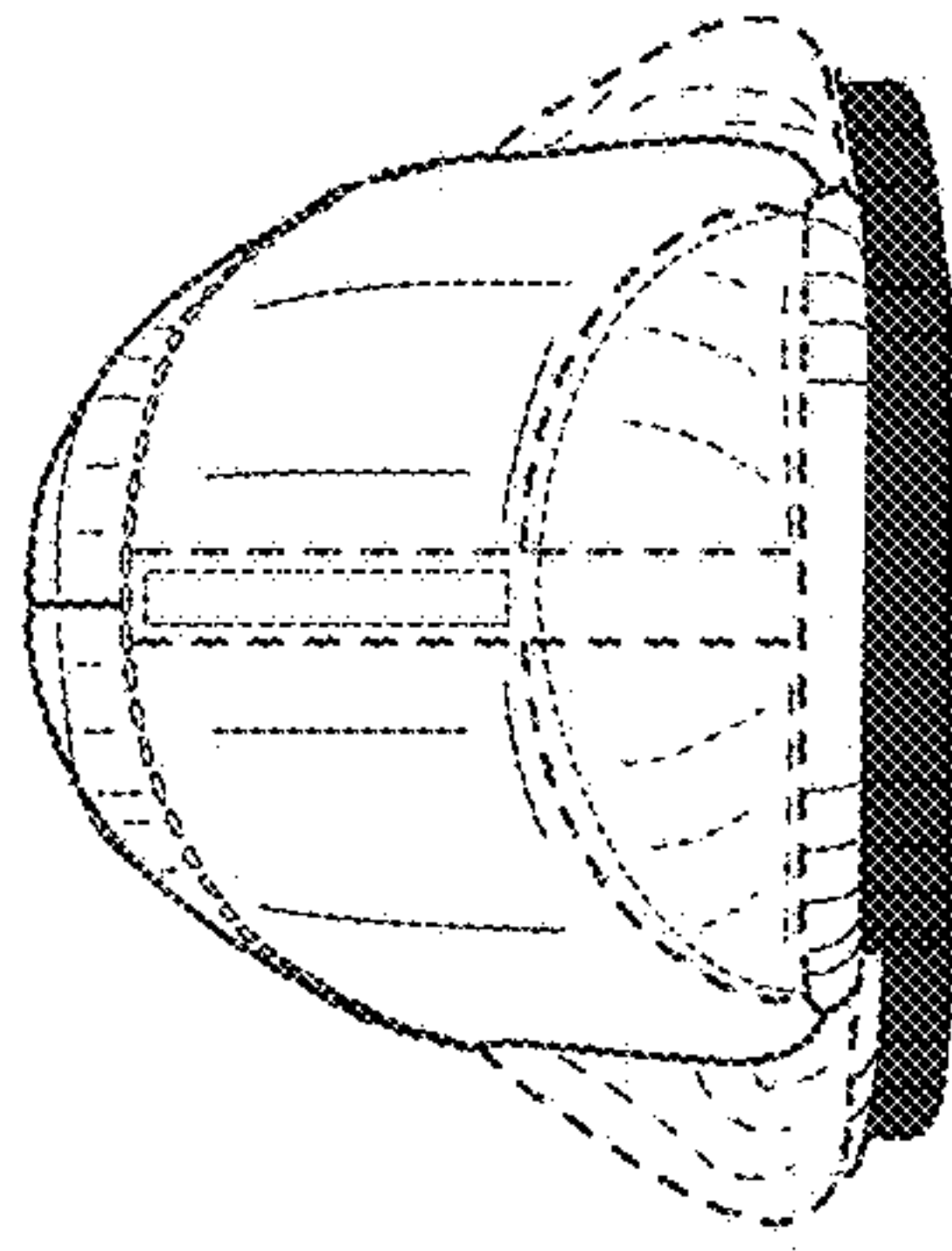

FIG. 97

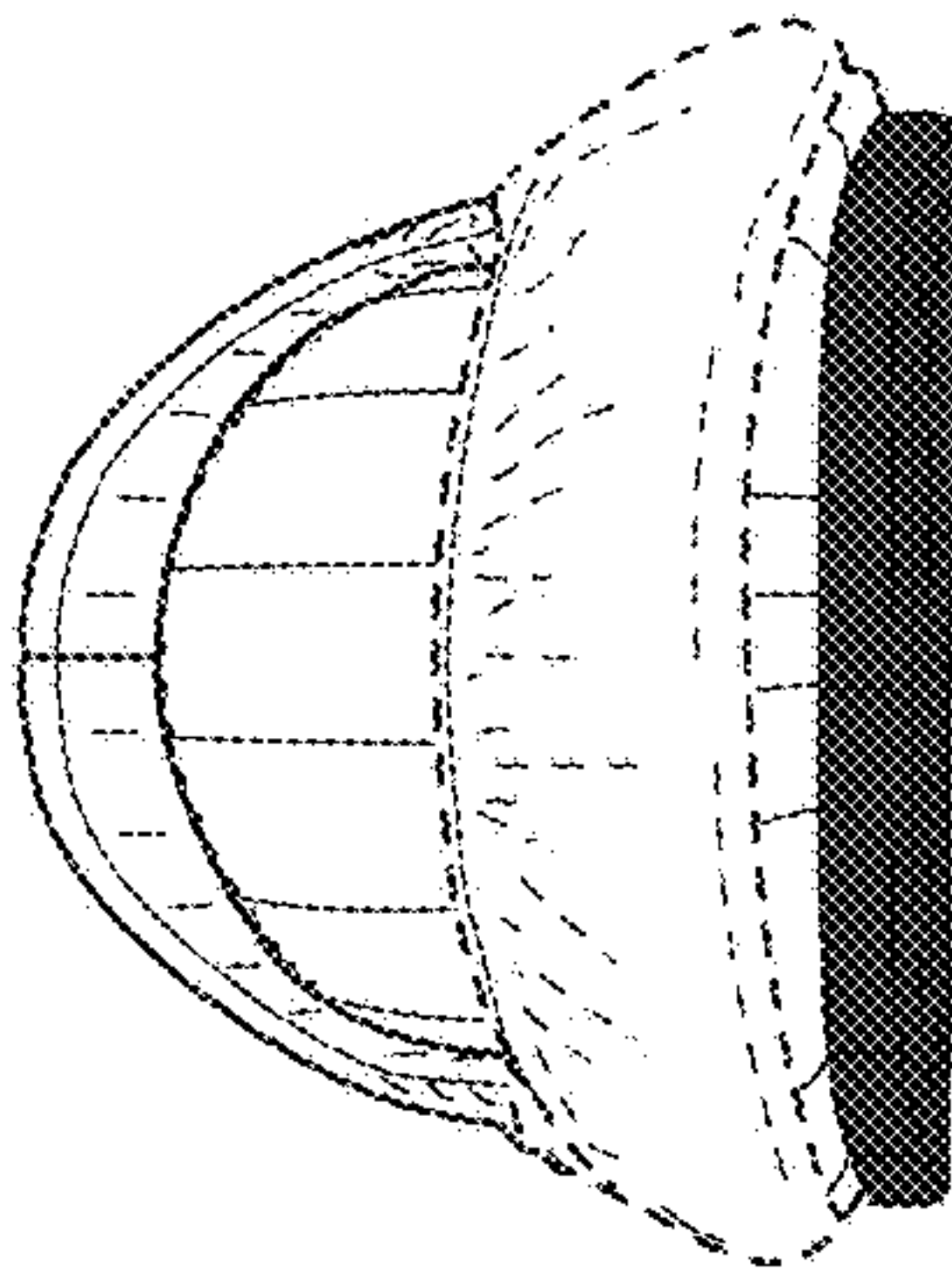

FIG. 98

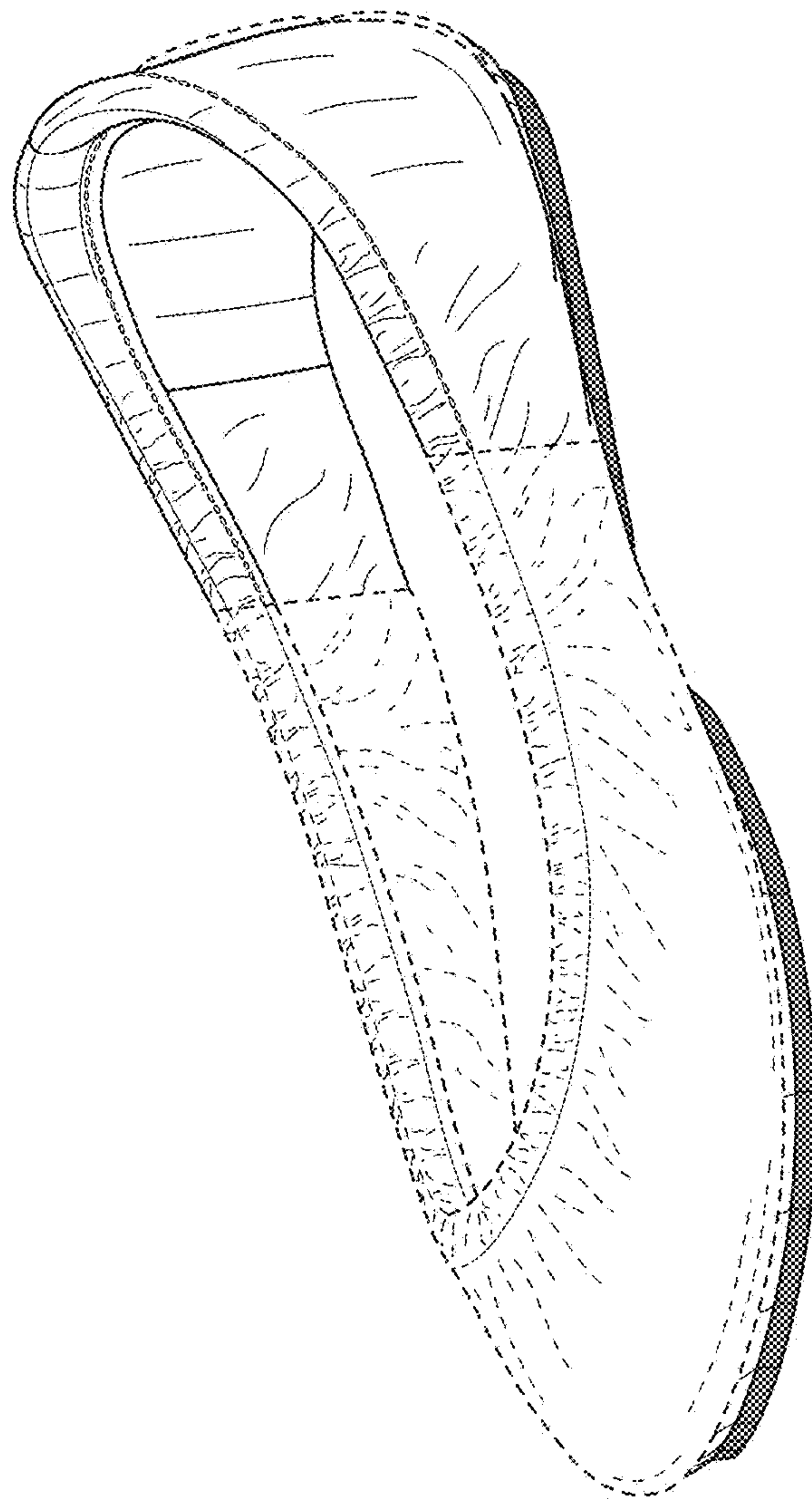

FIG. 99

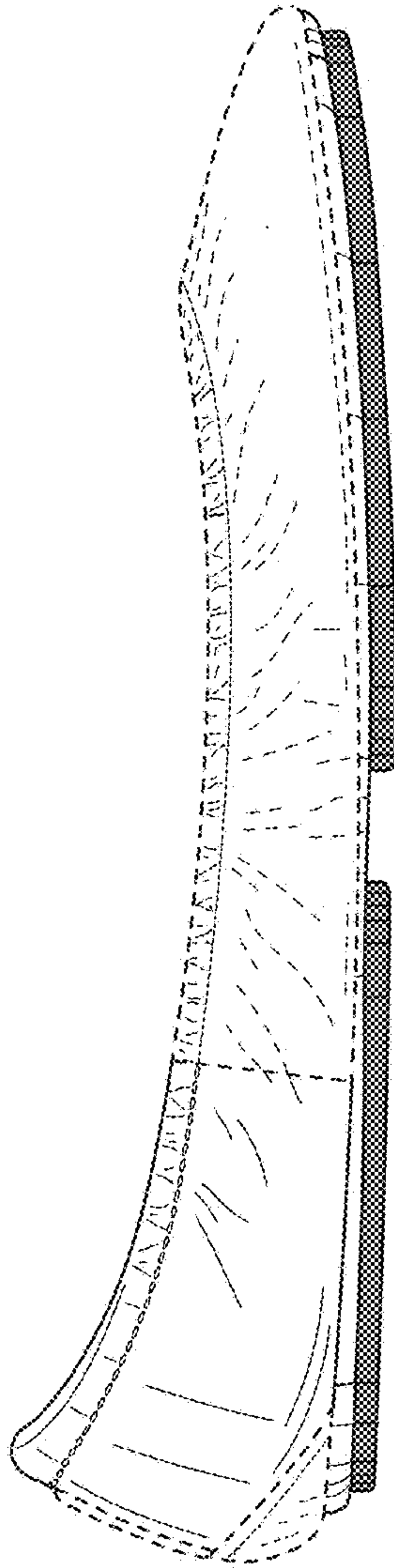

FIG. 100

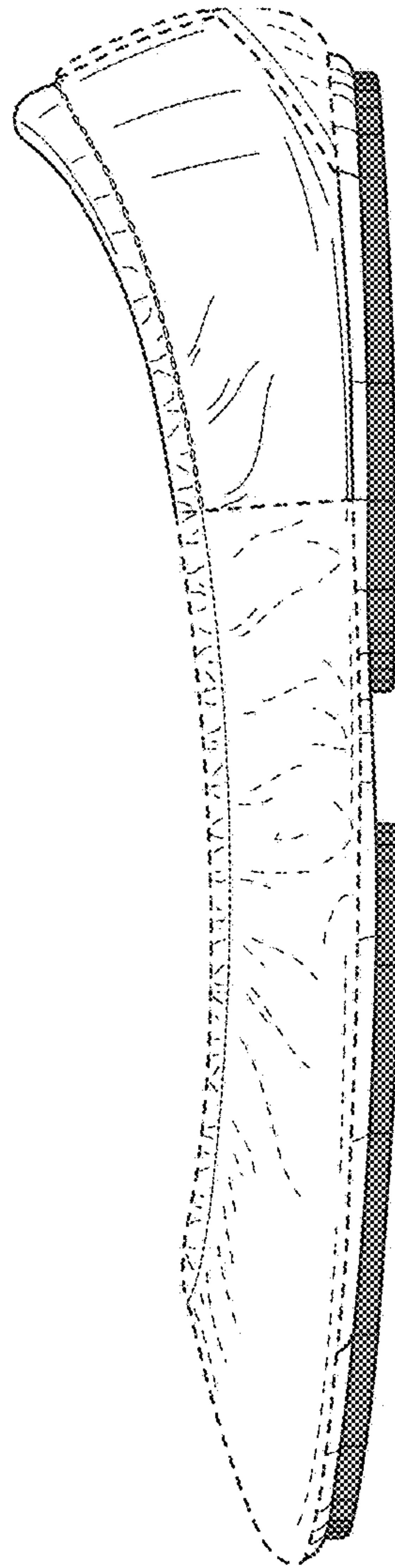

FIG. 101

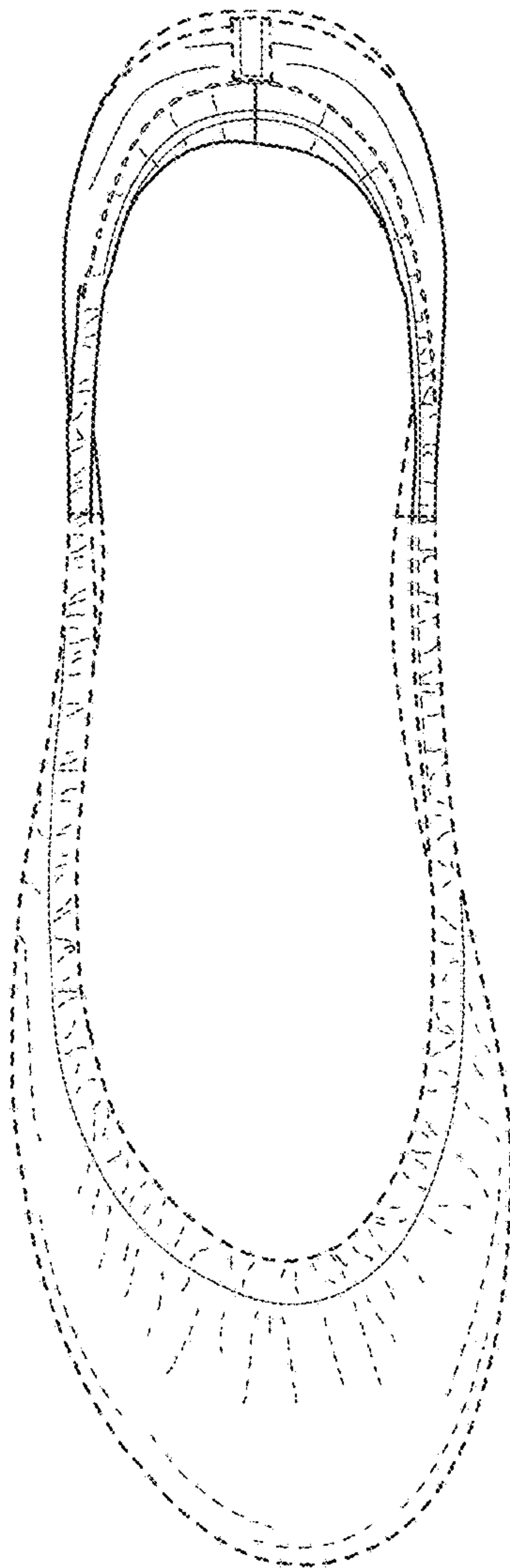

FIG. 102

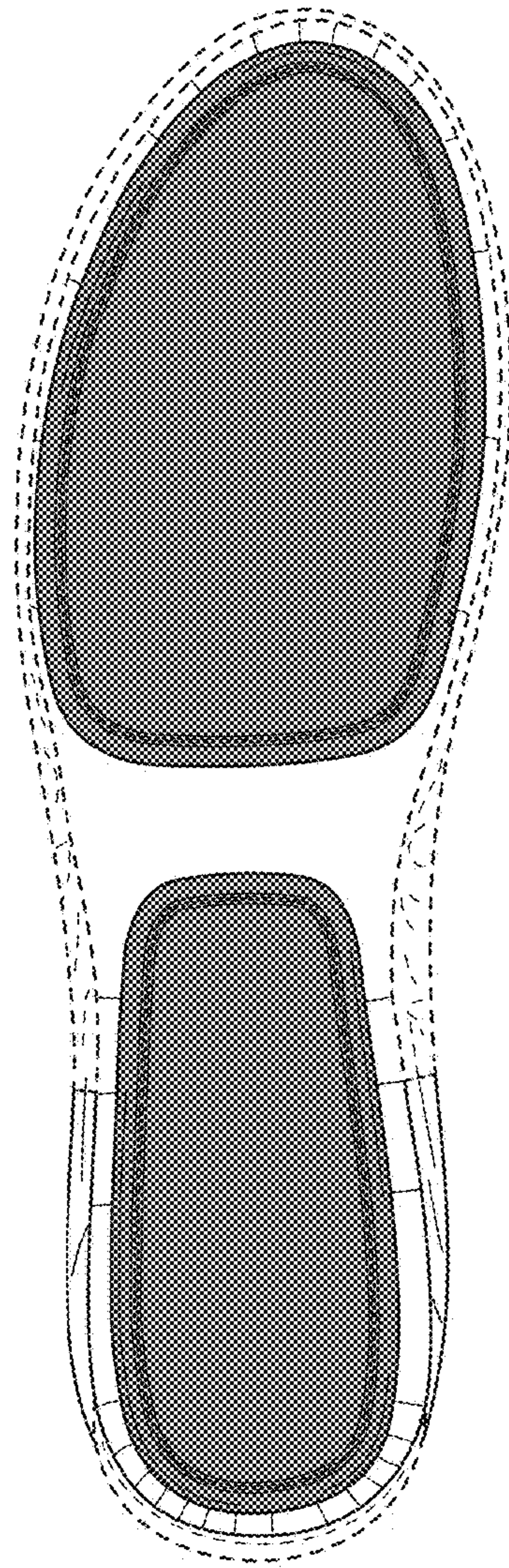

FIG. 103

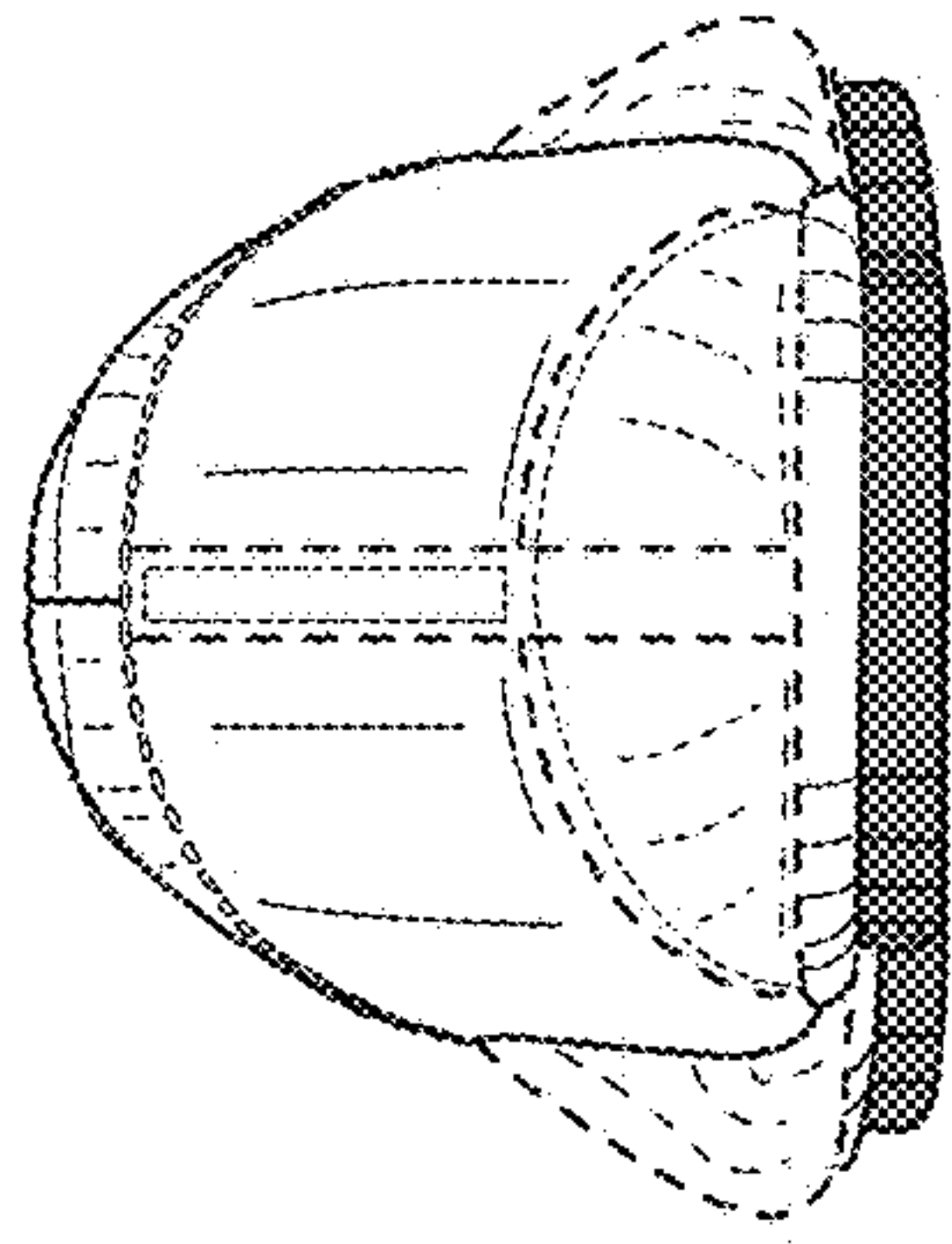

FIG. 105

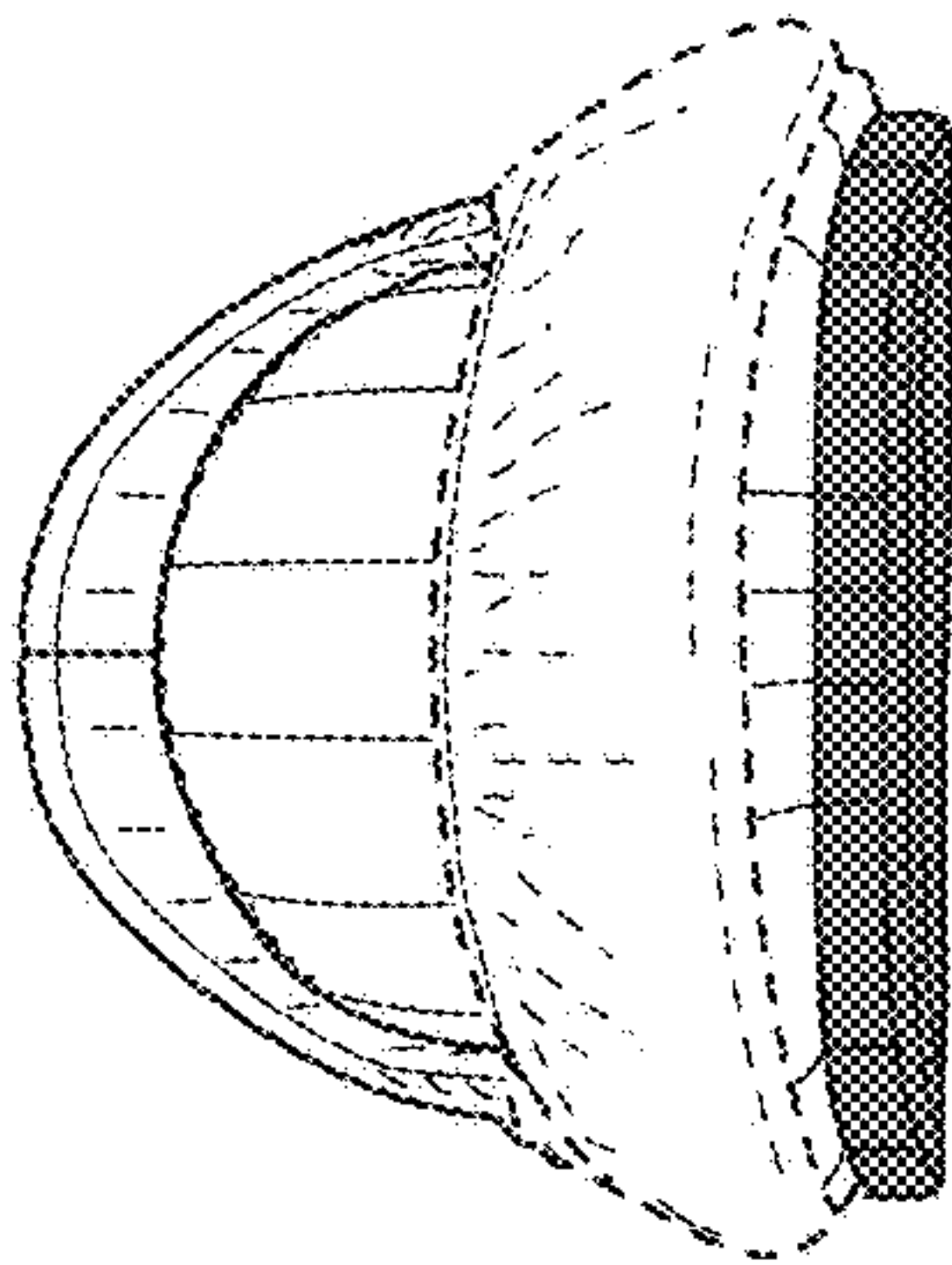

FIG. 104