



US00D846145S

(12) **United States Design Patent**
Williams et al.

(10) **Patent No.:** **US D846,145 S**

(45) **Date of Patent:** **** Apr. 16, 2019**

(54) **TEST CARTRIDGE BASE**

(71) Applicant: **FUNDAMENTAL SOLUTIONS CORPORATION**, Easton, PA (US)

(72) Inventors: **Marvin R. Williams**, Easton, PA (US);
Charles McBairty, Easton, PA (US);
Daniel W. Pfautz, Hatfield, PA (US);
Andrew Weiman, Langhorne, PA (US)

(73) Assignee: **Fundamental Solutions Corporation**, Easton, PA (US)

(**) Term: **15 Years**

(21) Appl. No.: **29/632,418**

(22) Filed: **Jan. 8, 2018**

(51) **LOC (11) Cl.** **24-02**

(52) **U.S. Cl.**
USPC **D24/224**

(58) **Field of Classification Search**
USPC D24/216, 224
CPC B01L 3/50; B01L 3/545; B01L 2200/185;
B01L 2300/021; B01L 2300/043; G01N
17/002; G01N 21/763; G01N 33/12;
G01N 33/025; G01N 35/00029; G01N
2001/005; G01N 2001/007; G01N
2035/00138

See application file for complete search history.

(56) **References Cited**

U.S. PATENT DOCUMENTS

D533,687 S *	12/2006	Bull	D30/118
D800,336 S *	10/2017	Chang	D24/224
D800,912 S *	10/2017	Uzri	D24/216
D806,890 S *	1/2018	Williams	D24/216
2004/0161855 A1 *	8/2004	Kvasnik	B01L 3/545 436/165

(Continued)

Primary Examiner — Antoine Duval Davis

(74) *Attorney, Agent, or Firm* — Frost Brown Todd LLC

(57) **CLAIM**

The ornamental design for a test cartridge base, as shown and described.

DESCRIPTION

FIG. 1 is a top, front perspective view of a test cartridge base;

FIG. 2 is a top, rear perspective view of the test cartridge base of FIG. 1;

FIG. 3 is a bottom, rear perspective view of the test cartridge base of FIG. 1;

FIG. 4 is a top view of the test cartridge base of FIG. 1;

FIG. 5 is a bottom view of the test cartridge base of FIG. 1;

FIG. 6 is a left-side view of the test cartridge base of FIG. 1;

FIG. 7 is a right-side view of the test cartridge base of FIG. 1;

FIG. 8 is a front view of the test cartridge base of FIG. 1;

FIG. 9 is a rear view of the test cartridge base of FIG. 1;

FIG. 10 is a top, front perspective view of the test cartridge base of FIG. 1, wherein a test cartridge has been fully inserted into the test cartridge base;

FIG. 11 is a top, rear perspective view of the test cartridge base of FIG. 1, wherein a test cartridge has been fully inserted into the test cartridge base;

FIG. 12 is a top view of the test cartridge base of FIG. 1, wherein a test cartridge has been fully inserted into the test cartridge base;

FIG. 13 is a bottom view of the test cartridge base of FIG. 1, wherein a test cartridge has been fully inserted into the test cartridge base; and,

FIG. 14 is a front view of the test cartridge base of FIG. 1, wherein a test cartridge has been fully inserted into the test cartridge base.

The broken lines showing the test cartridge in FIGS. 10-14 represent environmental subject matter; the broken lines form no part of the claimed design.

1 Claim, 5 Drawing Sheets

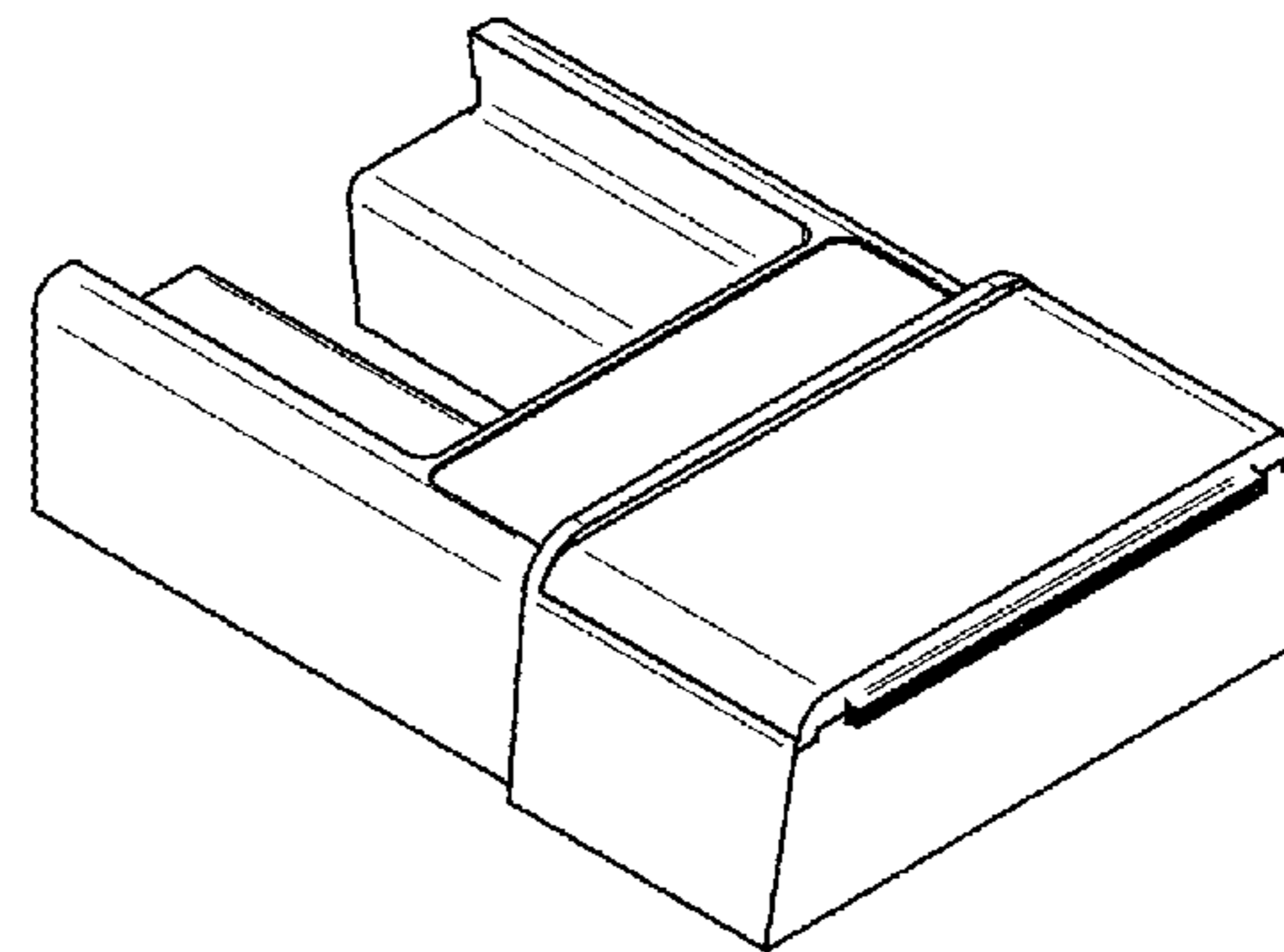
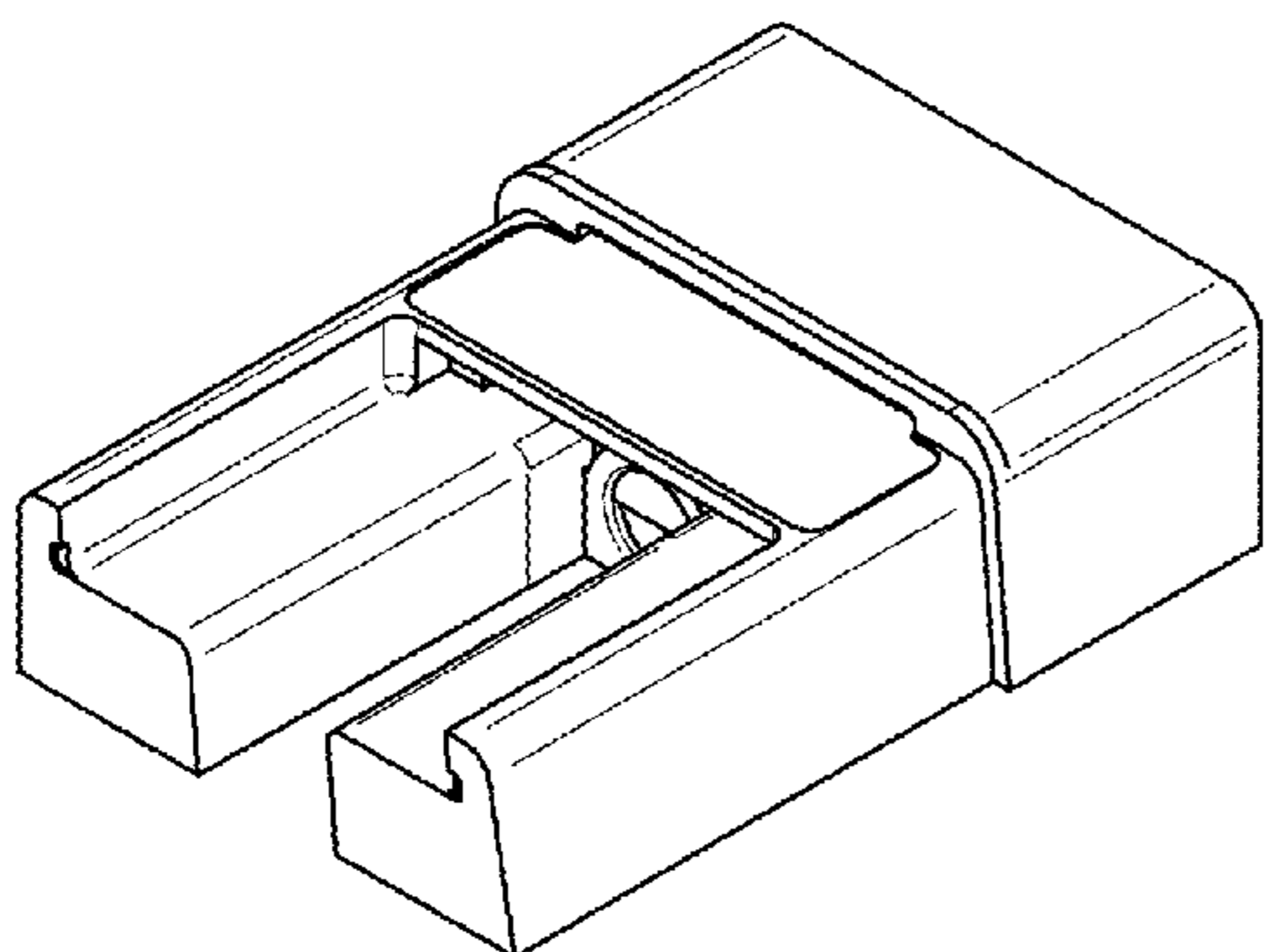

(56)

References Cited

U.S. PATENT DOCUMENTS

2014/0021756 A1* 1/2014 Gudel Kemm A47D 1/00
297/250.1
2018/0066300 A1* 3/2018 Williams B01L 3/502

* cited by examiner

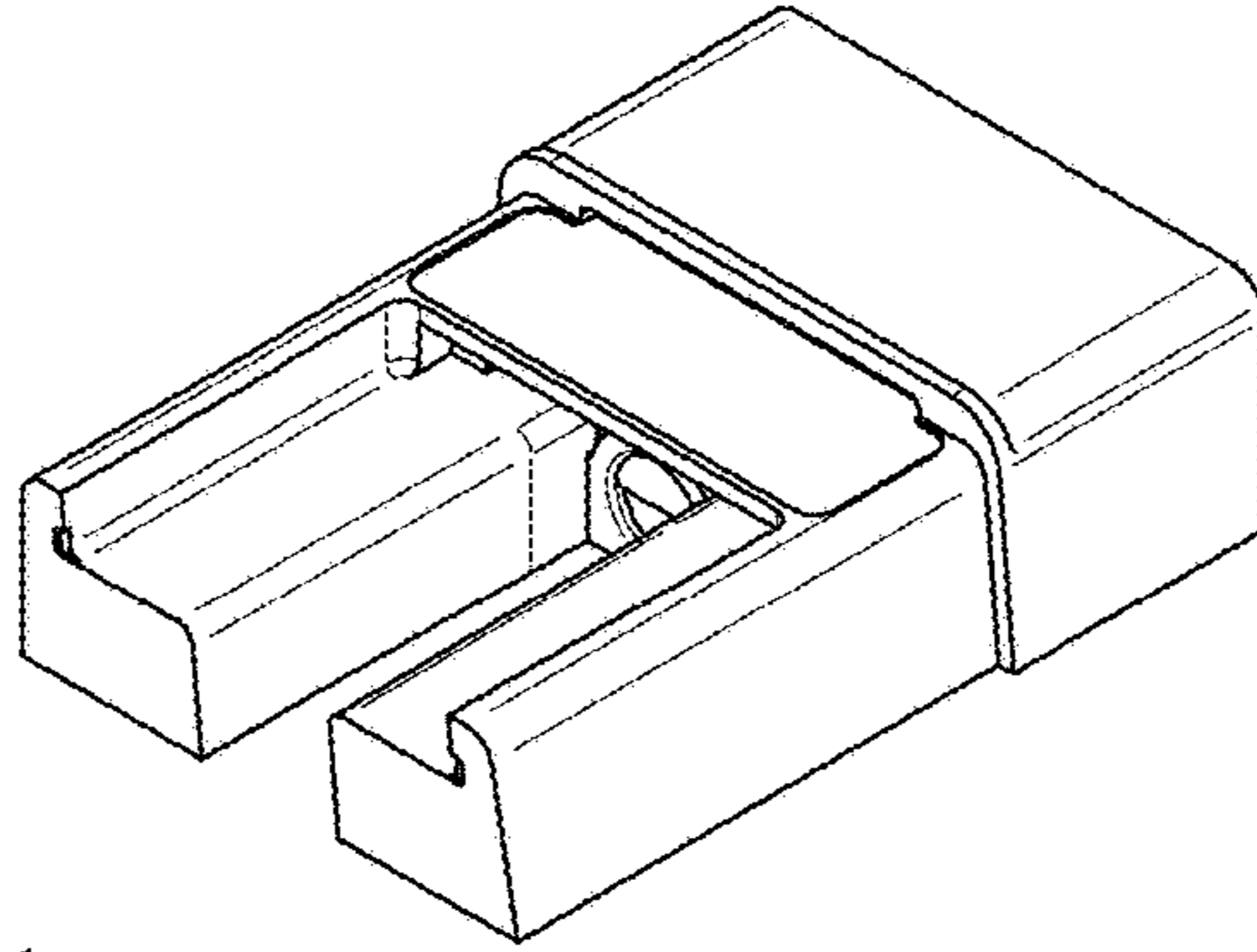

FIG. 1

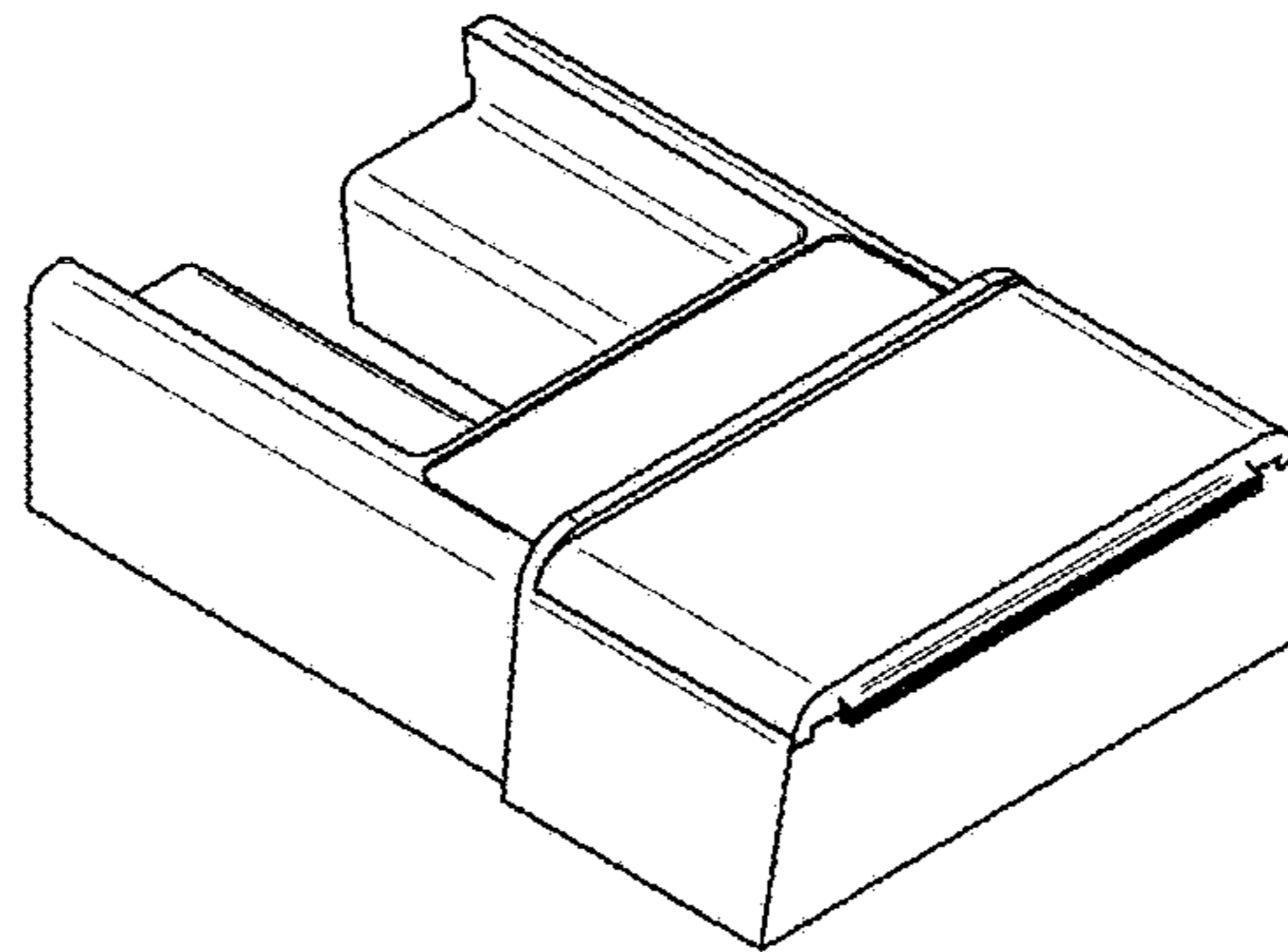

FIG. 2

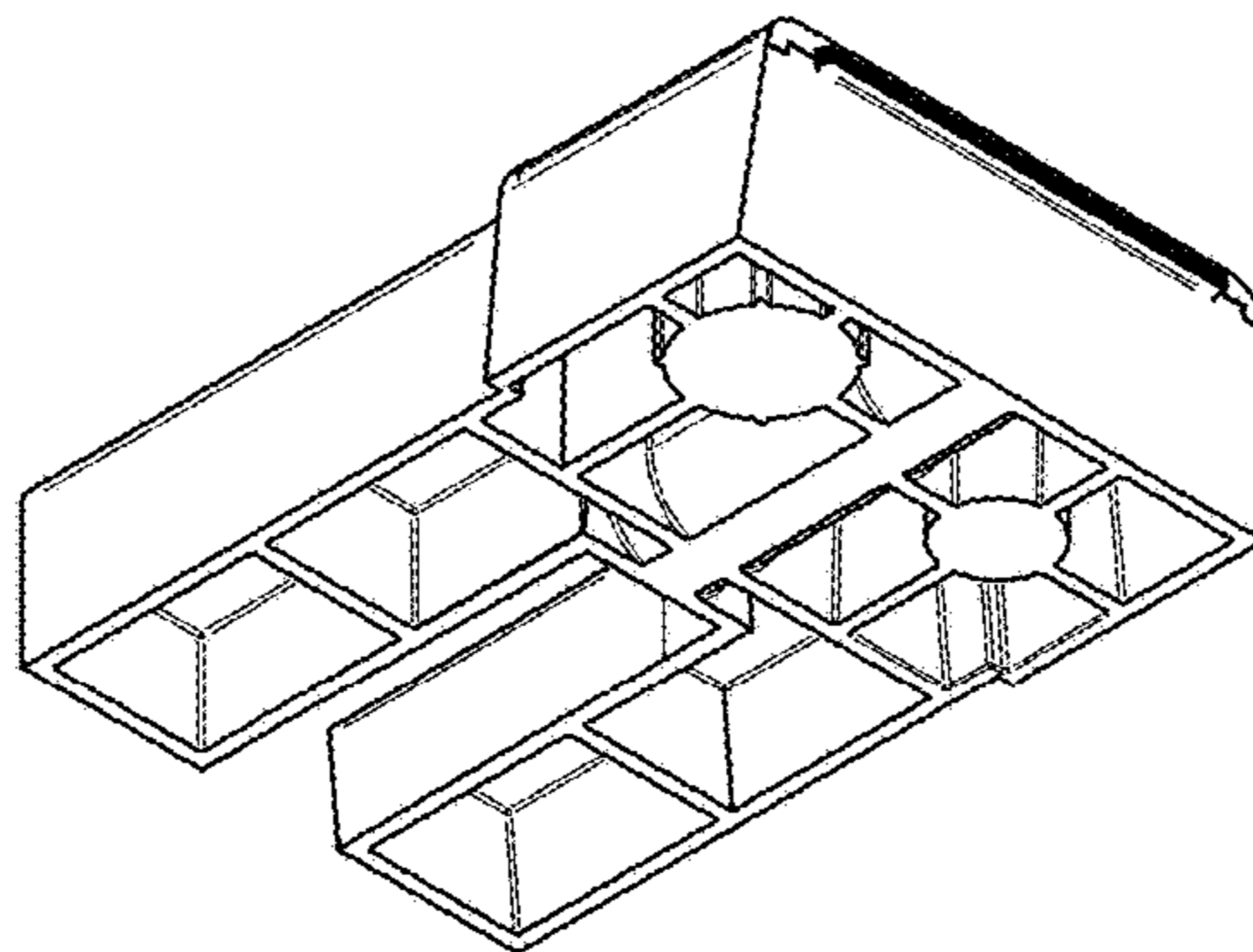

FIG. 3

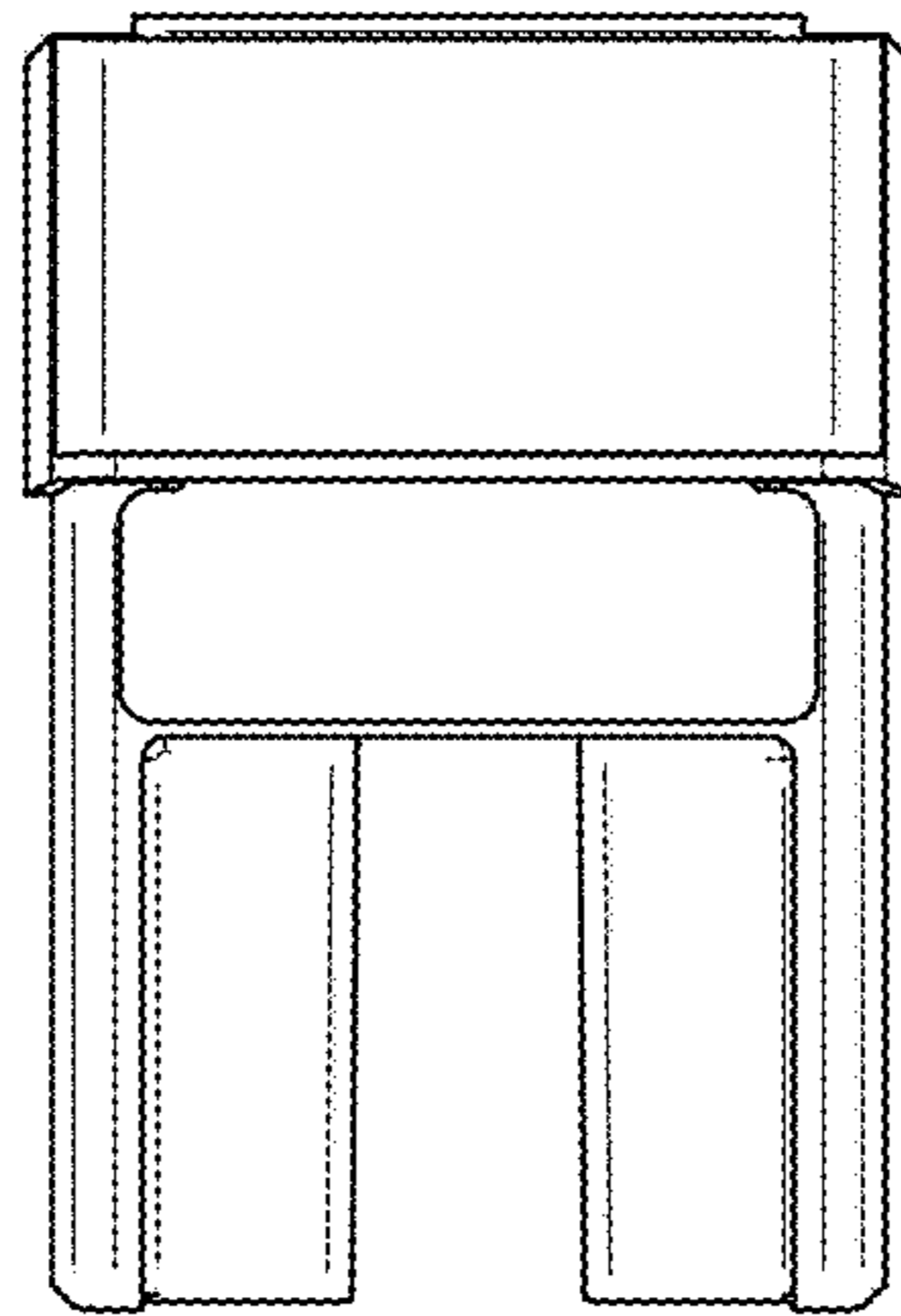

FIG. 4

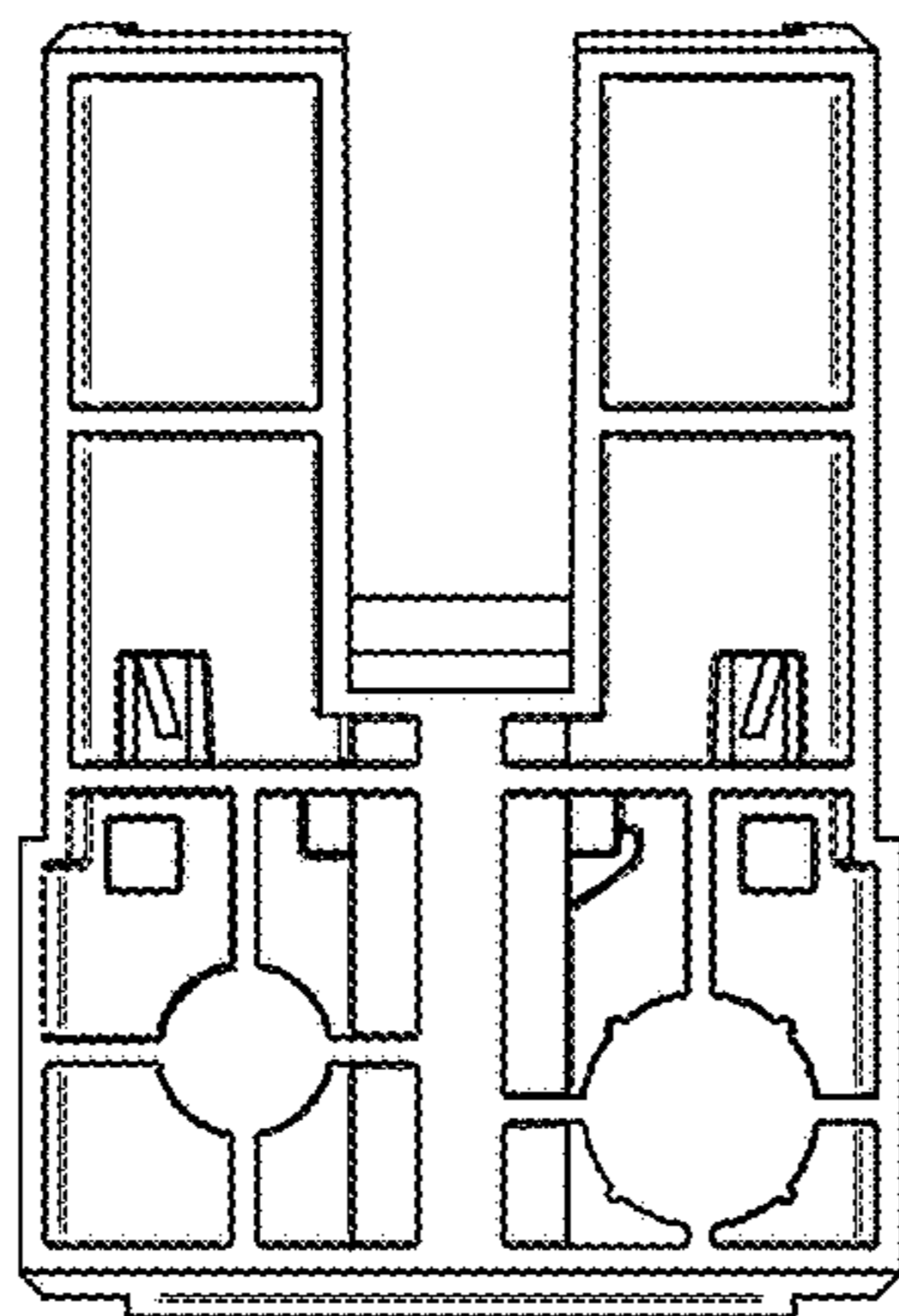

FIG. 5

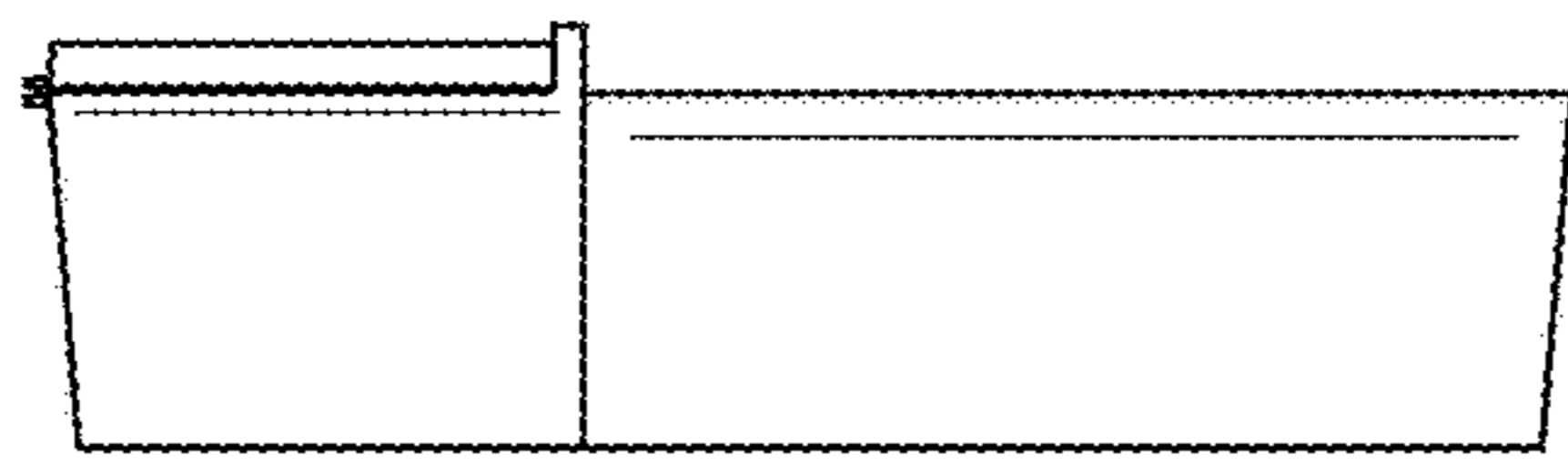

FIG. 6

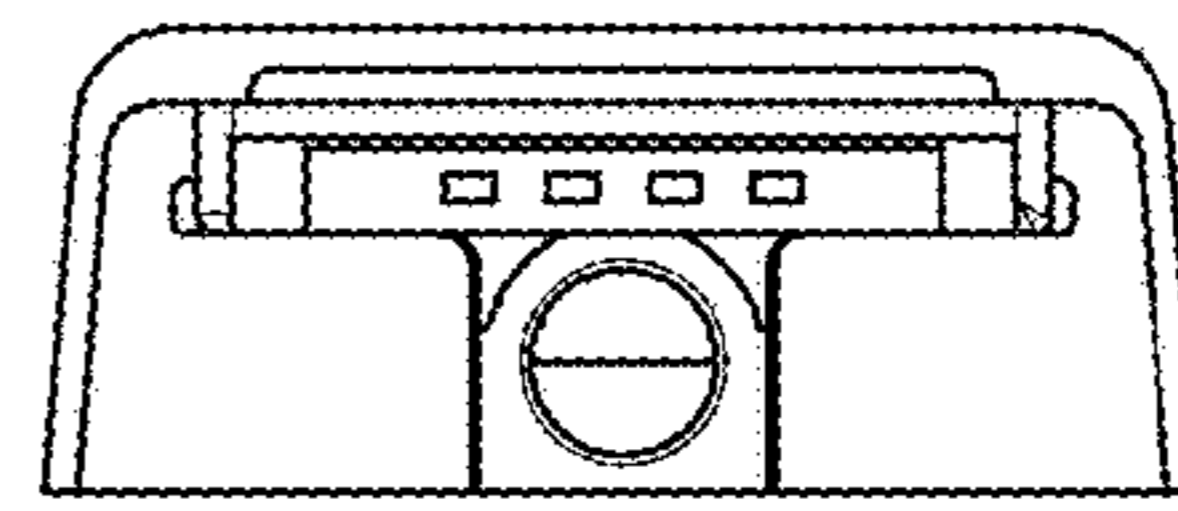

FIG. 8

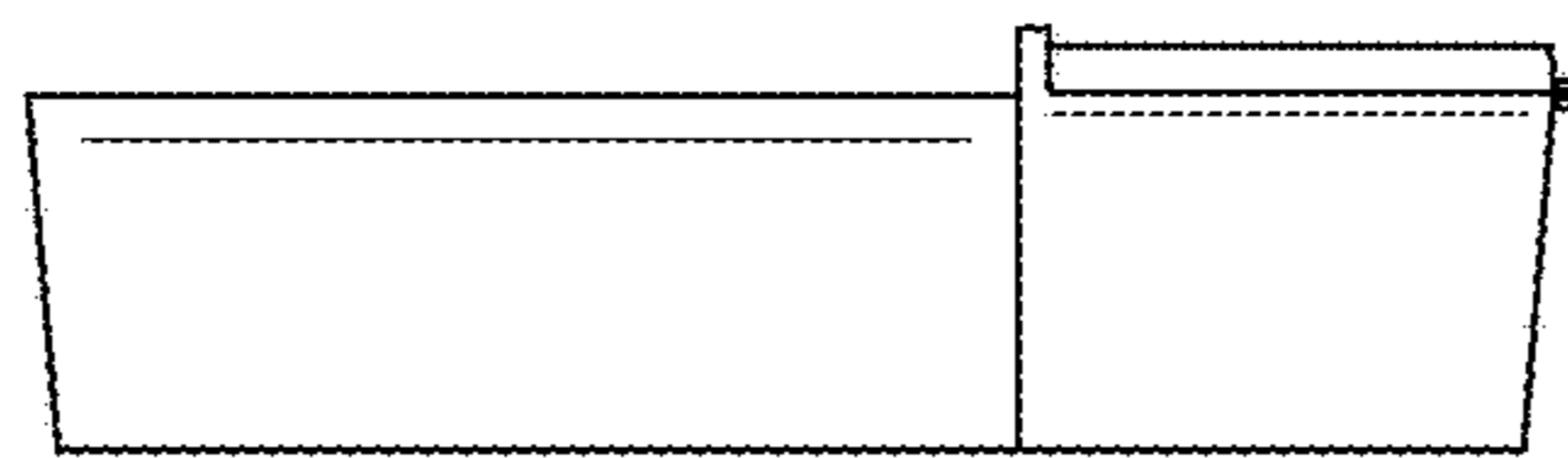

FIG. 7



FIG. 9

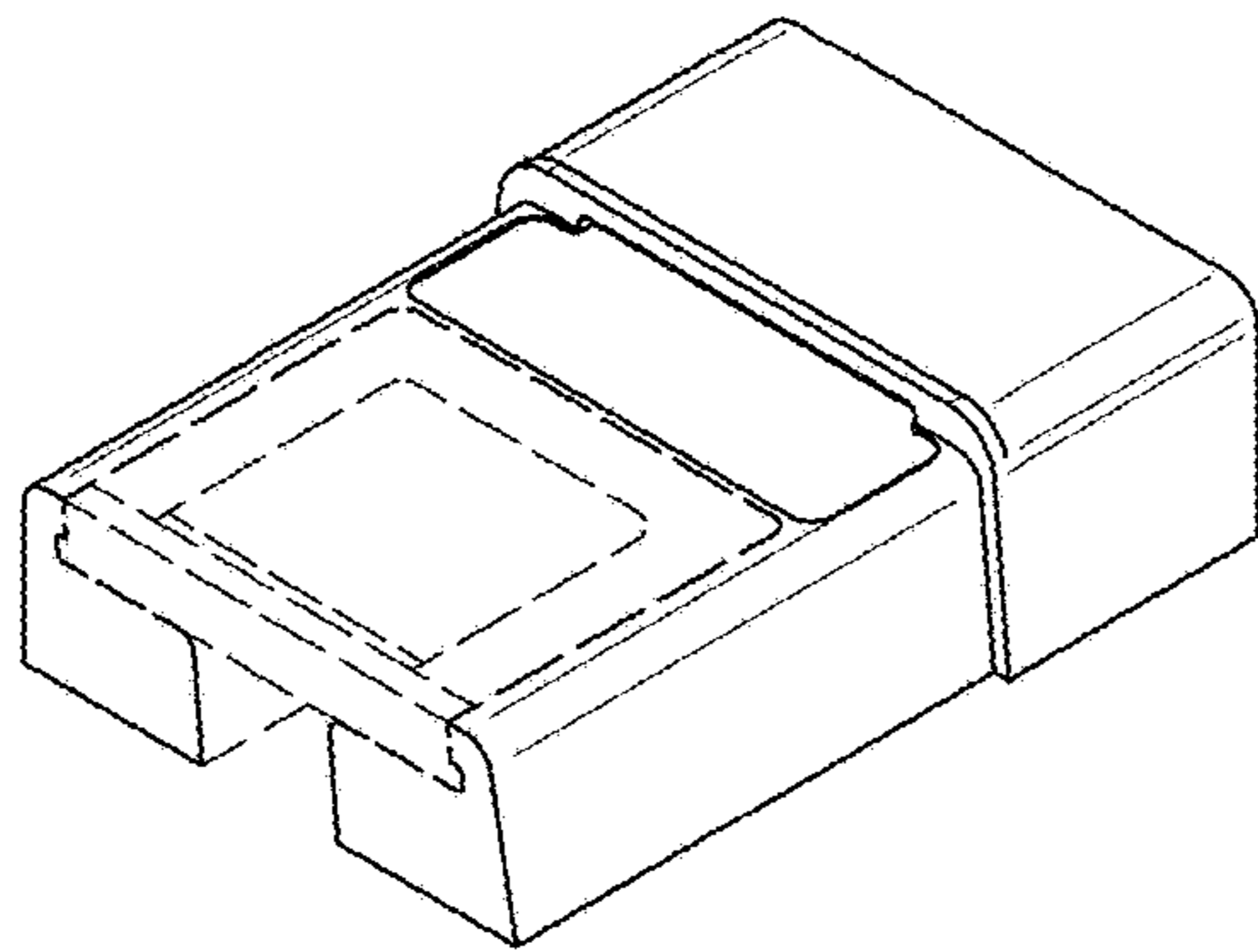

FIG. 10

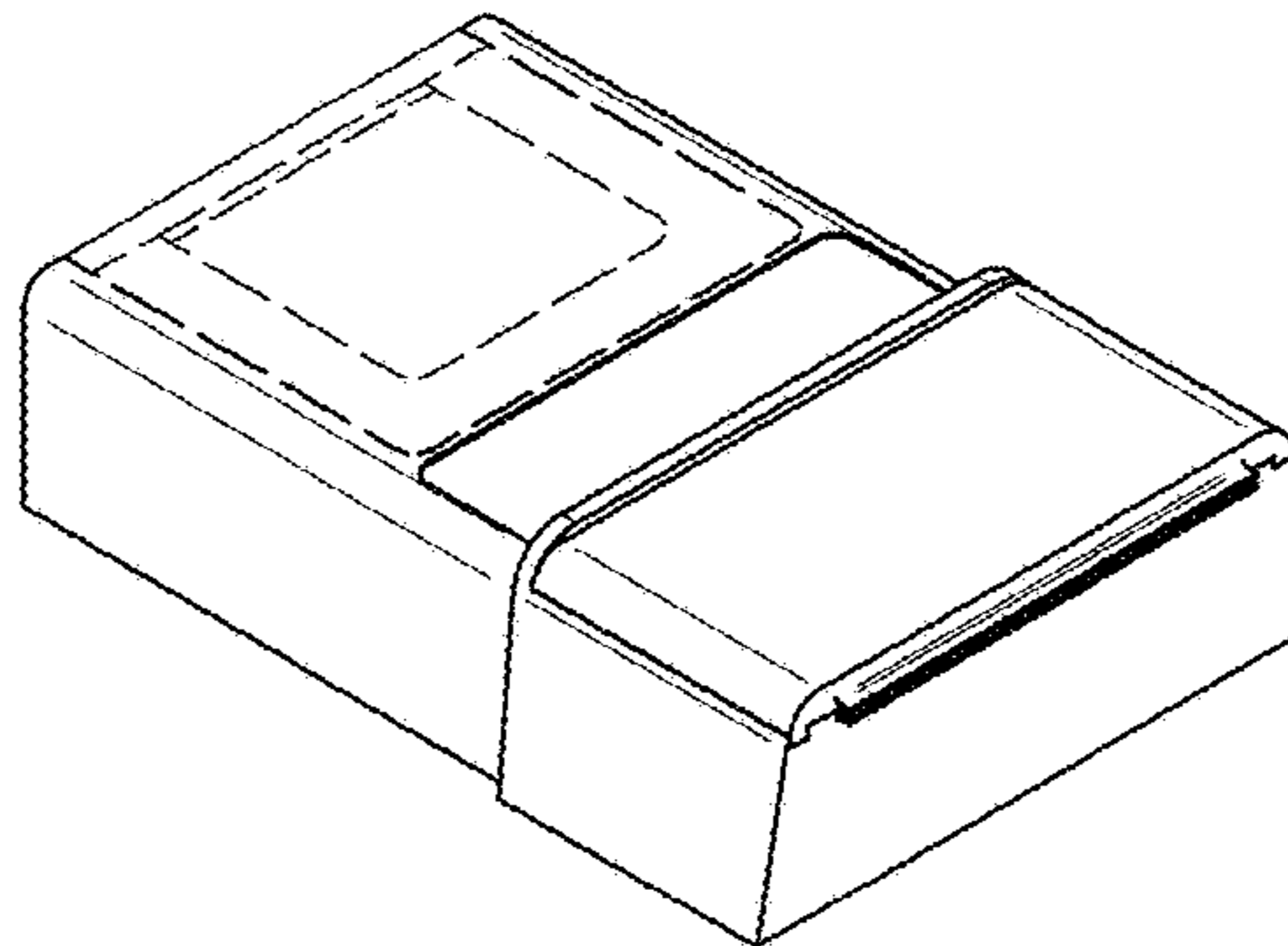

FIG. 11

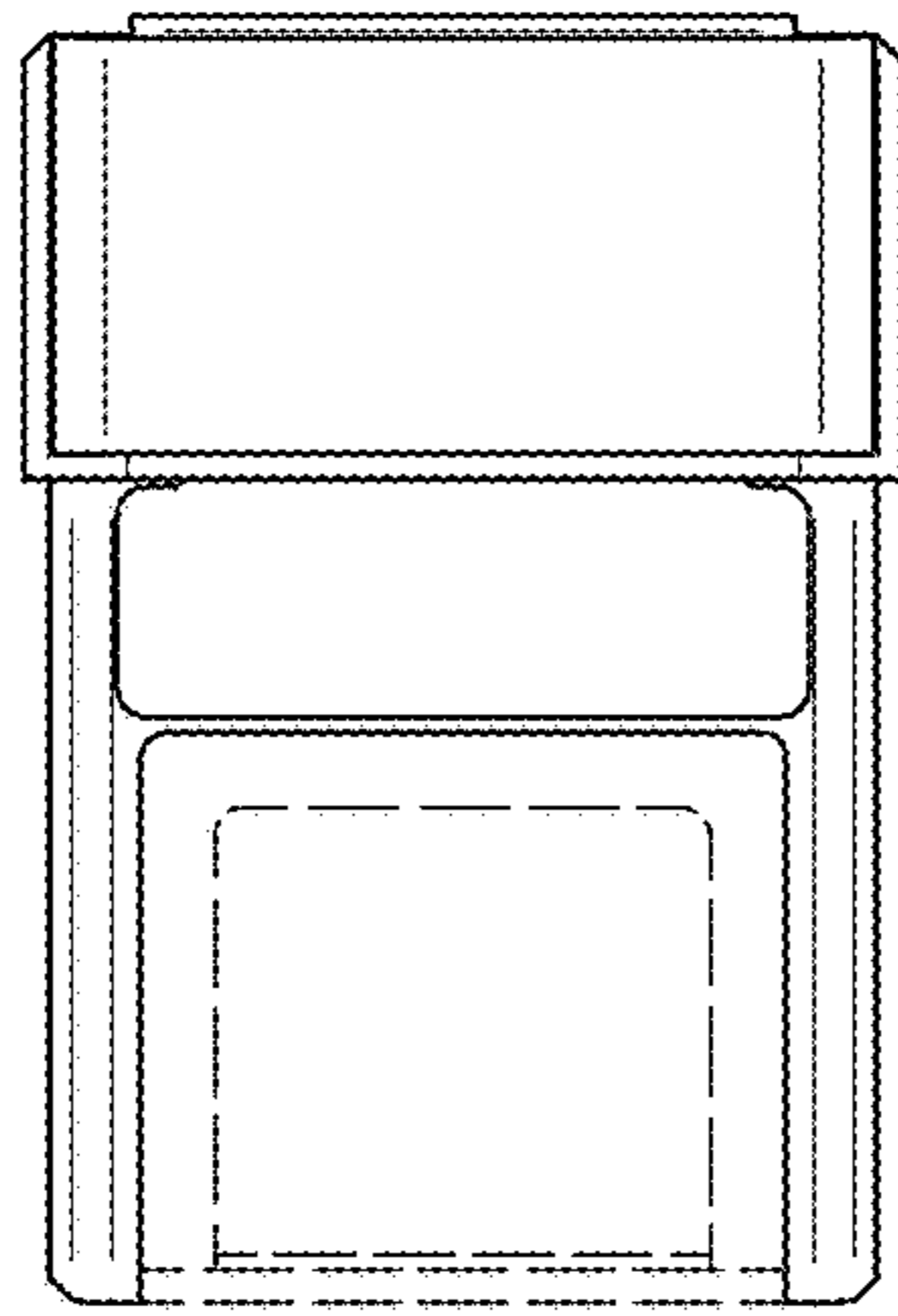

FIG. 12

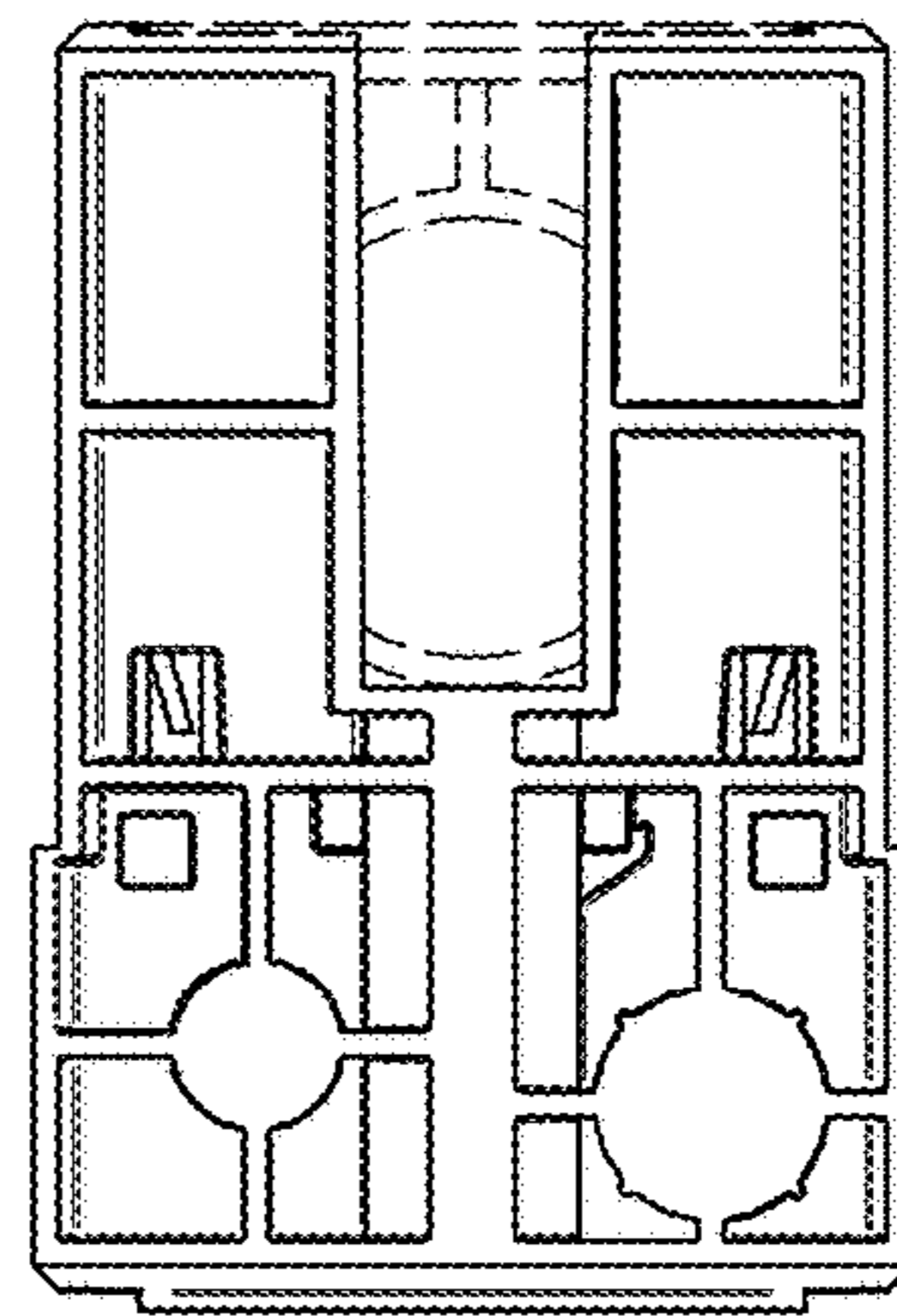

FIG. 13

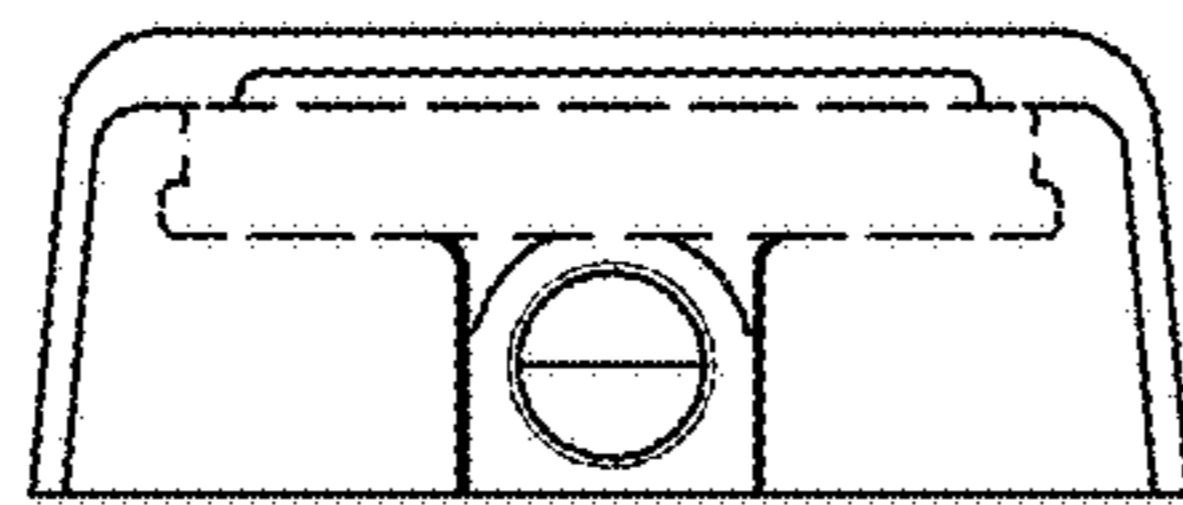

FIG. 14