



US00D846143S

(12) **United States Design Patent**
Ito

(10) **Patent No.:** **US D846,143 S**
(45) **Date of Patent:** **** Apr. 16, 2019**

(54) **COMBINED CELL TRANSFER NOZZLE AND PIPETTE TIP FOR CELL CLUSTERING**

(71) Applicant: **Saburo Ito**, Shizuoka-ken (JP)

(72) Inventor: **Saburo Ito**, Shizuoka-ken (JP)

(73) Assignee: **YAMAHA HATSUDOKI KABUSHIKI KAISHA** (JP)

(**) Term: **15 Years**

(21) Appl. No.: **29/546,884**

(22) Filed: **Nov. 27, 2015**

(30) **Foreign Application Priority Data**

May 28, 2015 (JP) 2015-011785
May 28, 2015 (JP) 2015-011786

(Continued)

(51) **LOC (11) Cl.** **24-02**

(52) **U.S. Cl.**
USPC **D24/222**

(58) **Field of Classification Search**
USPC D24/107, 121, 133, 216, 222-230, 233;
D9/523, 547, 549, 550, 724, 732

(Continued)

(56) **References Cited**

U.S. PATENT DOCUMENTS

D257,567 S * 11/1980 Peacock D24/114
D373,827 S * 9/1996 Polaniec D24/112

(Continued)

Primary Examiner — Vy N Koenig

(74) *Attorney, Agent, or Firm* — Ostrolenk Faber LLP

(57) **CLAIM**

The ornamental design for a combined cell transfer nozzle and pipette tip for cell clustering, as shown and described.

DESCRIPTION

FIG. 1 is a front perspective view of a combined cell transfer nozzle and pipette tip for cell clustering showing a first embodiment of my new design;

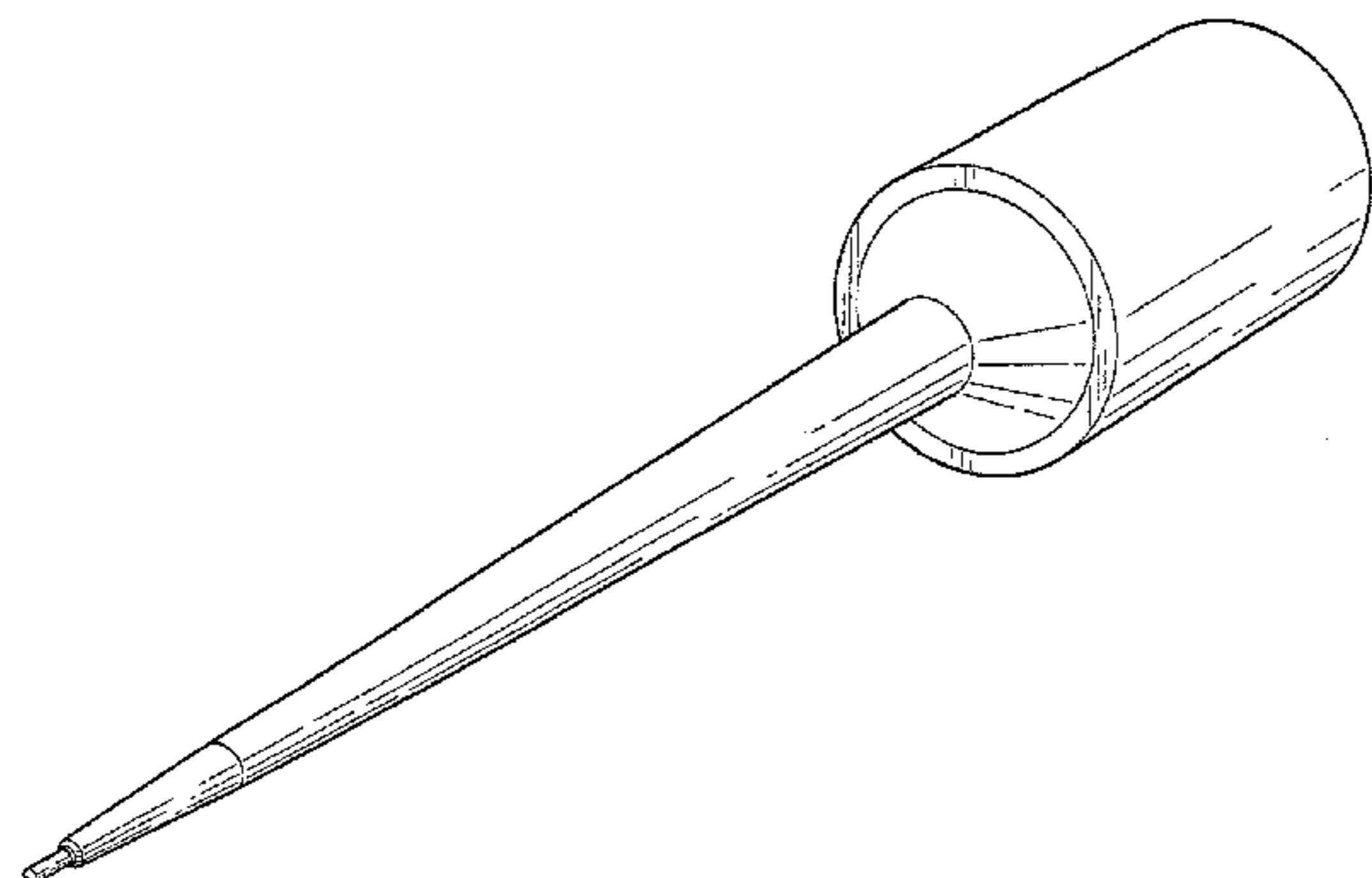

FIG. 2 is a side view thereof, wherein the view from every lateral side thereof is identical;

FIG. 3 is a front end view thereof;

FIG. 4 is a rear end view thereof;

FIG. 5 is a cross-sectional view thereof along line 5-5 in FIG. 2;

FIG. 6 is an enlarged fragmentary side view thereof of fragment 6-6 in FIG. 2, wherein the view from every lateral side thereof is identical;

FIG. 7 is an end view of fragment 6-6 in FIG. 2;

FIG. 8 is a front perspective view of fragment 6-6 in FIG. 2; FIG. 9 is a front perspective view of the first embodiment showing an alternate condition of the first embodiment of my new design;

FIG. 10 is a cross-sectional view thereof along line 10-10 in FIG. 9;

FIG. 11 is an enlarged fragmentary front perspective view of fragment 11-11 in the same alternate configuration as in FIG. 9;

FIG. 12 is a front perspective view of a combined cell transfer nozzle and pipette tip for cell clustering showing a second embodiment of my new design;

FIG. 13 is a side view thereof, wherein the view from every side thereof is identical;

FIG. 14 is a front end view thereof;

FIG. 15 is a rear end view thereof;

FIG. 16 is a cross-sectional view thereof along line 16-16 in FIG. 13;

FIG. 17 is an enlarged fragmentary side view thereof of fragment 17-17 in FIG. 13, wherein the view from every side thereof is identical;

FIG. 18 is an end view of the fragment in FIG. 17;

FIG. 19 is a front perspective view of the fragment in FIG. 17;

FIG. 20 is a front perspective view of the second embodiment showing an alternate condition of the second embodiment of my new design;

FIG. 21 is a cross-sectional view thereof along line 21-21 in FIG. 20; and,

FIG. 22 is an enlarged fragmentary front perspective view of fragment 22-22 in the same alternate configuration of the

(Continued)

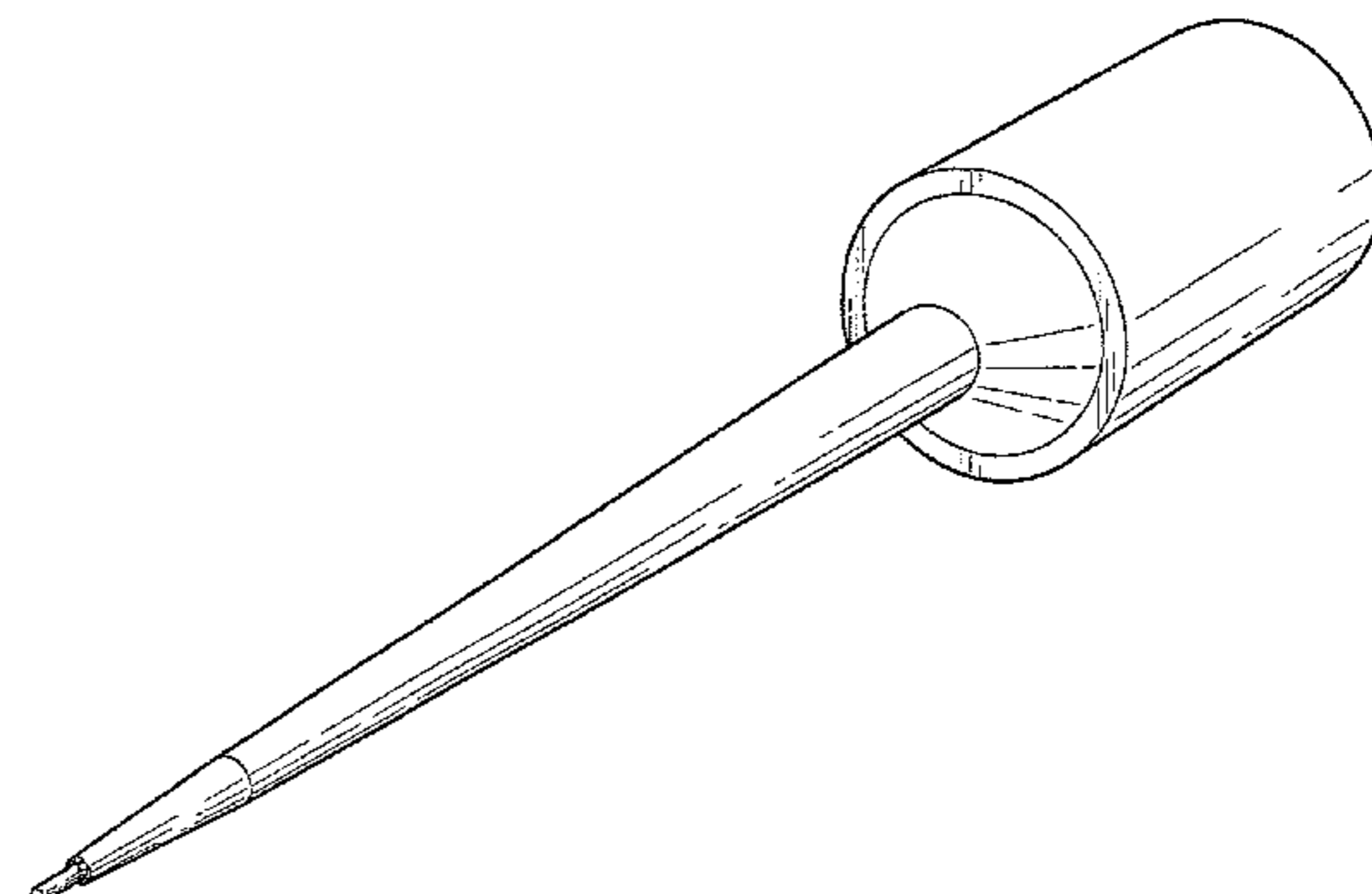

second embodiment showing an alternate condition of the second embodiment as in FIG. 20 of my new design.

1 Claim, 22 Drawing Sheets

(30) **Foreign Application Priority Data**

May 28, 2015 (JP) 2015-011787
 May 28, 2015 (JP) 2015-011788

(58) **Field of Classification Search**

CPC B01F 13/0025; B01J 2219/00292; B01J 2220/64; B01L 3/14; B01L 3/021-3/0237; B01L 3/508-3/50825; B01L 3/52-3/523; G01F 11/02
 See application file for complete search history.

(56) **References Cited**

U.S. PATENT DOCUMENTS

D384,418 S * 9/1997 Torti D24/222
 D401,698 S * 11/1998 Daniels D24/222

D441,458 S * 5/2001 Petrek D24/222
 D468,439 S * 1/2003 On D24/222
 D468,830 S * 1/2003 On D24/222
 D468,831 S * 1/2003 On D24/222
 D569,989 S * 5/2008 Tajima D24/222
 D601,712 S * 10/2009 Tajima D24/222
 D630,321 S * 1/2011 Hamilton, Jr. D24/133
 8,518,347 B2 * 8/2013 Tajima B01D 15/22
 422/501
 D709,623 S * 7/2014 Lohn D24/222
 D733,909 S * 7/2015 Lohn D24/222
 D733,910 S * 7/2015 Lohn D24/222
 D740,436 S * 10/2015 Lohn D24/222
 D740,437 S * 10/2015 Lohn D24/222
 9,421,538 B1 * 8/2016 Sung B01L 3/021
 D787,698 S * 5/2017 Staton D24/222
 D788,314 S * 5/2017 Ando D24/222
 10,005,594 B2 * 6/2018 Tajima B01L 3/0275
 2008/0078258 A1 * 4/2008 Price B01L 3/0279
 73/864.01
 2014/0308655 A1 * 10/2014 Mogas A01N 1/0268
 435/2
 2017/0001190 A1 * 1/2017 Ito B01L 3/0275

* cited by examiner

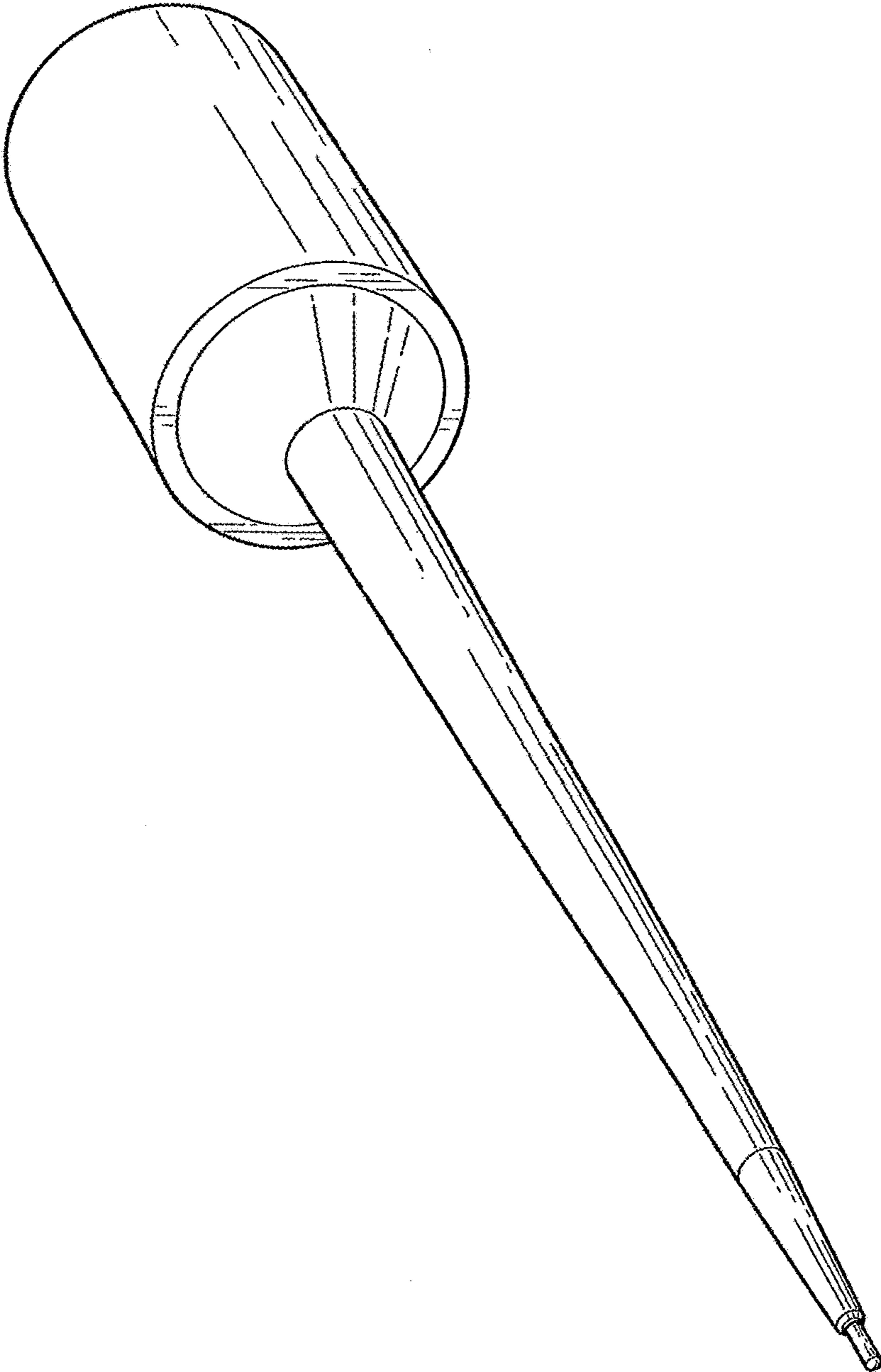

FIG. 1

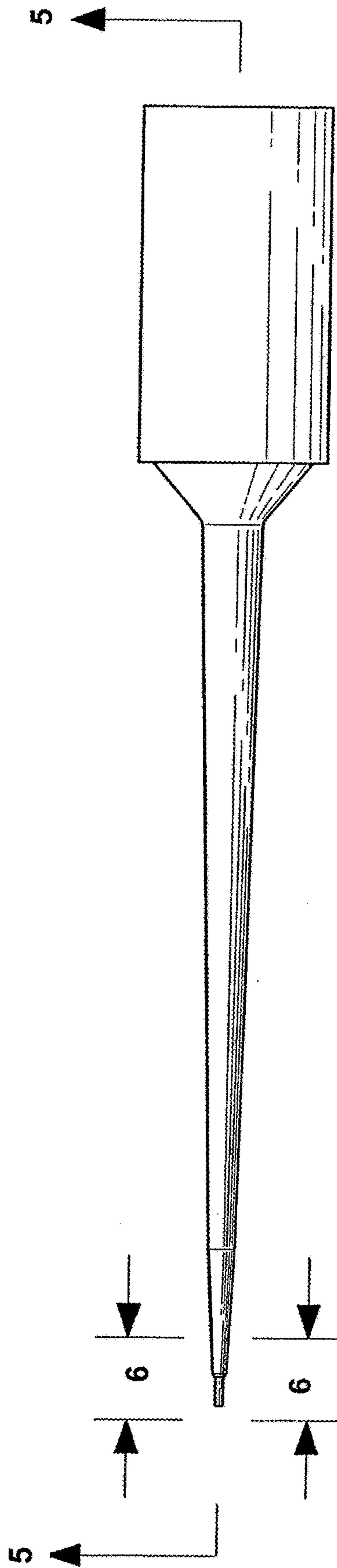

FIG. 2

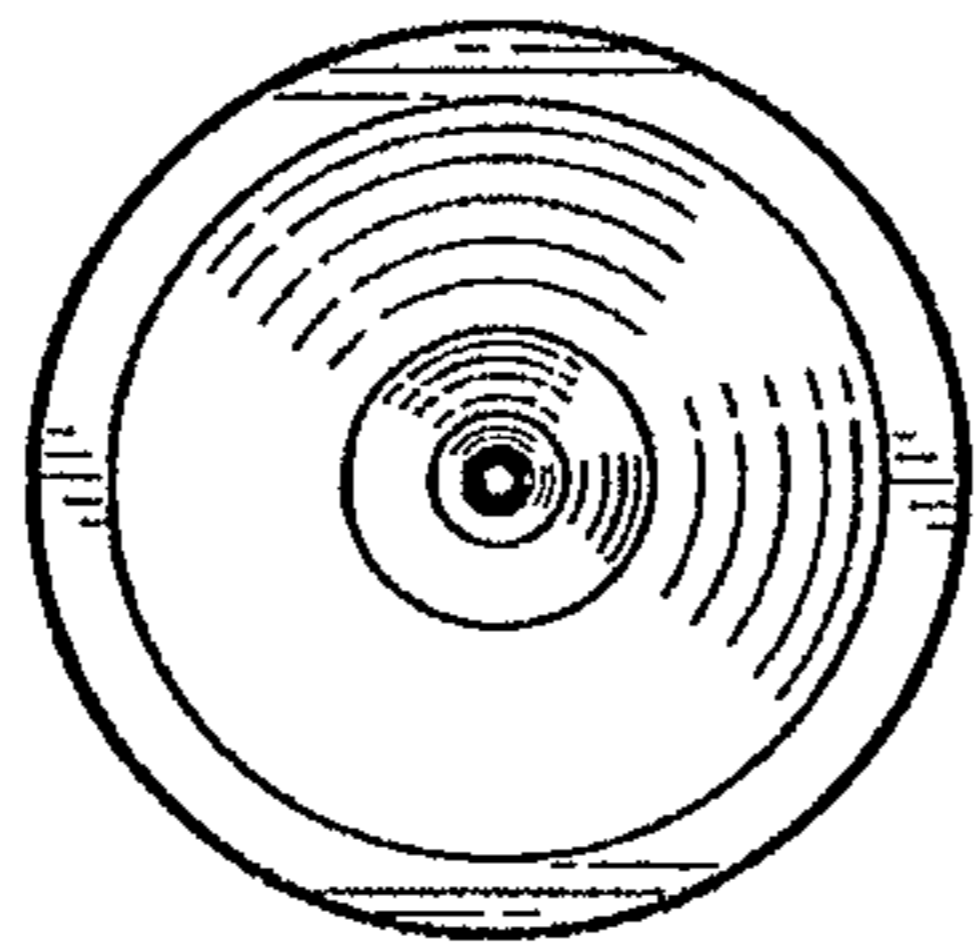

FIG. 3

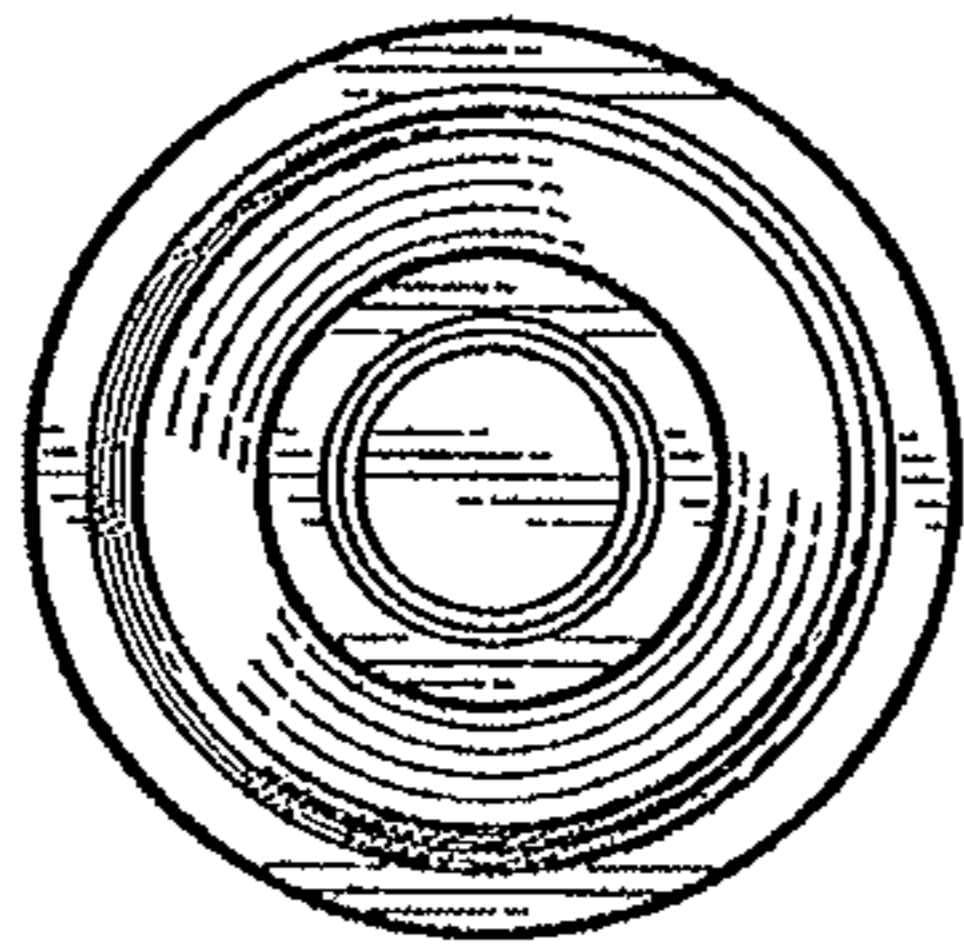

FIG. 4

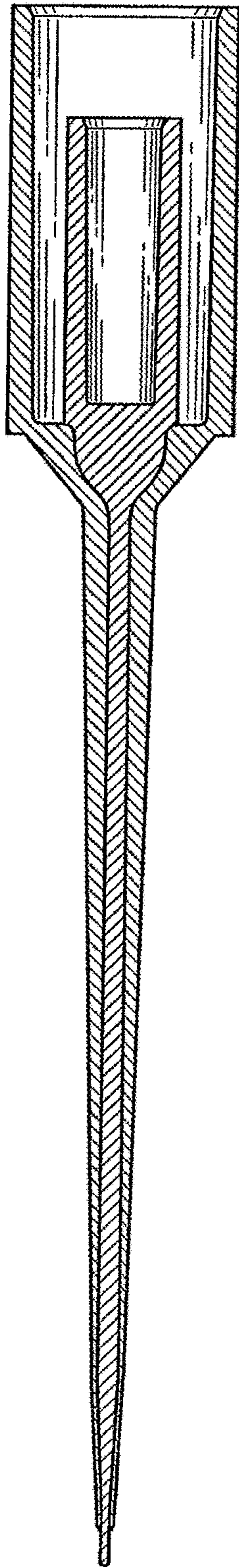

FIG. 5

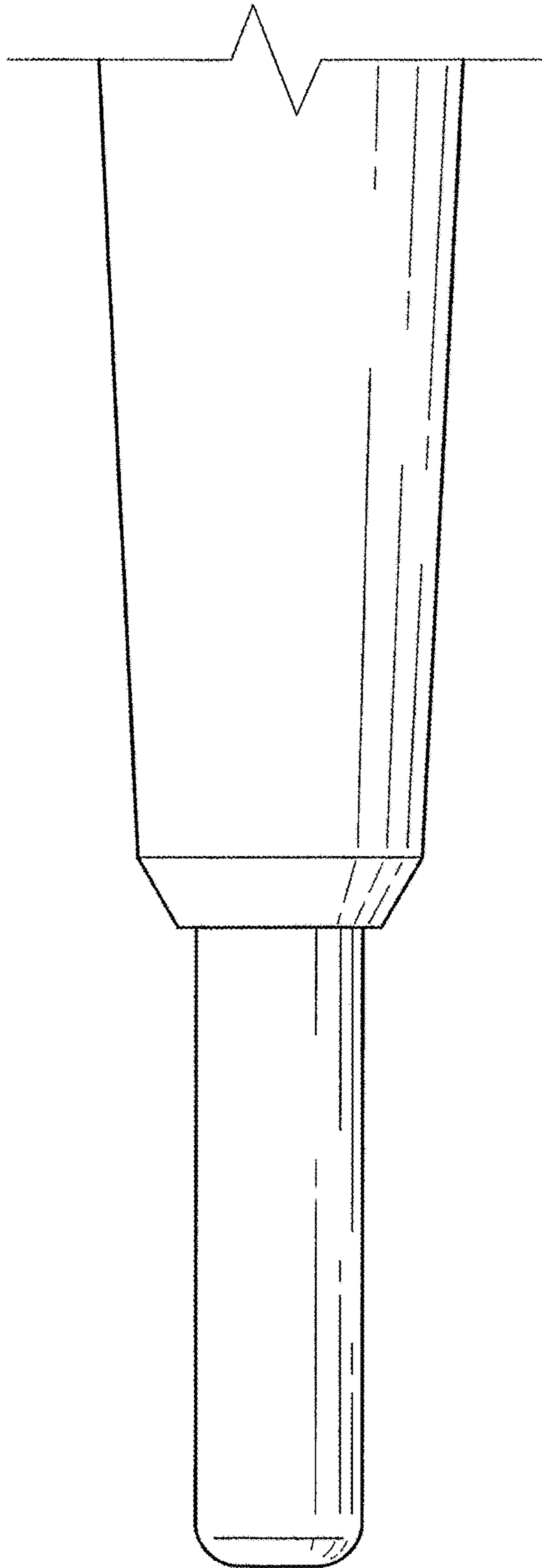

FIG. 6

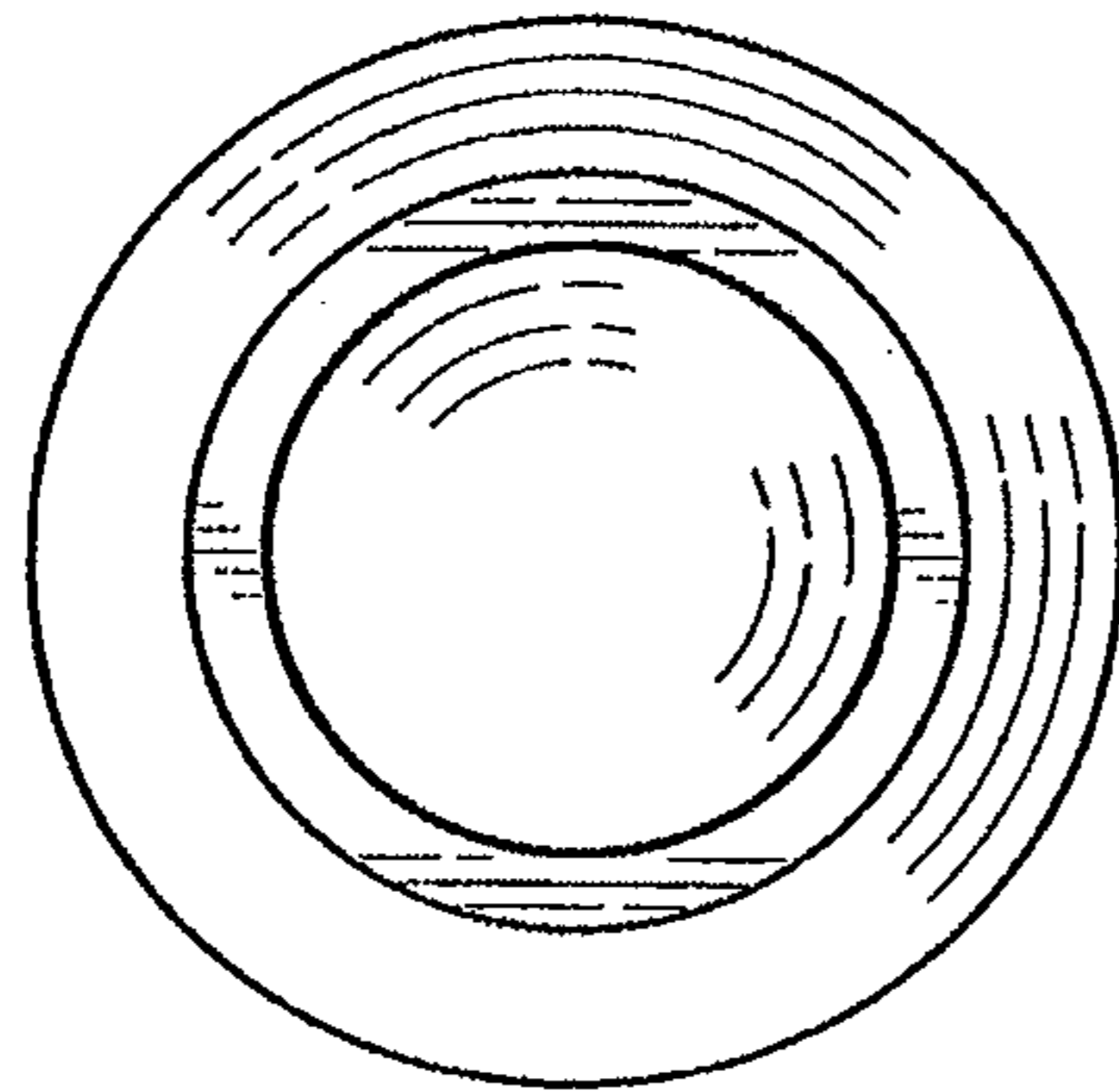

FIG. 7

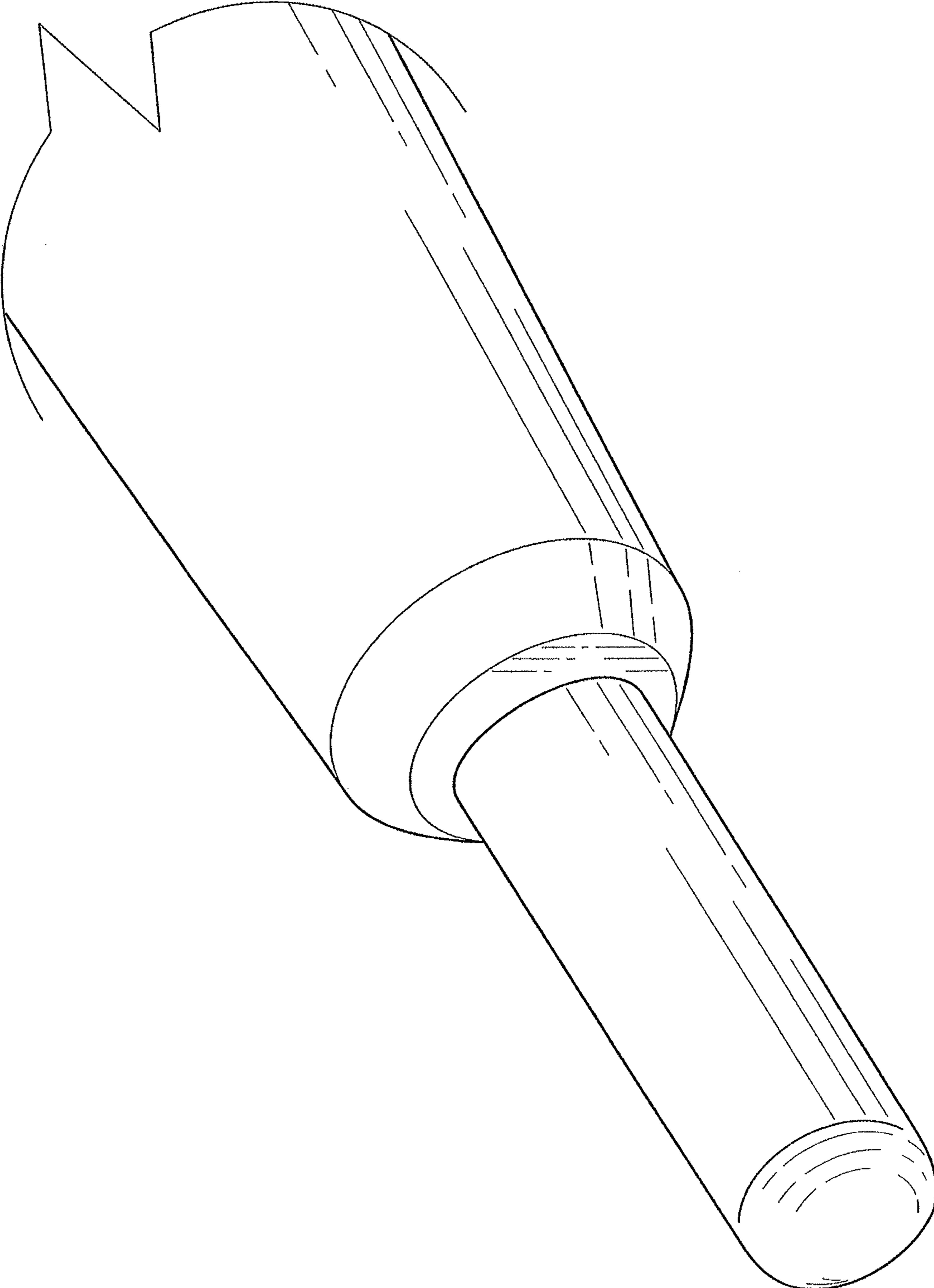

FIG. 8

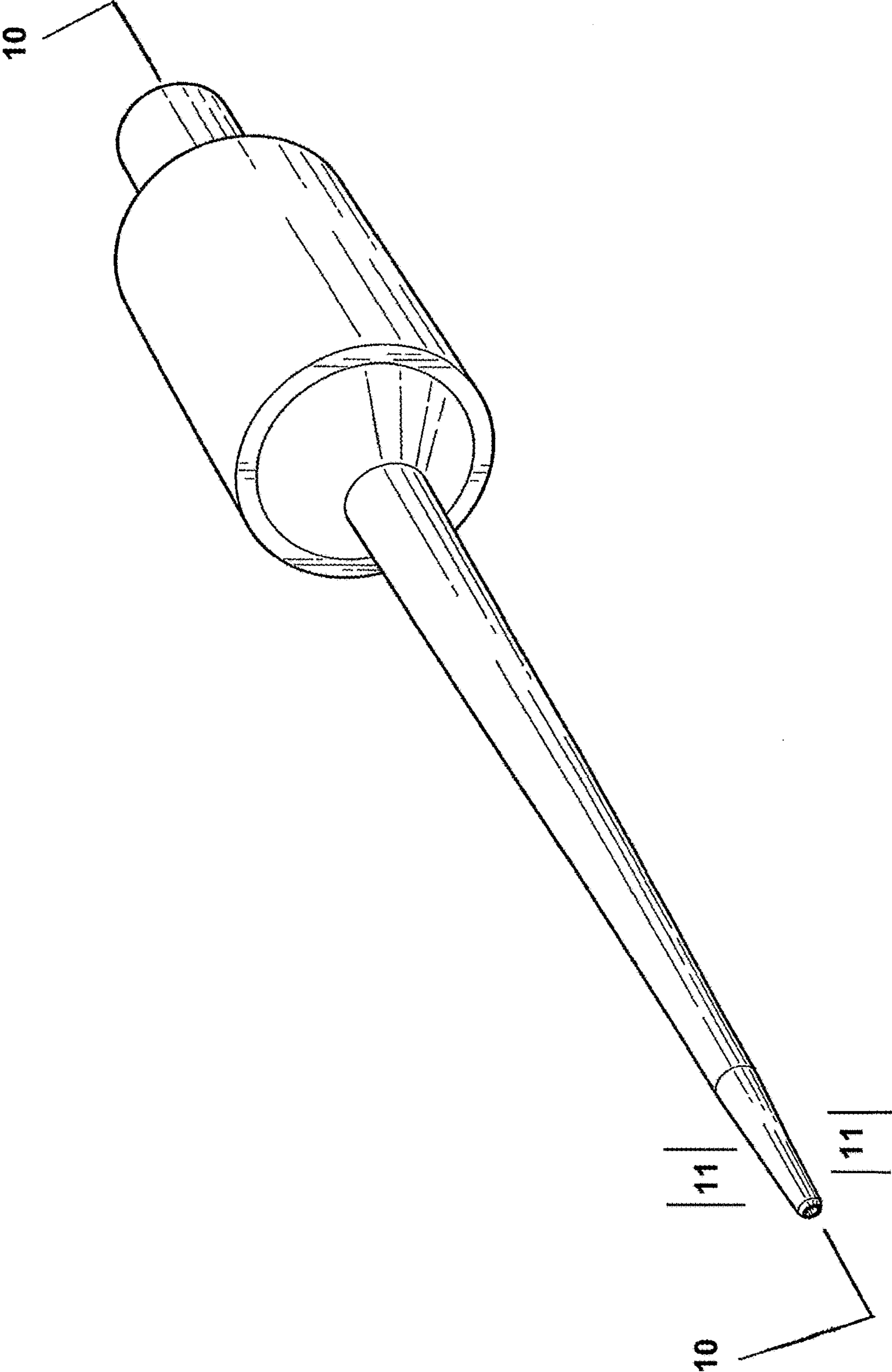

FIG. 9

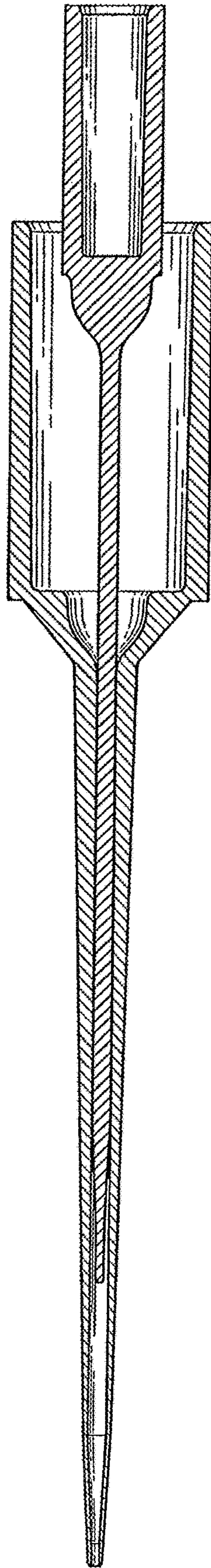

FIG. 10

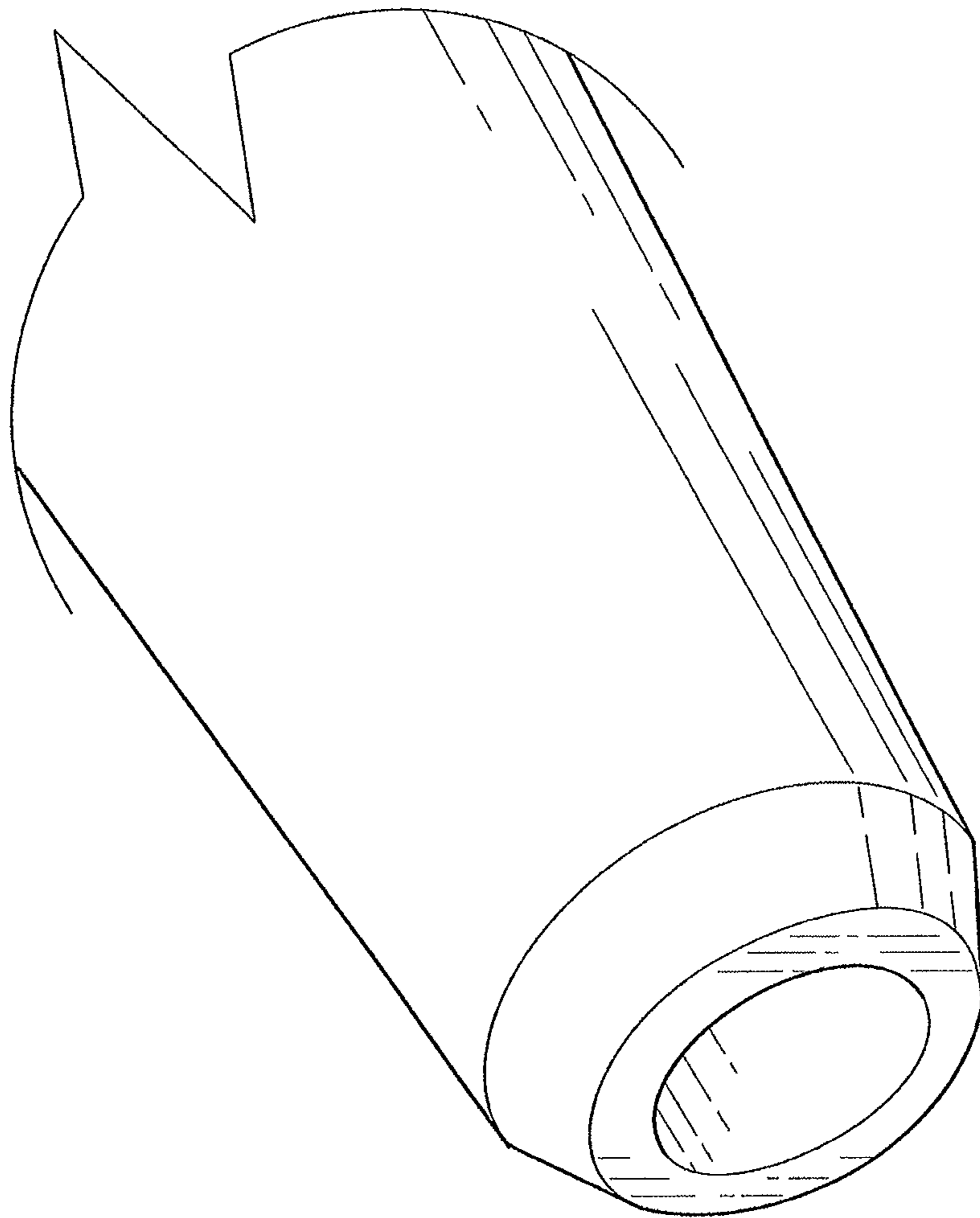

Fig.11

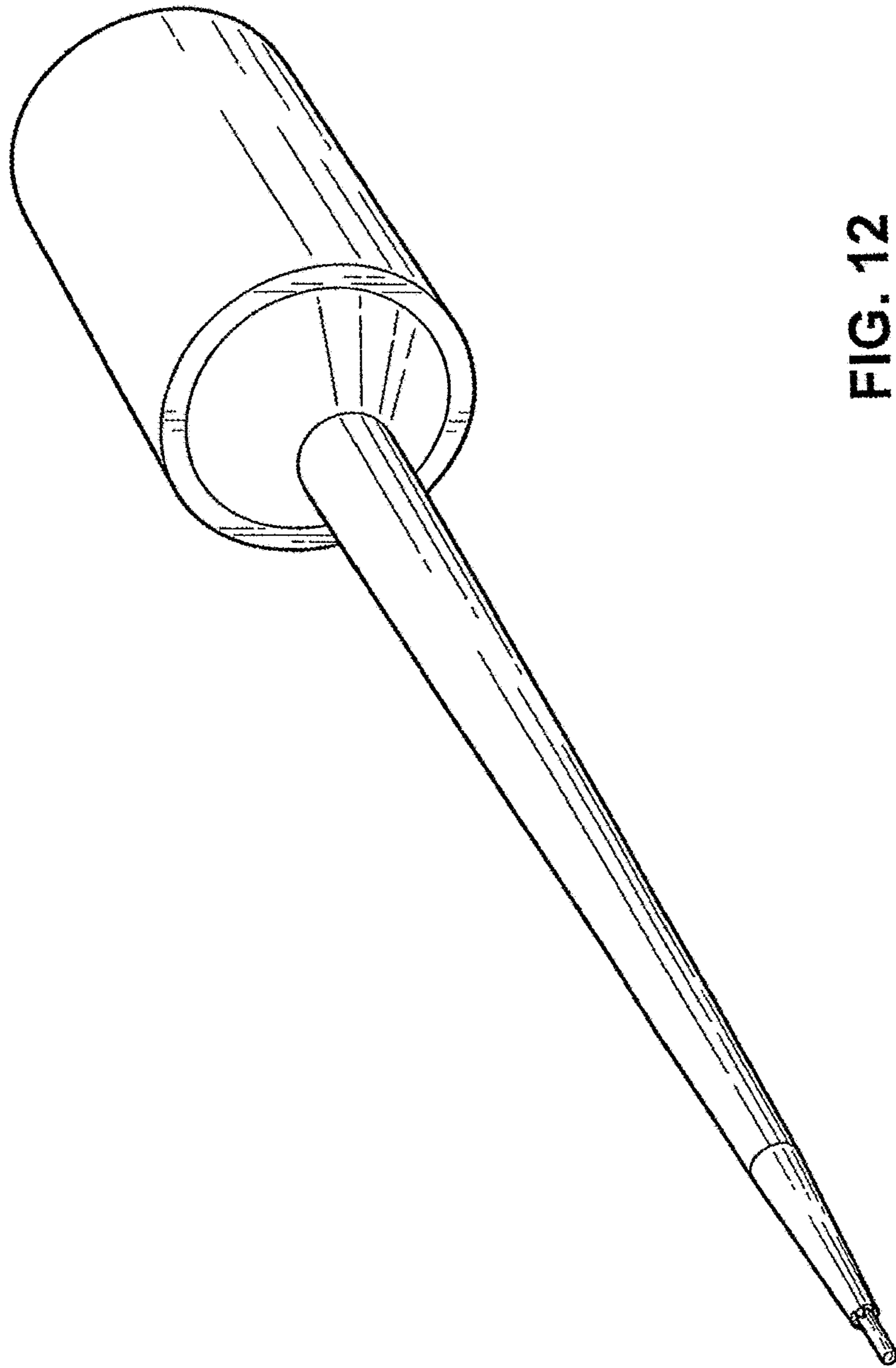

FIG. 12

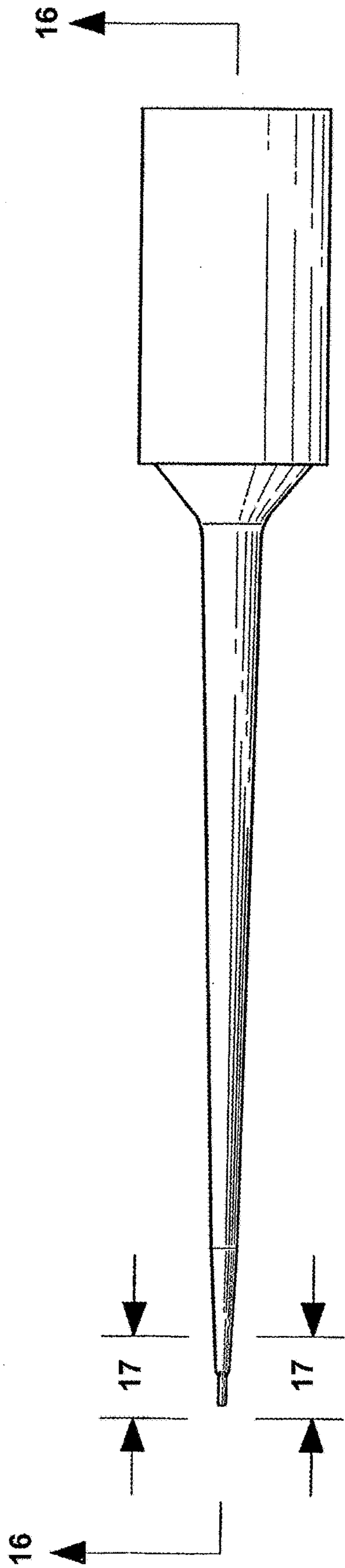

FIG. 13

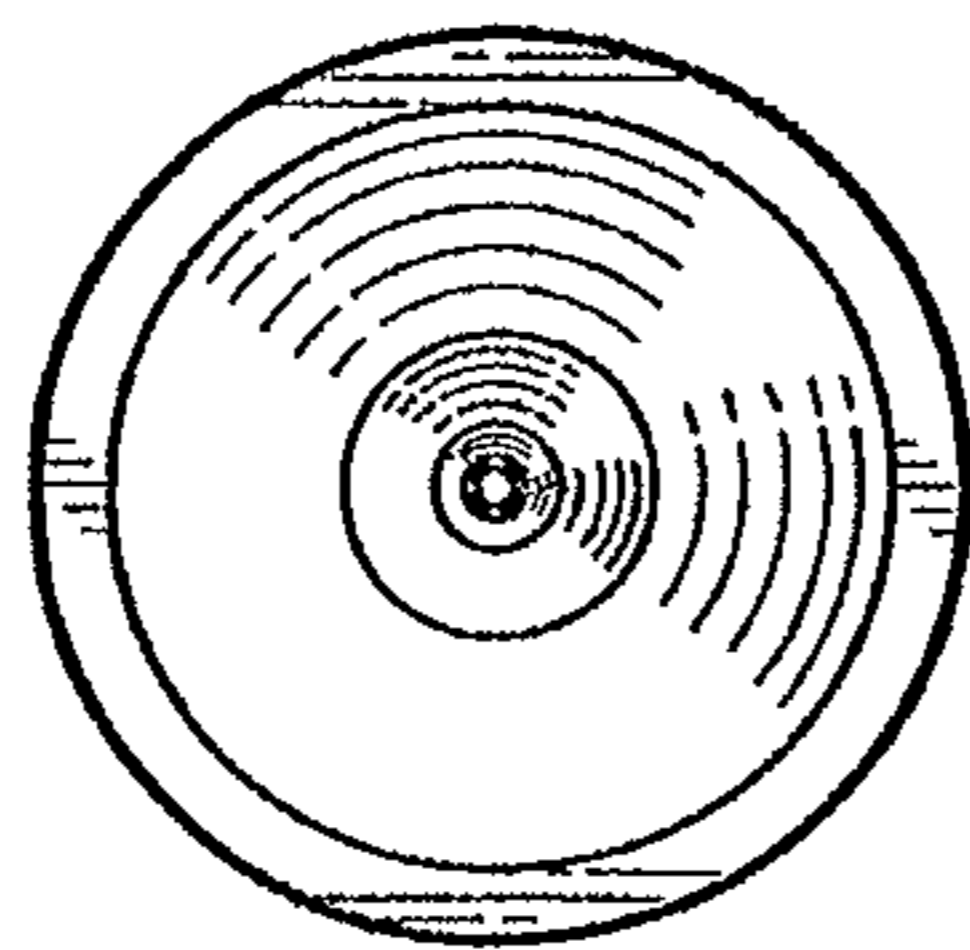

FIG. 14

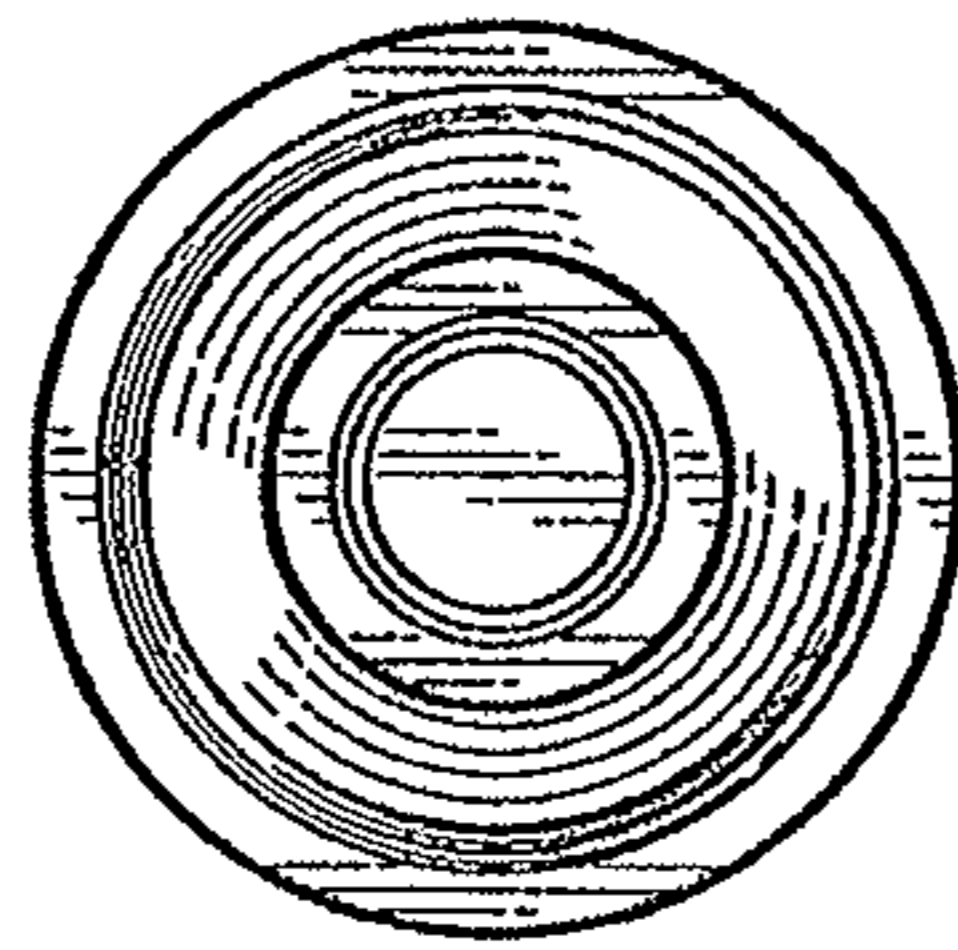

FIG. 15

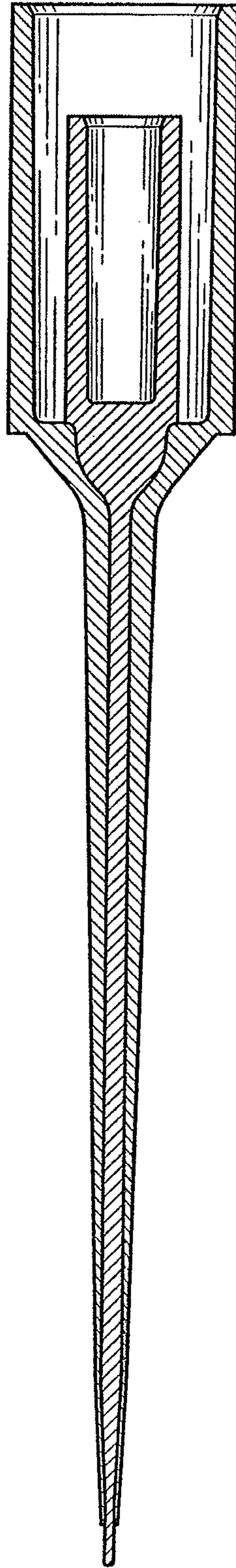

FIG. 16

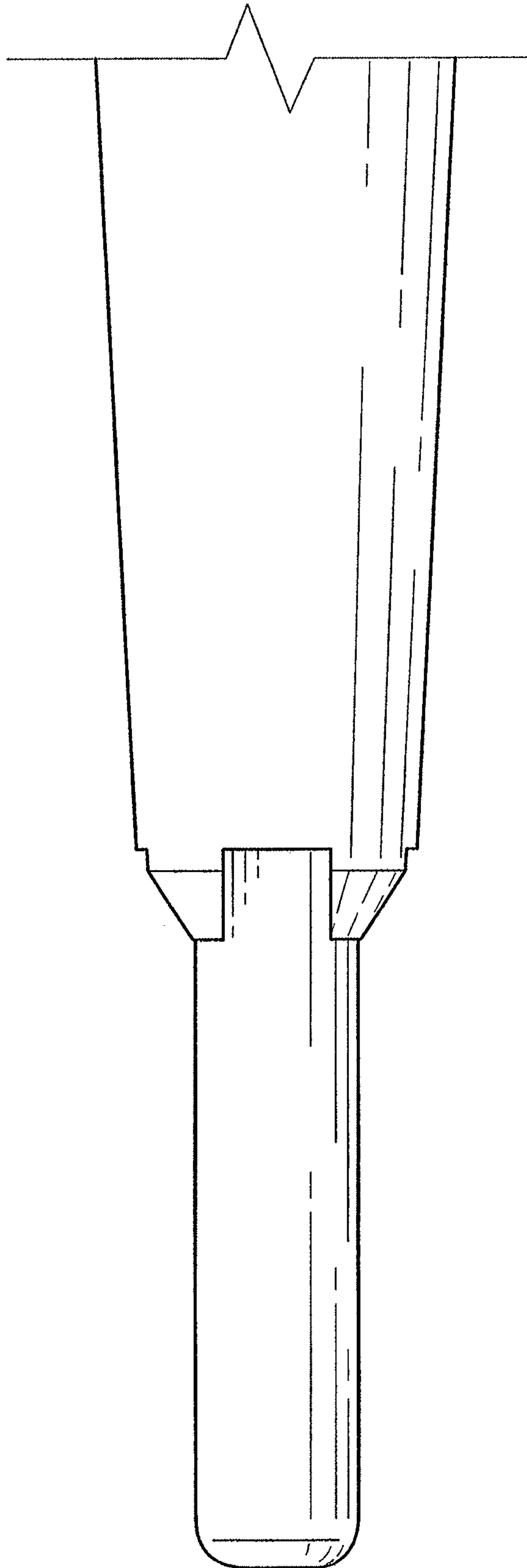

FIG. 17

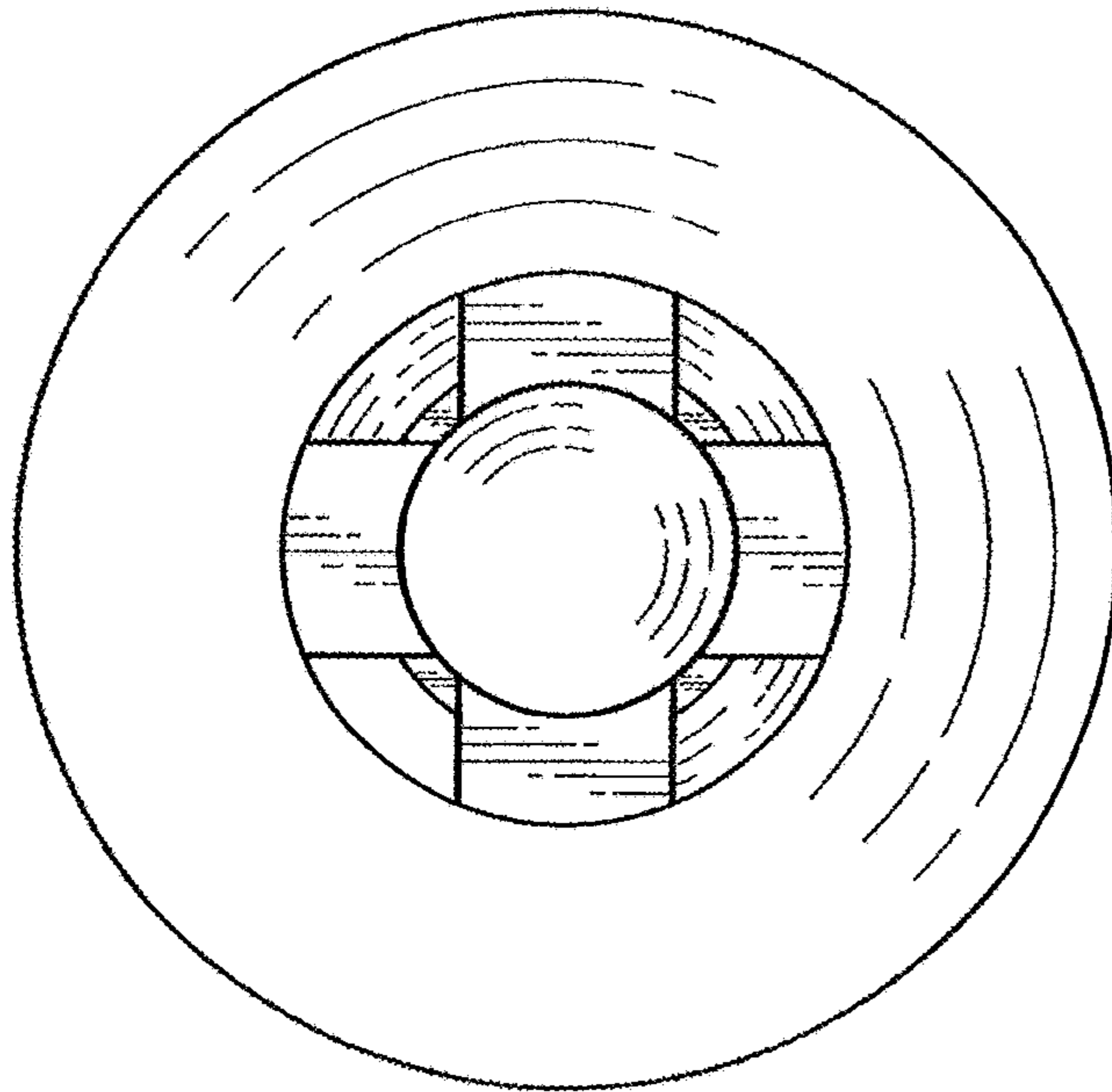

FIG. 18

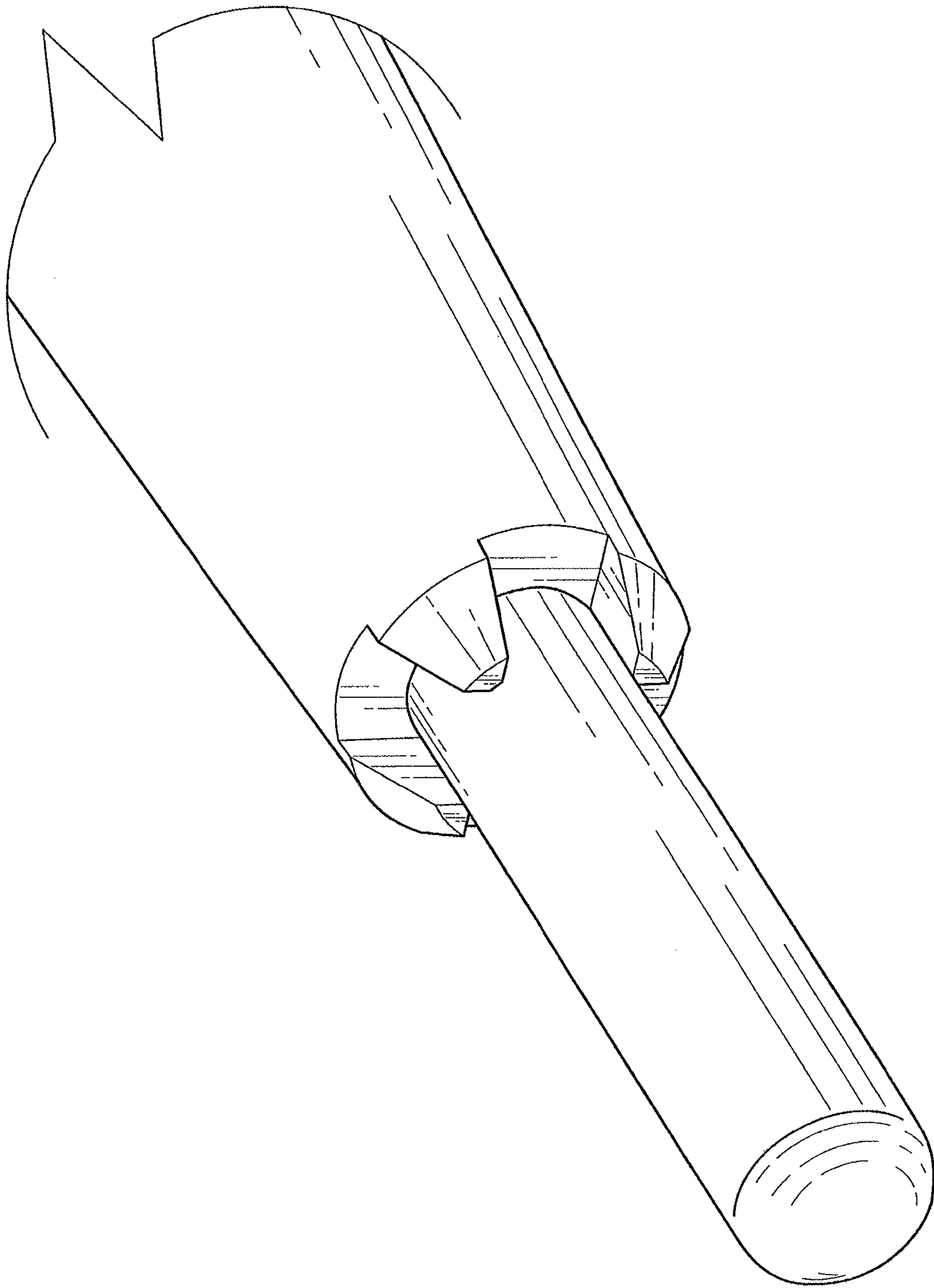

FIG. 19

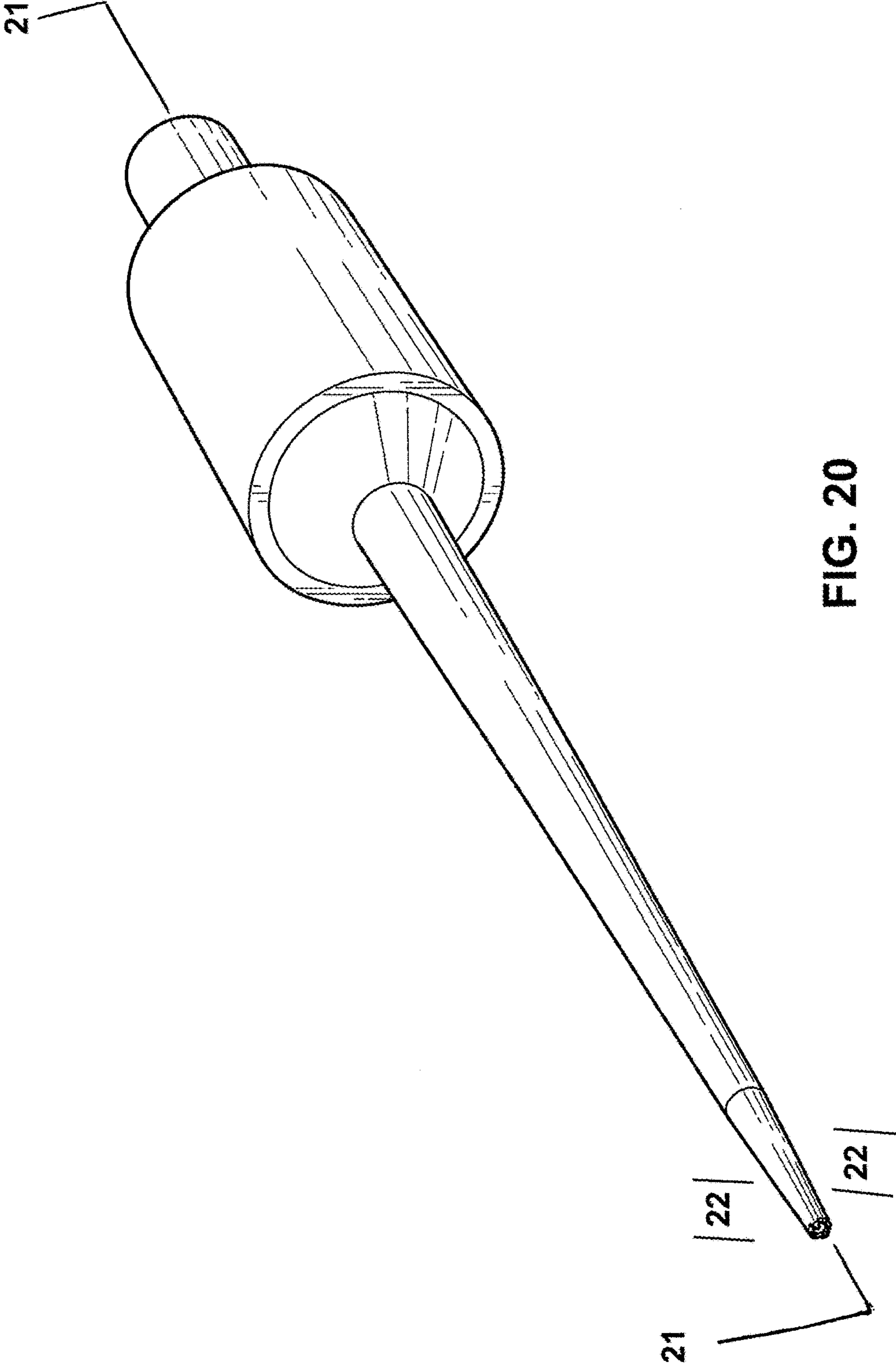

FIG. 20

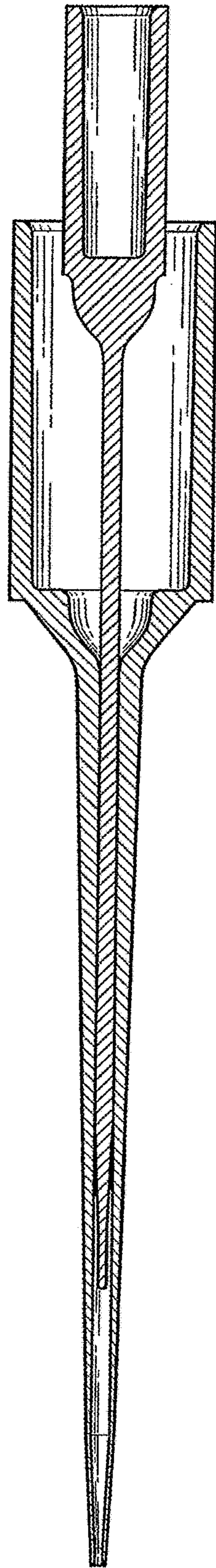

FIG. 21

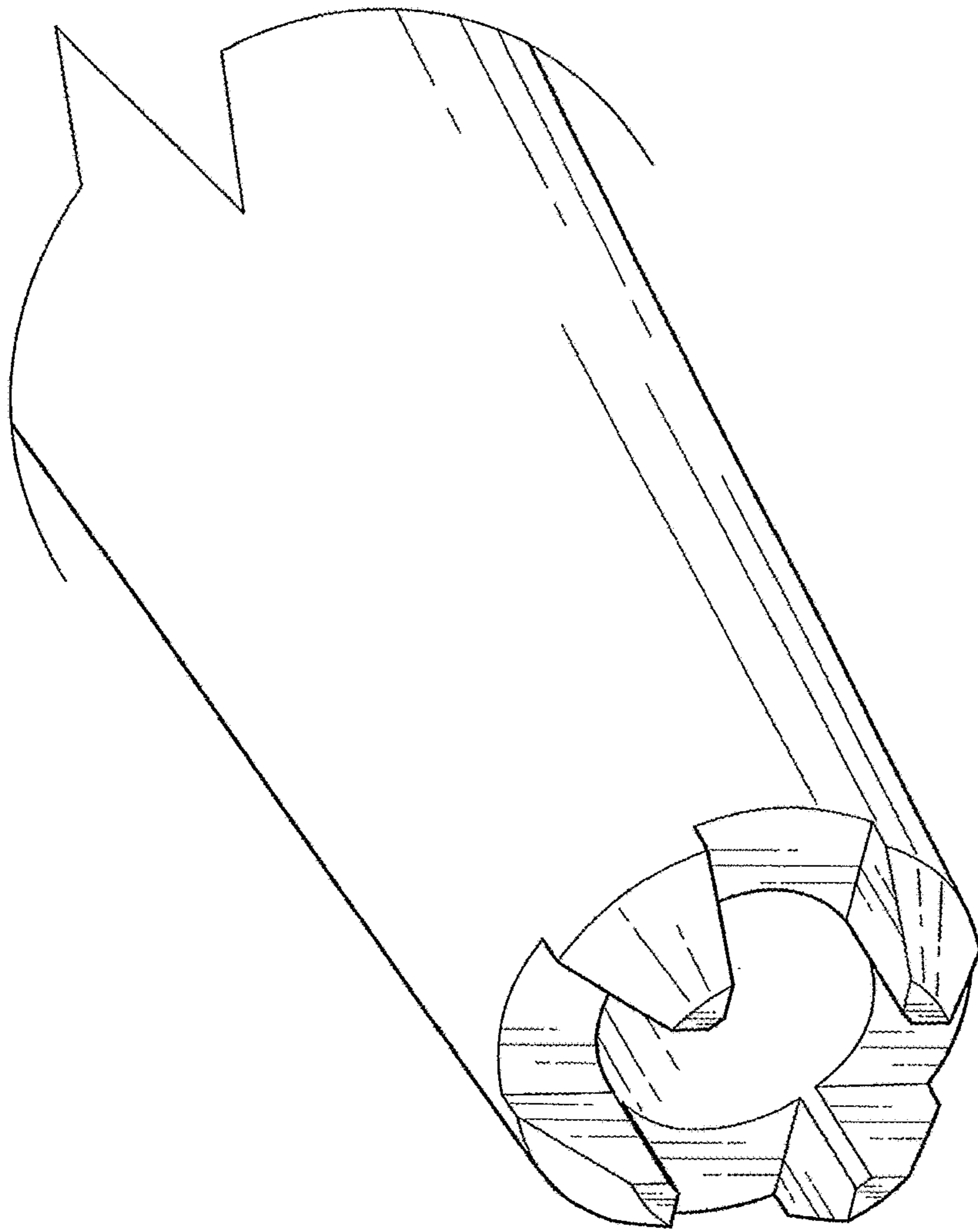

Fig.22