



US00D846142S

(12) **United States Design Patent** (10) **Patent No.:** **US D846,142 S**
Yellen et al. (45) **Date of Patent:** **** Apr. 16, 2019**

(54) **HANDHELD UV DISINFECTANT UNIT**

(71) Applicant: **Healthy Signoff, LLC**, Scottsdale, AZ (US)

(72) Inventors: **Iris Yellen**, Bloomfield Hills, MI (US);
Shelley Katz, Scottsdale, AZ (US);
Mario Alexander Esquer, Scottsdale, AZ (US)

(73) Assignee: **Healthy Signoff, LLC**, Scottsdale, AZ (US)

(**) Term: **15 Years**

(21) Appl. No.: **29/630,297**

(22) Filed: **Dec. 20, 2017**

(51) **LOC (11) Cl.** **24-01**

(52) **U.S. Cl.**
USPC **D24/217**

(58) **Field of Classification Search**
USPC D24/216, 217, 218, 219, 224-232;
D23/366; D28/44, 73; D32/1, 25;
D10/78
CPC A61L 2/26; A61L 2/24; A61L 2/17; A61L
2/18; A61L 2/025; A61L 2202/122; A61L
2202/10; A61L 2202/11; A61L 2202/14;
A61L 2202/23; A61L 2202/24; A61L
2202/182

See application file for complete search history.

(56) **References Cited**

U.S. PATENT DOCUMENTS

| | | | | |
|-------------------|--------|--------|-------|------------------------|
| D485,364 S * | 1/2004 | Lee | | D24/217 |
| D502,266 S * | 2/2005 | Shin | | D24/217 |
| D542,930 S * | 5/2007 | Shin | | D24/217 |
| D652,529 S * | 1/2012 | Eum | | D24/217 |
| D752,997 S * | 4/2016 | Miller | | D10/52 |
| 2010/0102252 A1 * | 4/2010 | Harmon | | A61L 2/10 250/492.1 |
| 2018/0117191 A1 * | 5/2018 | Shell | | A61L 2/10 |

* cited by examiner

Primary Examiner — Anhdao Doan
(74) *Attorney, Agent, or Firm* — Brooks Kushman P.C.

(57) **CLAIM**

The ornamental design for a handheld UV disinfectant unit, as shown and described.

DESCRIPTION

FIG. 1 is a front perspective view of a handheld ultraviolet (UV) disinfectant unit, showing my new design; FIG. 2 is top plan view of FIG. 1; FIG. 3 is a bottom plan view of FIG. 1; FIG. 4 is a right side elevational view of FIG. 1; FIG. 5 is a left side elevational view of FIG. 1; FIG. 6 is a rear elevational view of FIG. 1; and, FIG. 7 is a front elevational view of FIG. 1.

1 Claim, 4 Drawing Sheets

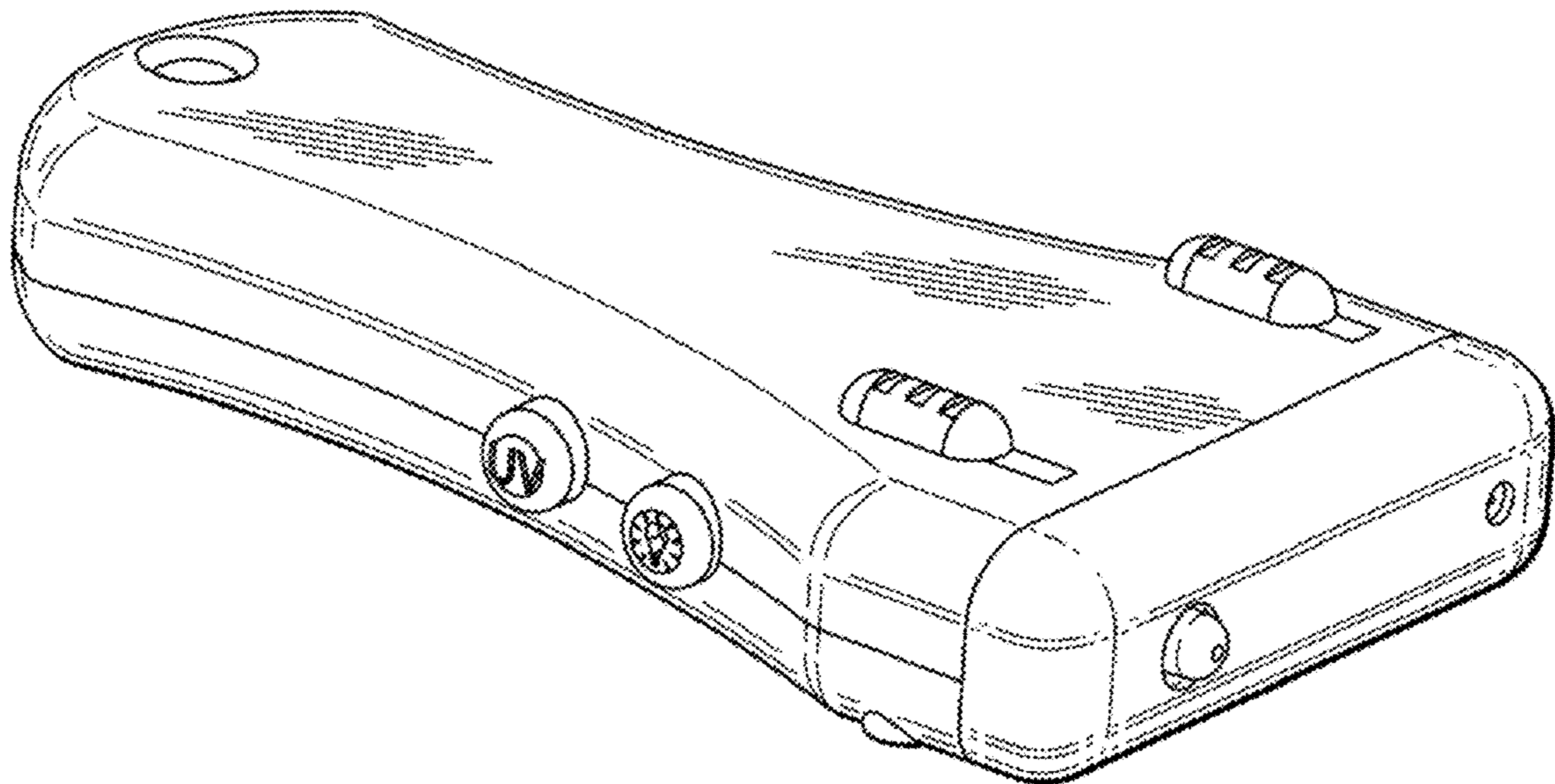

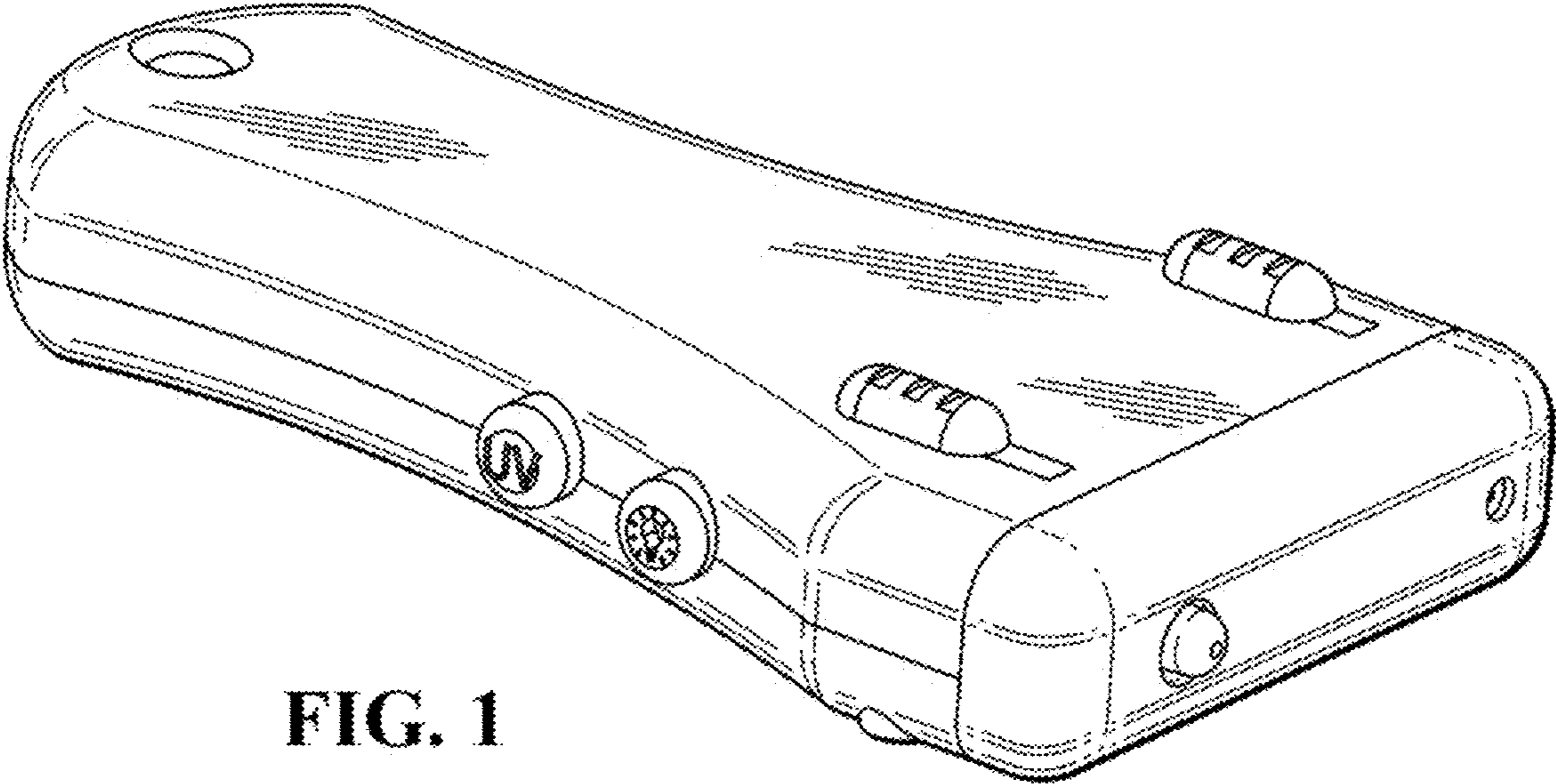

FIG. 1

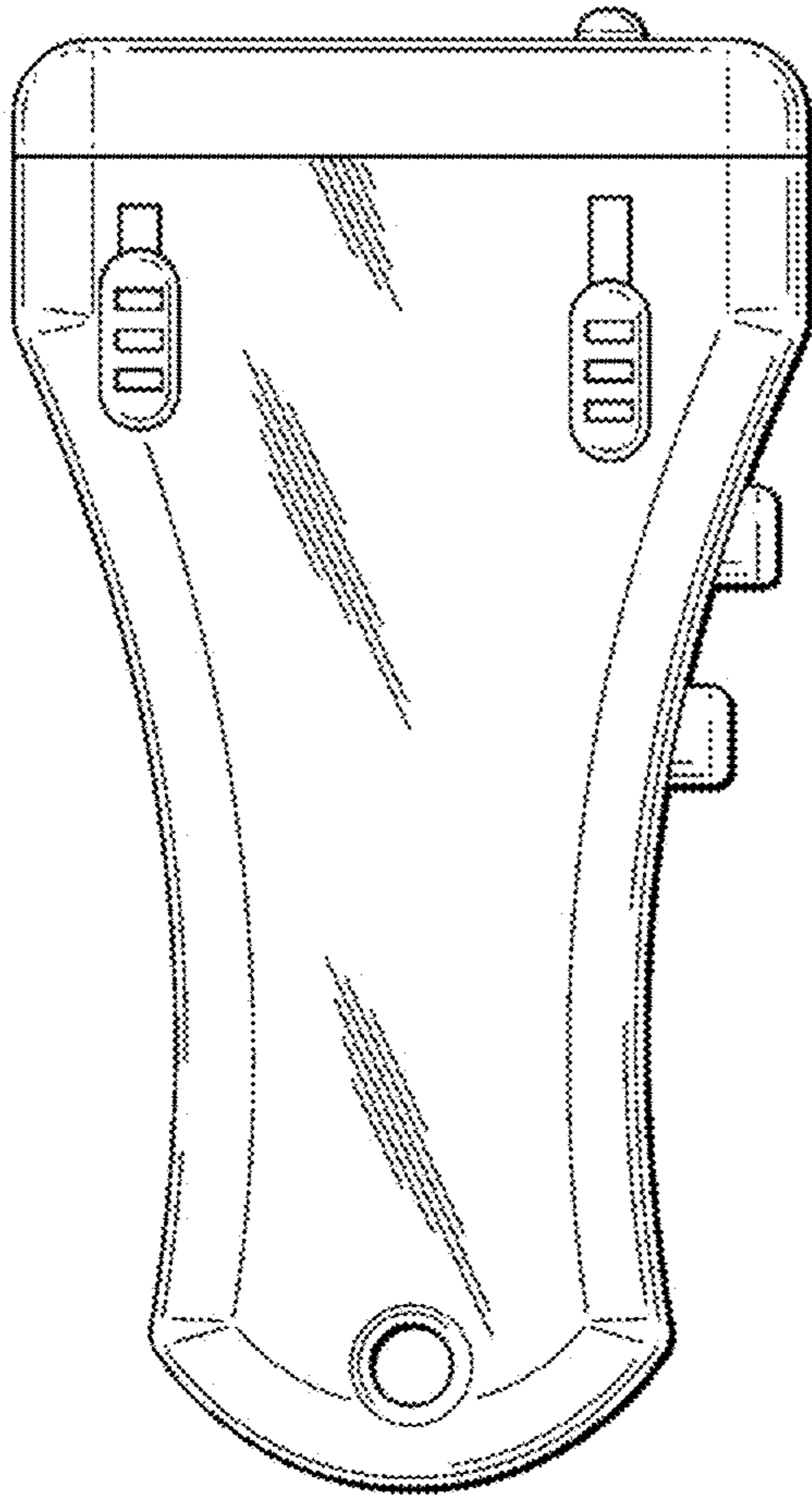

FIG. 2

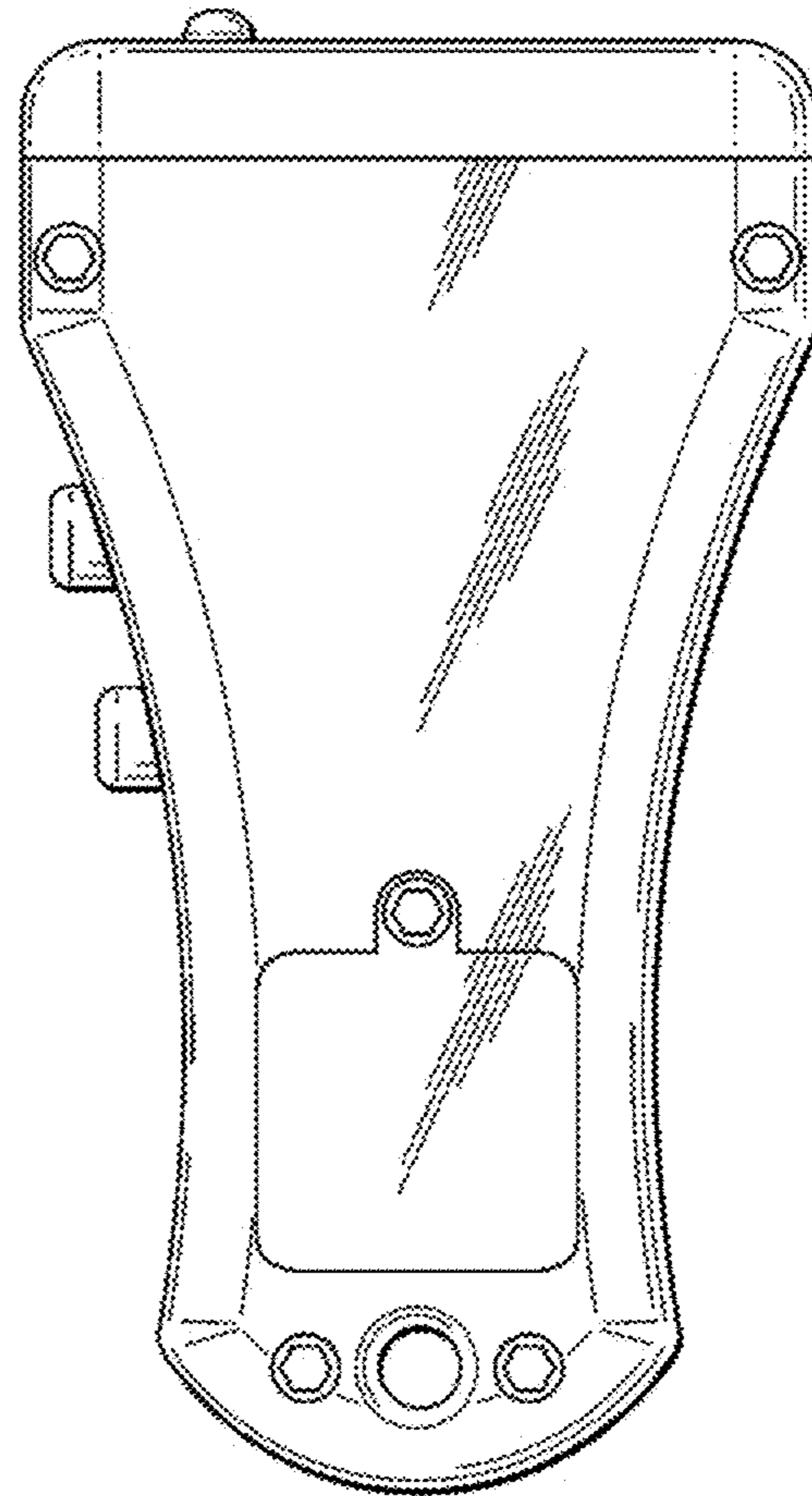

FIG. 3

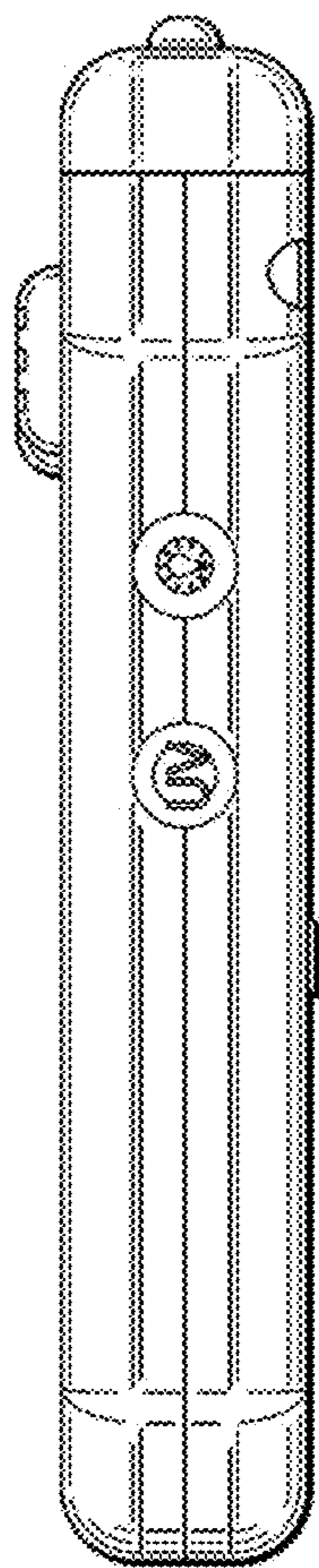

FIG. 4

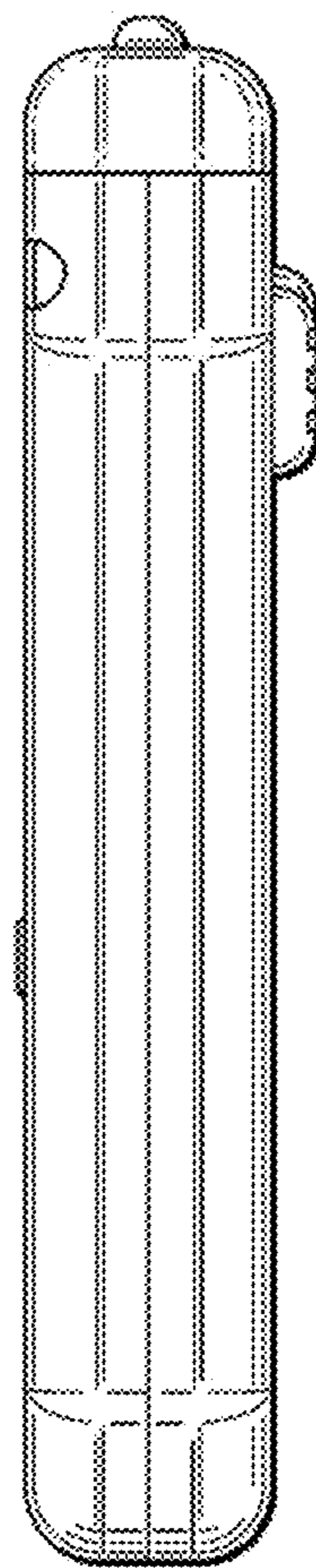

FIG. 5

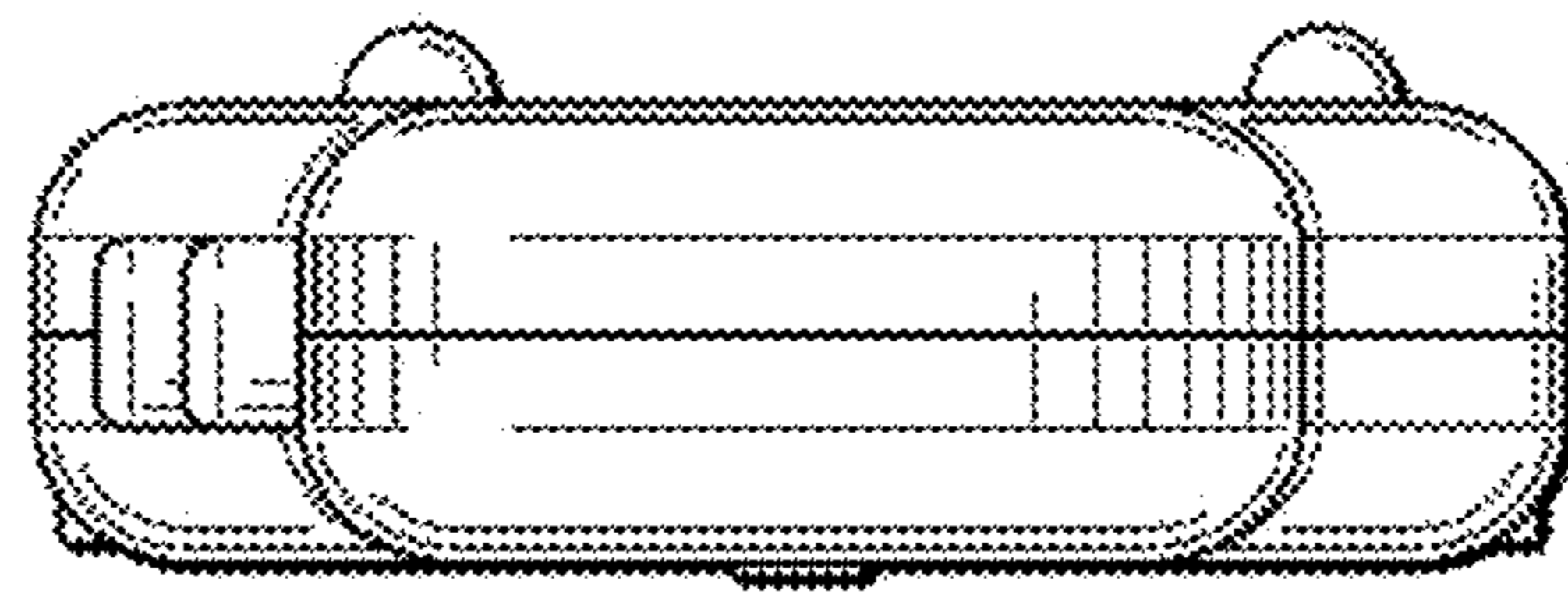

FIG. 6

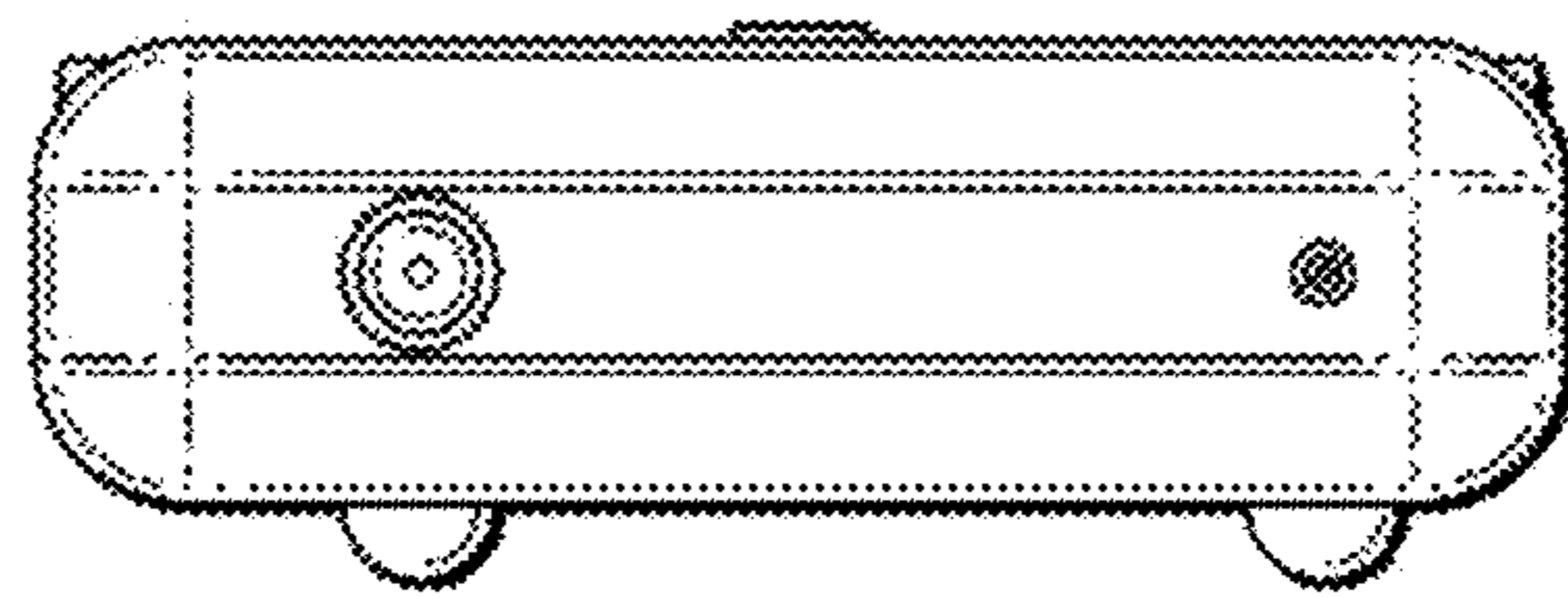

FIG. 7