



US00D845926S

(12) **United States Design Patent**  
**Aoyagi et al.**

(10) **Patent No.:** **US D845,926 S**  
(45) **Date of Patent:** **\*\* Apr. 16, 2019**

(54) **EARPHONES**

- (71) Applicant: **Apple Inc.**, Cupertino, CA (US)
- (72) Inventors: **Shota Aoyagi**, San Francisco, CA (US);  
**Robert Brunner**, San Francisco, CA (US);  
**Monica Fernandez**, Los Angeles, CA (US);  
**Christopher Kuh**, San Francisco, CA (US);  
**Christopher J. Stringer**, Woodside, CA (US)
- (73) Assignee: **Apple Inc.**, Cupertino, CA (US)
- (\*\*) Term: **15 Years**

- (21) Appl. No.: **29/609,517**
- (22) Filed: **Jun. 30, 2017**
- (51) **LOC (11) Cl.** ..... **14-01**
- (52) **U.S. Cl.**  
USPC ..... **D14/205**
- (58) **Field of Classification Search**  
USPC ..... D14/205, 223, 218; 181/129, 130, 135;  
379/430, 431; 381/380, 381, 370, 374;  
455/90, 3, 575.1, 569.1; D13/154, 168  
(Continued)

(56) **References Cited**

**U.S. PATENT DOCUMENTS**

- 2,120,469 A \* 6/1938 Kyle ..... H01R 4/52  
439/787
- 2,248,837 A 7/1941 Walters  
(Continued)

**FOREIGN PATENT DOCUMENTS**

- CN 206323524 U 8/2013
- CN 303159413 4/2015  
(Continued)

**OTHER PUBLICATIONS**

John Schettino, Nyrius NAE500 Noise Isolating In-Ear Earphones Review, Online Review, Feb. 23, 2012.  
(Continued)

*Primary Examiner* — Paula Allen Greene  
(74) *Attorney, Agent, or Firm* — Sterne, Kessler, Goldstein & Fox P.L.L.C.

(57) **CLAIM**

The ornamental design for earphones, as shown and described.

**DESCRIPTION**

FIG. 1 is a top front perspective view of earphones showing the claimed design;  
 FIG. 2 is a front view thereof;  
 FIG. 3 is a rear view thereof;  
 FIG. 4 is a right side view thereof;  
 FIG. 5 is a left side view thereof;  
 FIG. 6 is a top view thereof;  
 FIG. 7 is a bottom view thereof;  
 FIG. 8 is a top front perspective view of earphones showing the claimed design;  
 FIG. 9 is a front view thereof;  
 FIG. 10 is a rear view thereof;  
 FIG. 11 is a right side view thereof;  
 FIG. 12 is a left side view thereof;  
 FIG. 13 is a top view thereof; and,  
 FIG. 14 is a bottom view thereof.

The broken lines in the figures show portions of the earphones that form no part of the claimed design.  
 The closely-adjacent wavy broken lines in FIGS. 8-14 show symbolic breaks in the length of the earphone cable, and form no part of the claimed design. The appearance of any portion or length of the cable between the break lines forms no part of the claimed design.  
 The embodiment of FIGS. 1-7 differs from the embodiment of FIGS. 8-14 only in the cable length, which is shown in solid lines in FIGS. 1-7.

**1 Claim, 6 Drawing Sheets**

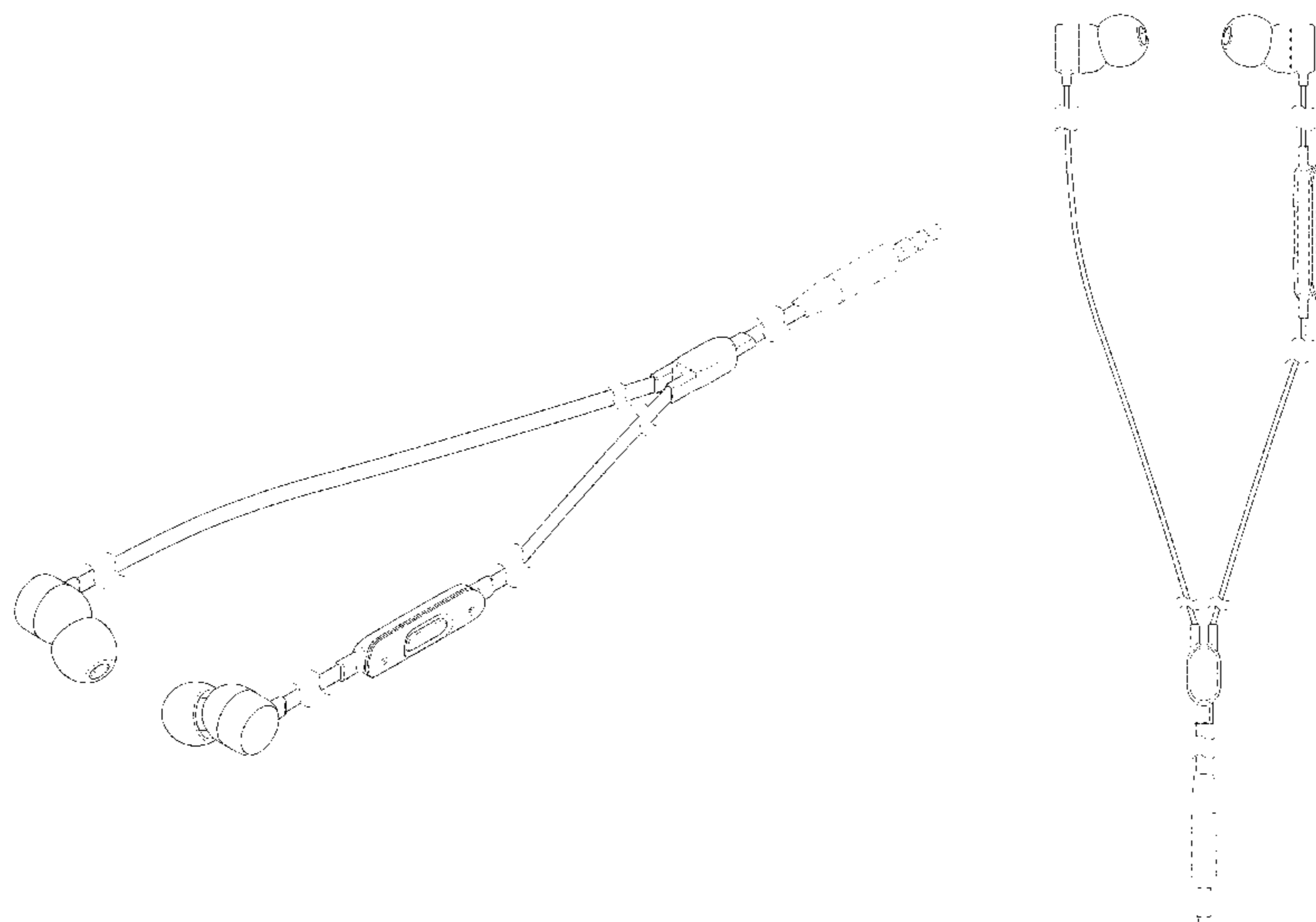

(58) **Field of Classification Search**  
 CPC ..... H04R 1/1033; H04R 1/10; H04R 25/00;  
 H04R 1/1016; H04R 1/1066; H04R  
 5/0335; H04R 5/033  
 See application file for complete search history.

(56) **References Cited**

U.S. PATENT DOCUMENTS

2,430,229 A 11/1947 Kelsey  
 2,501,107 A 3/1950 Volkmann  
 2,545,731 A 3/1951 French  
 D168,240 S 11/1952 Rodrieguez  
 2,739,660 A 3/1956 French  
 3,049,582 A \* 8/1962 Shinn ..... H01R 4/70  
 174/92  
 3,195,392 A \* 7/1965 Allen ..... G10G 7/02  
 181/130  
 3,301,253 A 1/1967 Glorig  
 D241,881 S 10/1976 Peterson  
 4,457,396 A \* 7/1984 James ..... H04R 1/345  
 181/129  
 D278,234 S \* 4/1985 Saito ..... D14/205  
 D309,306 S 7/1990 Weiser et al.  
 D337,587 S 7/1993 Nakayama  
 D350,354 S 9/1994 Nakamura  
 5,625,171 A 4/1997 Marshall  
 5,659,156 A 8/1997 Mauney et al.  
 5,749,373 A 5/1998 Dix  
 5,792,998 A 8/1998 Gardner, Jr. et al.  
 5,829,062 A 11/1998 Magidson  
 6,010,216 A 1/2000 Jesiek  
 6,233,345 B1 5/2001 Urwyler  
 D458,245 S 6/2002 Masuda  
 D466,100 S 11/2002 Obata et al.  
 D473,217 S \* 4/2003 Rivera ..... D14/223  
 6,603,863 B1 8/2003 Nagayoshi  
 D482,348 S 11/2003 Villaverde et al.  
 6,741,719 B1 5/2004 Orten  
 6,799,018 B1 9/2004 Lam  
 D504,177 S 4/2005 Erfan  
 7,010,139 B1 3/2006 Smeehuyzen  
 D519,108 S \* 4/2006 Yang ..... D14/223  
 D535,642 S 1/2007 Garcia et al.  
 D546,321 S 7/2007 Kim  
 D550,202 S 9/2007 Meier et al.  
 D550,657 S 9/2007 Gan et al.  
 D554,109 S 10/2007 Ledbetter et al.  
 D575,268 S 8/2008 Christopher et al.  
 D576,149 S 9/2008 Malik et al.  
 D576,154 S 9/2008 Ledbetter et al.  
 D578,507 S 10/2008 Ando  
 D579,005 S 10/2008 Wilhelmsen  
 D579,444 S 10/2008 Ewert et al.  
 D587,678 S 3/2009 Yuyama  
 D587,681 S \* 3/2009 Yanai ..... D14/205  
 D587,685 S 3/2009 Densho  
 D589,493 S 3/2009 Densho  
 D593,067 S 5/2009 Millora et al.  
 D594,441 S 6/2009 Lee et al.  
 D594,442 S 6/2009 Chon et al.  
 D596,617 S 7/2009 Devlas et al.  
 D597,071 S \* 7/2009 Andre ..... D14/206  
 D598,901 S 8/2009 Lee et al.  
 D599,778 S \* 9/2009 Ando ..... D14/205  
 D599,781 S 9/2009 Lee et al.  
 D600,675 S 9/2009 Lee et al.  
 D604,269 S 11/2009 Choe  
 D604,272 S 11/2009 Kitayama  
 D605,628 S \* 12/2009 Ando ..... D14/205  
 D606,971 S 12/2009 Christopher et al.  
 7,639,824 B2 \* 12/2009 Franzen ..... H04R 1/1016  
 381/151  
 D607,875 S \* 1/2010 Pedersen, II ..... H04R 1/1033  
 D14/206  
 D609,698 S 2/2010 Ng  
 D621,389 S 8/2010 Nagayama et al.

D622,707 S 8/2010 Chen et al.  
 D623,630 S 9/2010 Otori et al.  
 D625,292 S \* 10/2010 Andre ..... D14/217  
 D627,764 S 11/2010 Tsai et al.  
 D627,765 S 11/2010 Zheng  
 D629,793 S 12/2010 Göransson  
 D630,179 S 1/2011 Park et al.  
 D631,037 S 1/2011 Park et al.  
 D636,763 S 4/2011 Walter  
 7,920,902 B2 4/2011 Carroll  
 D637,585 S 5/2011 Nagayama et al.  
 D643,830 S 8/2011 Fish  
 D648,708 S 11/2011 Katsuraku et al.  
 D650,368 S 12/2011 Lee et al.  
 D653,234 S 1/2012 Lee  
 D656,489 S 3/2012 Kumagai et al.  
 D656,491 S 3/2012 Nomura  
 D656,492 S \* 3/2012 Huang ..... D14/205  
 8,144,915 B2 \* 3/2012 Hankey ..... H01H 9/0228  
 381/370  
 D663,714 S 7/2012 Kang et al.  
 D666,581 S \* 9/2012 Perez ..... D14/223  
 D669,881 S 10/2012 Clements et al.  
 8,290,193 B2 10/2012 Pang et al.  
 8,314,354 B2 \* 11/2012 Prest ..... H01H 13/7057  
 200/406  
 D681,001 S \* 4/2013 Murchison ..... D14/205  
 8,433,082 B2 4/2013 Abolfathi  
 D683,334 S \* 5/2013 Gondo ..... D14/223  
 8,447,062 B2 \* 5/2013 Lin ..... H04R 1/1033  
 381/370  
 D685,764 S \* 7/2013 Coulter ..... D14/205  
 D695,724 S 12/2013 Ishikura  
 8,611,581 B2 12/2013 Matsuo et al.  
 D698,750 S \* 2/2014 Yoon ..... D14/205  
 8,655,006 B2 \* 2/2014 Aase ..... B29C 43/203  
 381/370  
 8,712,087 B2 4/2014 Ozawa  
 D707,660 S 6/2014 Yang  
 8,743,533 B2 6/2014 Stanley  
 D712,371 S \* 9/2014 Henning ..... D14/205  
 D716,759 S 11/2014 Ha et al.  
 D721,673 S 1/2015 Park et al.  
 8,934,654 B2 1/2015 Fullam  
 D722,040 S 2/2015 Tan et al.  
 D726,145 S \* 4/2015 Hsieh ..... D14/205  
 D727,871 S \* 4/2015 Orbach ..... D14/205  
 9,031,264 B2 \* 5/2015 Yang ..... H04R 1/1033  
 381/189  
 D731,456 S \* 6/2015 Dahlberg ..... D14/205  
 D731,999 S 6/2015 Cepress et al.  
 D736,178 S 8/2015 Tsou  
 D737,251 S 8/2015 Thompson et al.  
 D743,381 S \* 11/2015 Pi ..... D14/218  
 D743,947 S 11/2015 Yoshimura  
 9,197,959 B2 11/2015 Fukushima et al.  
 D756,958 S 5/2016 Lee et al.  
 D756,959 S 5/2016 Lee et al.  
 D758,353 S \* 6/2016 Akana ..... D14/218  
 D762,196 S 7/2016 Hsieh et al.  
 D762,616 S 8/2016 Hsieh et al.  
 D766,189 S \* 9/2016 Gieski ..... D13/147  
 D771,010 S 11/2016 Louis  
 D775,108 S 12/2016 Hsieh et al.  
 D776,083 S \* 1/2017 Lee ..... D14/205  
 D776,635 S 1/2017 Chang et al.  
 D777,136 S 1/2017 Erbeus  
 D777,137 S 1/2017 Erbeus  
 D777,138 S \* 1/2017 Fletcher ..... D14/205  
 D777,139 S \* 1/2017 Fletcher ..... D14/205  
 D778,267 S 2/2017 Hsieh et al.  
 D780,155 S 2/2017 Levine et al.  
 D782,998 S \* 4/2017 Shin ..... D14/205  
 D786,217 S 5/2017 Stoch  
 D793,995 S \* 8/2017 Nakagawa ..... D14/218  
 D812,038 S \* 3/2018 Nakajima ..... D14/205  
 D816,059 S \* 4/2018 Liu ..... D14/205  
 D817,301 S \* 5/2018 Aoyagi ..... D14/205  
 9,980,032 B2 \* 5/2018 Yajima ..... H04R 1/1033

(56)

References Cited

U.S. PATENT DOCUMENTS

D820,810 S \* 6/2018 Levine ..... D14/205  
 D821,999 S \* 7/2018 Guo ..... D14/205  
 2010/0104126 A1\* 4/2010 Greene ..... H01B 7/225  
 381/384  
 2011/0142276 A1\* 6/2011 Uchida ..... H04R 1/1075  
 381/370  
 2012/0170789 A1\* 7/2012 Lin ..... H04R 1/1033  
 381/384  
 2013/0077815 A1\* 3/2013 Stephenson ..... H04R 1/1033  
 381/370  
 2013/0170692 A1 7/2013 Kaneko et al.  
 2016/0050487 A1 2/2016 Kim  
 2016/0142808 A1\* 5/2016 Monahan ..... H04R 1/105  
 381/384  
 2017/0295421 A1\* 10/2017 Hung ..... H04R 1/1016

FOREIGN PATENT DOCUMENTS

CN 303190103 4/2015  
 CN 303297640 7/2015  
 CN 303634597 4/2016  
 CN 303647619 4/2016  
 CN 303654967 4/2016  
 CN 303691284 6/2016  
 CN 303841127 9/2016  
 CN 304122715 S 1/2017

CN 304369242 S 11/2017  
 EM 003502681-0001 2/2017  
 JP D1322444 S 1/2008  
 JP 2013168981 A 8/2013  
 JP D1490815 1/2014  
 JP D1543469 S 2/2016  
 JP D1567615 S 12/2016  
 JP D1577262 S 4/2017  
 JP D1580978 S 7/2017  
 KR 30-0675093 1/2013  
 KR D 30-0796056 5/2015  
 KR 30-0825094 11/2015  
 KR 30-0842042 2/2016  
 KR D 30-0852003 4/2016

OTHER PUBLICATIONS

Chester Tan, Beoplay H3: Earphones Review, Online Review, Jun. 4, 2014.  
 Dime, Japanese Patent Office Document HA27001939, dated by JPO Apr. 16, 2015.  
 Japanese Patent Office Document HJ22045658, dated by JPO Oct. 5, 2010.  
 Japanese Patent Office Document HJ25015145, dated by JPO May 15, 2013.  
 Japanese Patent Office Document HJ25037202, dated by JPO Sep. 9, 2013.

\* cited by examiner

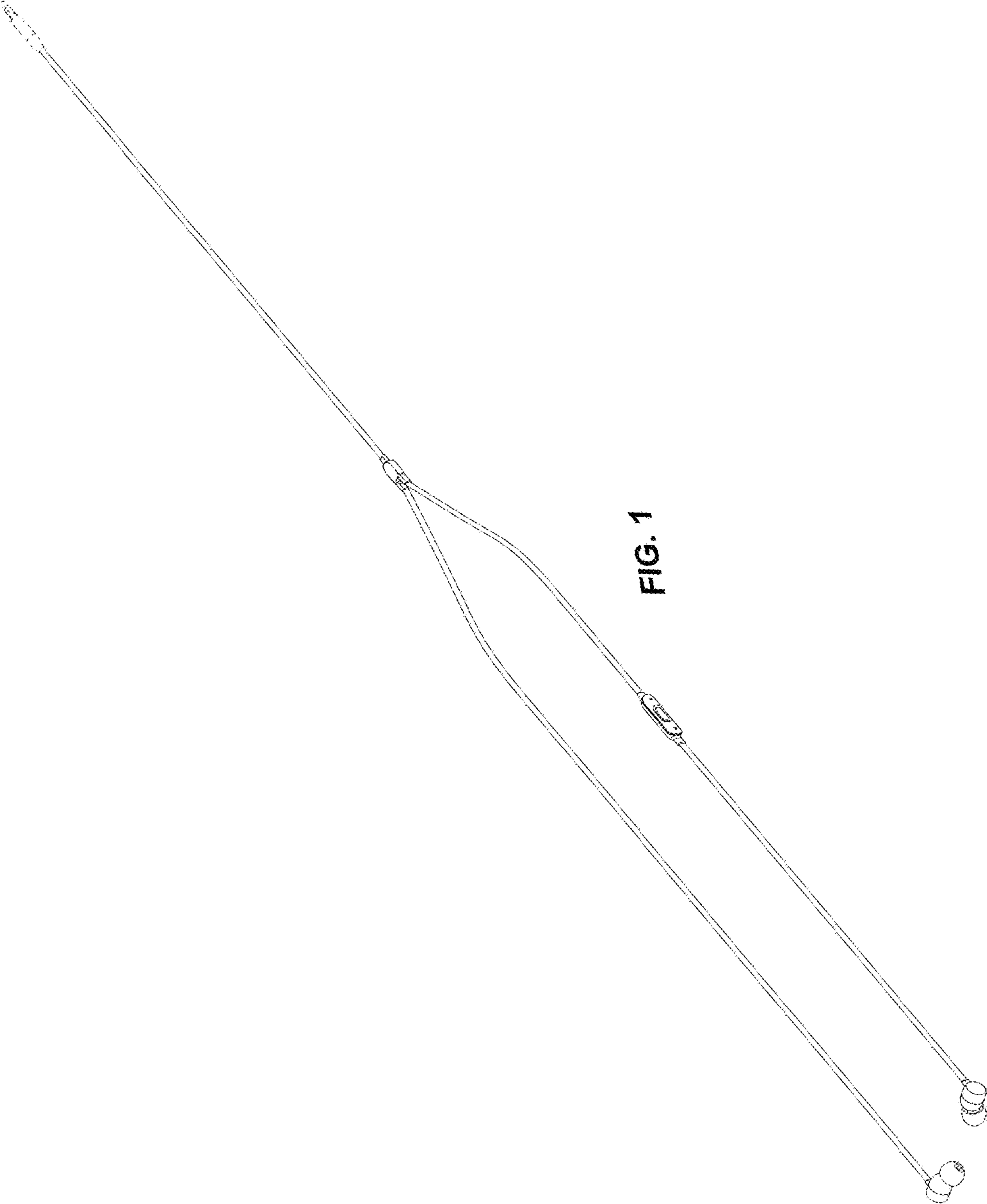

FIG. 1



FIG. 2



FIG. 3



FIG. 4

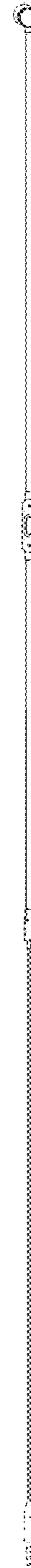

FIG. 5



FIG. 6

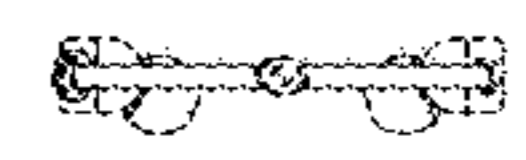

FIG. 7

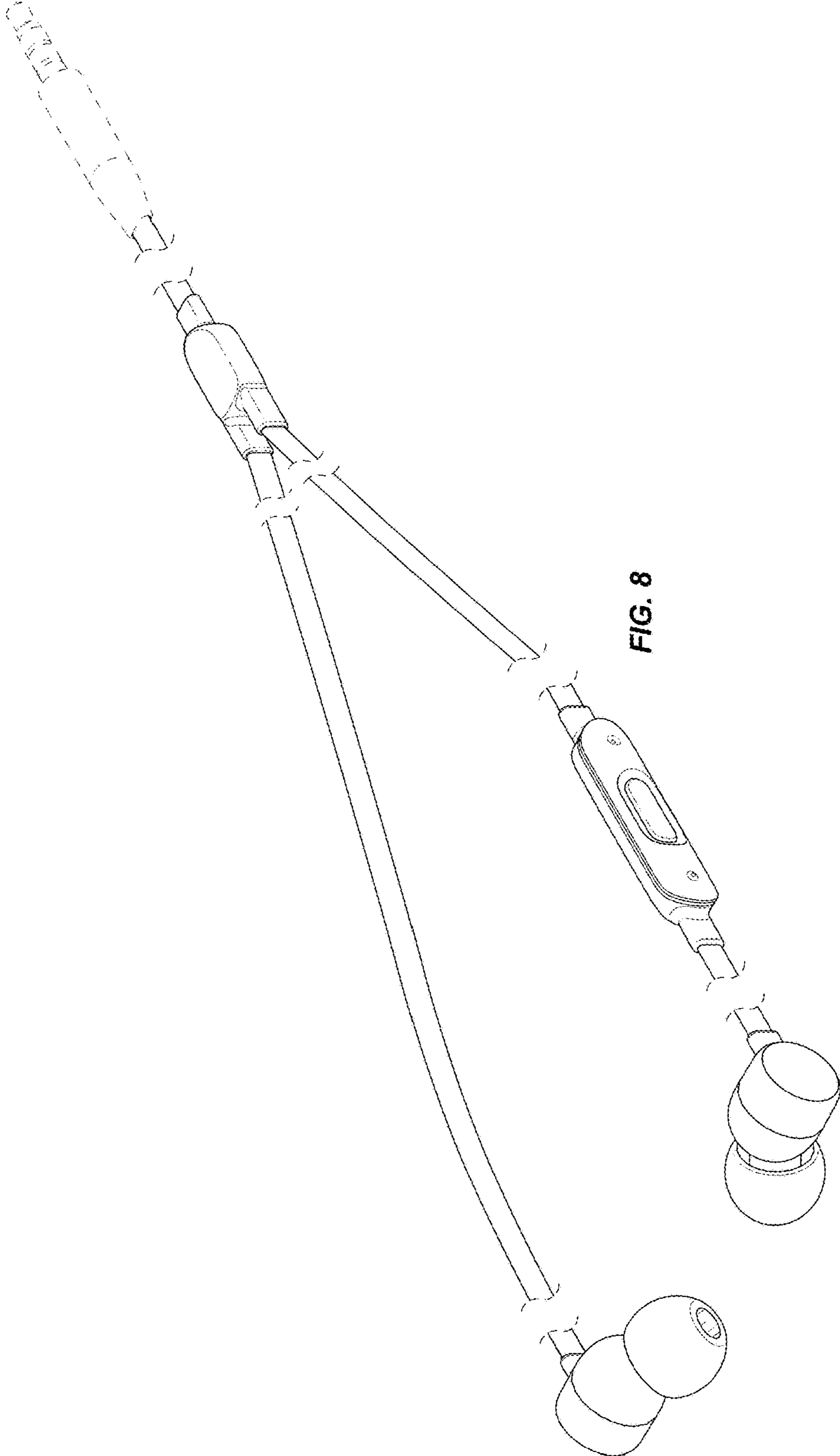

FIG. 8

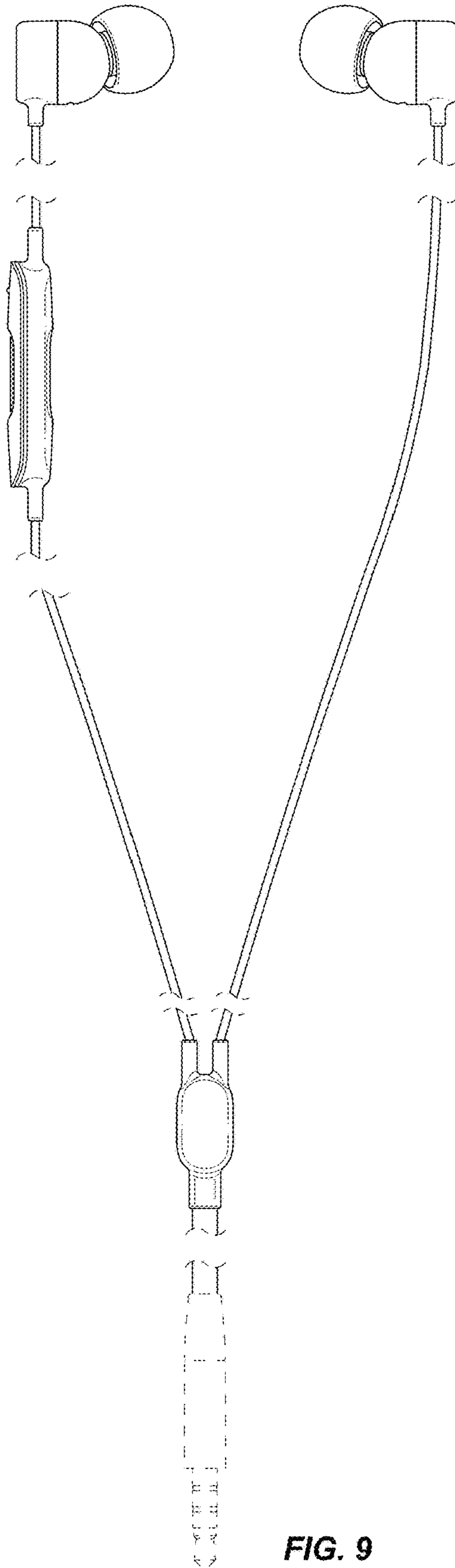

FIG. 9

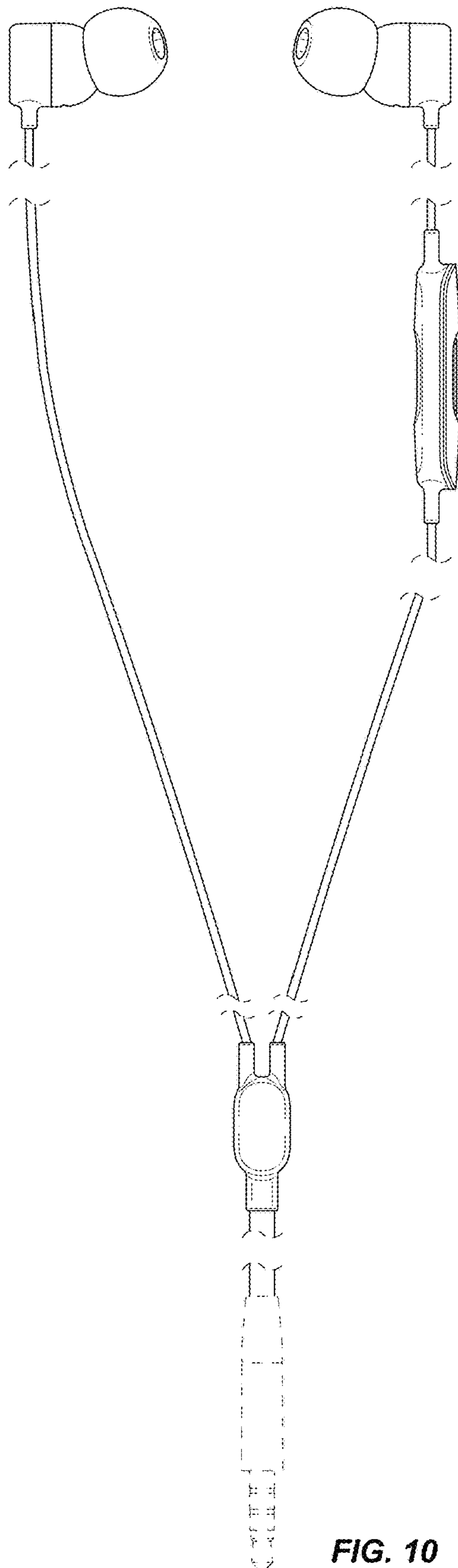

FIG. 10



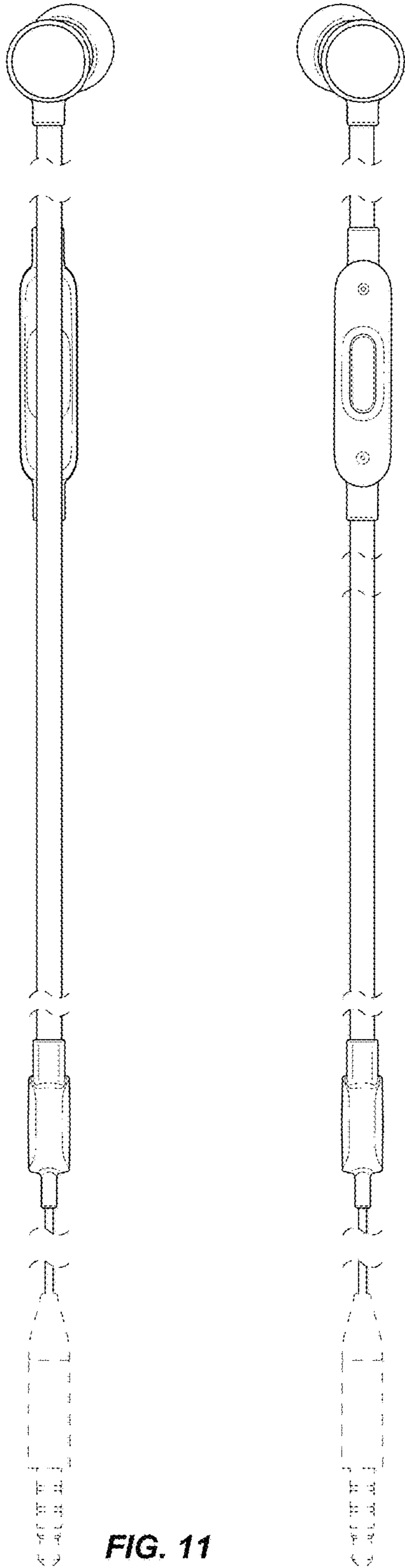

FIG. 11

FIG. 12

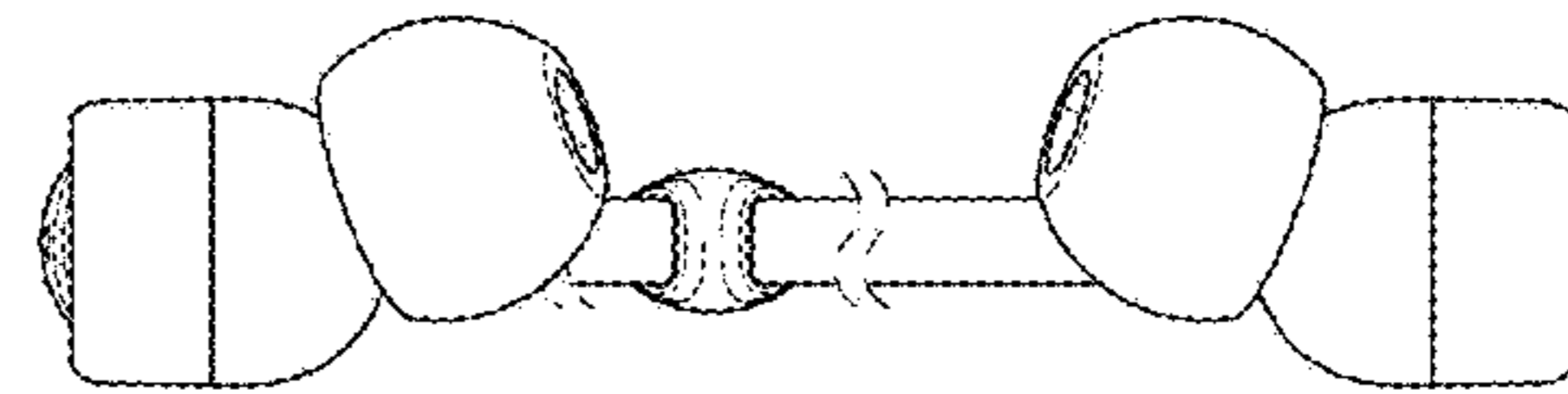

FIG. 13

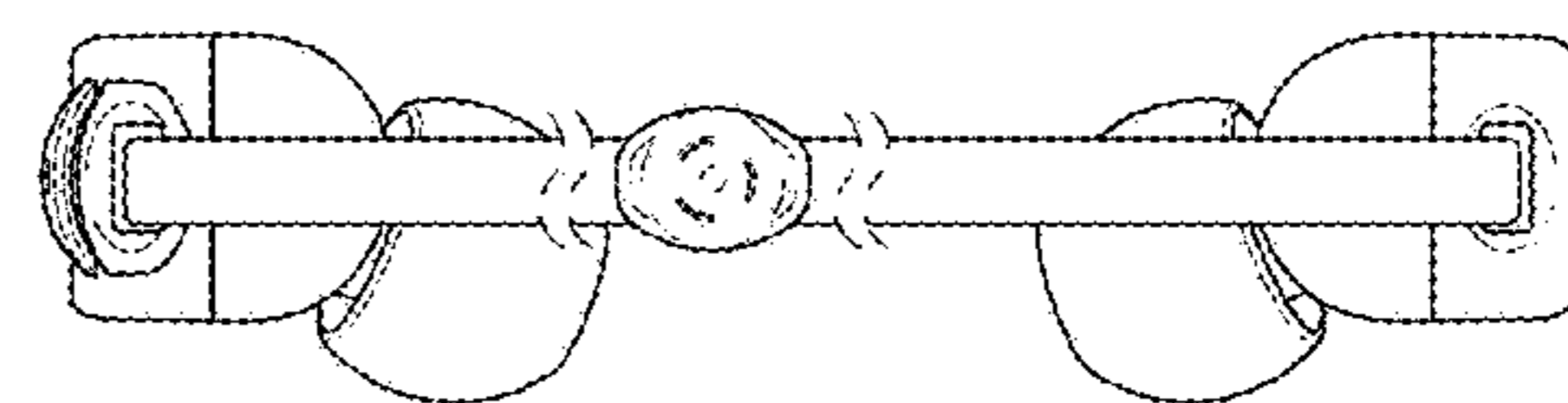

FIG. 14