



US00D845398S

(12) **United States Design Patent**
Wood

(10) **Patent No.:** **US D845,398 S**

(45) **Date of Patent:** **** Apr. 9, 2019**

(54) **PORTAL FOR A MODEL VEHICLE**

3,333,654 A 8/1967 Price
3,411,815 A 11/1968 Sullivan
3,498,622 A 3/1970 Belart

(Continued)

(71) Applicant: **TRAXXAS LP**, McKinney, TX (US)

(72) Inventor: **Jonathan Scott Wood**, Lewisville, TX (US)

(73) Assignee: **TRAXXAS LP**, McKinney, TX (US)

(**) Term: **15 Years**

(21) Appl. No.: **29/592,279**

(22) Filed: **Jan. 27, 2017**

(51) **LOC (11) Cl.** **21-01**

(52) **U.S. Cl.**
USPC **D21/495**

(58) **Field of Classification Search**
USPC D21/495, 561, 562; 446/103;
280/124.155, 124.139; D12/159, 180;
D15/5, 148, 149
CPC A63H 33/042; A63H 3/16; A63H 30/00;
A63H 7/04; A63H 31/00; A63H 3/50;
A63H 17/26; A63H 17/36; A63H 17/262;
A63H 17/264
See application file for complete search history.

(56) **References Cited**

U.S. PATENT DOCUMENTS

1,377,905 A	5/1921	Martz
1,455,706 A	5/1923	Bower et al.
1,641,224 A	9/1927	Gurney
2,041,992 A	5/1936	Noel
2,083,085 A	6/1937	Marley
2,132,545 A	10/1938	Smith
2,285,445 A	6/1942	Alwin
2,547,435 A	4/1951	Bouchard
2,631,044 A	3/1953	Booth
2,926,938 A	3/1960	Ratti
2,993,716 A	7/1961	Viktor
3,306,077 A	2/1967	Piatti

OTHER PUBLICATIONS

Xray; "T1R Raycer-Instruction Manual;" Xray Model Racing Cars, Trencin, Slovak Republic, Europe.

(Continued)

Primary Examiner — Robin V Webster

Assistant Examiner — Keith J Wilson

(74) *Attorney, Agent, or Firm* — Daryl R. Wright; Greg Carr

(57) **CLAIM**

I claim the ornamental design for a portal for a model vehicle, as shown and described.

DESCRIPTION

FIG. 1 is an upper, right, rear perspective view of a portal for a model vehicle;
FIG. 2 is an upper, left, front perspective view thereof;
FIG. 3 is a left side elevation view thereof;
FIG. 4 is a right side elevation view thereof;
FIG. 5 is a front elevation view thereof;
FIG. 6 is a rear elevation view thereof;
FIG. 7 is a top plan view thereof;
FIG. 8 is a bottom plan view thereof; and,
FIG. 9 is a reduced scale environmental bottom, left, front perspective view of a portal for a model vehicle mounted on a model vehicle platform.

In the drawings, the broken line showing of features of the portal for a model vehicle illustrates portions of portal for a model vehicle that forms no part of the claimed design; whereas, the broken line showing of the environmental use view depicts environmental subject matter and is provided for the purposes of illustrating environmental use structure and context and forms no part of claimed design.

1 Claim, 5 Drawing Sheets

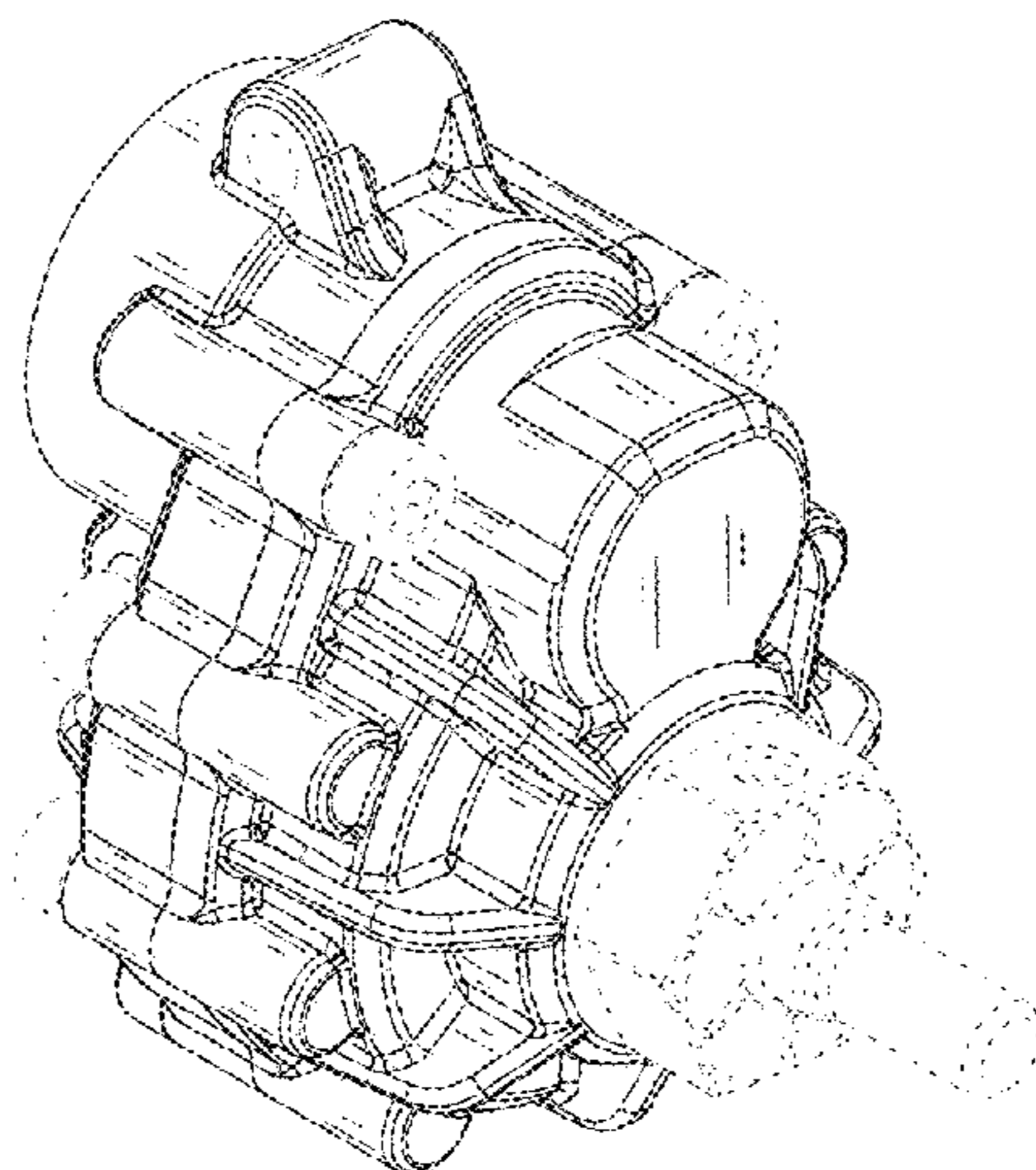
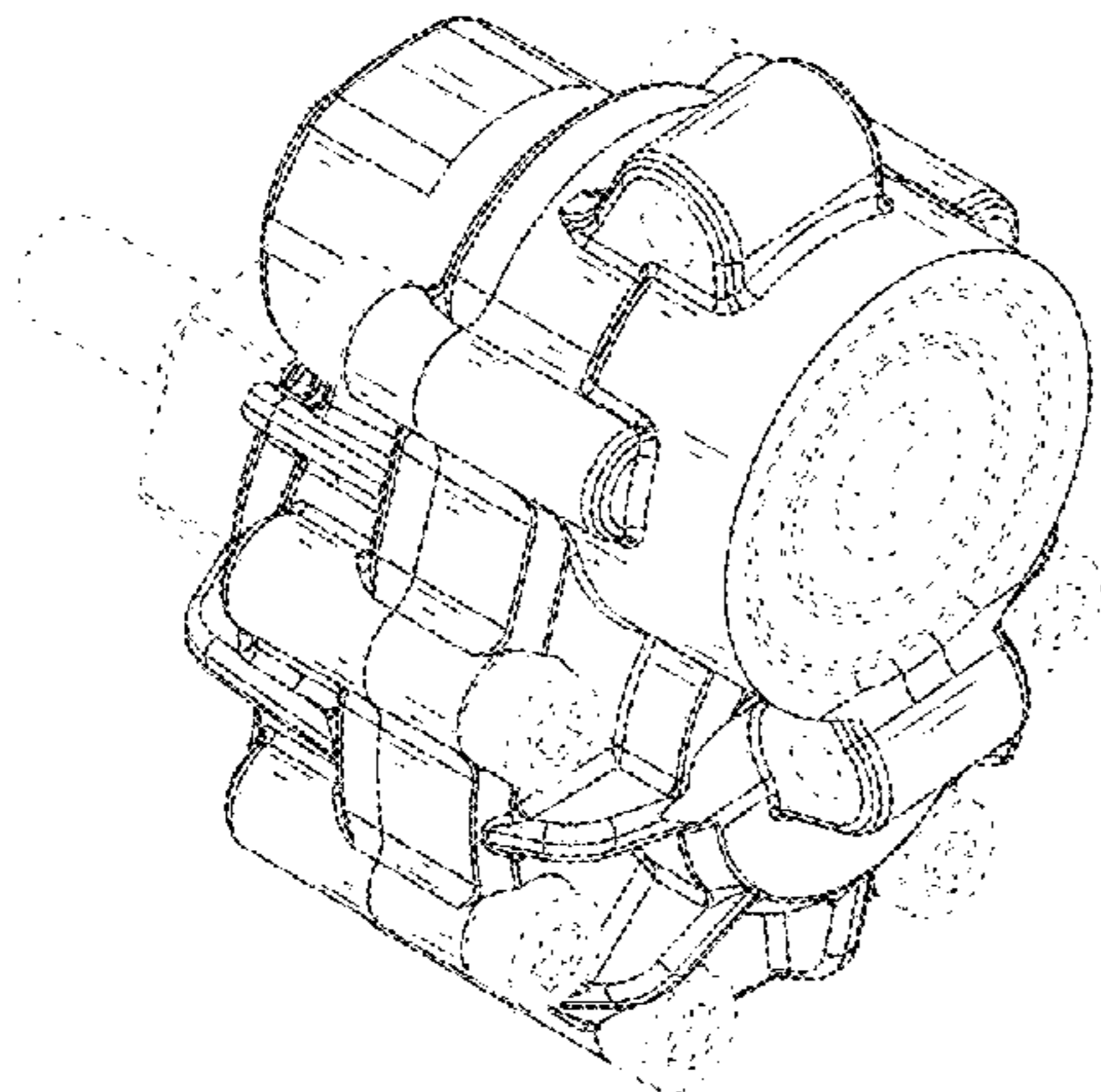

(56)

References Cited

U.S. PATENT DOCUMENTS

3,767,221 A 10/1973 Asberg
 3,858,412 A 1/1975 Fisher et al.
 4,111,571 A 9/1978 Farrant
 4,509,932 A 4/1985 Weible
 4,540,385 A 9/1985 Krude
 4,632,203 A 12/1986 Krude
 5,230,660 A 7/1993 Warnke
 5,498,208 A 3/1996 Braun
 5,615,967 A 4/1997 Hellon
 5,653,547 A 8/1997 Teremachi et al.
 5,954,586 A 9/1999 Kirson
 6,416,136 B1 7/2002 Smith
 6,513,614 B2 2/2003 Knutson et al.
 6,676,527 B2 1/2004 Kudo et al.
 6,773,353 B2 8/2004 Cornay et al.
 6,783,136 B2 8/2004 Timoney et al.
 6,820,707 B1 11/2004 Cantemir
 6,869,244 B2 3/2005 Anderton et al.
 7,144,326 B2 12/2006 Thompson
 7,234,715 B2 6/2007 Downs et al.
 7,810,604 B2 10/2010 Byers et al.
 8,052,345 B2 11/2011 Byers et al.
 D771,147 S * 11/2016 Fisher D15/5
 D775,252 S * 12/2016 Shentu D15/149
 D776,719 S * 1/2017 Fisher D15/5
 D779,560 S * 2/2017 Fox D15/5
 D779,561 S * 2/2017 Fox D15/5
 D808,872 S * 1/2018 Cecur D12/180
 2002/0163151 A1 11/2002 Timoney et al.

2002/0165031 A1 11/2002 Riefe
 2004/0005931 A1 1/2004 Wang et al.
 2004/0231910 A1 11/2004 Mercier et al.
 2006/0240897 A1 10/2006 Carlini et al.
 2007/0293328 A1 12/2007 Mazziotti

OTHER PUBLICATIONS

Traxxas; "T-MAXX Assemblies-Front Assembly;" Traxxas LP, Plano, Texas.
 Mercedes Benz, Ball Joint, 1 photograph.
 Samarins, CV Joint Boot, Apr. 25, 2006; http://www.samarins.com/glossary/cv_joint.html; 1 photograph.
 Wikipedia; Portal Axle; https://en.wikipedia.org/wiki/Portal_axle; Aug. 2016.
 Mercedes; G-Class Squared; <https://www.mercedes-benz.com/en/mercedes-benz/vehicles/passenger-cars/g-class/the-g-class-squared/>; Aug. 2016.
 Wikipedia; Unimog; <https://en.wikipedia.org/wiki/Unimog>; Aug. 2016.
 Tibus Bolt-On Portals; <http://www.tibus-offroad.com/en/products/bolt-on-portals/>; Aug. 2016.
 Four Wheeler Network; Living with Mopar Portal Axles; <http://www.fourwheeler.com/how-to/transmission-drivetrain/131-1208-living-with-mopar-portal-axles/>; Aug. 2016.
 Gmade R1; http://gmade.net/dealer/index.php?main_page=product_info&products_id=427; Aug. 2016.
 Associated Electrics; "Catalog and parts listing for the Monster GT Truck;" 2003; Associated Electric, Inc., Costa Mesa, CA.

* cited by examiner

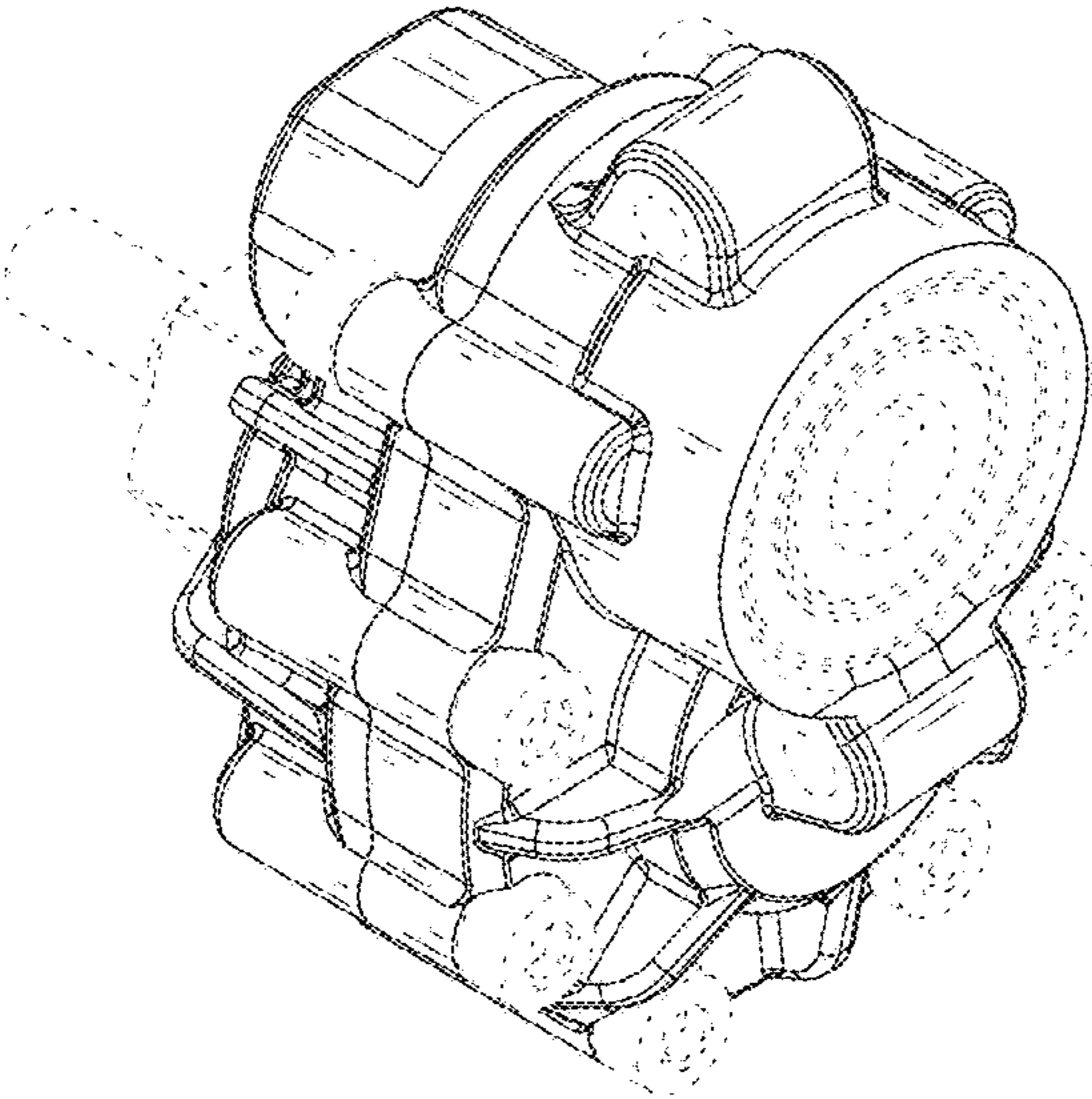

FIG. 1

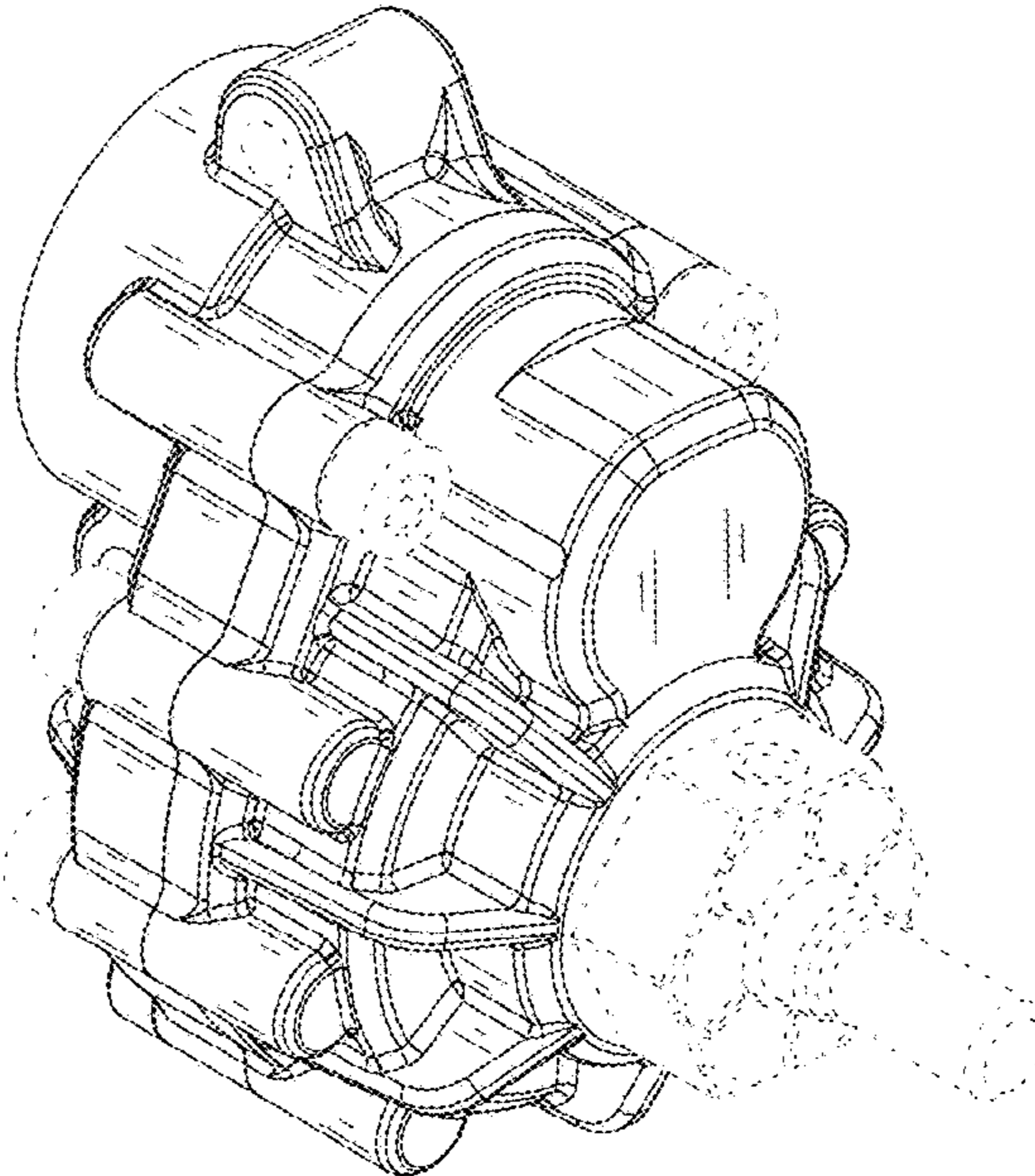

FIG. 2

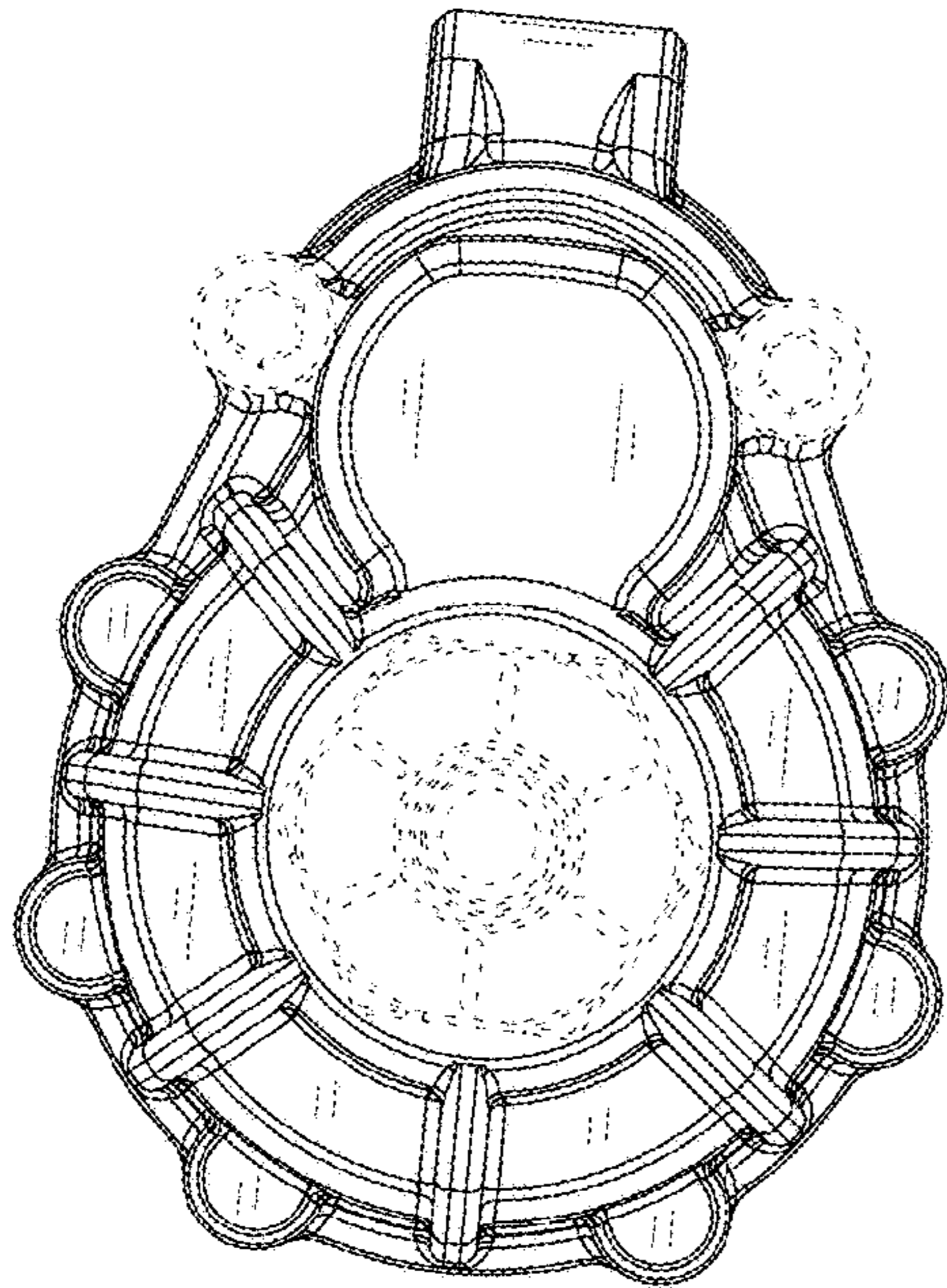

FIG. 3

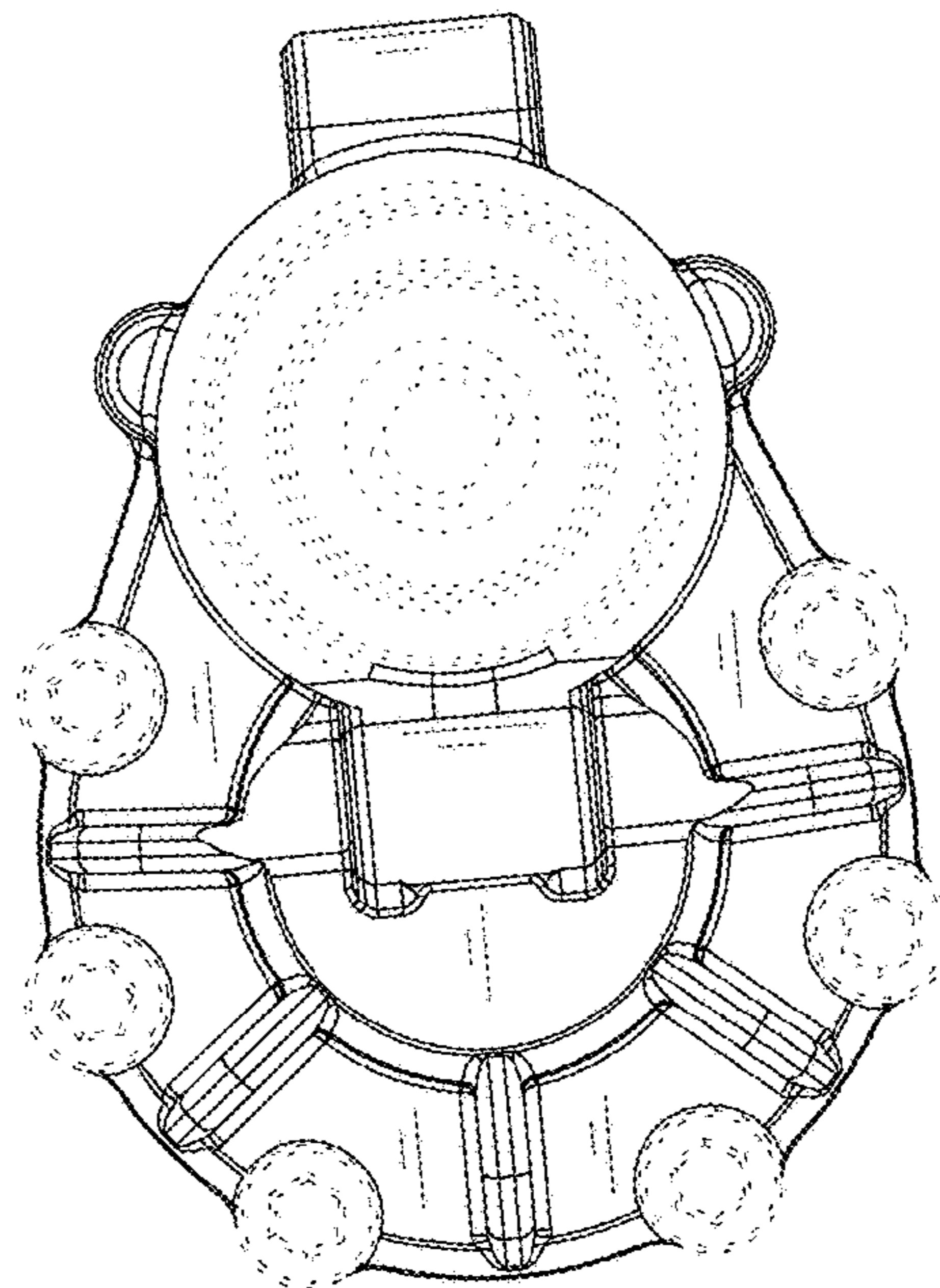

FIG. 4

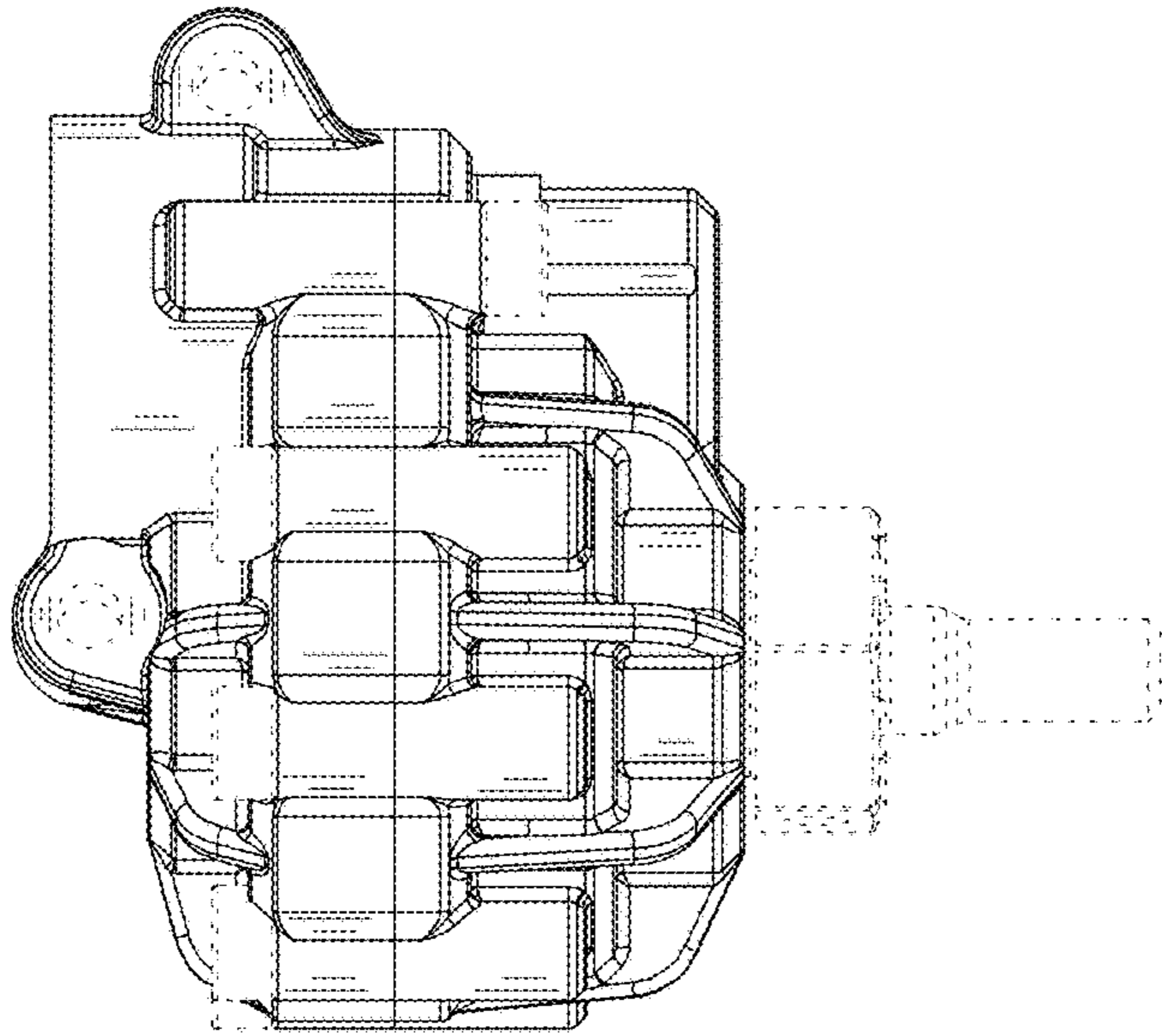

FIG. 5

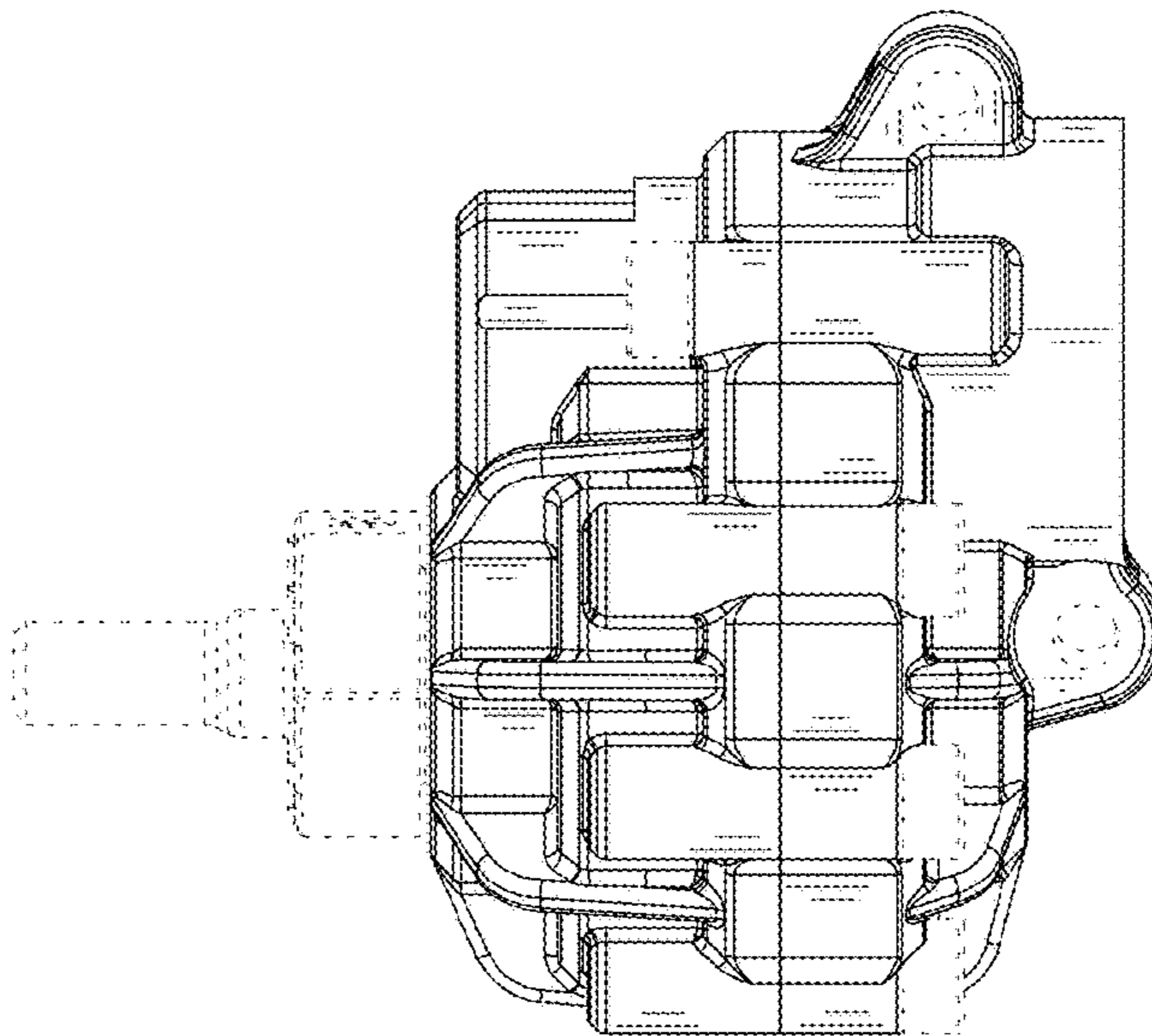

FIG. 6

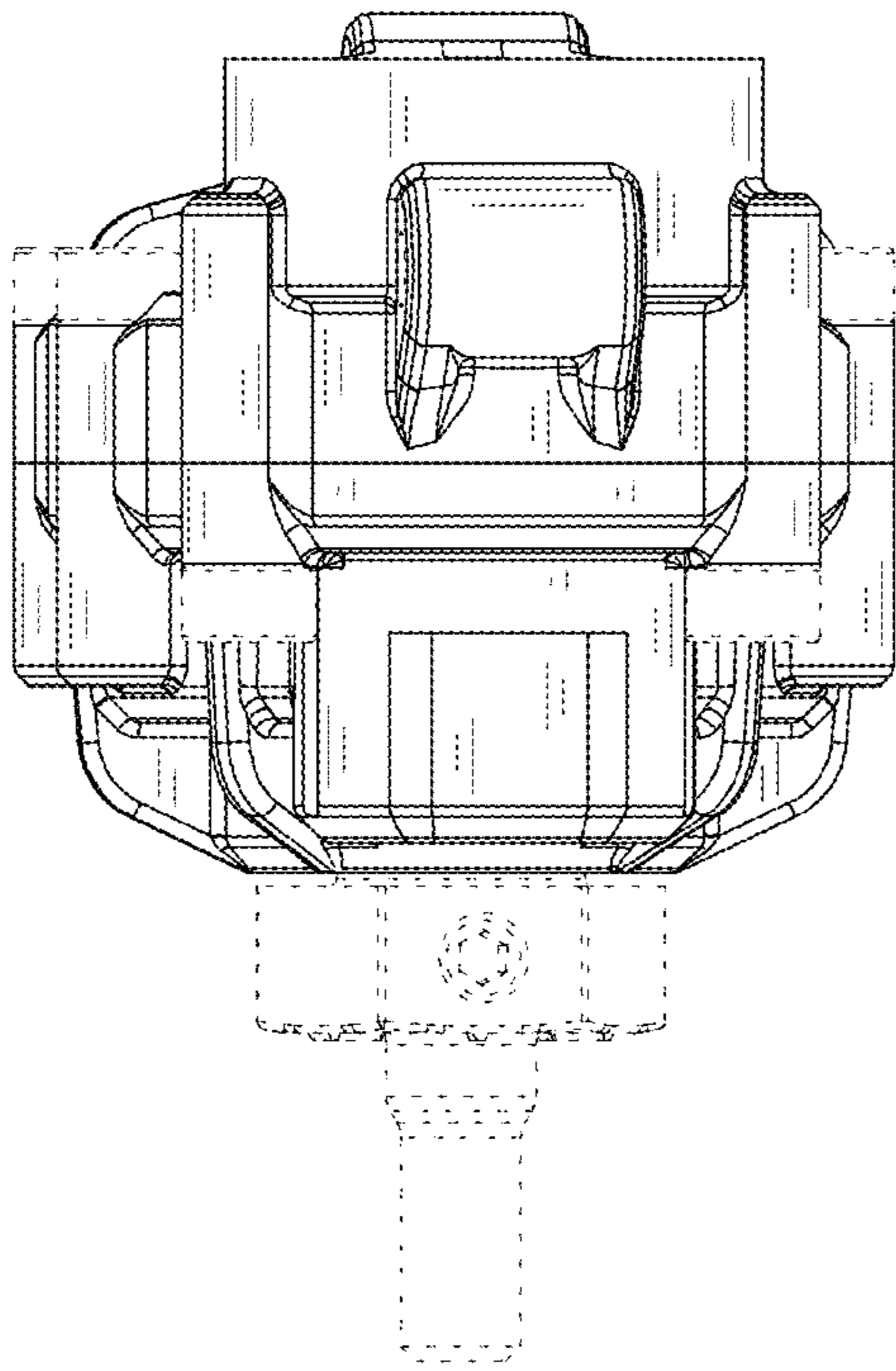

FIG. 7

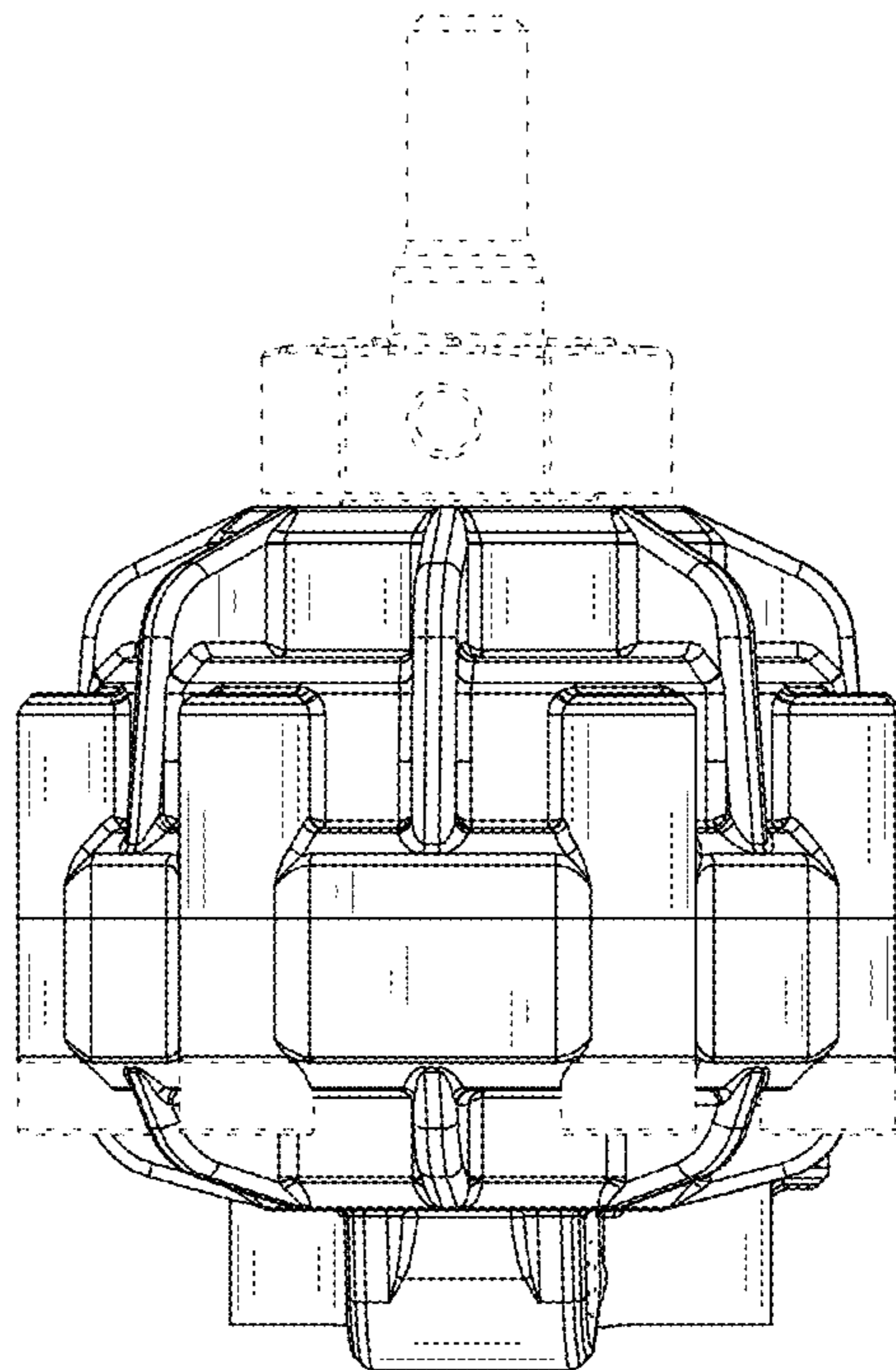

FIG. 8

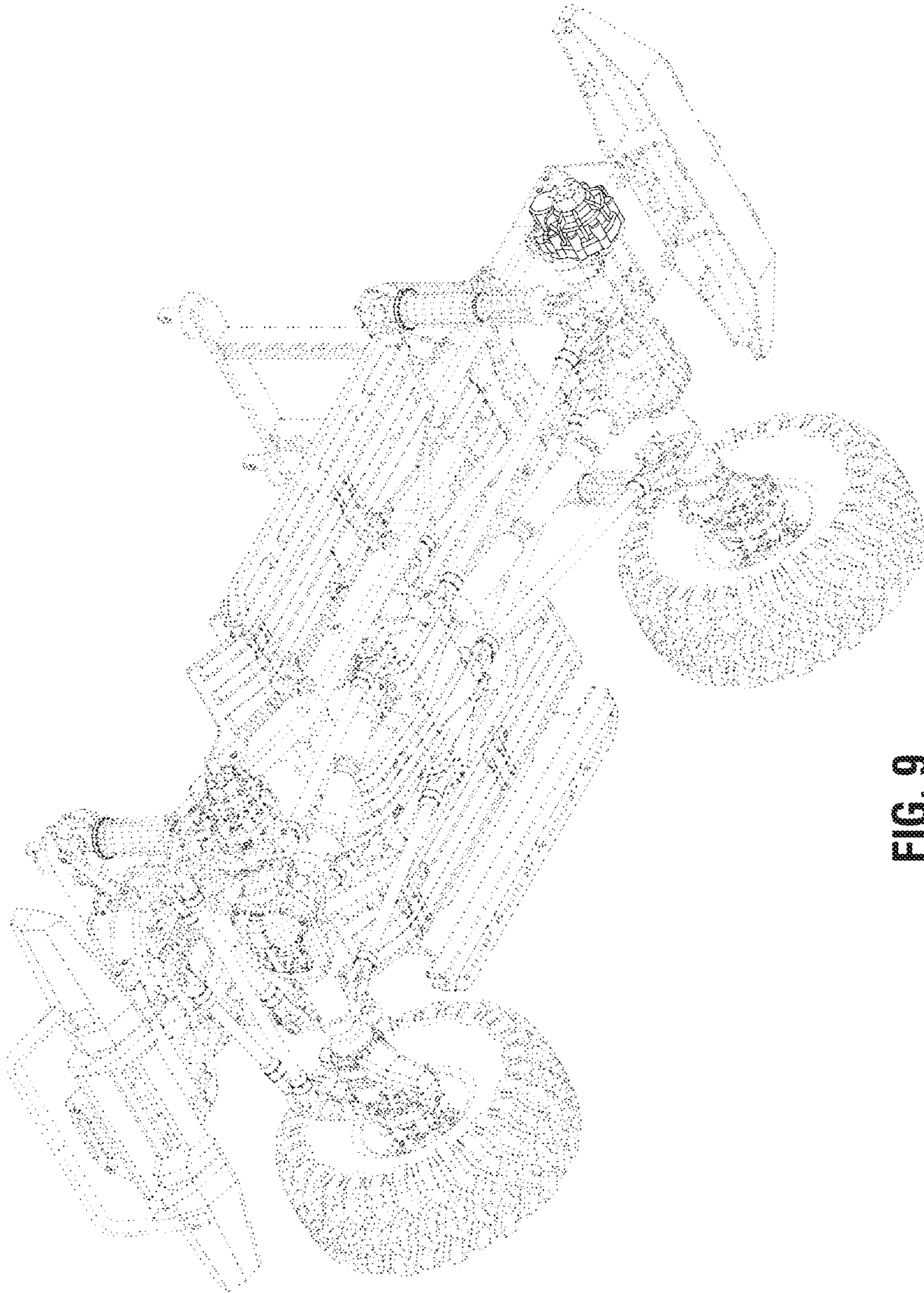

FIG. 9