



US00D845351S

(12) **United States Design Patent** (10) **Patent No.:** **US D845,351 S**
Yamaguchi et al. (45) **Date of Patent:** **** Apr. 9, 2019**

(54) **COVER FOR WATER PUMP**

(71) Applicant: **AISIN SEIKI KABUSHIKI KAISHA,**
Aichi-Ken (JP)

(72) Inventors: **Wataru Yamaguchi,** Kariya (JP);
Takayuki Fujita, Kariya (JP)

(73) Assignee: **AISIN SEIKI KABUSHIKI KAISHA,**
Kariya-Shi, Aichi-Ken (JP)

(**) Term: **15 Years**

(21) Appl. No.: **35/504,476**

(22) Filed: **Aug. 23, 2017**

(80) **Hague Agreement Data**
 Int. Filing Date: **Aug. 23, 2017**
 Int. Reg. No.: **DM/097462**
 Int. Reg. Date: **Aug. 23, 2017**
 Int. Reg. Pub. Date: **Feb. 23, 2018**

D461,828 S * 8/2002 Sodergard D15/7
 D461,829 S * 8/2002 Sodergard D15/7
 D487,471 S * 3/2004 Rivera D15/7
 D494,192 S * 8/2004 Hirakawa D15/7
 D507,578 S * 7/2005 Hirakawa D15/7
 D520,026 S * 5/2006 Hulks D15/9
 D531,643 S * 11/2006 Tischler D15/7
 D548,751 S * 8/2007 Snider D15/7
 D552,139 S * 10/2007 Cho D15/199
 D575,802 S * 8/2008 Chu D15/9
 D589,060 S * 3/2009 Metcalfe D15/7
 D602,501 S * 10/2009 Ton D15/7
 D607,014 S * 12/2009 Stimpson D15/7
 D611,504 S * 3/2010 Ton D15/7
 D618,706 S * 6/2010 Coleman D15/7
 D648,747 S * 11/2011 McCombs D15/9
 D649,561 S * 11/2011 Bauck D15/7

(Continued)

Primary Examiner — Richard E Chilcot
 (74) *Attorney, Agent, or Firm* — Buchanan Ingersoll &
 Rooney PC

(30) **Foreign Application Priority Data**
 Feb. 24, 2017 (JP) 2017-003668

(51) **LOC (11) Cl.** **15-02**

(52) **U.S. Cl.**
 USPC **D15/7**
 CPC **F02M 37/04** (2013.01)

(58) **Field of Classification Search**
 USPC D7/7-9; D23/225, 231, 232; 417/60,
 417/235, 265, 321, 355, 358, 363, 359,
 417/410.1, 415, 416, 405, 900;
 60/408-412; 184/26-37; 415/140-147,
 415/127; 123/495, 509; 137/565.34
 CPC F02M 37/14; F02B 75/07
 See application file for complete search history.

(57) **CLAIM**

The ornamental design for a cover for water pump, as shown and described.

DESCRIPTION

- 1. Cover for water pump
- 1.1 : Front perspective view
- 1.2 : Back perspective view
- 1.3 : Front
- 1.4 : Top
- 1.5 : Bottom
- 1.6 : Right
- 1.7 : Left

The present article relates to a cover for water pump attached to a housing of an automobile engine; the fine lines on the surface of the article in each view depict three-dimensional shape of the surface; the broken lines in the drawings form no part of the claimed design; the dashed-dotted lines represent the unclaimed boundaries.

(56) **References Cited**
 U.S. PATENT DOCUMENTS
 D249,264 S * 9/1978 Bingler D15/7
 D382,882 S * 8/1997 Parker D15/7

1 Claim, 7 Drawing Sheets

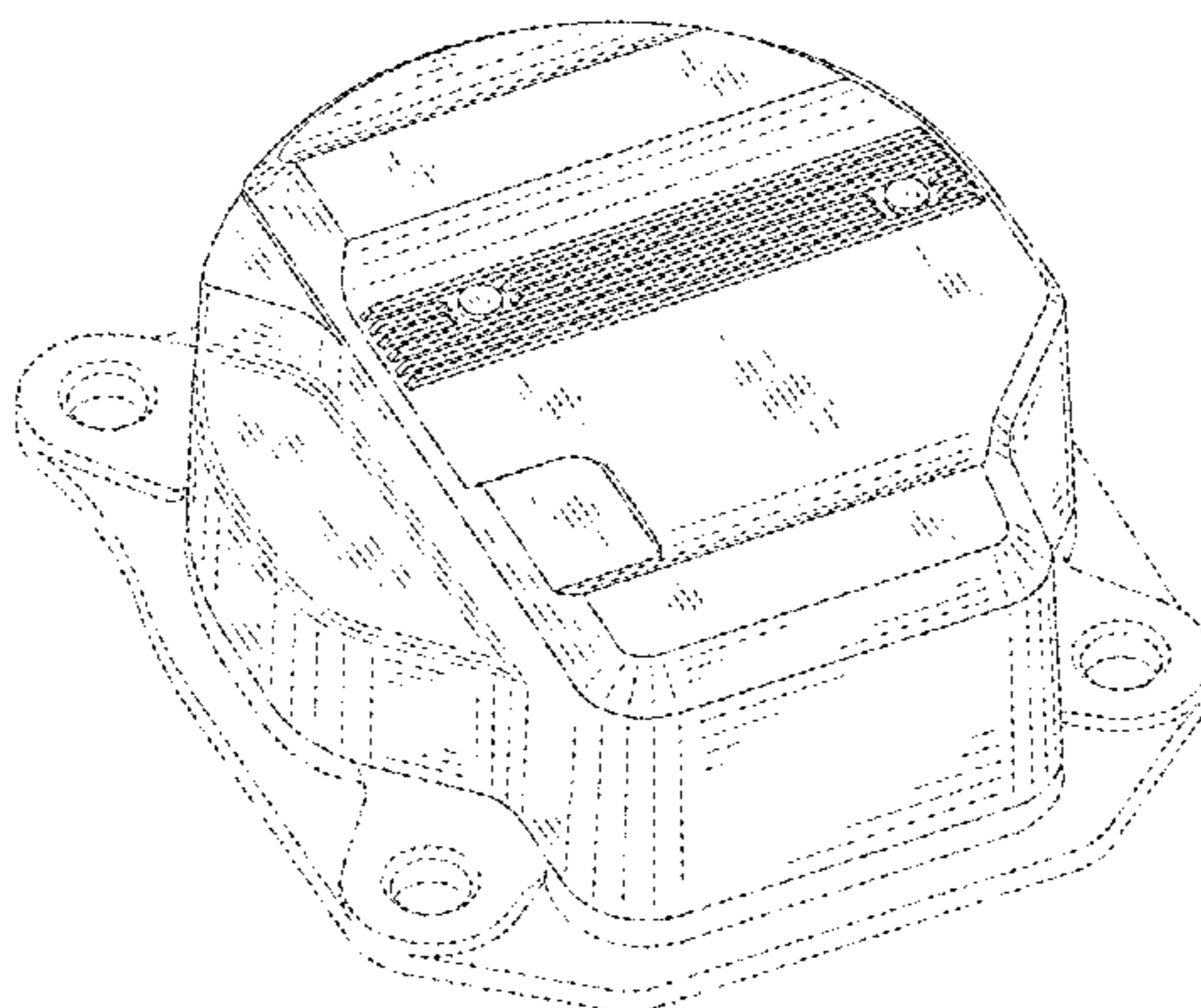

(56)

References Cited

U.S. PATENT DOCUMENTS

D659,715	S	*	5/2012	Seidel	D15/7
D669,096	S	*	10/2012	Katsura	D15/7
D673,584	S	*	1/2013	Nam	D15/7
D682,886	S	*	5/2013	Haider	D15/7
D693,371	S	*	11/2013	Orsini	D15/7
D693,850	S	*	11/2013	Haider	D15/7
D698,368	S	*	1/2014	Le	D15/7
D706,834	S	*	6/2014	Nowicki	D15/9
D707,718	S	*	6/2014	Gomez	D15/7
D709,920	S	*	7/2014	Tristano	D15/7
D722,328	S	*	2/2015	Sarder	D15/7
D744,003	S	*	11/2015	Ton	D15/7
D788,178	S	*	5/2017	Theiss	D15/7
D788,932	S	*	6/2017	Ton	D24/201
D793,454	S	*	8/2017	Perez	D15/7
D819,085	S	*	5/2018	Ferguson	D15/7
D823,345	S	*	7/2018	Wilds	D15/7

* cited by examiner

1.1

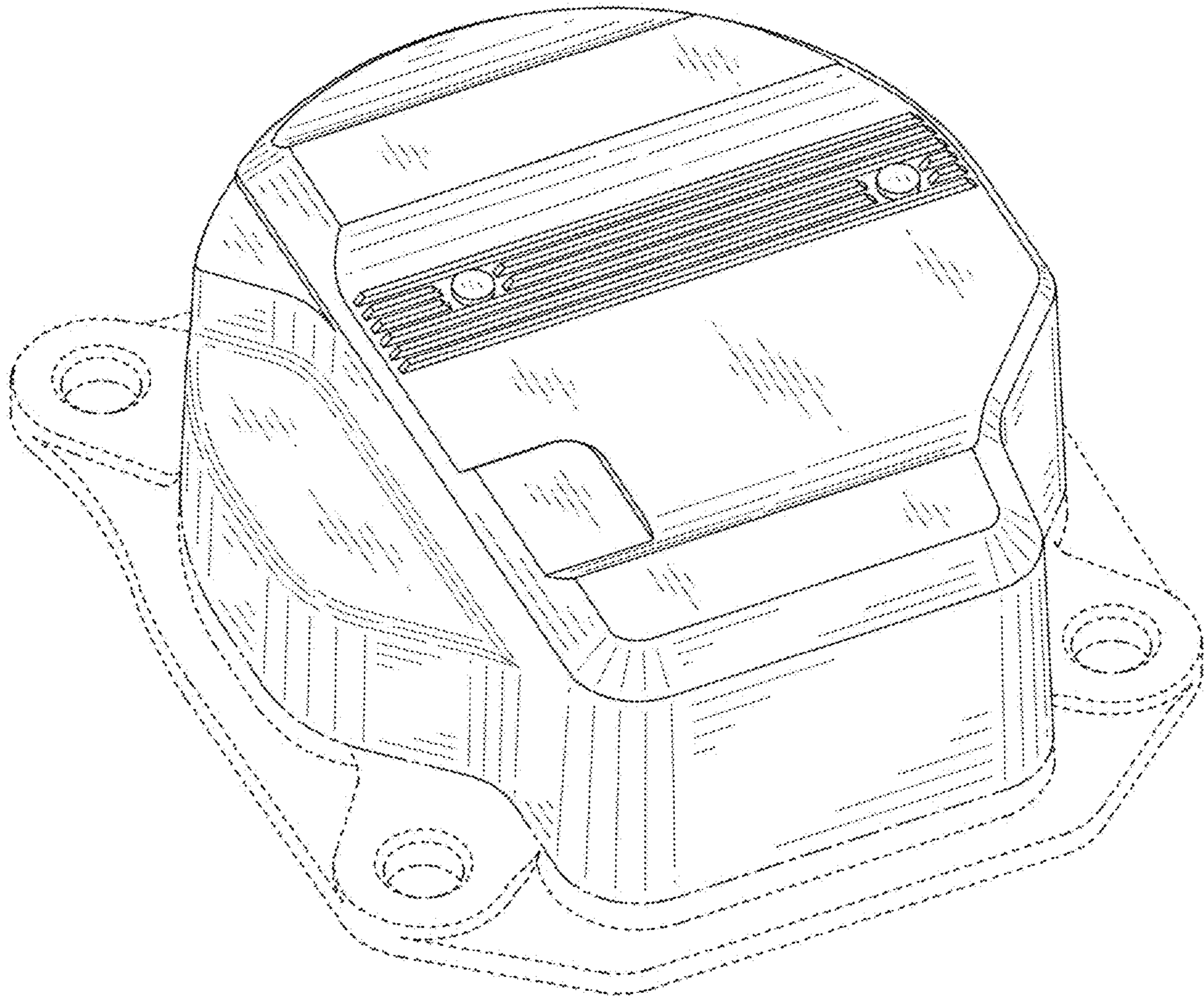

1.2

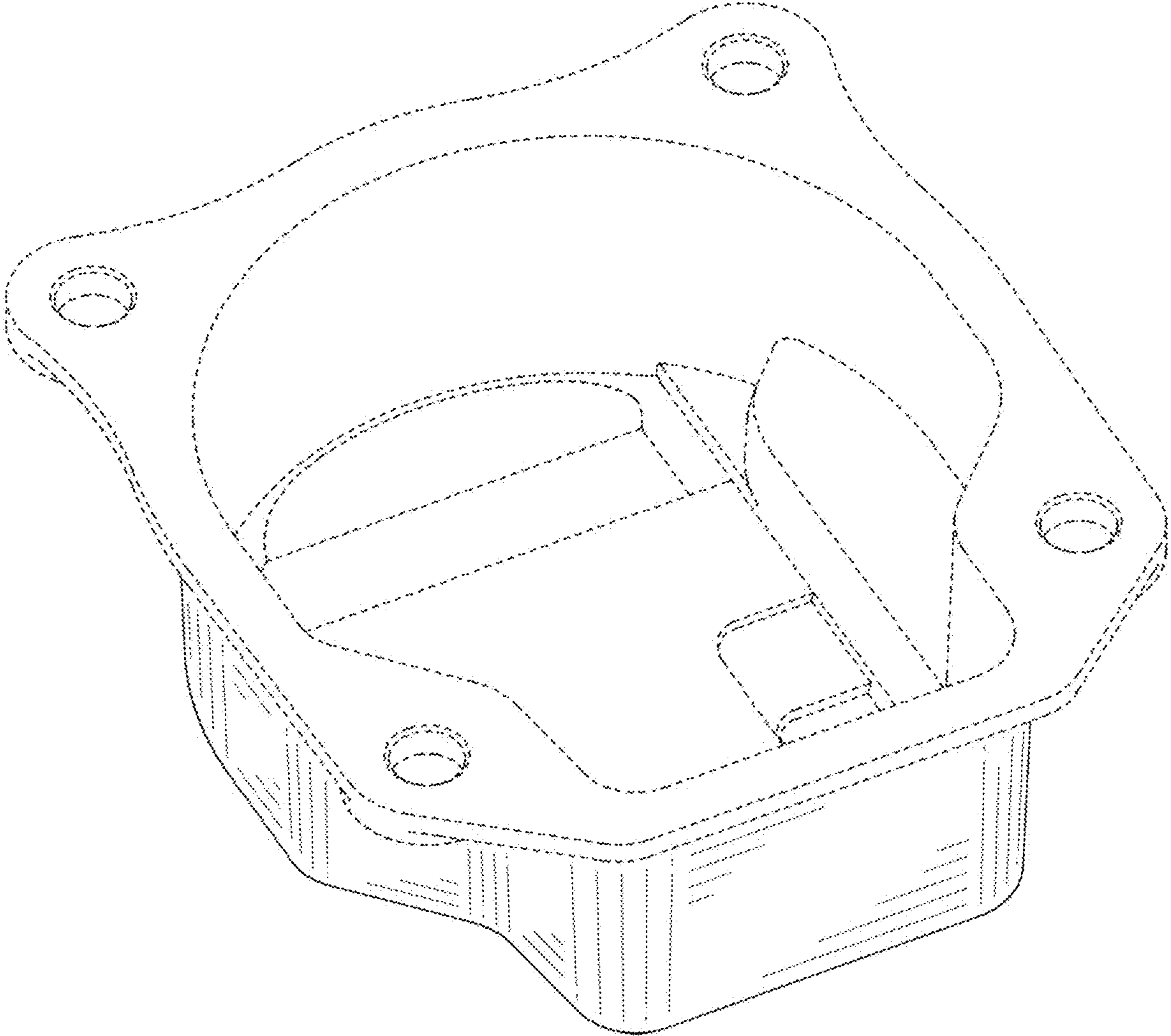

1.3

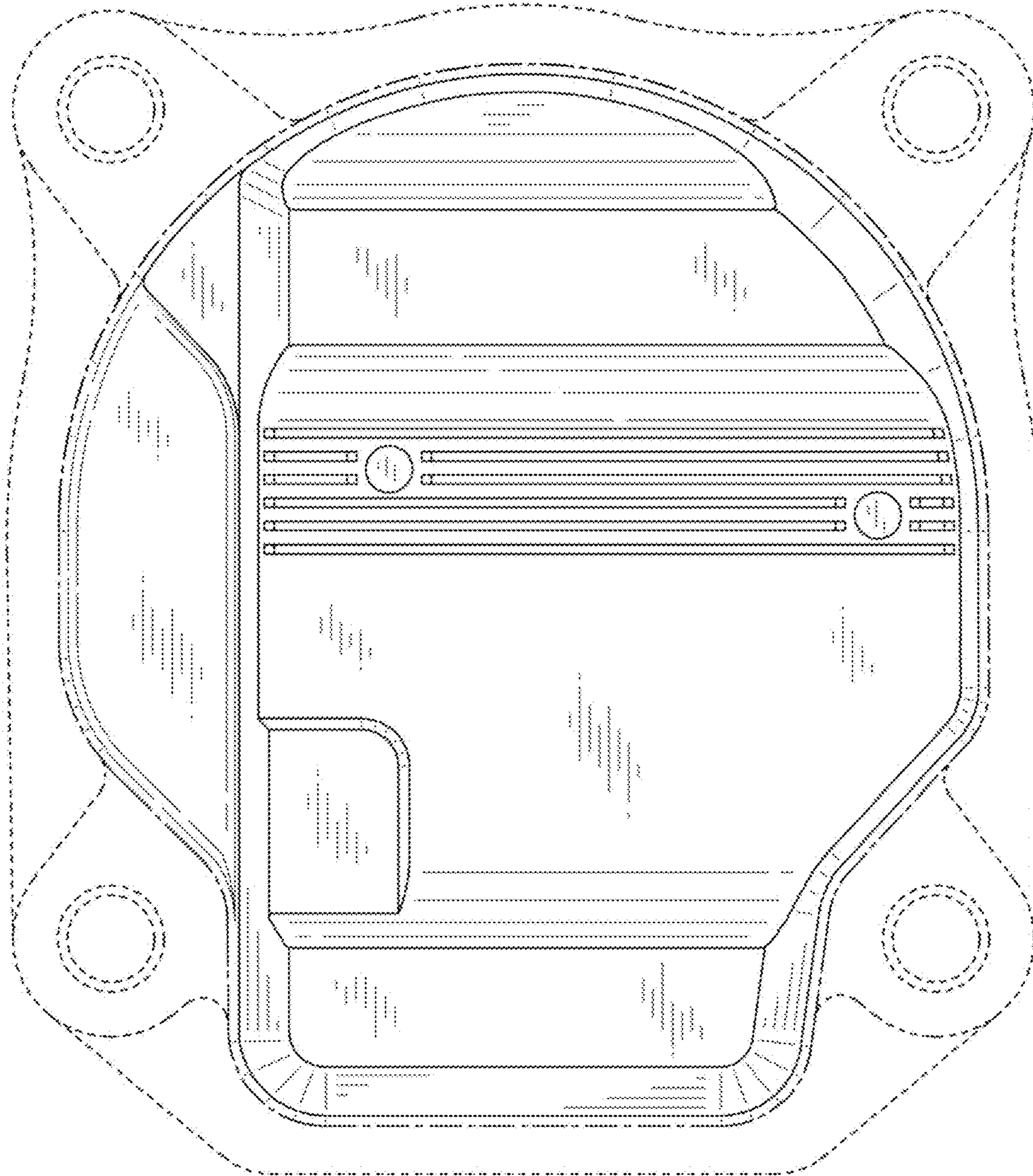

1.4

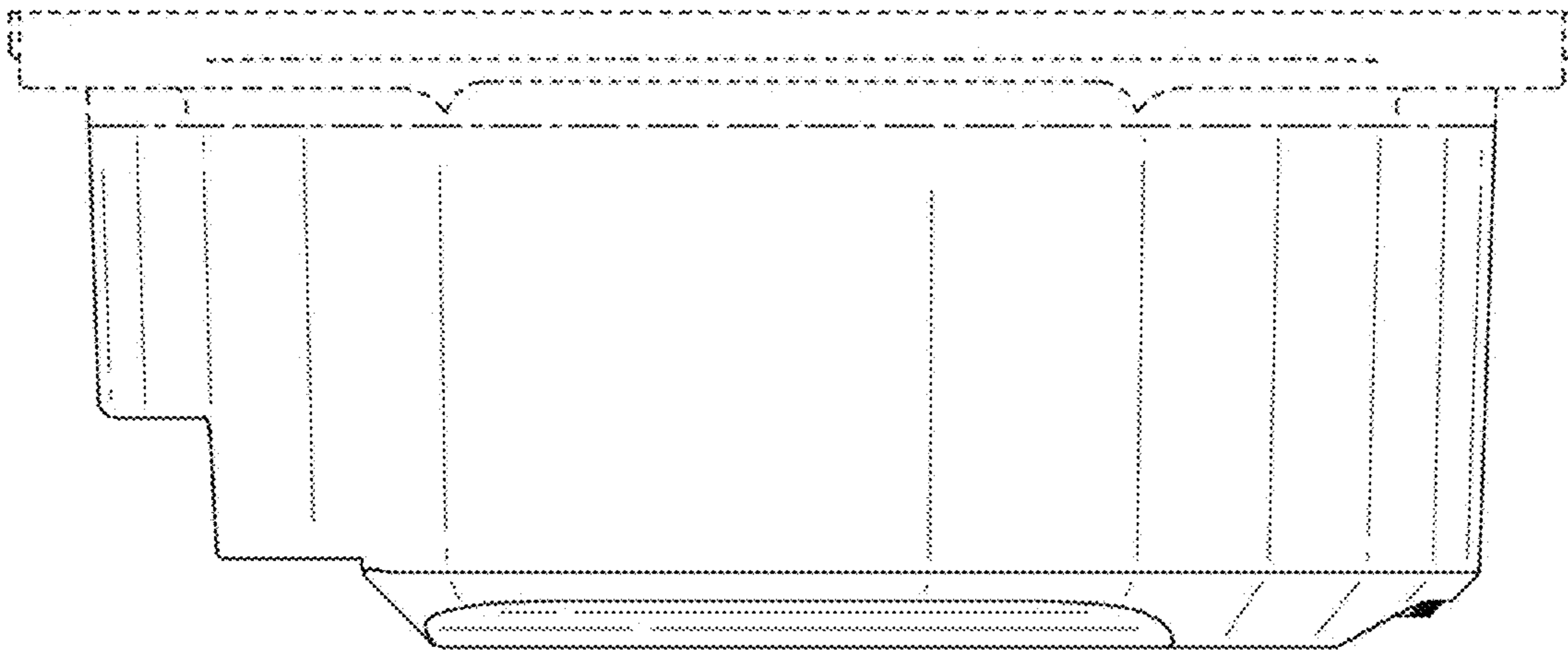

1.5

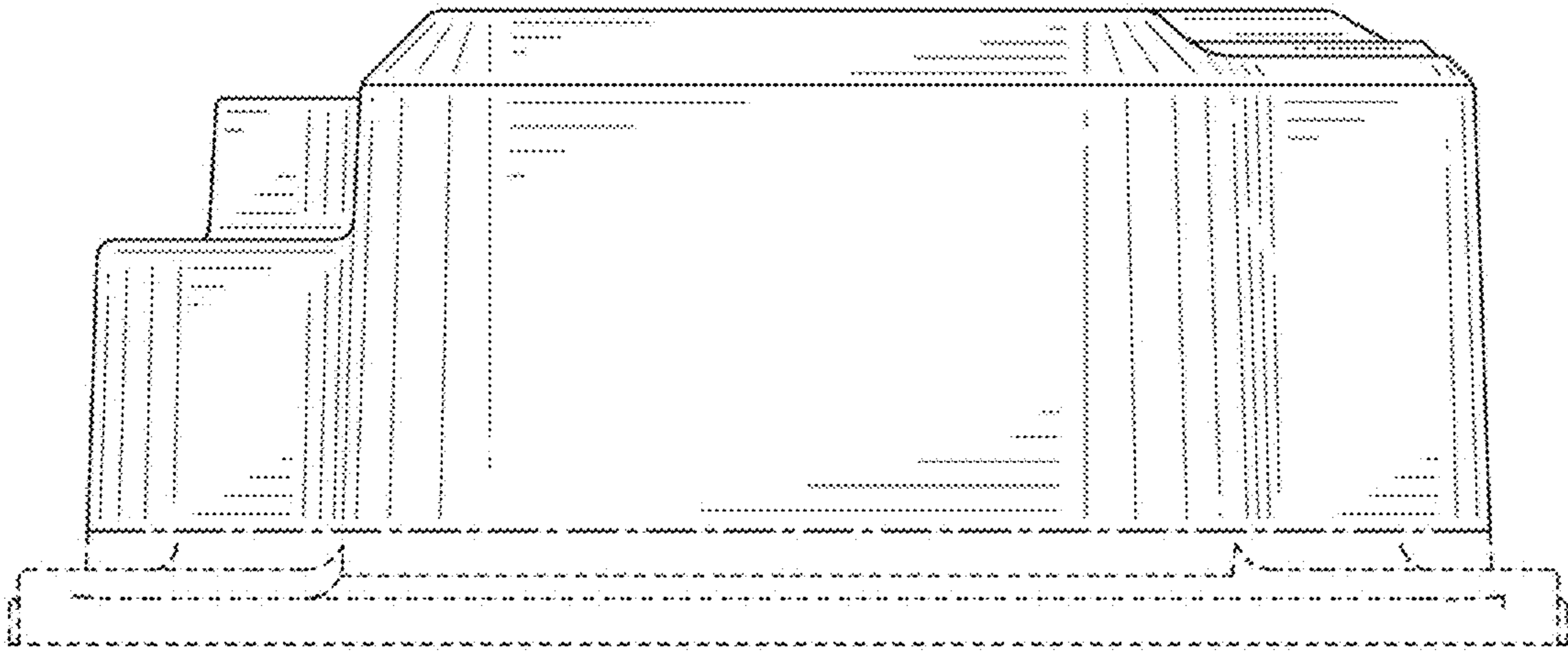

1.6

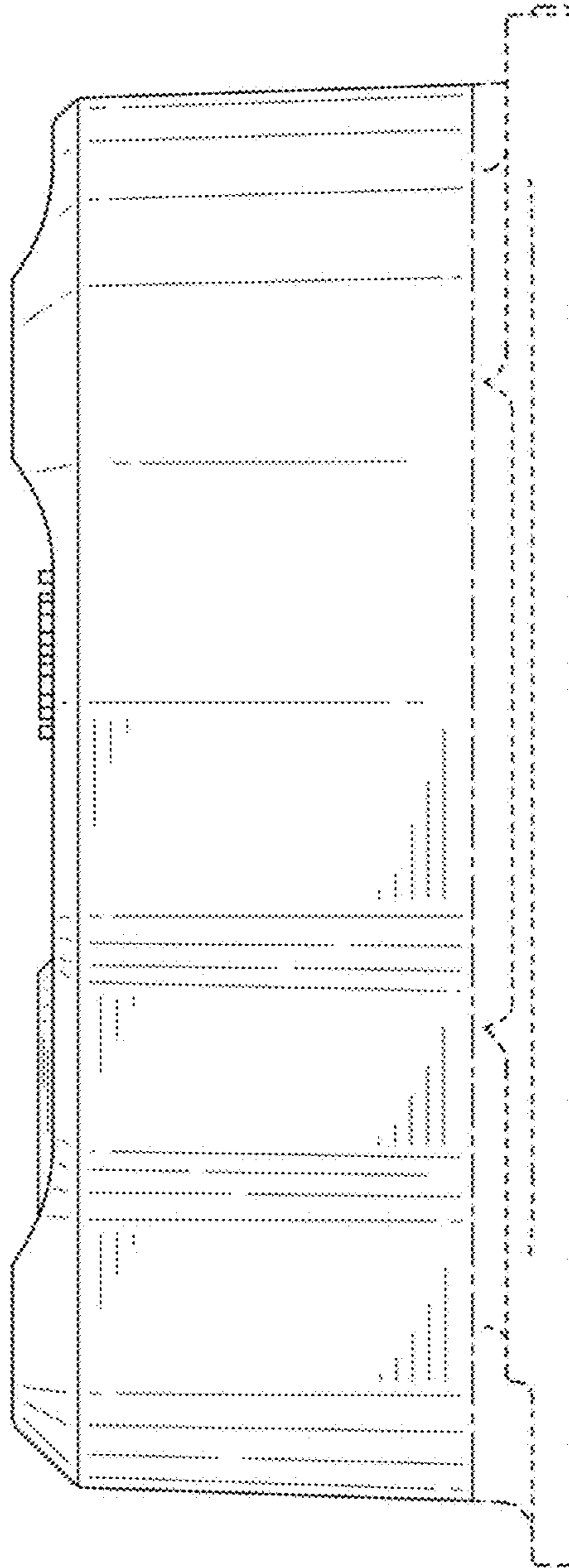

1.7

