



US00D845208S

(12) **United States Design Patent** (10) **Patent No.:** **US D845,208 S**
Fischer (45) **Date of Patent:** **** Apr. 9, 2019**

(54) **BOAT TOP**

(71) Applicant: **NEW BOATS DIRECT, LLC**, Opa Locka, FL (US)

(72) Inventor: **Mark Fischer**, Lighthouse Point, FL (US)

(73) Assignee: **NEW BOATS DIRECT, LLC**, Opa Locka, FL (US)

(**) Term: **15 Years**

(21) Appl. No.: **29/580,489**

(22) Filed: **Oct. 10, 2016**

(51) **LOC (11) Cl.** **12-06**

(52) **U.S. Cl.**
USPC **D12/317**

(58) **Field of Classification Search**
USPC D12/300–318; D21/542–547
CPC B63B 17/00; B63B 17/002; B63B 17/02
See application file for complete search history.

(56) **References Cited**

U.S. PATENT DOCUMENTS

D355,883 S *	2/1995	Simpkins	D12/317
D407,683 S *	4/1999	Linssen	D12/317
D454,108 S *	3/2002	Brown	D12/317
D606,481 S *	12/2009	Stepp	D12/317
8,522,709 B2 *	9/2013	Williams	B63B 17/02 114/253
D697,018 S *	1/2014	Rodriguez	D12/317
D701,820 S *	4/2014	Pierce	D12/317
D718,209 S *	11/2014	Kristinsson	D12/317
9,038,875 B2 *	5/2015	Jesewitz	B63B 25/002 114/343
D737,193 S *	8/2015	Wilson	D12/317

* cited by examiner

Primary Examiner — Cynthia M. Chin

(74) *Attorney, Agent, or Firm* — The Concept Law Group, PA; Scott D. Smiley

(57) **CLAIM**

The ornamental design for a boat top, as shown and described.

DESCRIPTION

FIG. 1 is an elevational front view of a boat top in accordance with the present invention;
 FIG. 2 is an elevational left-side view of the boat top of FIG. 1;
 FIG. 3 is an elevational rear view of the boat top of FIG. 1;
 FIG. 4 is an elevational right-side view of the boat top of FIG. 1;
 FIG. 5 is a top plan view of the boat top of FIG. 1;
 FIG. 6 is a bottom plan view of the boat top of FIG. 1;
 FIG. 7 is an elevational left-side view of the boat top of FIG. 1 attached to a boat;
 FIG. 8 is an elevational right-side view of the boat top of FIG. 1 attached to a boat;
 FIG. 9 is a top plan view of the boat top of FIG. 1 attached to a boat;
 FIG. 10 is an elevational front view of the boat top of FIG. 1 attached to a boat; and,
 FIG. 11 is an elevational rear view of the boat top of FIG. 1 attached to a boat.
 The broken or dashed lines showing a boat and a plurality of boat engines depict environment only and form no part of the claimed design.

1 Claim, 11 Drawing Sheets

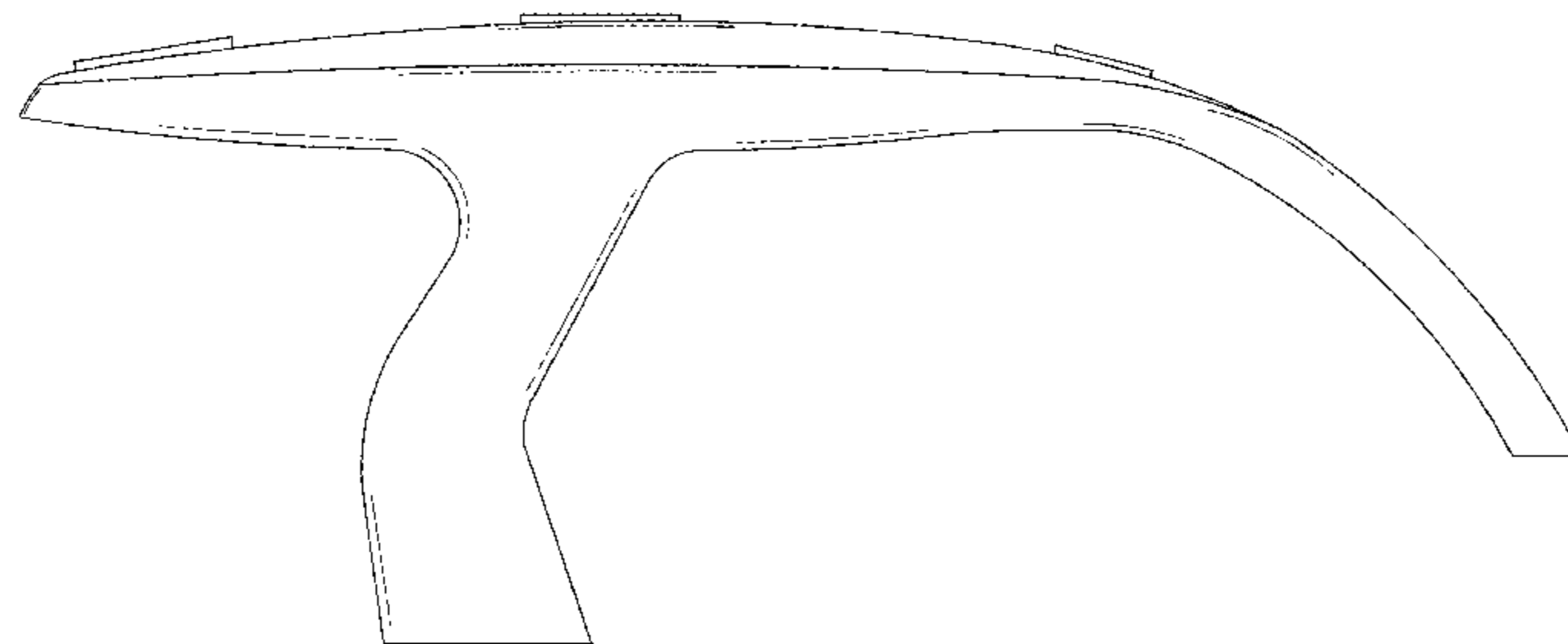

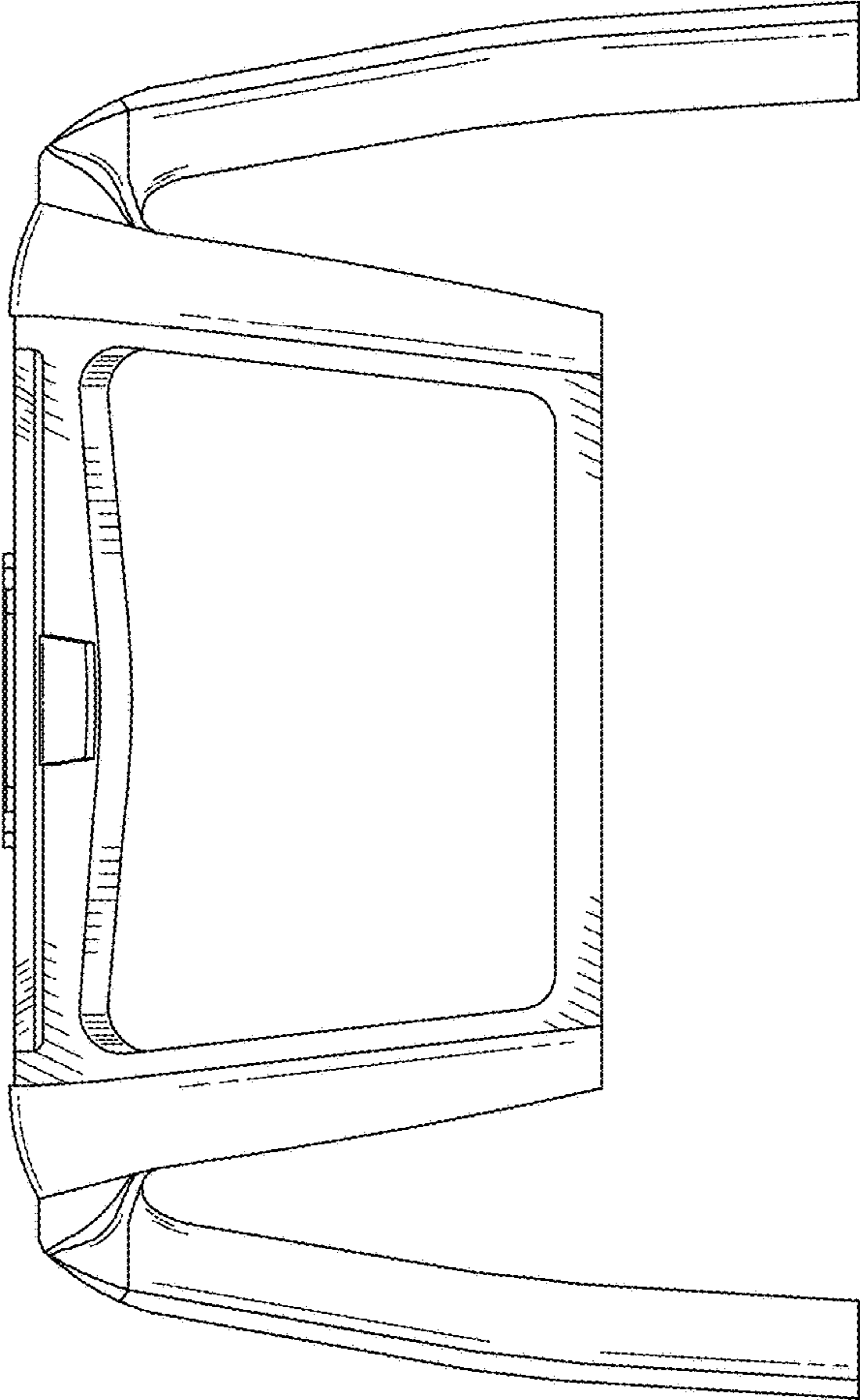

Fig. 1

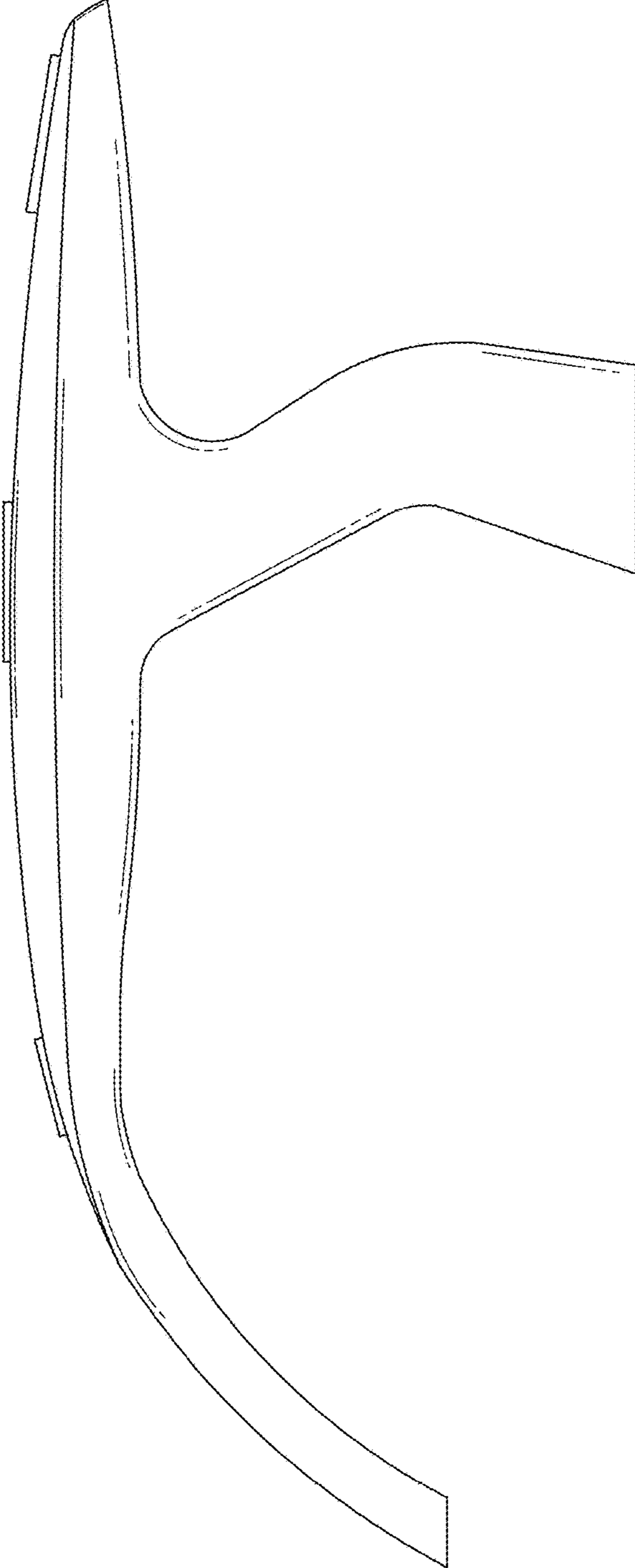

Fig. 2

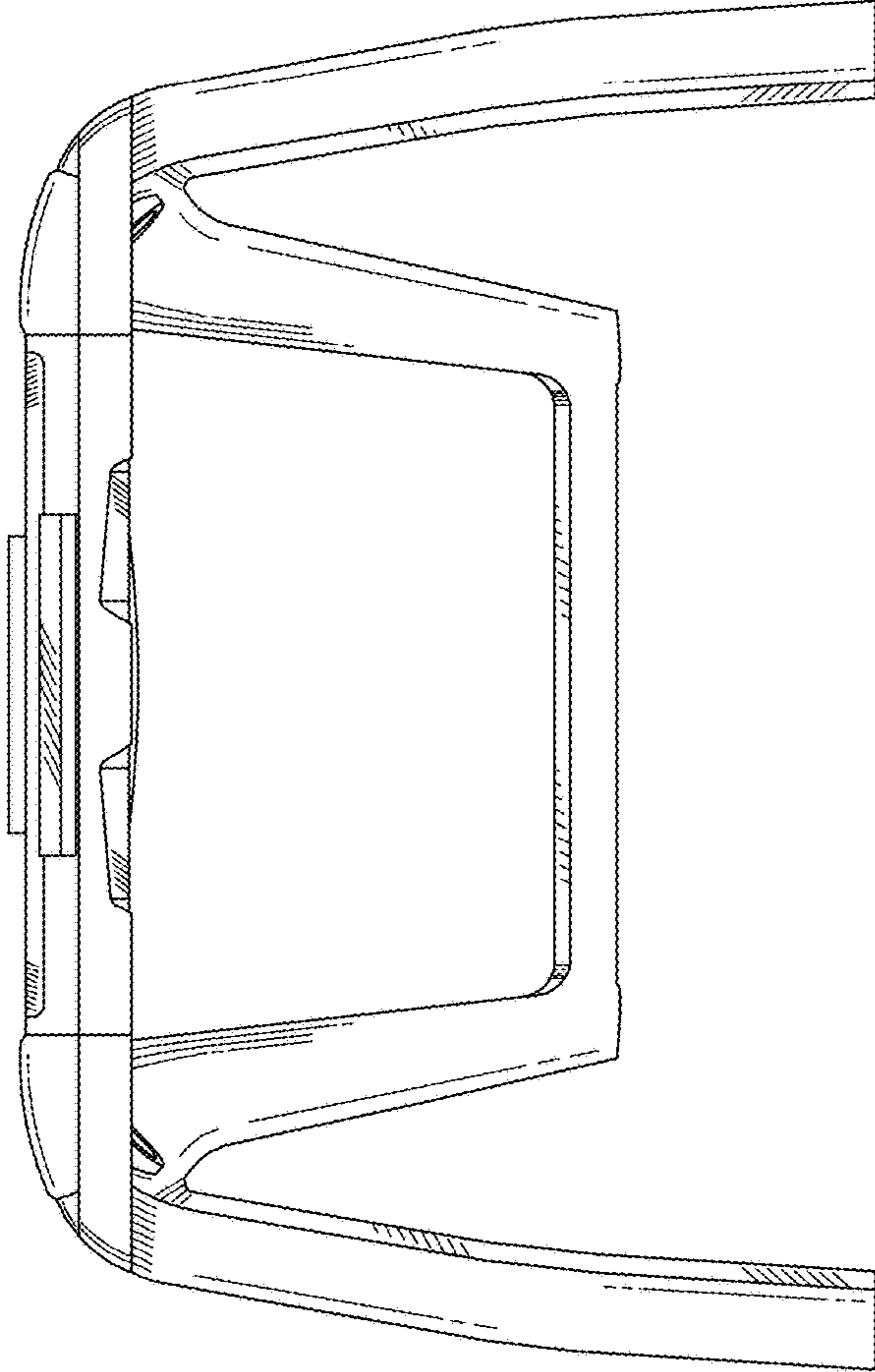

Fig. 3

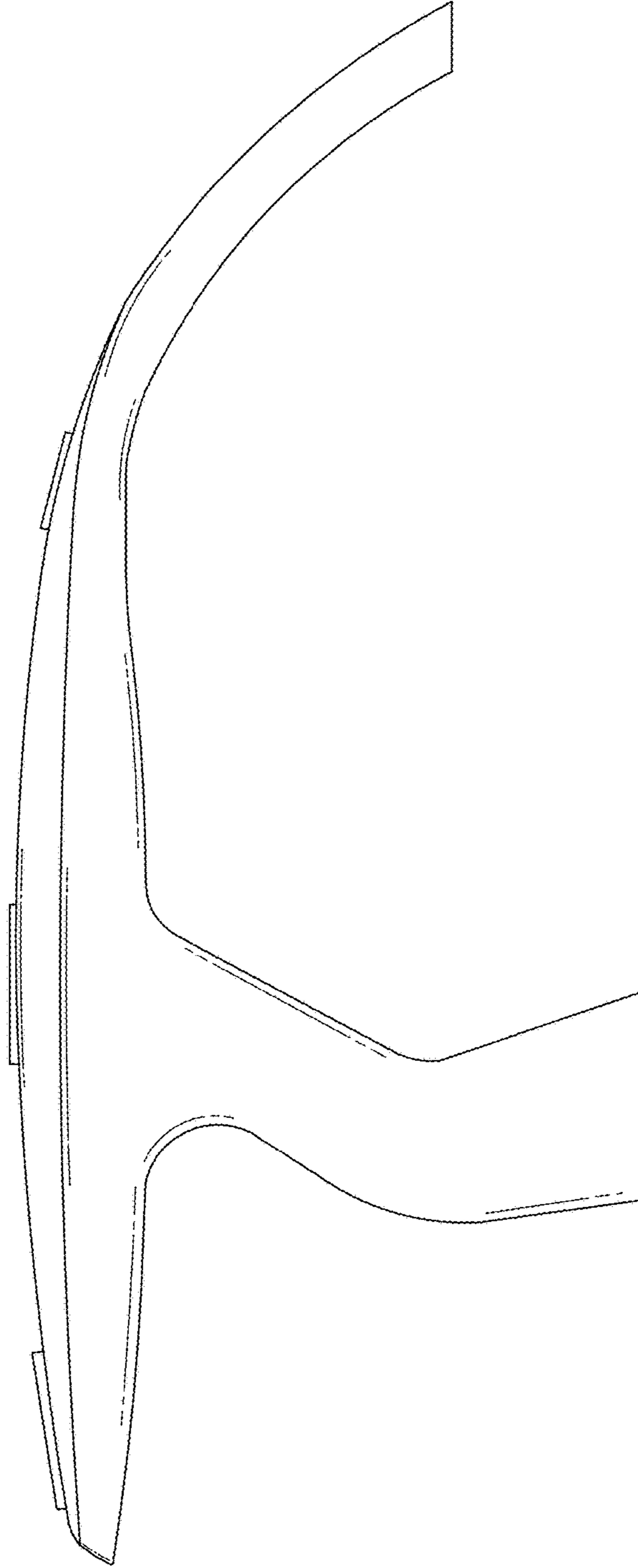

Fig. 4

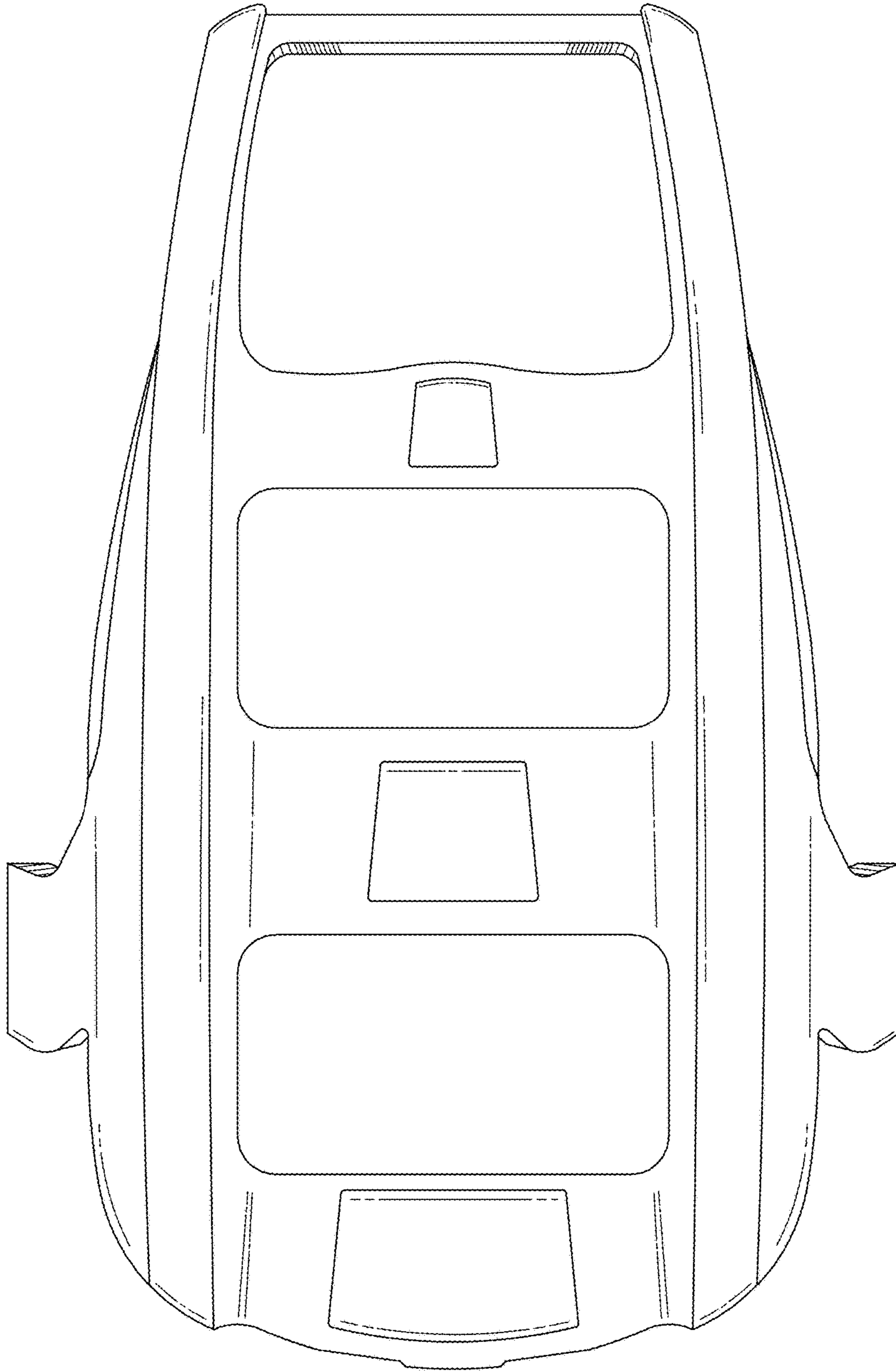

Fig. 5

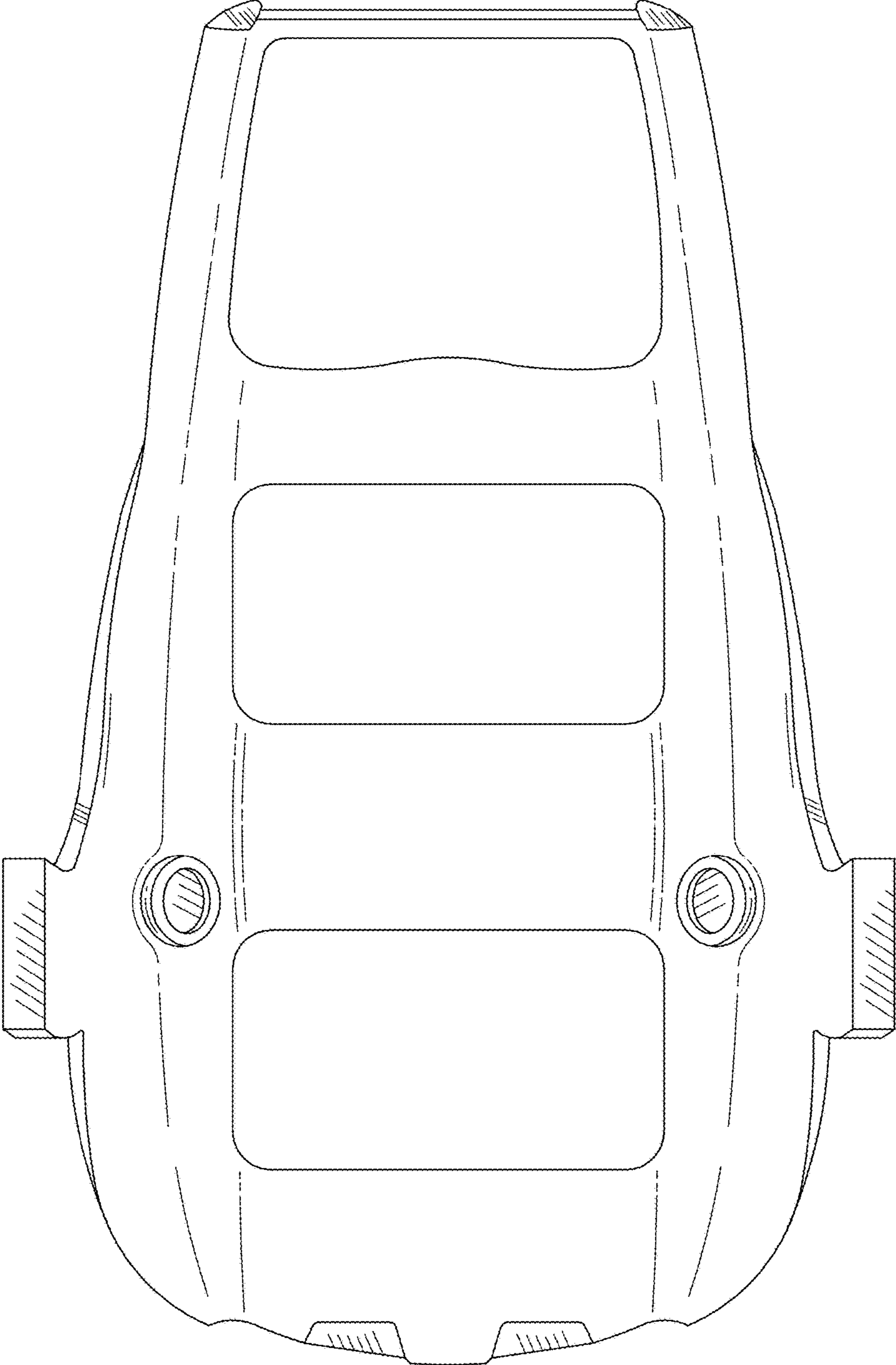

Fig. 6

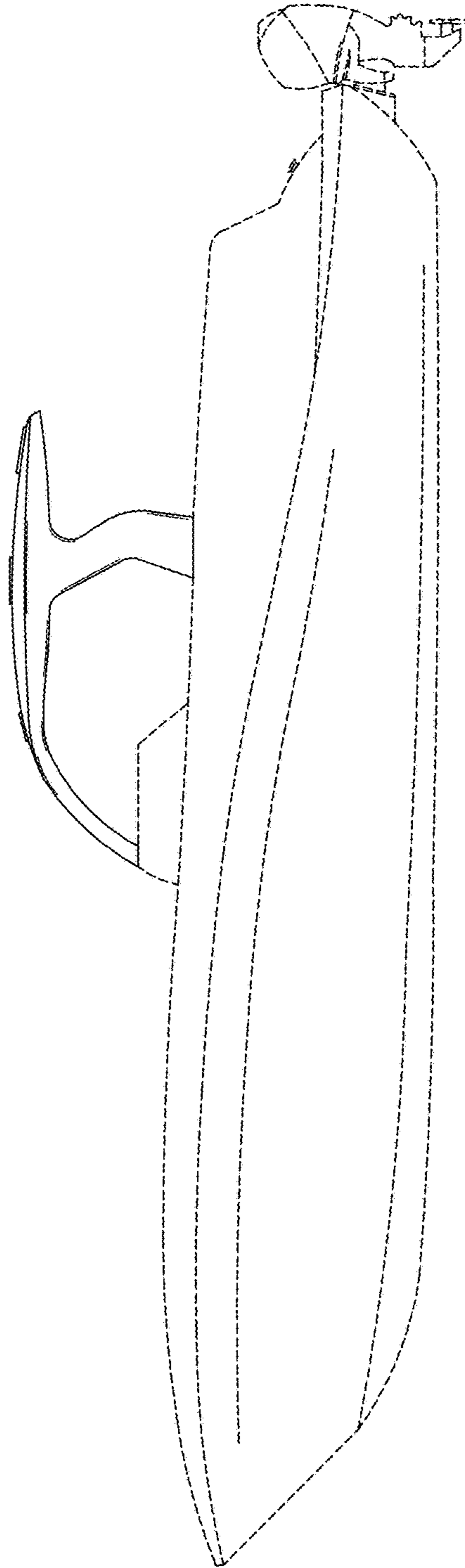

Fig. 7

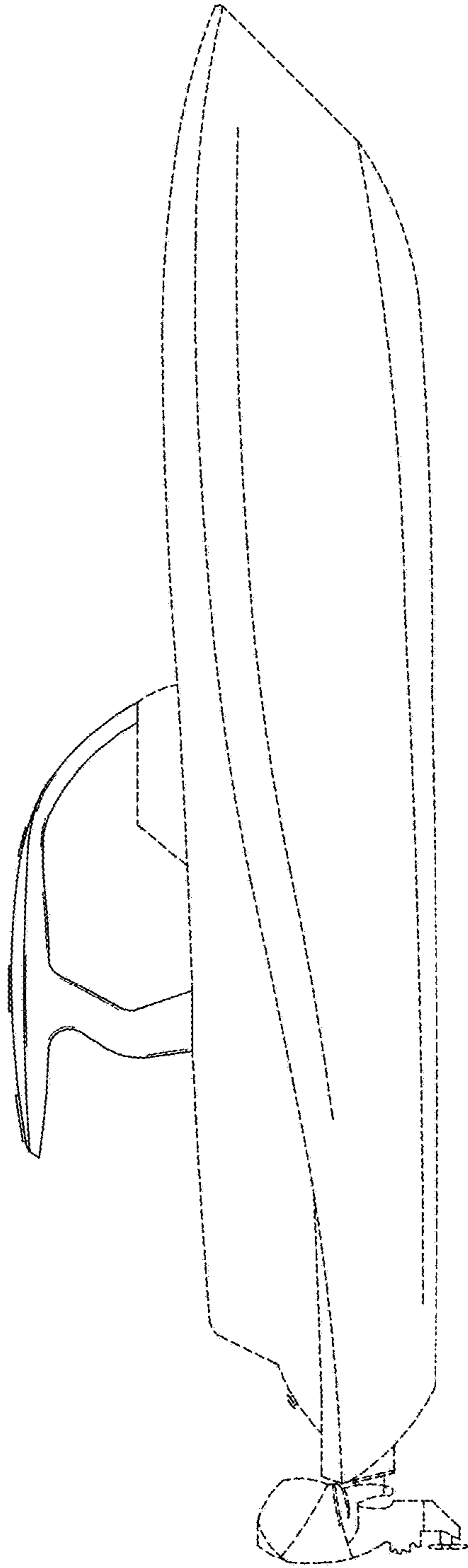

Fig. 8

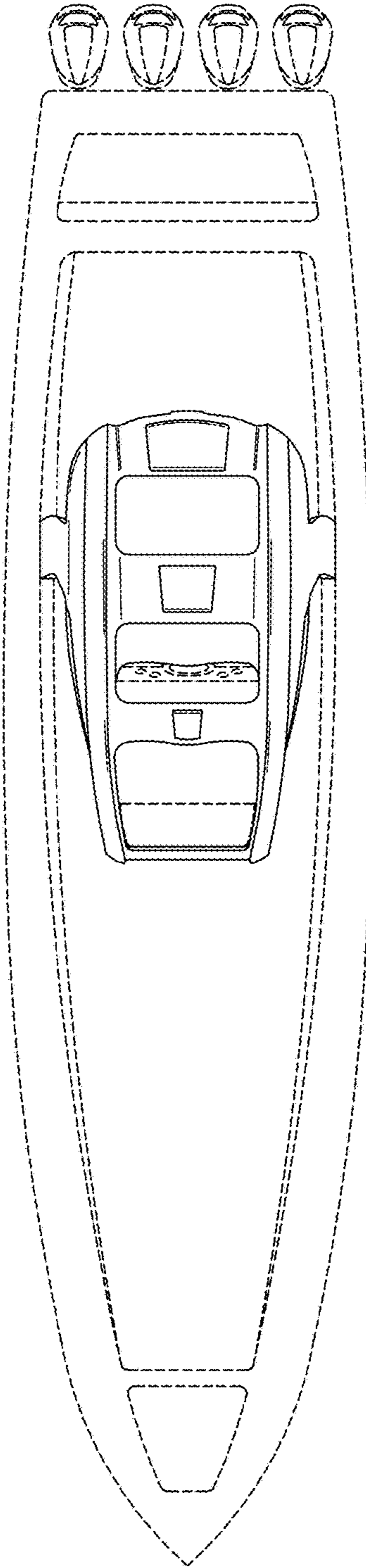

Fig. 9

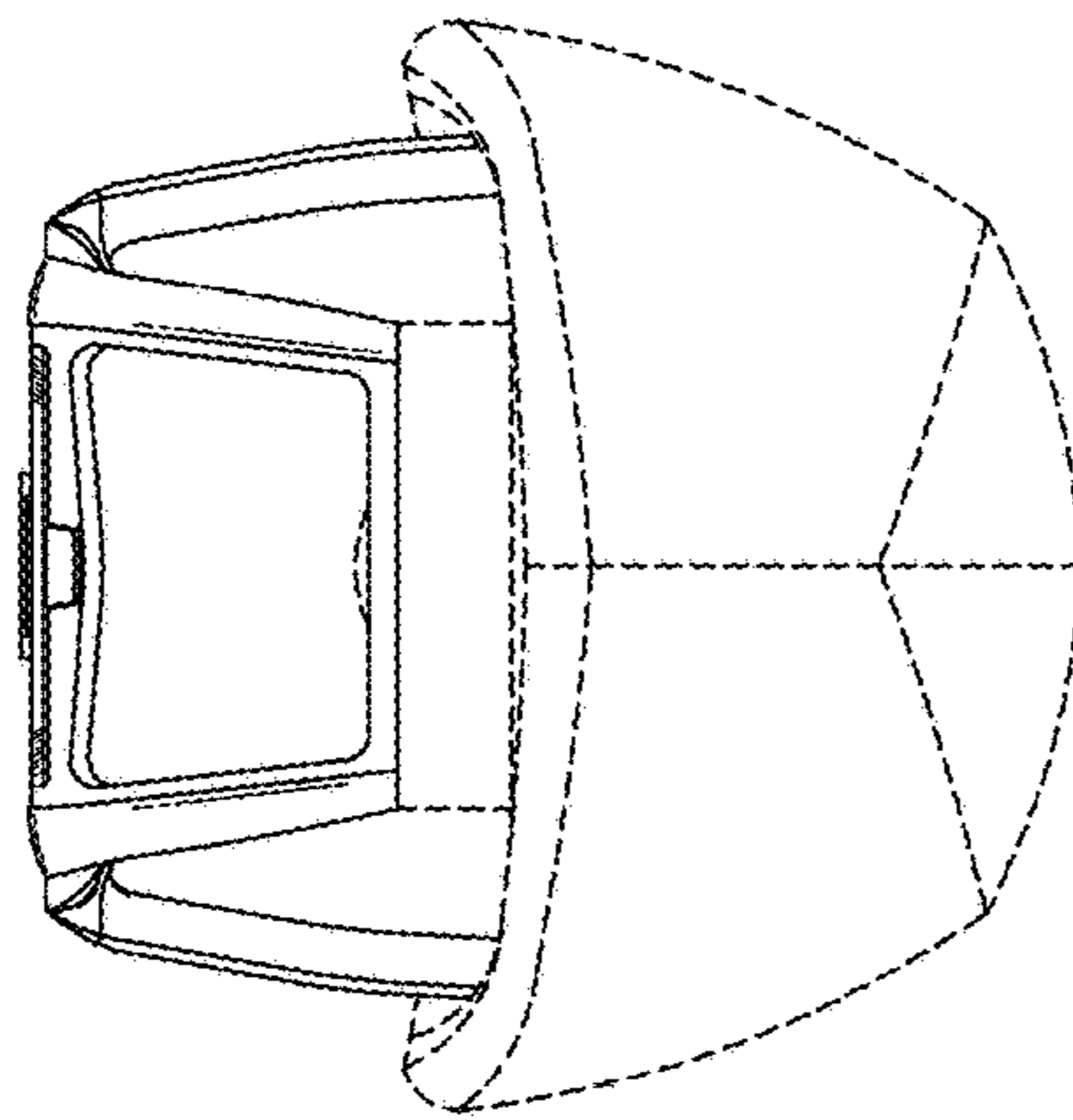

Fig. 10

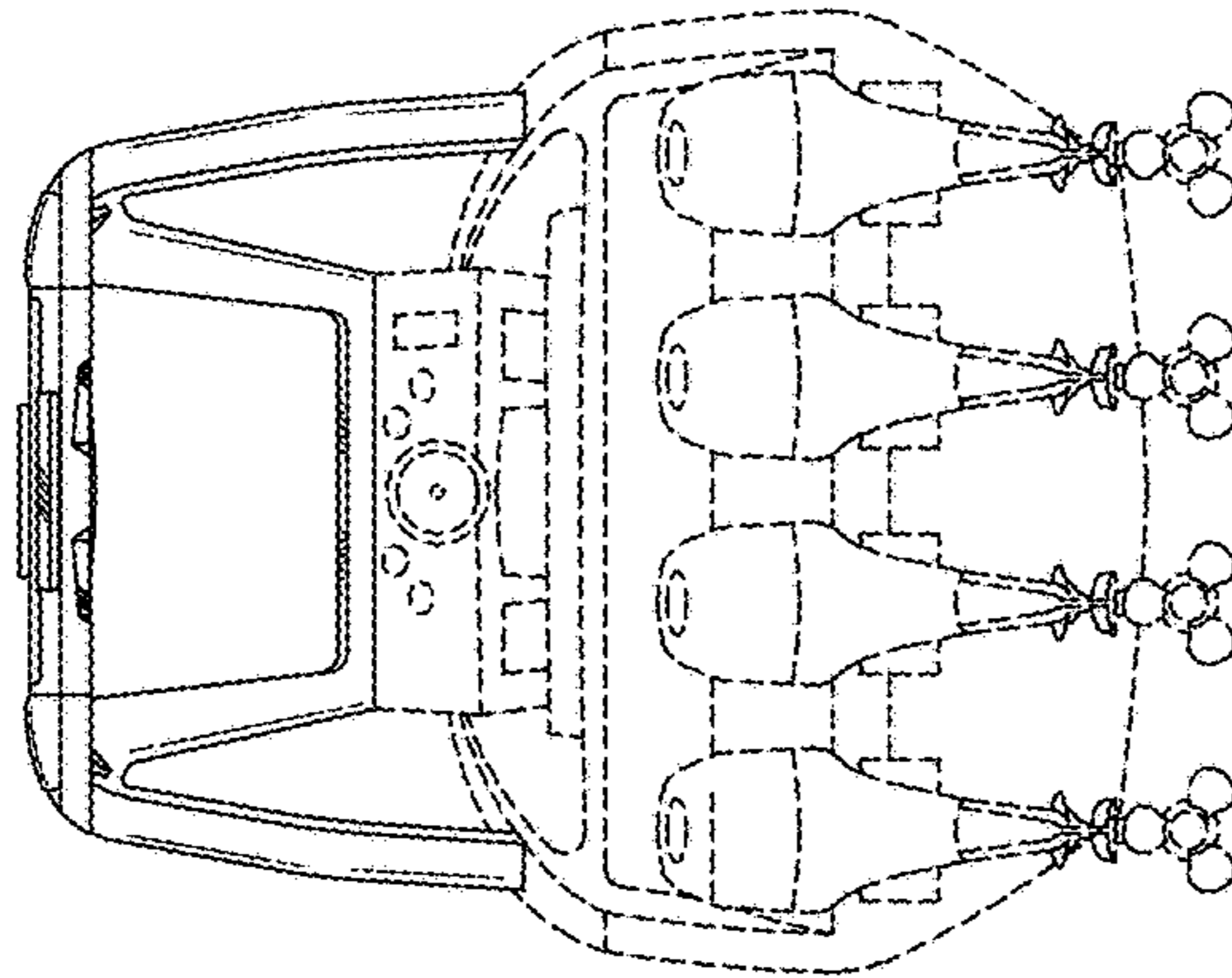

Fig. 11