



US00D845200S

(12) **United States Design Patent** (10) **Patent No.:** **US D845,200 S**
Tomasson et al. (45) **Date of Patent:** **** Apr. 9, 2019**

(54) **CAR SEAT**

B60N 2002/022; A47D 13/02; A47D 13/083; A47D 1/00; A47D 1/002; A47D 1/004; A47D 1/008; A47D 1/04

(71) Applicant: **Nio Nextev Limited**, Hong Kong (HK)

See application file for complete search history.

(72) Inventors: **Kris Tomasson**, Hong Kong (HK);
Jochen Paesen, Hong Kong (HK);
Ryuichiro Goto, Hong Kong (HK);
Phil Gilman, Hong Kong (HK)

(56) **References Cited**

U.S. PATENT DOCUMENTS

(73) Assignee: **NIO NEXTEV LIMITED**, Hong Kong (HK)

D274,863 S *	7/1984	Lindstrom	D6/333
D315,255 S *	3/1991	Beermann	D6/333
D367,181 S *	2/1996	Peters	D6/333
D378,961 S *	4/1997	Nordstrom	D6/361
D399,353 S *	10/1998	Krass	D6/375
D413,026 S *	8/1999	Reithmeier	D6/333
D624,767 S *	10/2010	Alvarez	D6/716

(**) Term: **15 Years**

* cited by examiner

(21) Appl. No.: **29/616,084**

(22) Filed: **Sep. 1, 2017**

Primary Examiner — Abraham Bahta

(30) **Foreign Application Priority Data**

(74) *Attorney, Agent, or Firm* — Hogan Lovells US LLP

Apr. 10, 2017 (CN) 2017 3 0115322
Apr. 17, 2017 (CN) 2017 3 0127263

(57) **CLAIM**

(51) **LOC (11) Cl.** **12-08**

The ornamental design for a car seat, as shown and described.

(52) **U.S. Cl.**

USPC **D12/195**; D6/356; D12/416

DESCRIPTION

(58) **Field of Classification Search**

USPC D6/334–336, 338–339, 491, 333, 716,
D6/716.1–716.7; D12/129; D21/412,
D21/419; 280/30–31; 5/94, 98.1, 99.1,
5/101, 105, 655; 297/183.1–183.4,
297/184.13, 184.15, 184.17, 250.1, 256.1,
297/255, 256.15, 256.16, 174 R, 174 CS,
297/170–173, 136, 148, 27, 61, 68;
4/572.1

FIG. 1 is a front view of the car seat of our design;
FIG. 2 is a rear view thereof;
FIG. 3 is a right side view thereof;
FIG. 4 is a left side view thereof;
FIG. 5 is a top view thereof;
FIG. 6 is a bottom view thereof;
FIG. 7 is a front perspective view thereof.
FIG. 8 is a rear perspective view thereof; and,
FIG. 9 is an exploded perspective view thereof.

CPC B60N 2/2821; B60N 2/02; B60N 2/10;
B60N 2/16; B60N 2/22; B60N 2/26;
B60N 2002/0212; B60N 2002/0216;

1 Claim, 9 Drawing Sheets

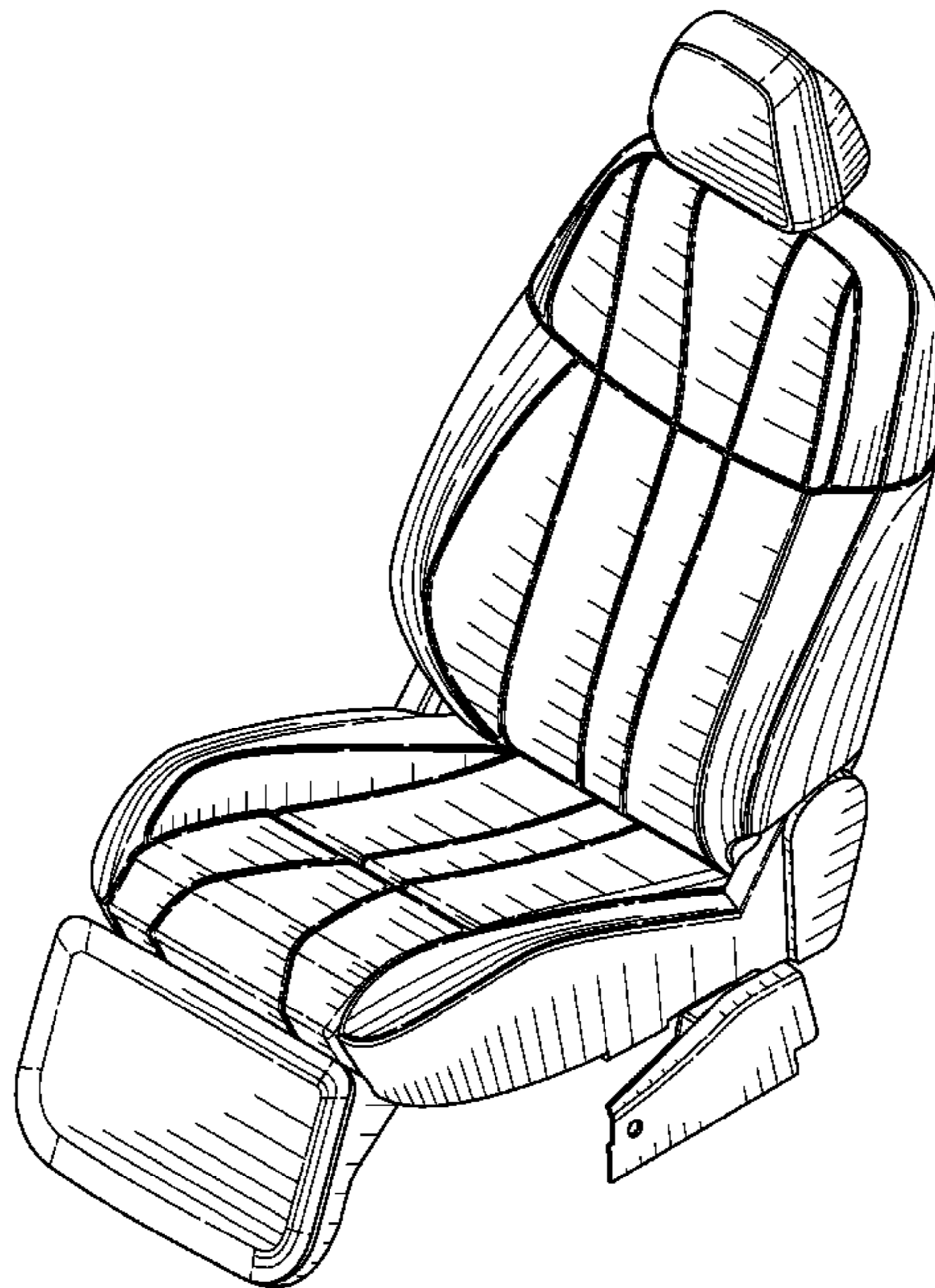

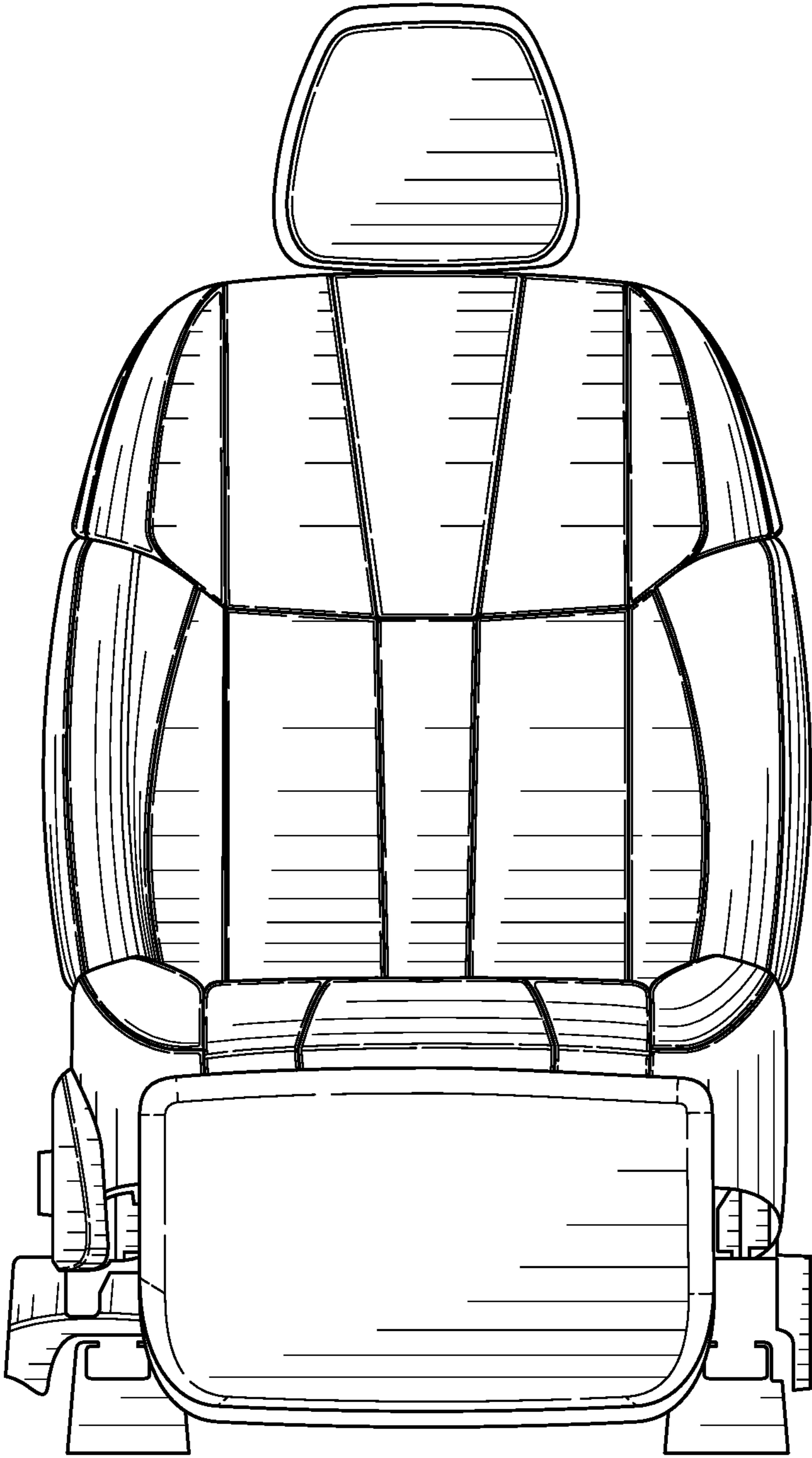

FIG. 1

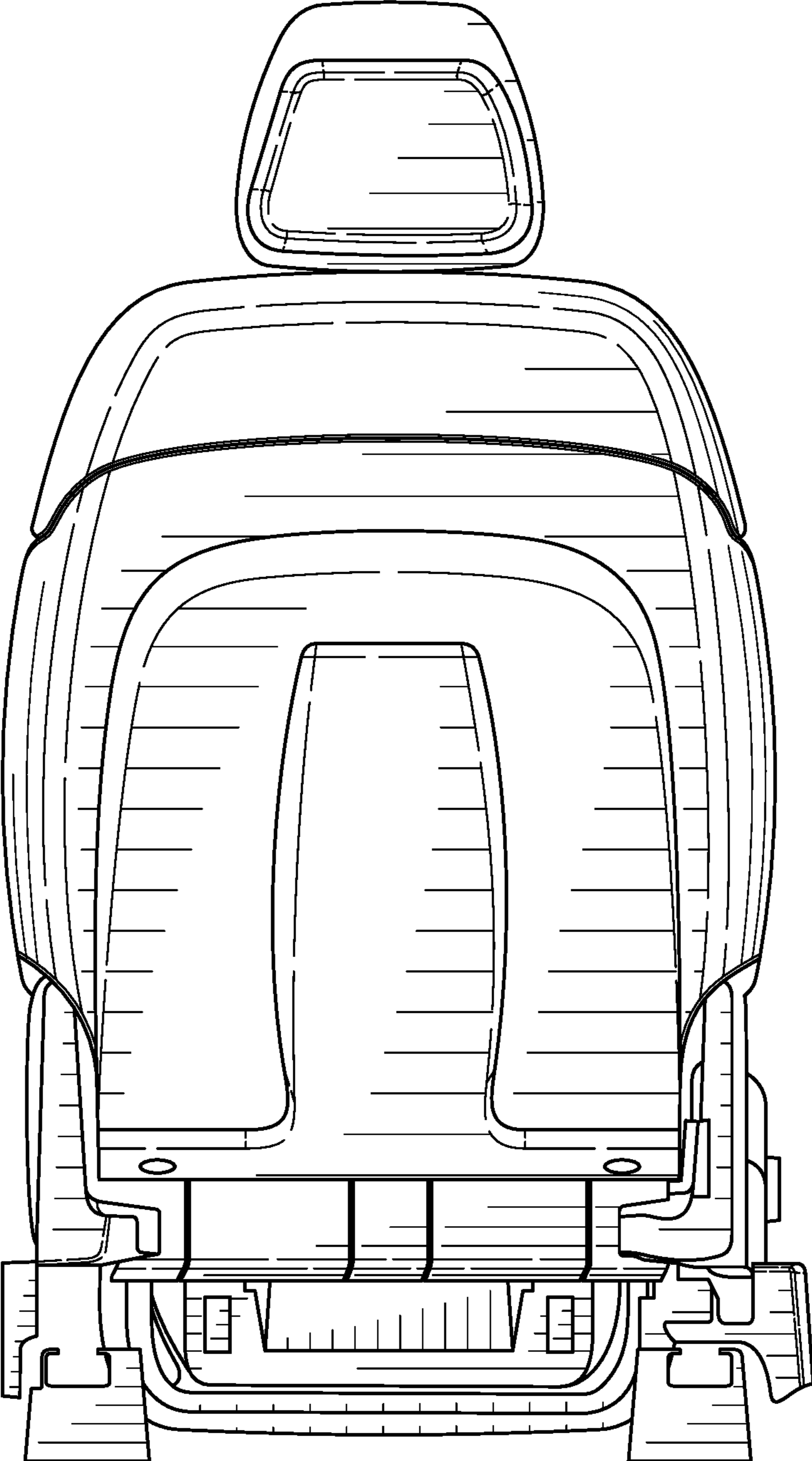

FIG. 2

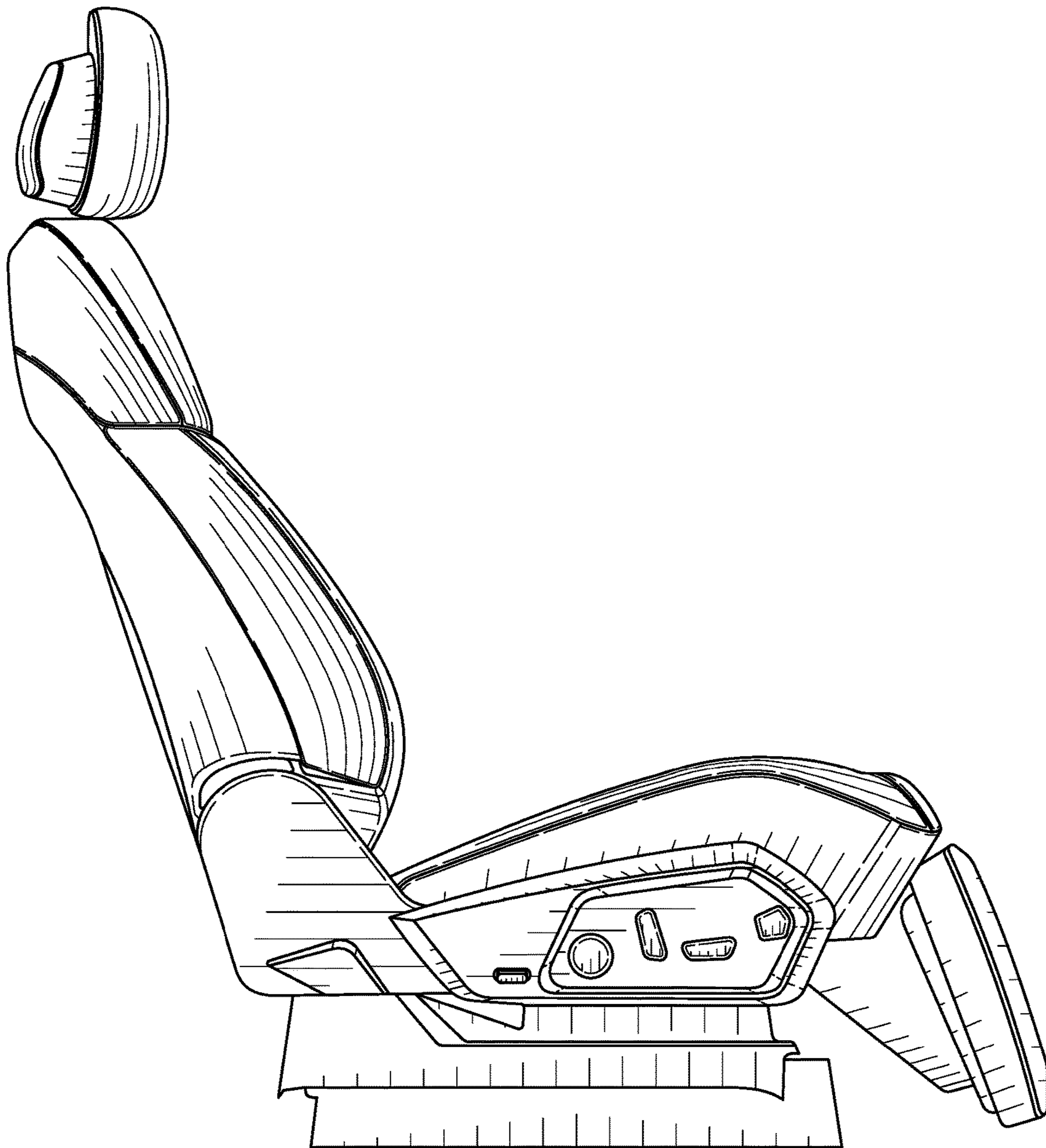

FIG. 3

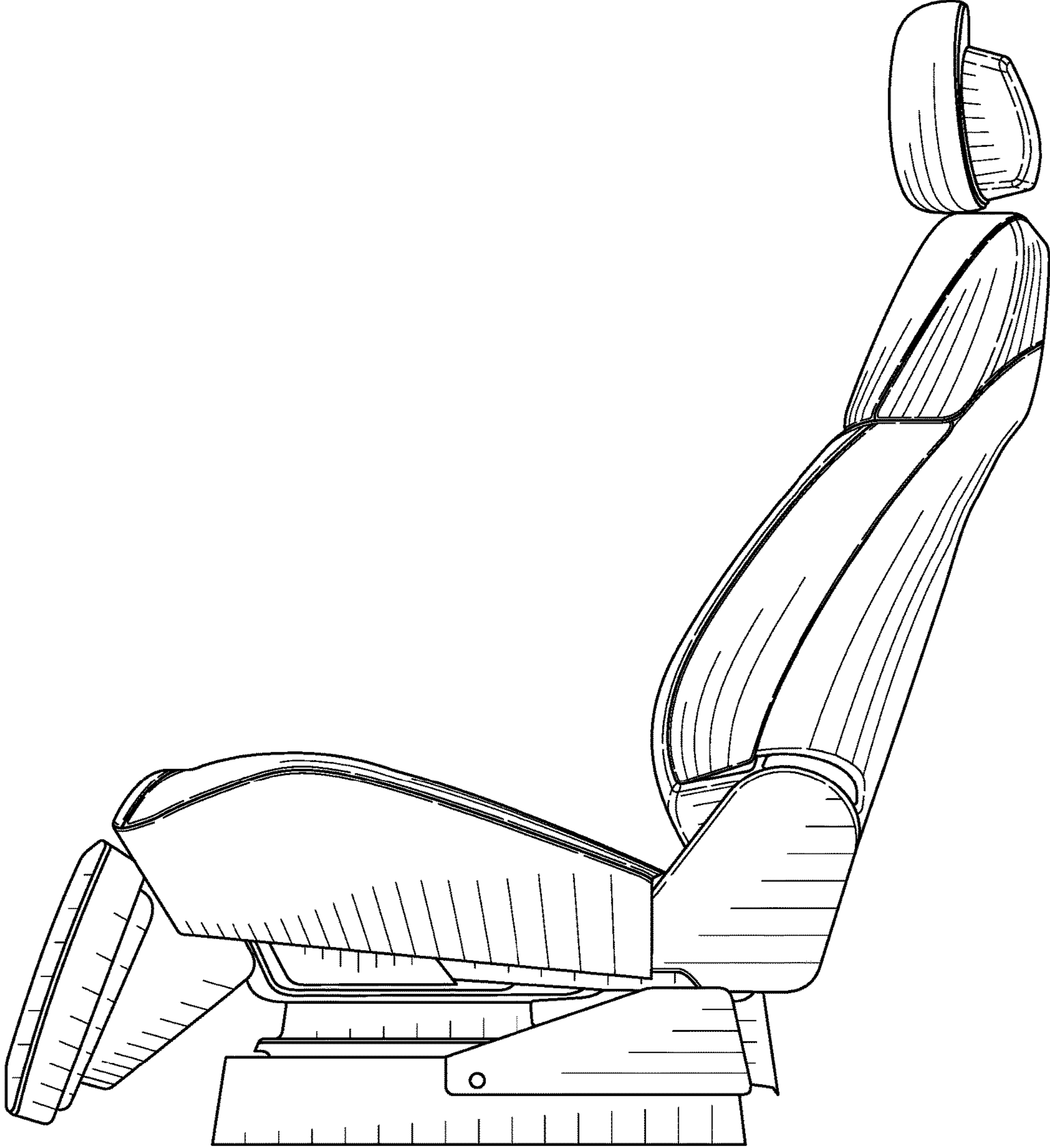

FIG. 4

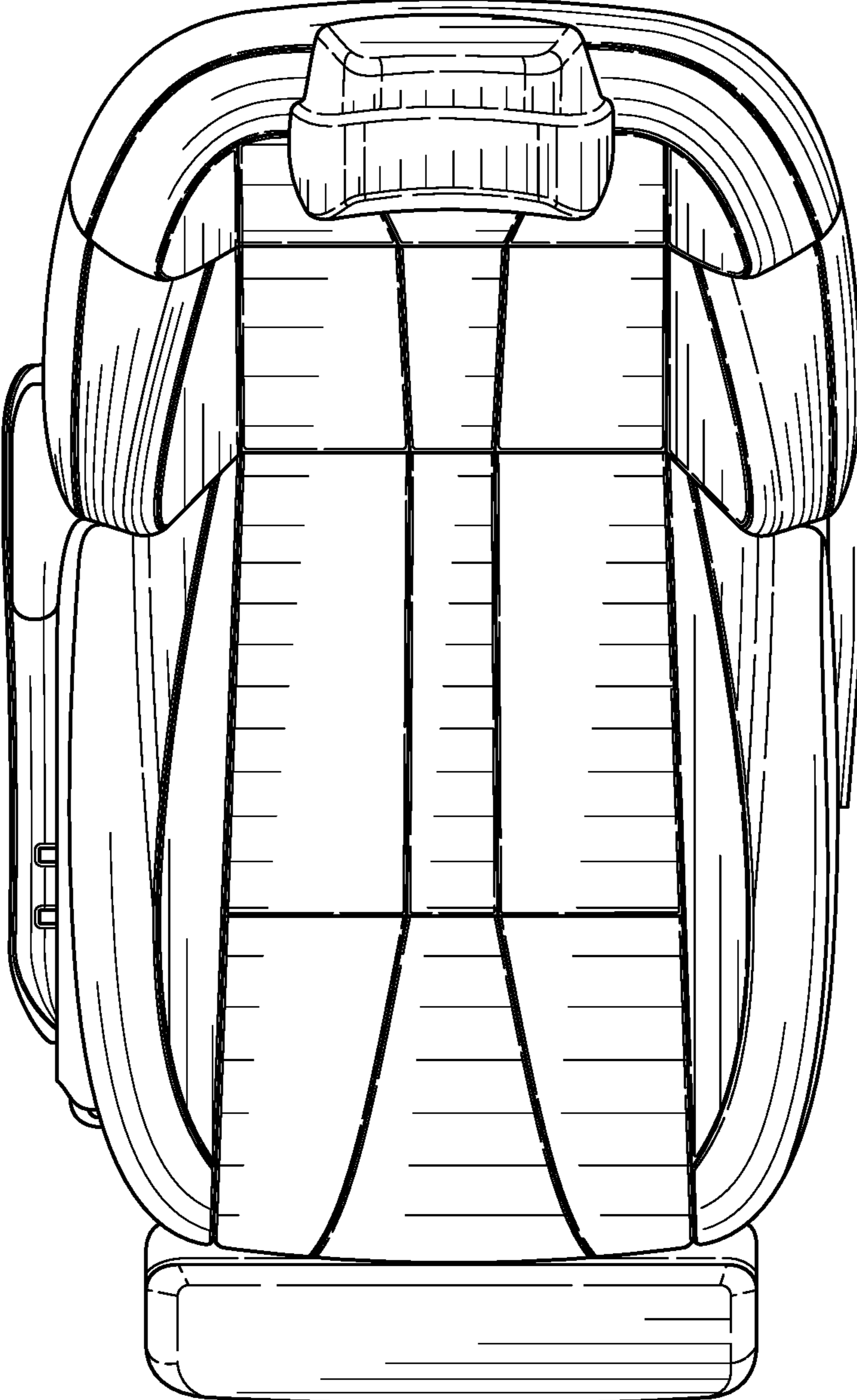

FIG. 5

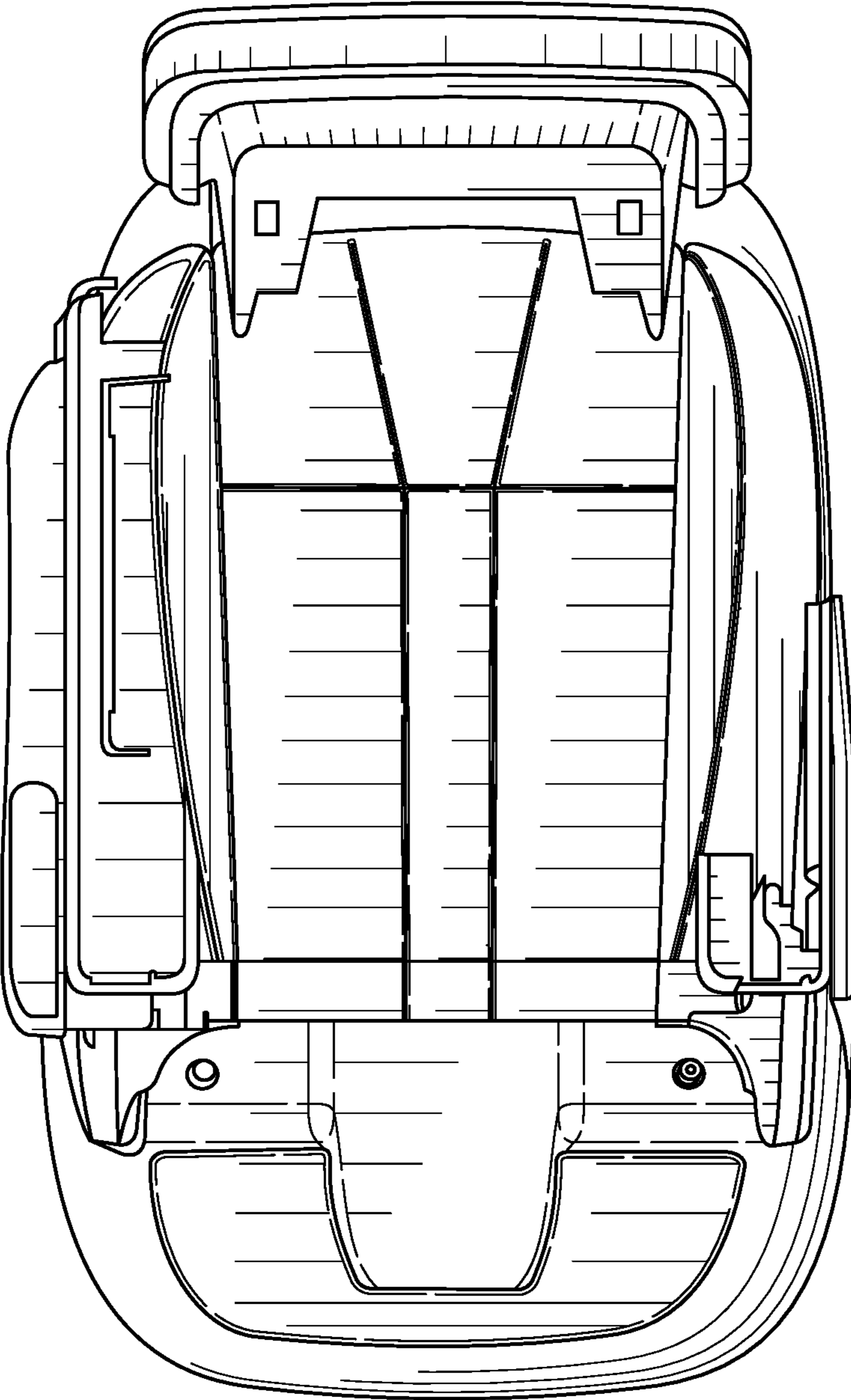

FIG. 6

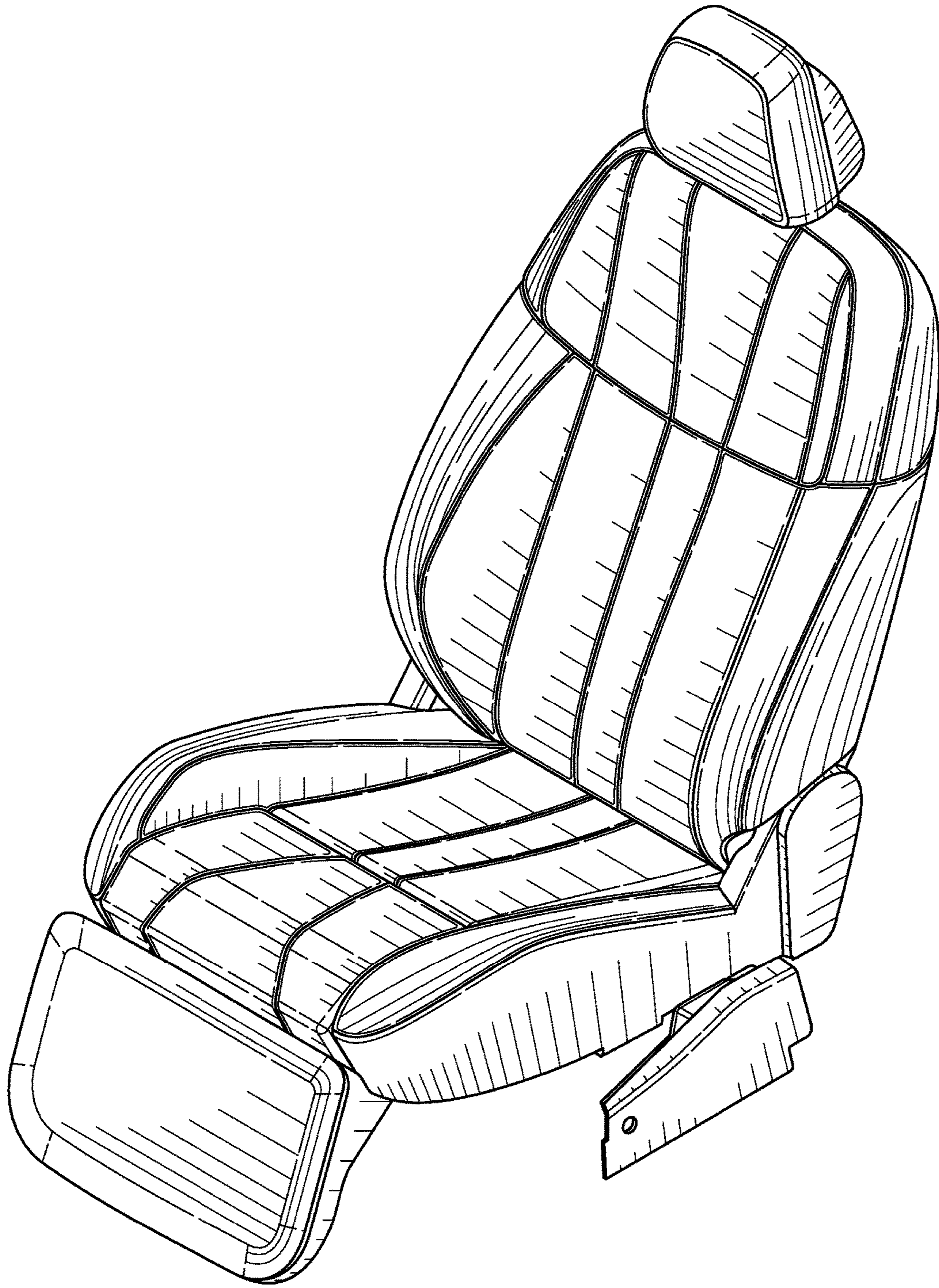

FIG. 7

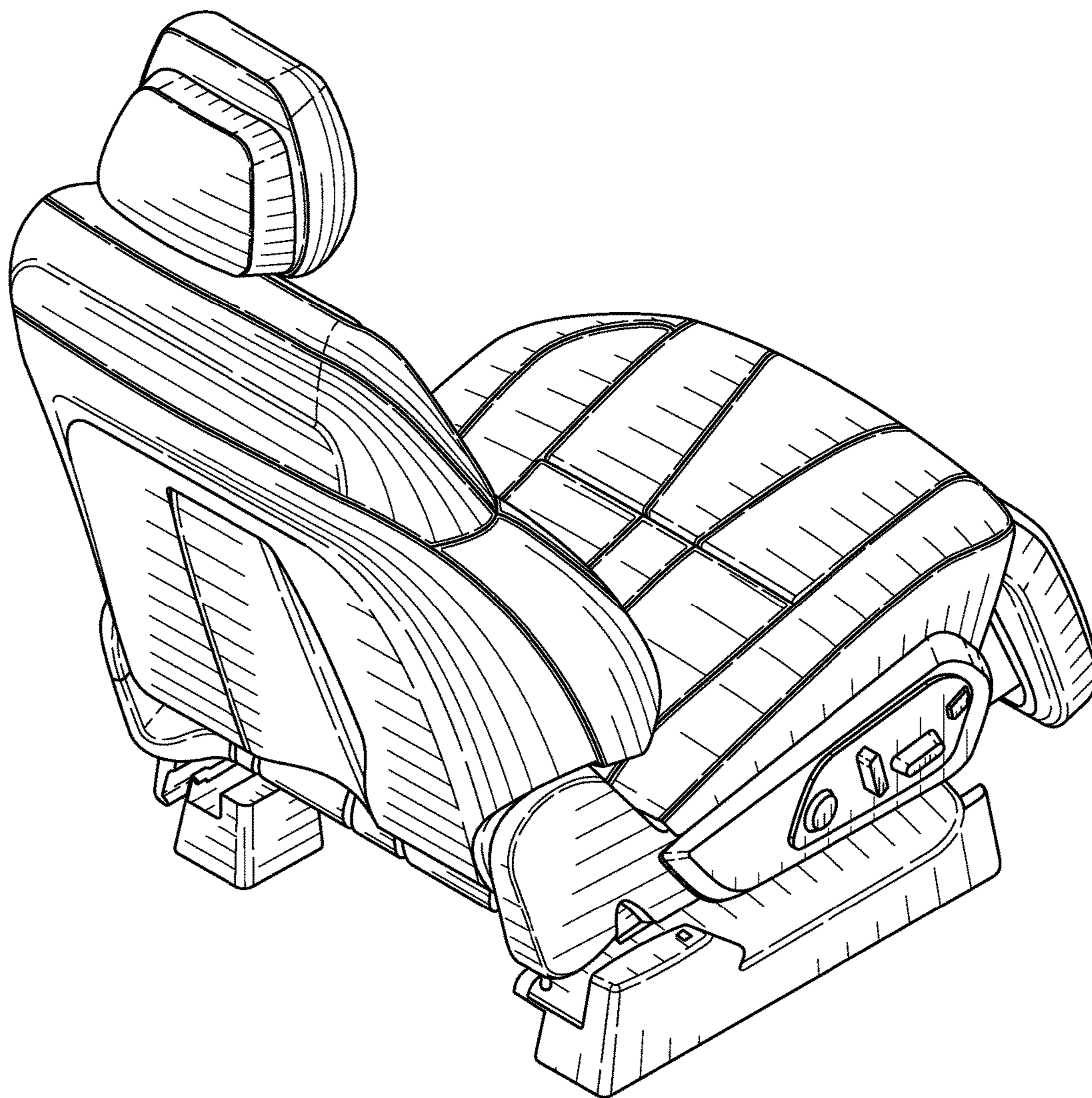

FIG. 8

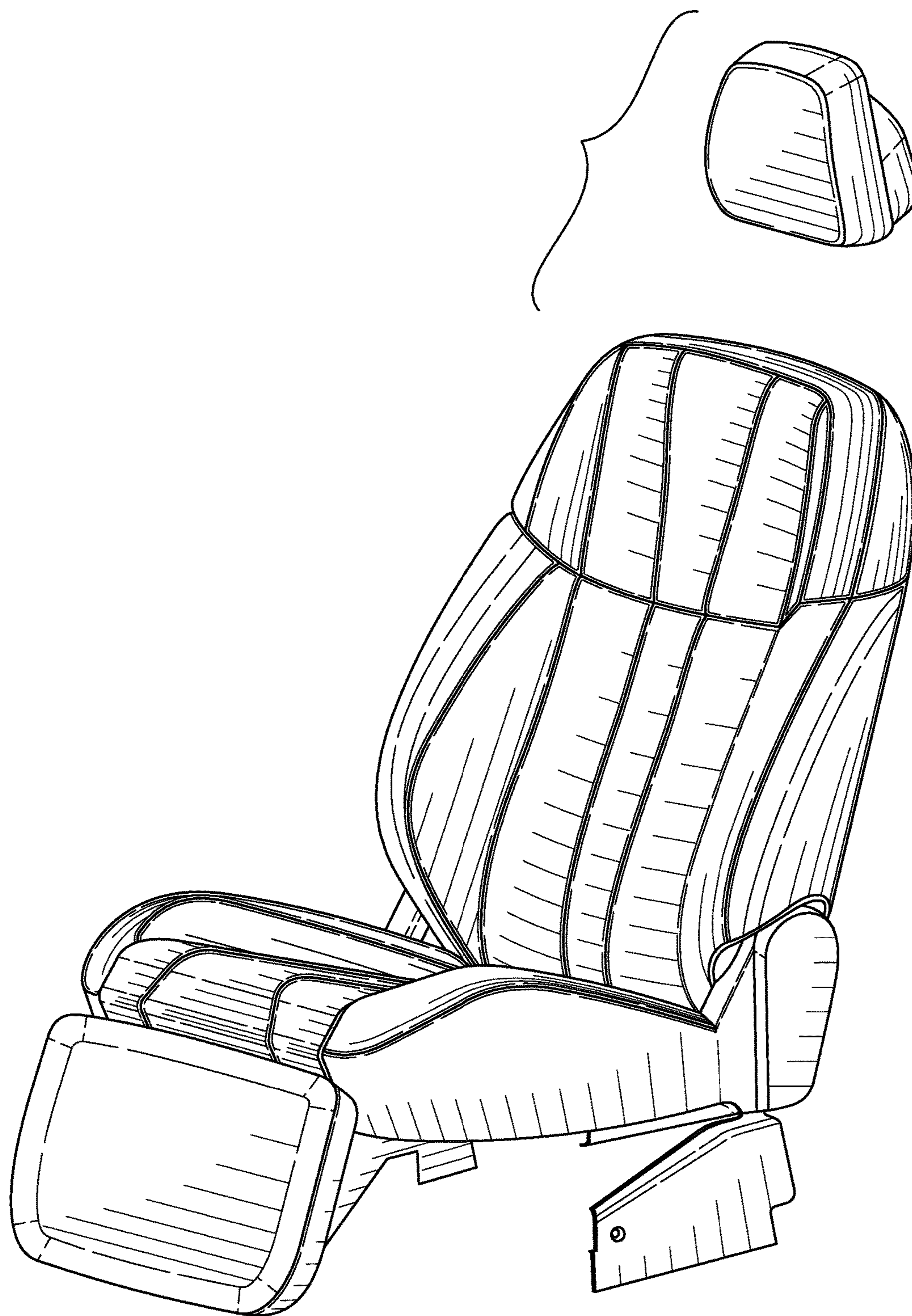

FIG. 9