



US00D845096S

(12) **United States Design Patent** (10) **Patent No.:** **US D845,096 S**  
**Seferi** (45) **Date of Patent:** **\*\* Apr. 9, 2019**

- (54) **GLUE GUN**
- (71) Applicant: **Acme United Corporation**, Fairfield, CT (US)
- (72) Inventor: **Nicholas L. Seferi**, Southbury, CT (US)
- (73) Assignee: **Acme United Corporation**, Fairfield, CT (US)
- (\*\*) Term: **15 Years**
- (21) Appl. No.: **29/594,369**
- (22) Filed: **Feb. 17, 2017**
- (51) **LOC (11) Cl.** ..... **08-05**
- (52) **U.S. Cl.**  
USPC ..... **D8/30**
- (58) **Field of Classification Search**  
USPC ..... D8/14, 14.1, 30, 29.1, 51  
CPC ..... B05C 17/0053; B05C 17/00546; B05C 17/00526; B05C 17/01  
See application file for complete search history.

- D412,432 S 8/1999 Bokros
- D412,650 S 8/1999 Bokros
- D414,663 S 10/1999 Bokros
- 5,984,246 A 11/1999 Gardner
- 5,988,445 A 11/1999 Massena
- 6,056,165 A 5/2000 Speranza
- 6,065,888 A 5/2000 Maayeh
- 6,066,689 A 5/2000 Columbus et al.
- 6,105,824 A 6/2000 Singleton
- D433,301 S 11/2000 Pack
- 6,202,892 B1 3/2001 Lasko
- 6,268,413 B1 7/2001 Columbus et al.
- D455,620 S 4/2002 Lee
- 6,412,667 B1 7/2002 Huang
- 6,457,889 B1 10/2002 Lin
- D469,670 S 2/2003 Belanger
- D474,949 S 5/2003 Schaffeld et al.
- 6,558,059 B1 5/2003 Hillinger et al.
- 6,652,175 B2 11/2003 Chang
- 6,747,251 B1 6/2004 Belanger

(Continued)

*Primary Examiner* — Philip S Hyder  
(74) *Attorney, Agent, or Firm* — Alix, Yale & Ristas, LLP

(57) **CLAIM**

The ornamental design for a glue gun, as shown and described.

**DESCRIPTION**

FIG. 1 is a perspective of a glue gun showing the new design;  
FIG. 2 is a perspective view thereof from a different perspective;  
FIG. 3 is a front view thereof;  
FIG. 4 is a rear view thereof;  
FIG. 5 is a left side view thereof;  
FIG. 6 is a right side view thereof;  
FIG. 7 is a top plan view thereof; and,  
FIG. 8 is a bottom plan view thereof.

**1 Claim, 4 Drawing Sheets**

- (56) **References Cited**  
U.S. PATENT DOCUMENTS
- D297,299 S \* 8/1988 Krause ..... D8/30
- D303,612 S \* 9/1989 Knispel ..... D8/14.1
- D315,283 S 3/1991 De Carolis et al.
- D316,019 S \* 4/1991 Belanger ..... D8/30
- D316,215 S 4/1991 Belanger
- D398,204 S \* 9/1998 Lee ..... D8/14.1
- D399,719 S 10/1998 Mignanelli
- D402,518 S \* 12/1998 Lee ..... D8/30
- D404,622 S \* 1/1999 Singleton ..... D8/29.1
- D406,992 S 3/1999 Cheng
- 5,876,502 A 3/1999 Sugimura et al.
- 5,881,912 A 3/1999 Bokros
- 5,881,923 A 3/1999 Bokros
- 5,881,924 A 3/1999 Bokros
- 5,895,159 A 4/1999 Liou
- 5,901,881 A 5/1999 Wang

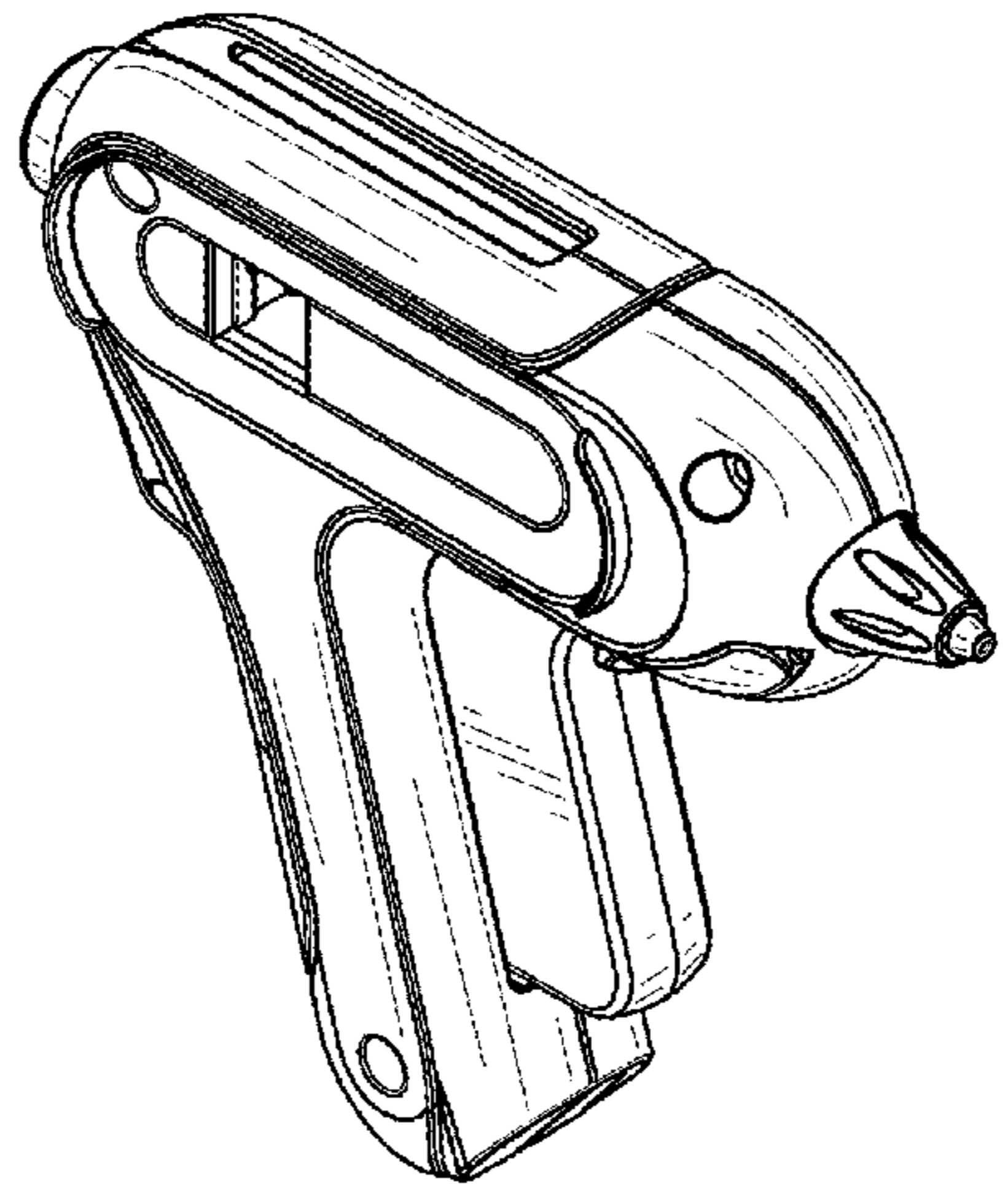

(56)

References Cited

U.S. PATENT DOCUMENTS

6,766,923	B1	7/2004	Huang	
D496,239	S	9/2004	Levine et al.	
6,820,768	B2	11/2004	Belanger	
D505,845	S	6/2005	Lin et al.	
D510,243	S *	10/2005	Lee .....	D8/30
D511,077	S	11/2005	Huang	
D514,406	S	2/2006	Lee	
D514,408	S	2/2006	Melendy et al.	
D517,880	S	3/2006	Melendy et al.	
D535,167	S *	1/2007	Monfeli .....	D8/14.1
D554,960	S	11/2007	Deal et al.	
D557,605	S	12/2007	Reber, II et al.	
D576,458	S	9/2008	Arns	
D590,674	S	4/2009	Belanger	
7,520,408	B1	4/2009	Smith et al.	
7,776,173	B2	6/2010	Schumacher et al.	
D671,385	S	11/2012	Yung-Kuan	
D714,866	S	10/2014	Heipp et al.	
D719,038	S	12/2014	Heipp et al.	
D724,400	S	3/2015	Filian et al.	
D744,305	S	12/2015	Huang	
D748,444	S	2/2016	Huang	
2002/0192005	A1	12/2002	Chang	
2004/0232165	A1	11/2004	Lee	
2006/0196888	A1	9/2006	Agronin et al.	
2008/0197155	A1	8/2008	Liang	
2008/0223511	A1	9/2008	Schumacher et al.	
2011/0056994	A1	3/2011	Yen	
2015/0209820	A1	7/2015	Ono	
2017/0320089	A1 *	11/2017	Seferi .....	B05C 17/00503

\* cited by examiner

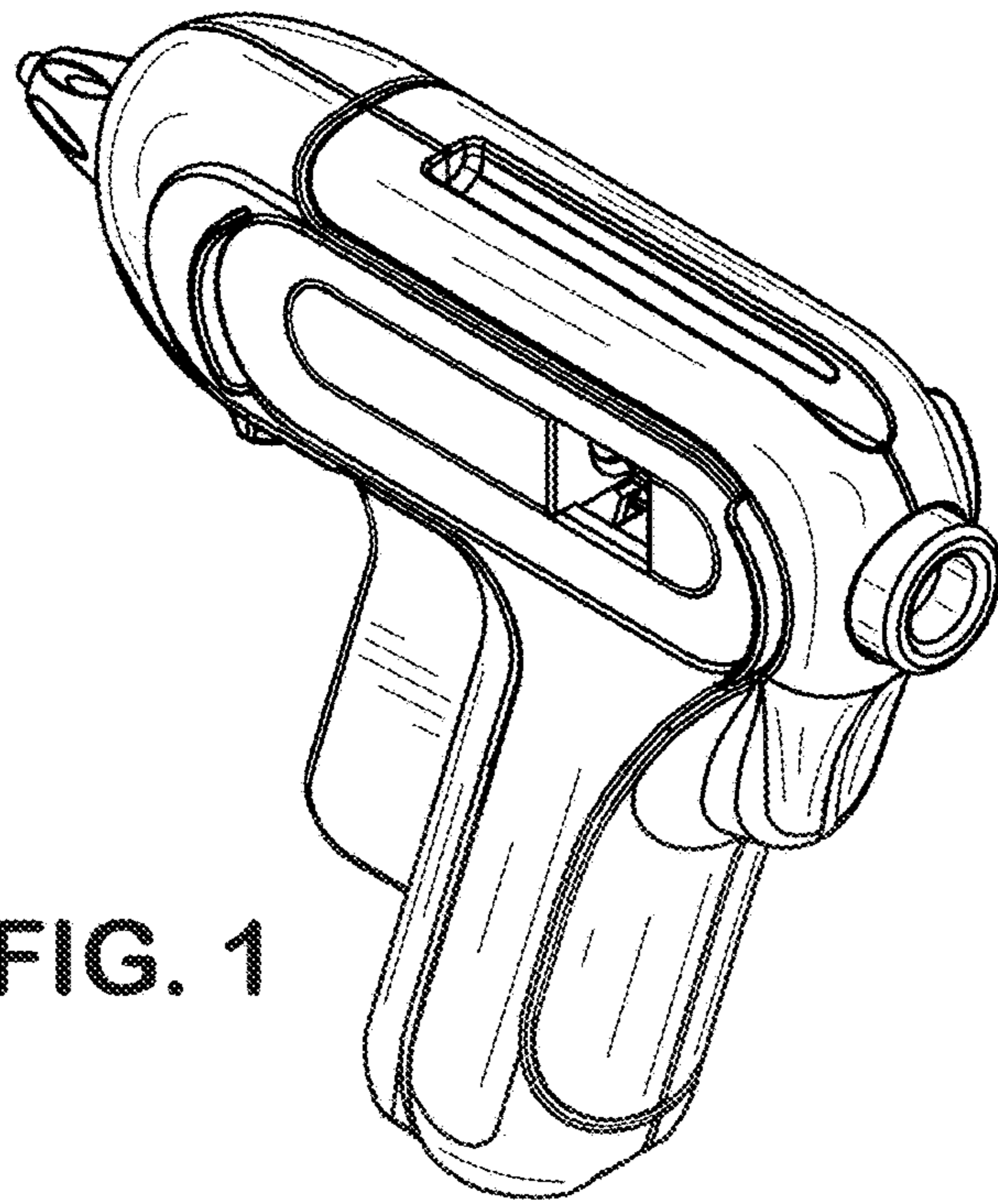

FIG. 1

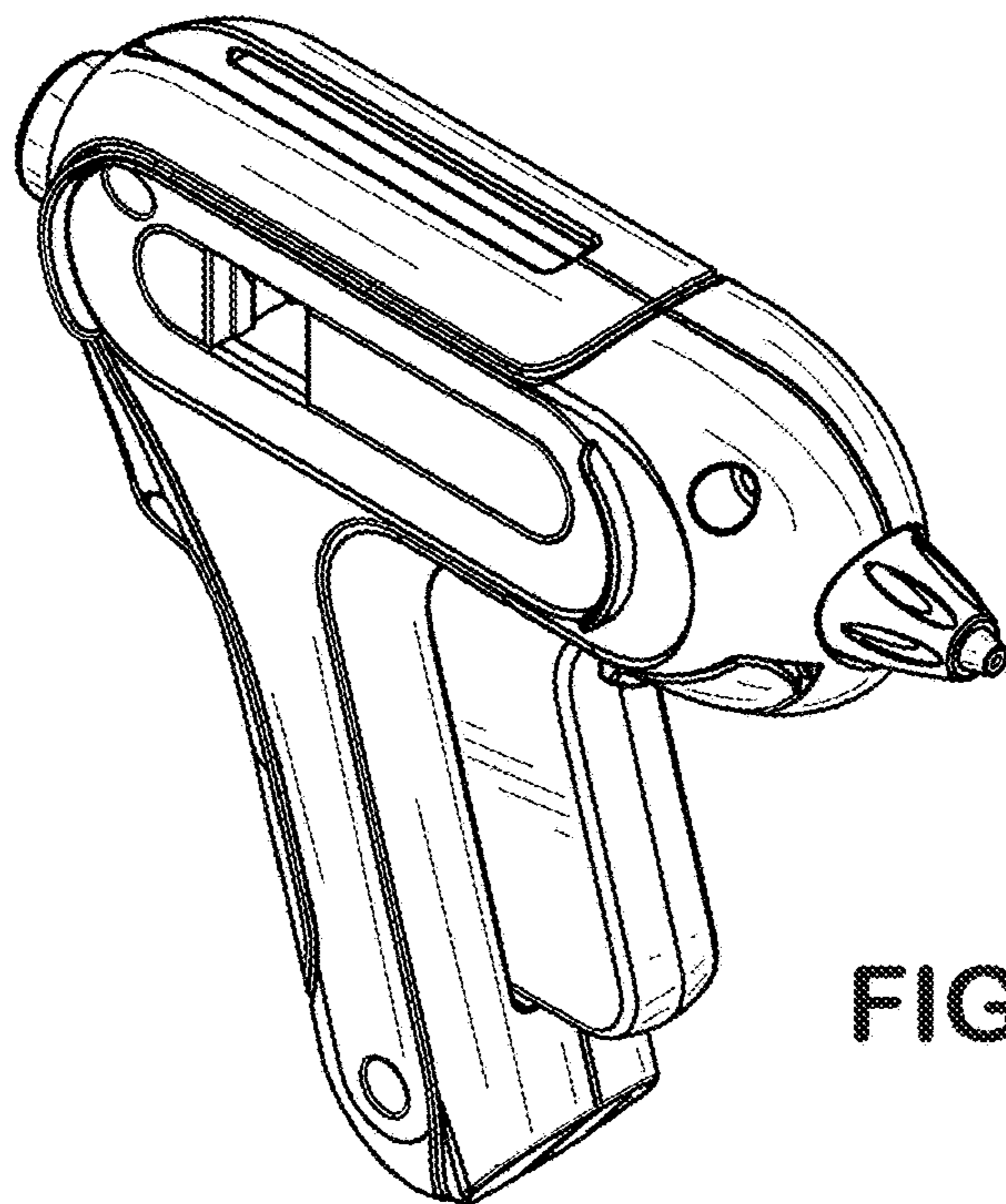

FIG. 2

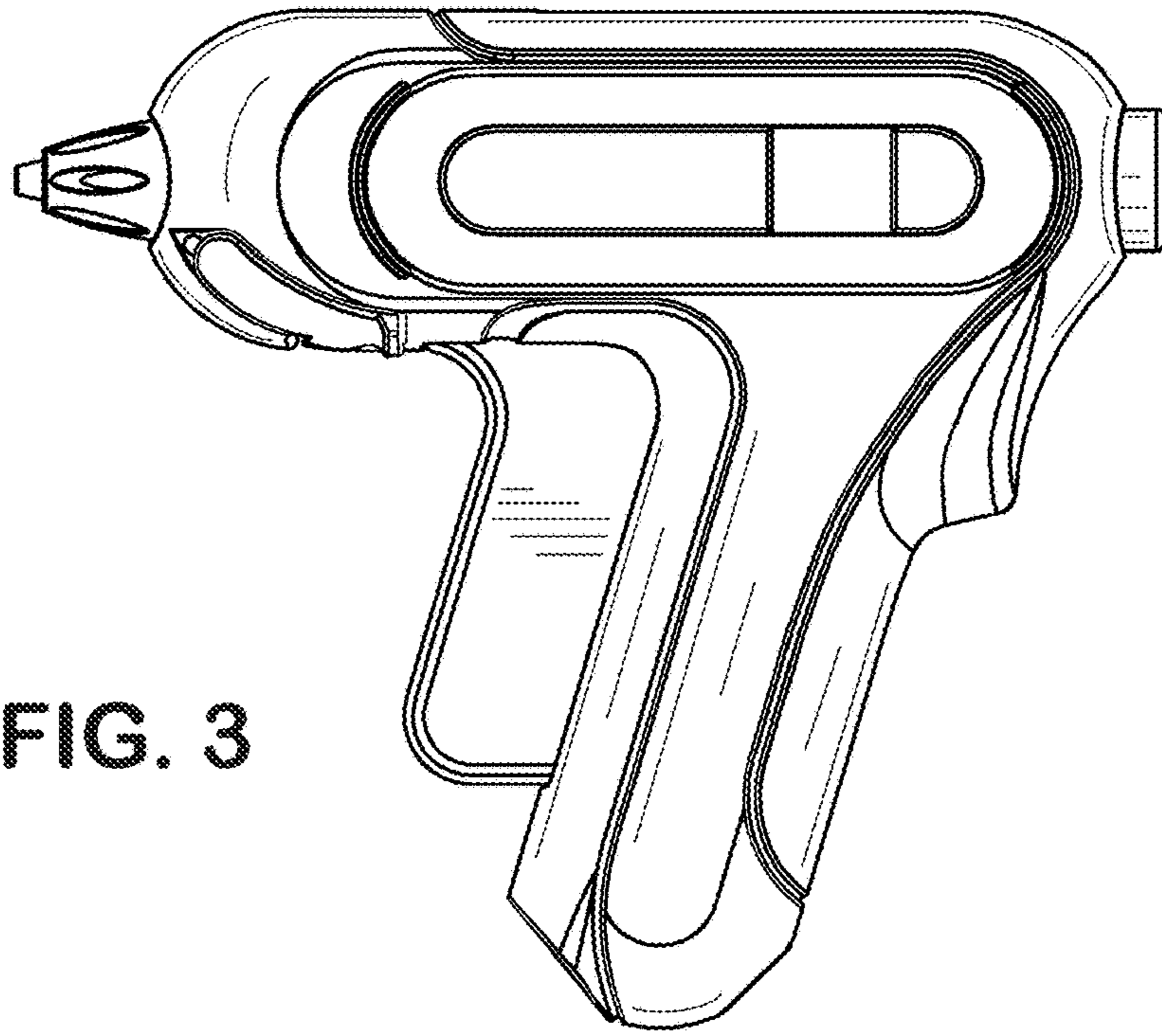

FIG. 3

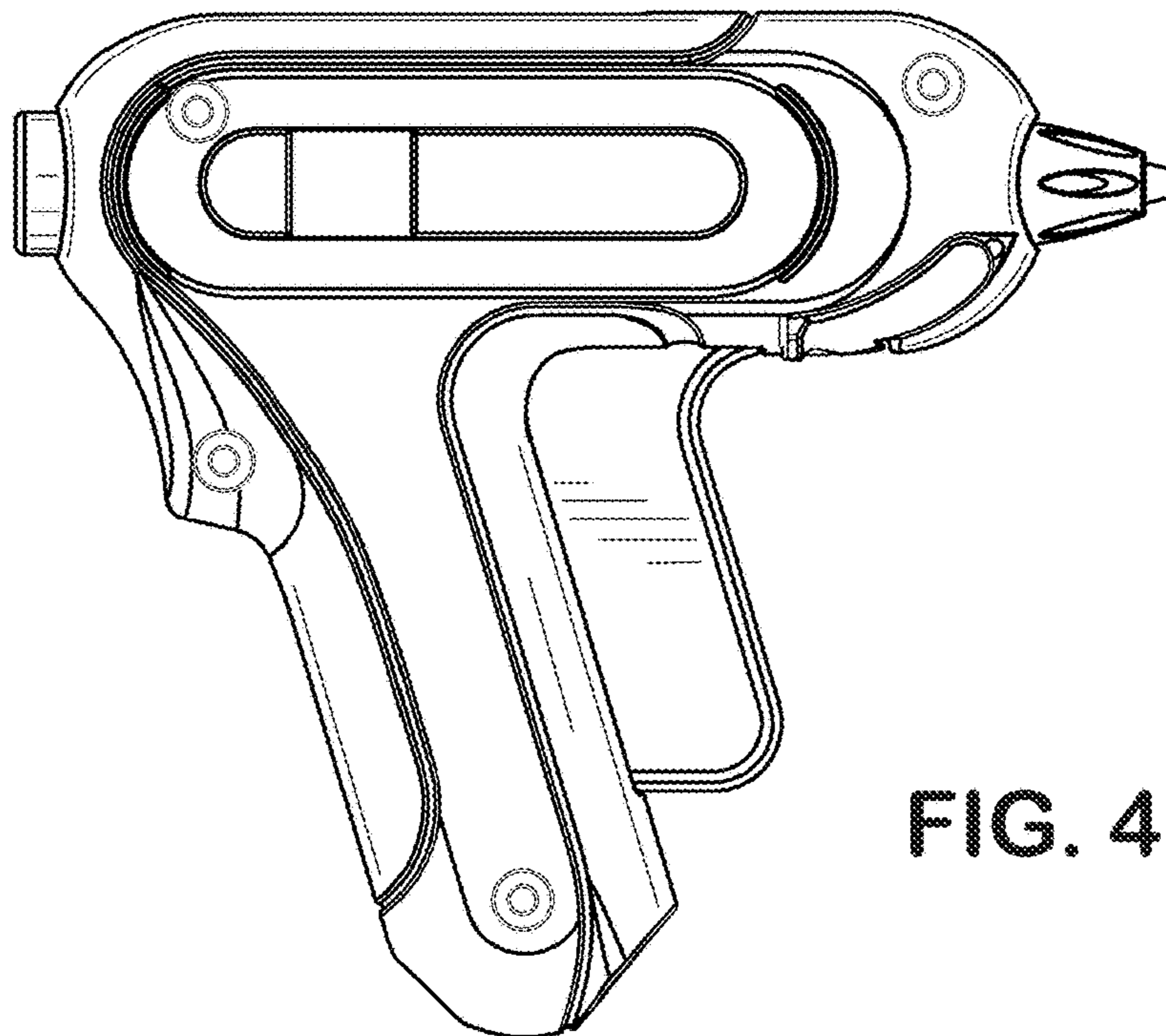

FIG. 4

FIG. 5

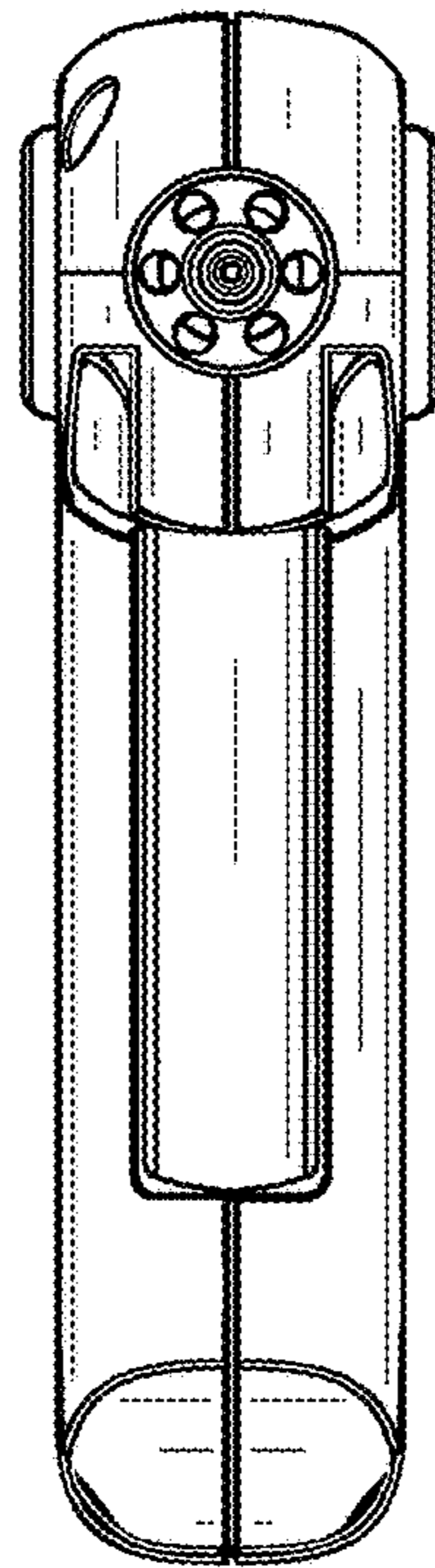
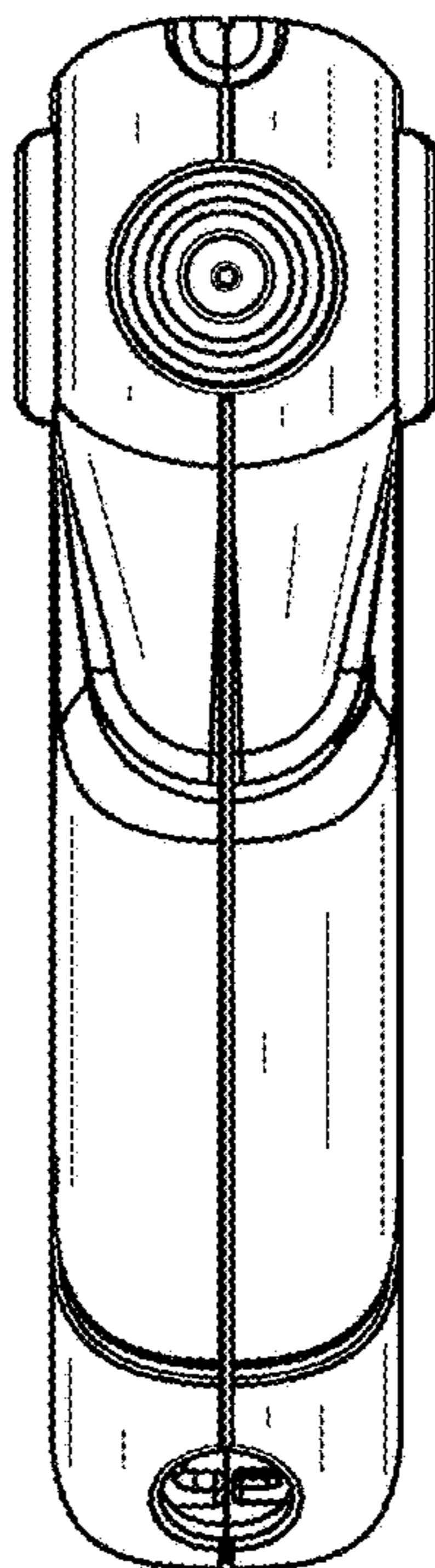

FIG. 6



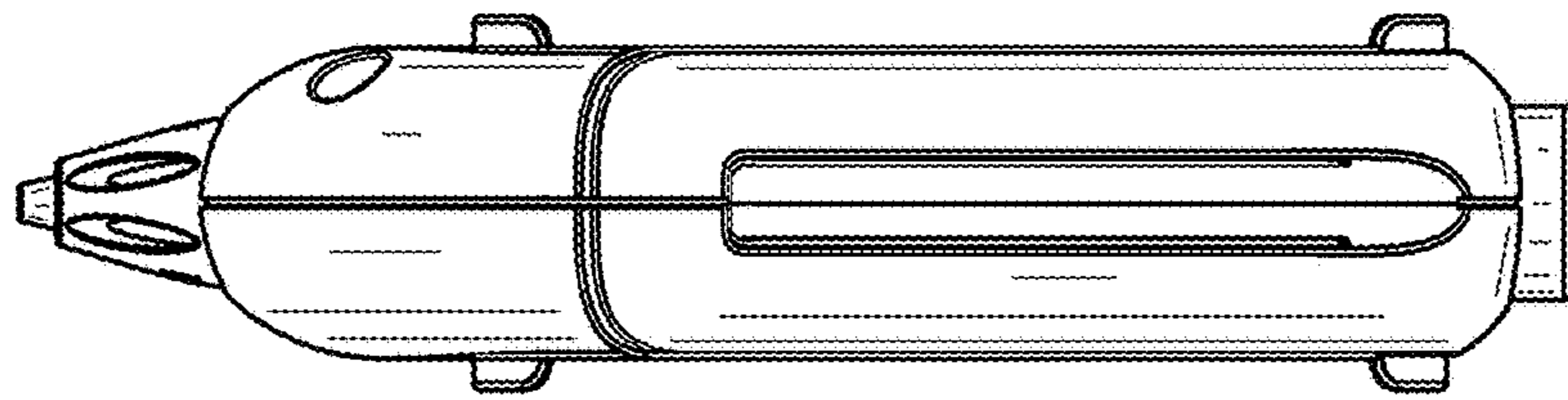

FIG. 7

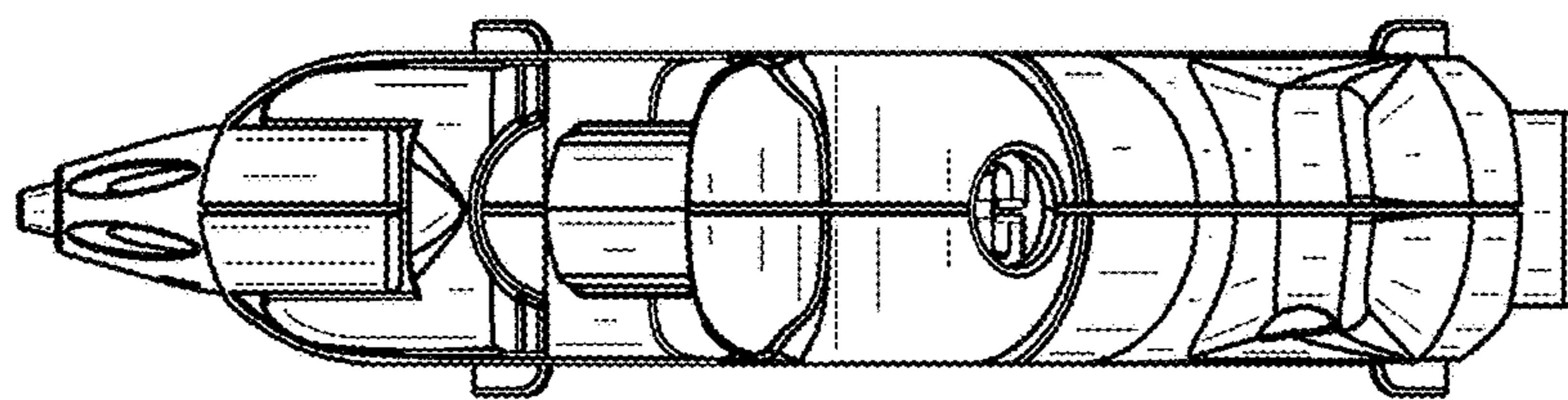

FIG. 8