



US00D844984S

(12) **United States Design Patent** (10) **Patent No.:** **US D844,984 S**  
**Hyma et al.** (45) **Date of Patent:** **\*\* Apr. 9, 2019**

(54) **WRENCH CASE**  
 (71) Applicant: **Milwaukee Electric Tool Corporation**,  
 Brookfield, WI (US)  
 (72) Inventors: **Steven W. Hyma**, Milwaukee, WI  
 (US); **Joseph M. DeBaker**, Greenfield,  
 WI (US); **Scott M. Hangartner**, Butler,  
 WI (US)

(73) Assignee: **Milwaukee Electric Tool Corporation**,  
 Brookfield, WI (US)

(\*\*) Term: **15 Years**

(21) Appl. No.: **29/592,162**

(22) Filed: **Jan. 27, 2017**

(51) **LOC (11) Cl.** ..... **03-01**

(52) **U.S. Cl.**  
 USPC ..... **D3/282; D3/284; D3/905**

(58) **Field of Classification Search**  
 USPC ..... D3/203.2, 203.3, 203.6, 273, 279, 276,  
 D3/284, 294, 302, 905, 274, 281, 282,  
 D3/283, 295  
 CPC ..... B25H 3/00; B25H 3/003; B25H 3/006;  
 B25H 3/02-3/028; A45C 5/00; A45C  
 13/29

See application file for complete search history.

(56) **References Cited**

U.S. PATENT DOCUMENTS

D334,534 S \* 4/1993 Friz ..... D3/905  
 5,855,158 A 1/1999 Donofrio  
 6,745,869 B2 6/2004 Garrett  
 6,926,241 B2 8/2005 Garrett  
 D541,612 S \* 5/2007 Lin ..... D3/905  
 D604,509 S \* 11/2009 Andrews ..... D3/259  
 D655,503 S \* 3/2012 Deguglimo ..... D3/293  
 D698,549 S \* 2/2014 Qi ..... D3/295  
 D714,552 S \* 10/2014 Jiang ..... B25H 3/022  
 D3/294  
 D715,547 S \* 10/2014 Chen ..... D3/284

D744,751 S \* 12/2015 Weng ..... D3/282  
 D746,589 S \* 1/2016 Lai ..... D3/284  
 9,364,907 B2 1/2016 Bucks  
 2001/0008215 A1\* 7/2001 Colombo ..... B25H 3/003  
 206/379  
 2004/0128836 A1 7/2004 Garrett  
 (Continued)

FOREIGN PATENT DOCUMENTS

DE 7312419 9/1973  
 DE 2316373 10/1973  
 (Continued)

*Primary Examiner* — Jennifer Rivard

*Assistant Examiner* — April Rivas

(74) *Attorney, Agent, or Firm* — Reinhart Boerner Van  
 Deuren S.C.

(57) **CLAIM**

We claim the ornamental design for a wrench case, as shown  
 and described.

**DESCRIPTION**

FIG. 1 is a perspective view of a wrench case.  
 FIG. 2 is a front side view of the wrench case shown in FIG.  
 1.  
 FIG. 3 is a back side view of the wrench case shown in FIG.  
 1.  
 FIG. 4 is a right side view of the wrench case shown in FIG.  
 1.  
 FIG. 5 is a left side view of the wrench case shown in FIG.  
 1.  
 FIG. 6 is a top end view of the wrench case shown in FIG.  
 1; and,  
 FIG. 7 is a bottom end view of the wrench case shown in  
 FIG. 1.  
 The broken lines illustrate portions of the wrench case and  
 form no part of the claimed design.

**1 Claim, 5 Drawing Sheets**

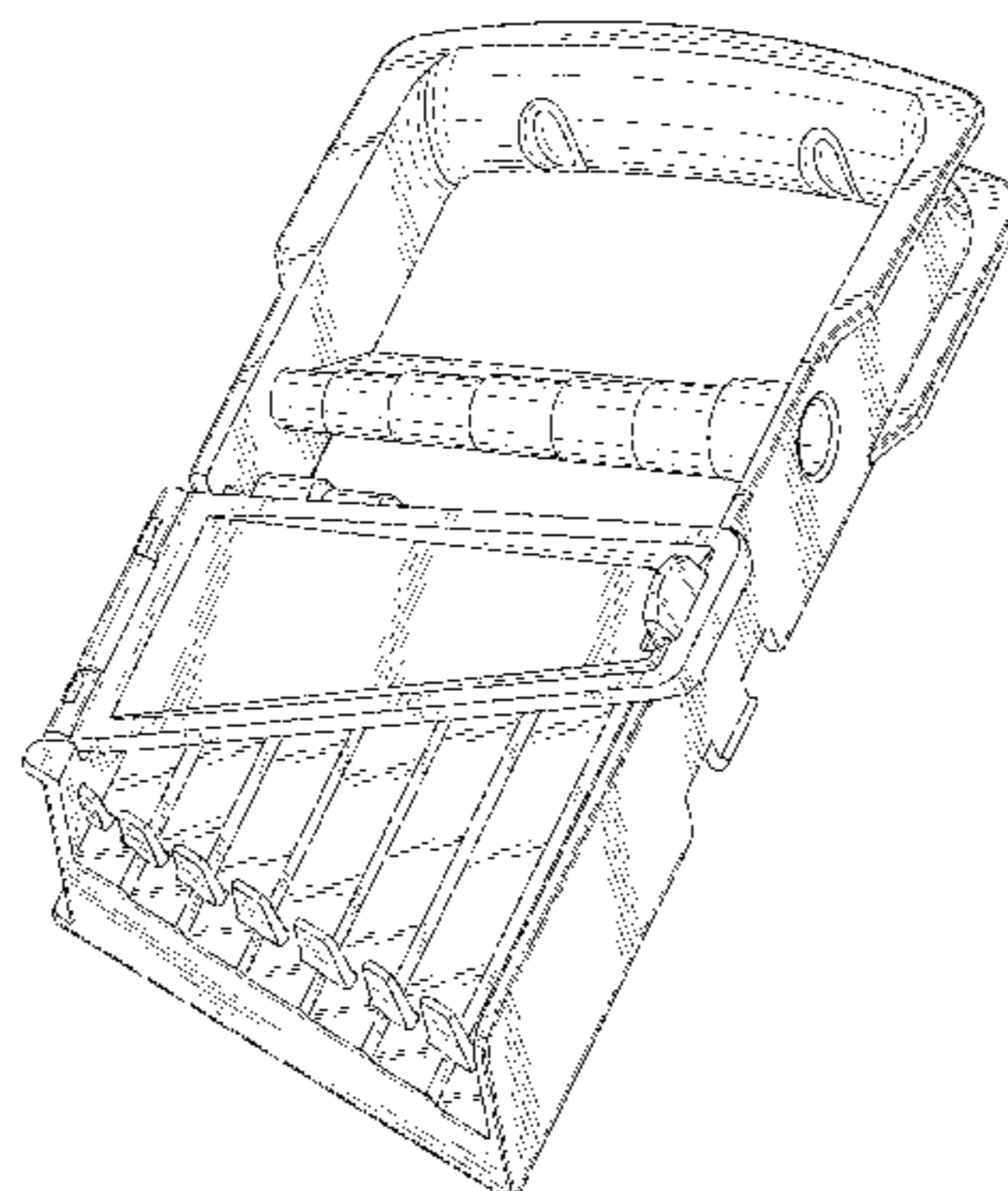

(56)

**References Cited**

U.S. PATENT DOCUMENTS

2005/0029041	A1	2/2005	Garrett	
2005/0173190	A1	8/2005	Garrett	
2006/0157299	A1	7/2006	Garrett	
2008/0105489	A1	5/2008	Garrett	
2008/0229590	A1	9/2008	Garrett	
2008/0301954	A1	12/2008	Garrett	
2010/0258465	A1*	10/2010	Gomas	..... B25H 3/003 206/378
2014/0165293	A1*	6/2014	Hermansen	..... B25F 1/02 7/168
2018/0079069	A1*	3/2018	Su	..... B25H 3/003

FOREIGN PATENT DOCUMENTS

DE	2316449	10/1973
DE	7312431	10/1973
DE	29607673	8/1997
EP	1053815	11/2000
FR	1258292	4/1961
GB	2345461	7/2001
WO	WO2012097896	7/2012

\* cited by examiner

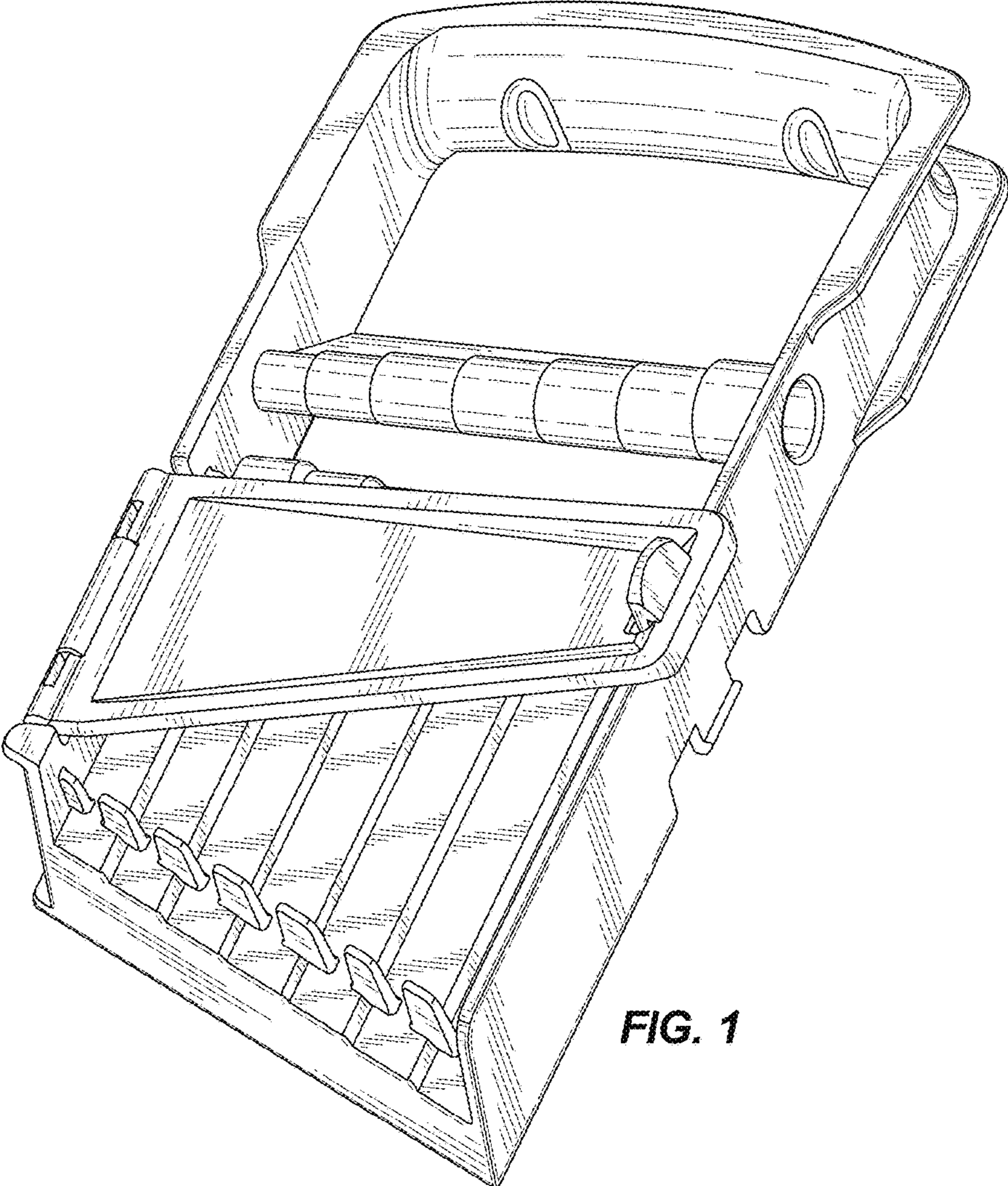
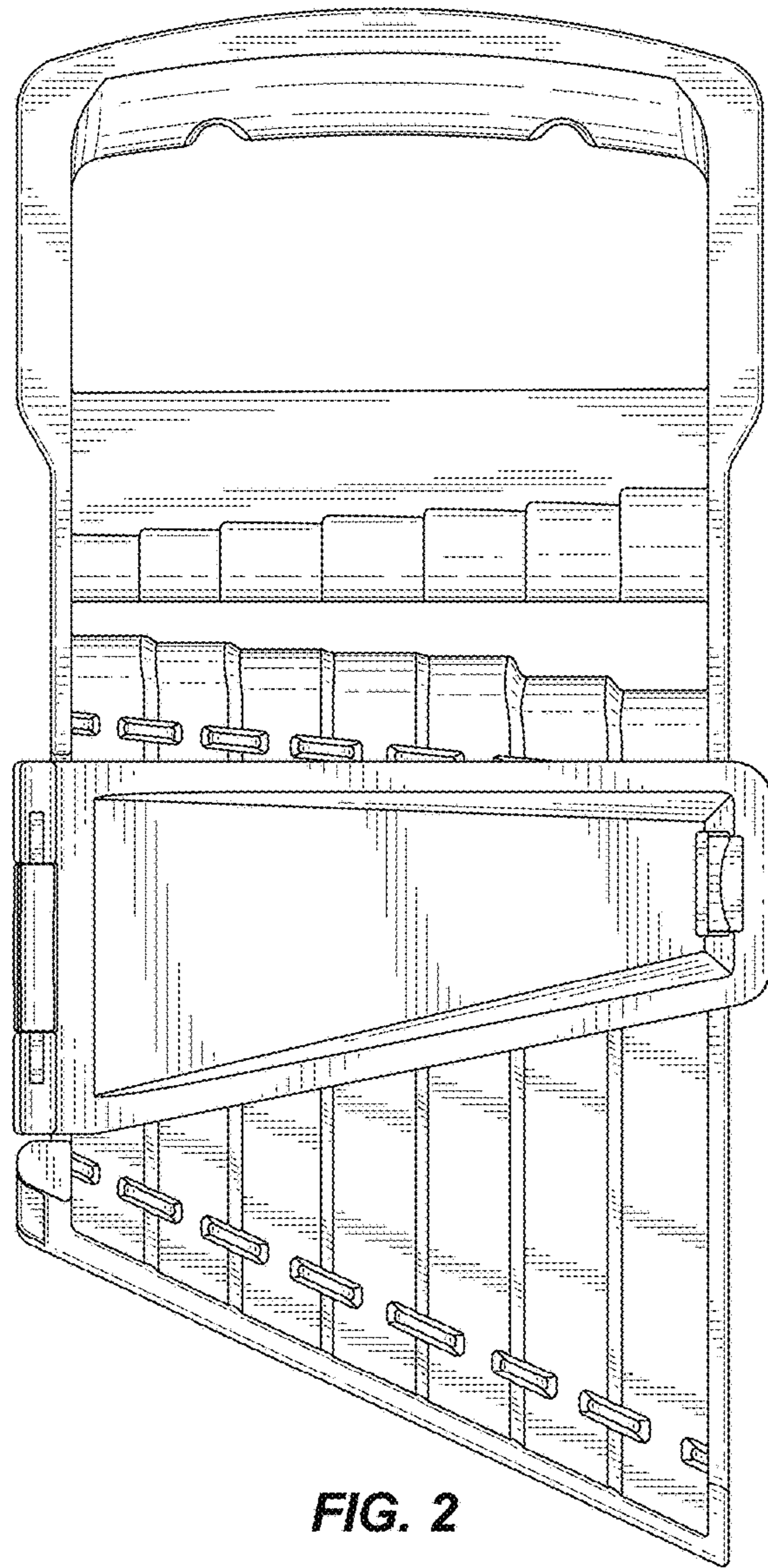
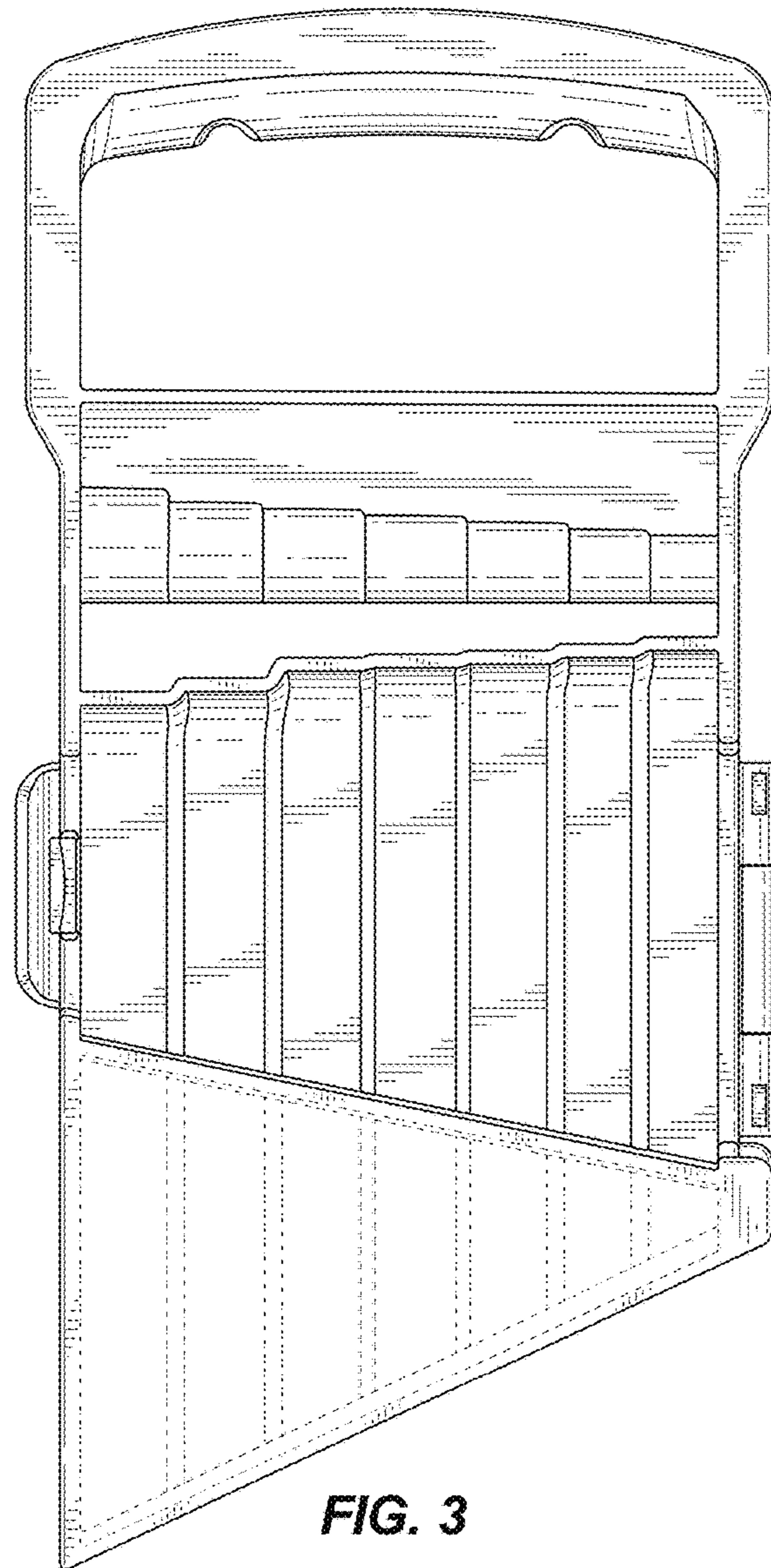

FIG. 1



**FIG. 2**



**FIG. 3**

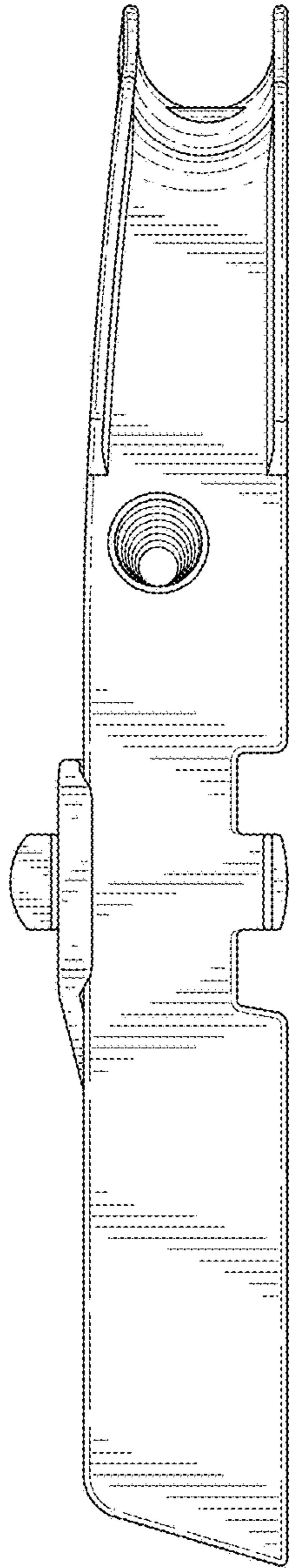

**FIG. 4**

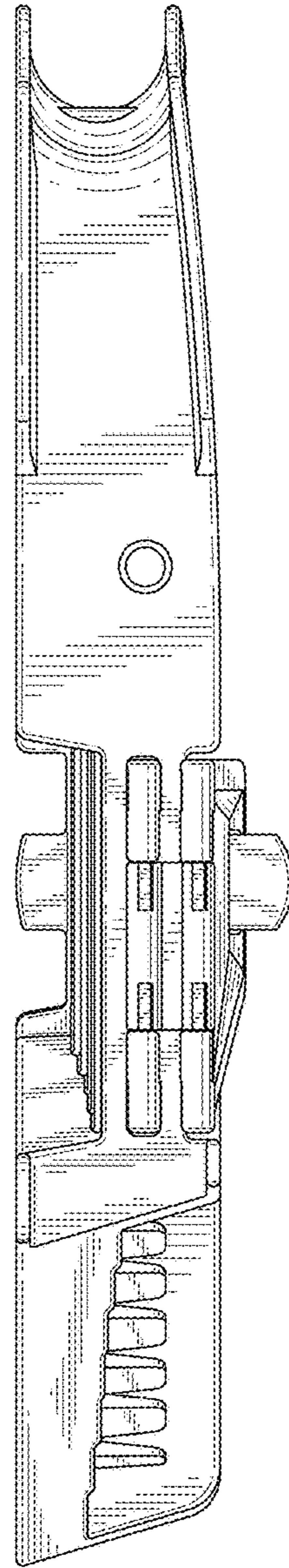

**FIG. 5**

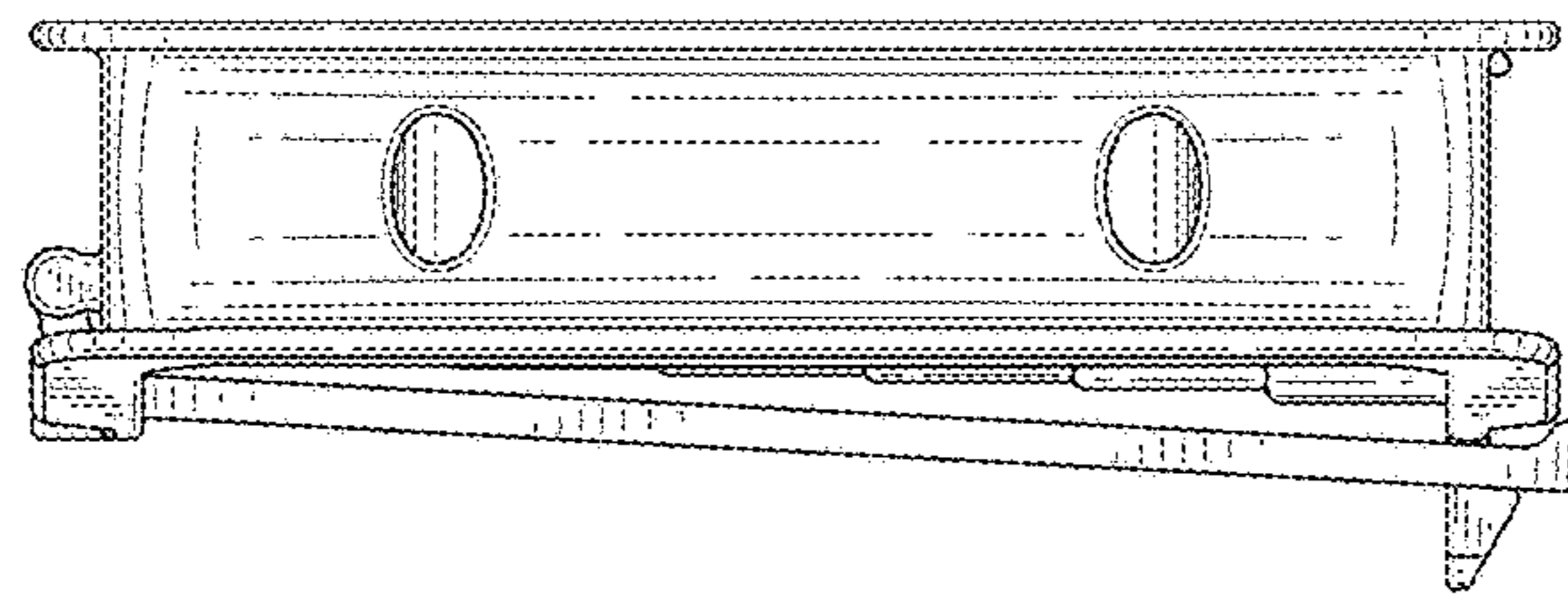

**FIG. 6**

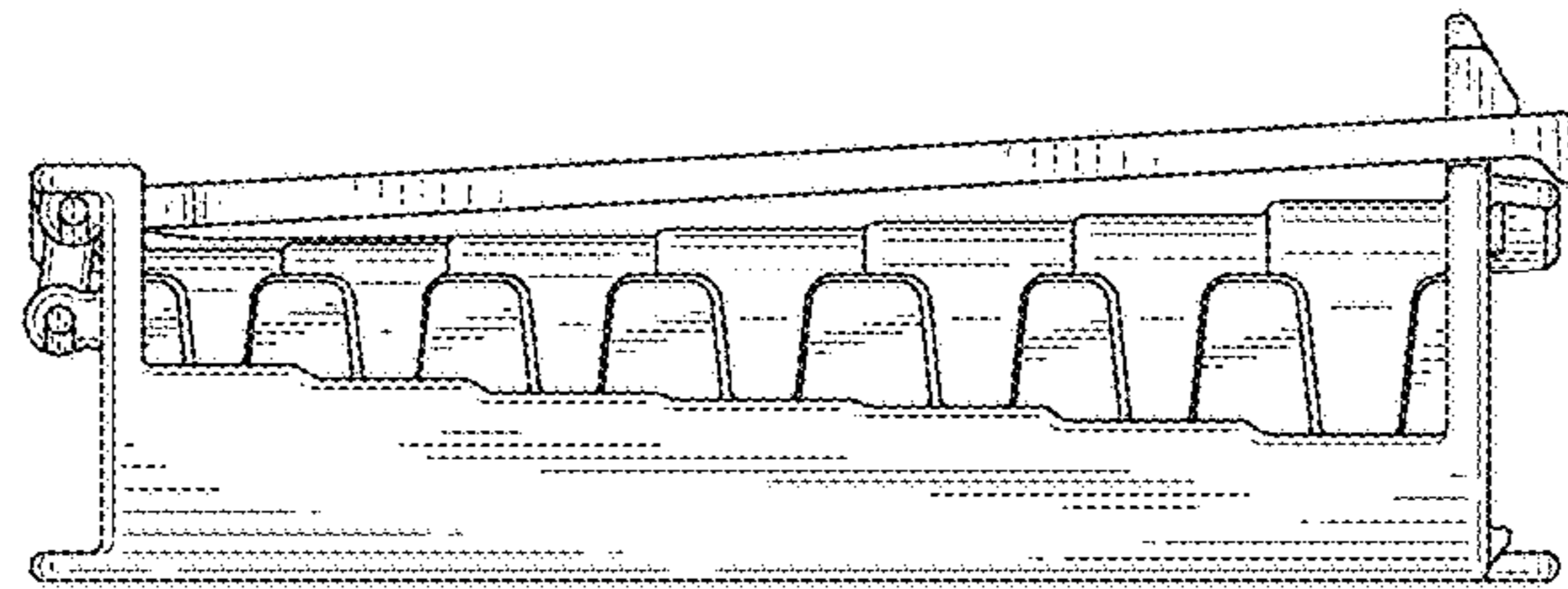

**FIG. 7**