

US00D844854S

(12) **United States Design Patent** (10) **Patent No.:** **US D844,854 S**
Lee (45) **Date of Patent:** **** Apr. 2, 2019**

(54) **FRAME FOR VINYL HOUSE** D422,718 S * 4/2000 Chaney D25/122
6,338,226 B1 * 1/2002 Gauthier A01G 9/14
(71) Applicant: **Heung Chang Lee**, Miryang-si (KR) 52/63
D455,634 S * 4/2002 Hummel D25/124
(72) Inventor: **Heung Chang Lee**, Miryang-si (KR) D519,024 S * 4/2006 Knight D8/395
D520,352 S * 5/2006 Knight D8/395
D732,698 S * 6/2015 Meng D25/61
D826,030 S * 8/2018 Macdonald D8/349
(**) Term: **15 Years** 2009/0071091 A1 * 3/2009 Ode A01G 9/14
(21) Appl. No.: **29/611,763** 52/653.1

(22) Filed: **Jul. 25, 2017**

(30) **Foreign Application Priority Data**

Jun. 12, 2017 (KR) 30-2017-0026457

(51) **LOC (11) Cl.** **25-01**

(52) **U.S. Cl.**
USPC **D25/61; D25/122**

(58) **Field of Classification Search**
USPC D25/15, 38.1, 41.1, 61, 119-126, 131,
D25/132, 164
CPC ... E04F 13/08; E04F 13/0826; E04F 13/0889;
E04F 13/12; E04H 1/00; A01G 9/14;
A01G 9/1407; E04B 7/026; E04B 7/08
See application file for complete search history.

(56) **References Cited**

U.S. PATENT DOCUMENTS

3,004,543 A * 10/1961 Pinet A01G 9/1407
135/137
D299,543 S * 1/1989 Phillips D25/164
D389,526 S * 1/1998 Callas D20/43
D421,688 S * 3/2000 Doud D25/122

FOREIGN PATENT DOCUMENTS

CN 303937417 * 11/2016
KR 300764768.0000 * 10/2014
KR 300796099.0000 * 5/2015

* cited by examiner

Primary Examiner — Leanne Was-Englehart
(74) *Attorney, Agent, or Firm* — Im IP Law; C. Andrew
Im; Chai Im

(57) **CLAIM**

The ornamental design for a frame for vinyl house, as shown
and described.

DESCRIPTION

FIG. 1 is a perspective view of a frame for vinyl house
showing my new design;
FIG. 2 is a front view of the frame for vinyl house thereof;
FIG. 3 is a left view of the frame for vinyl house thereof;
FIG. 4 is a top view of the frame for vinyl house thereof;
and,
FIG. 5 is a bottom view of the frame for vinyl house thereof.

1 Claim, 5 Drawing Sheets

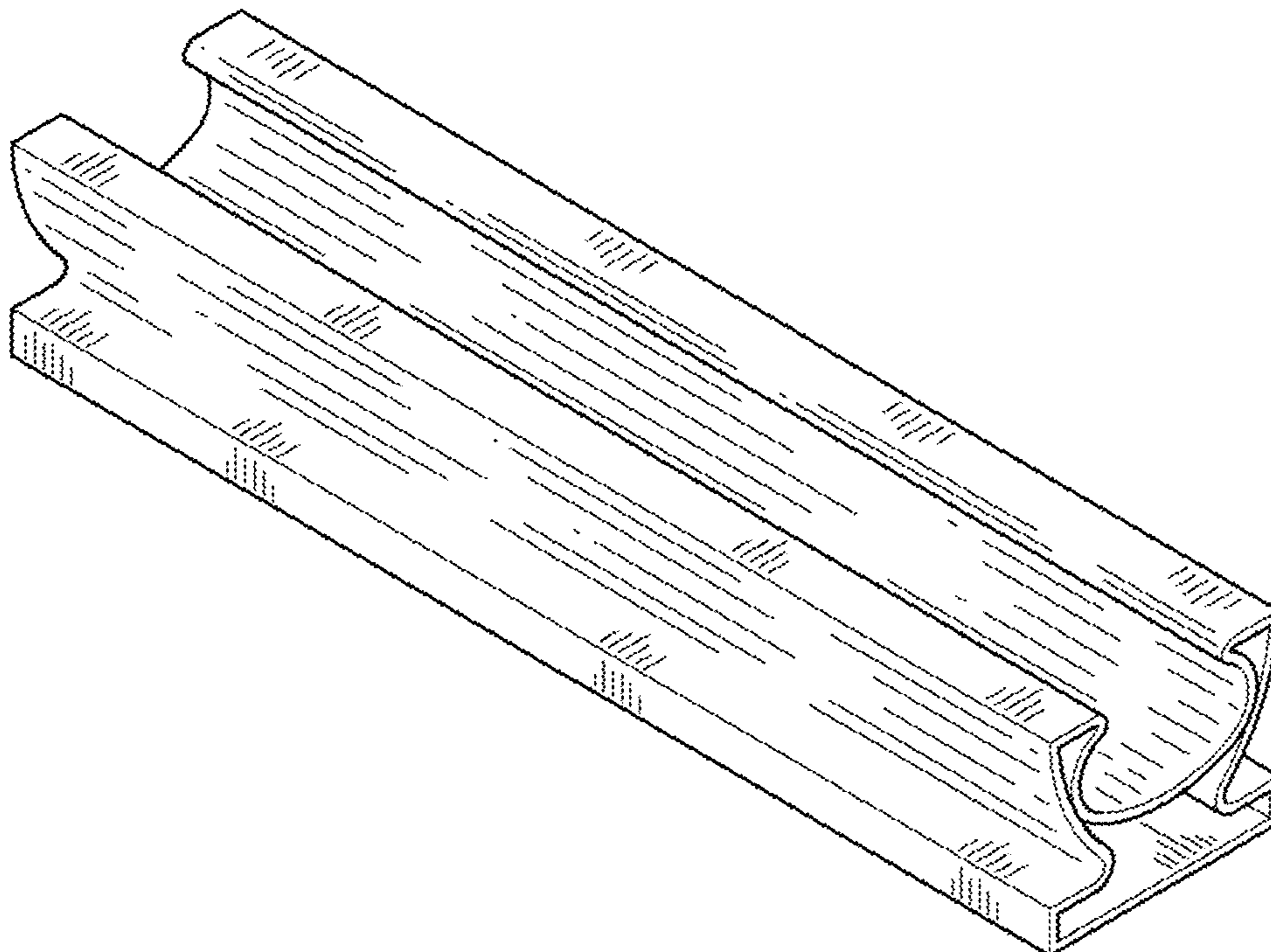

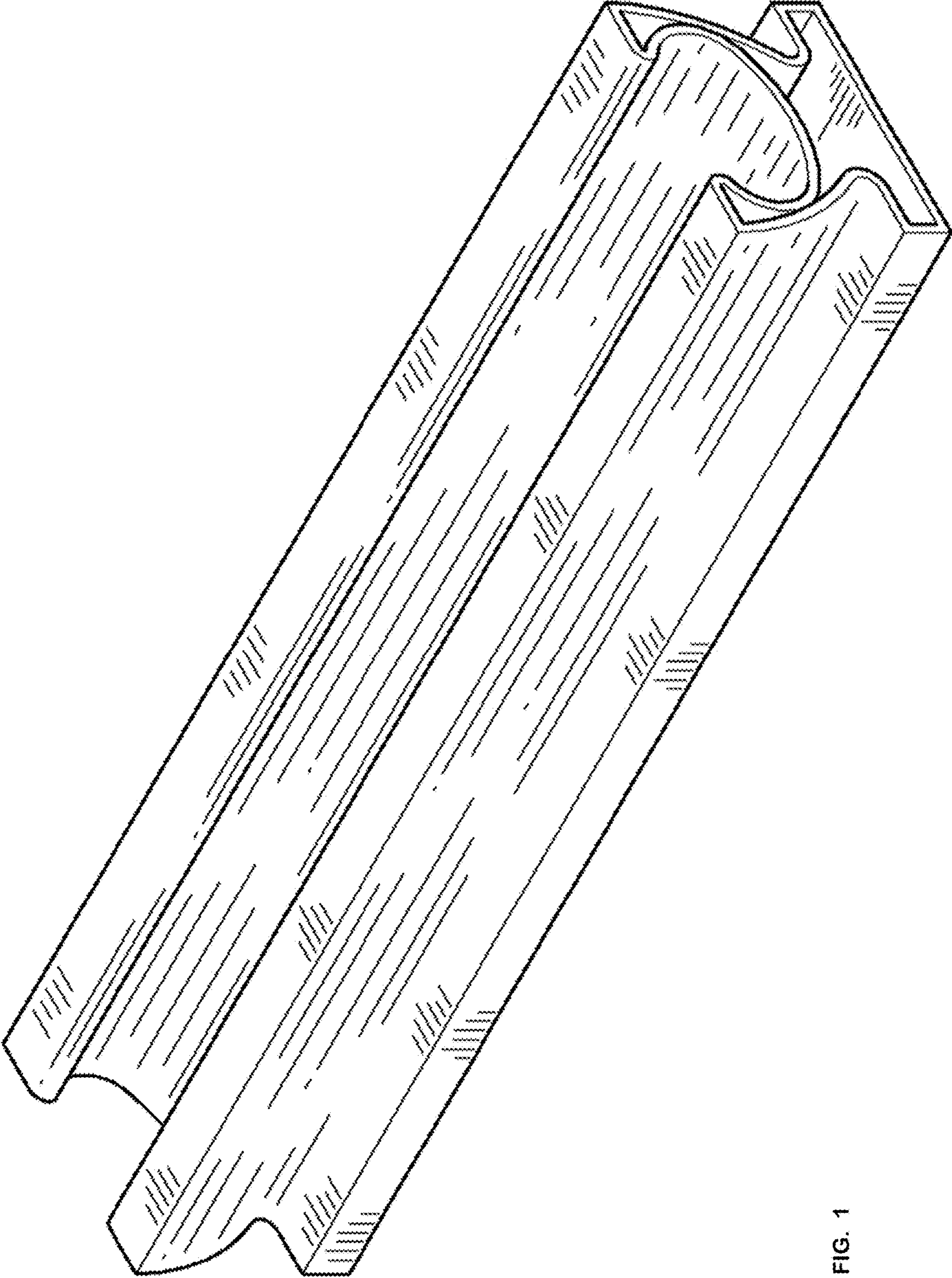

FIG. 1

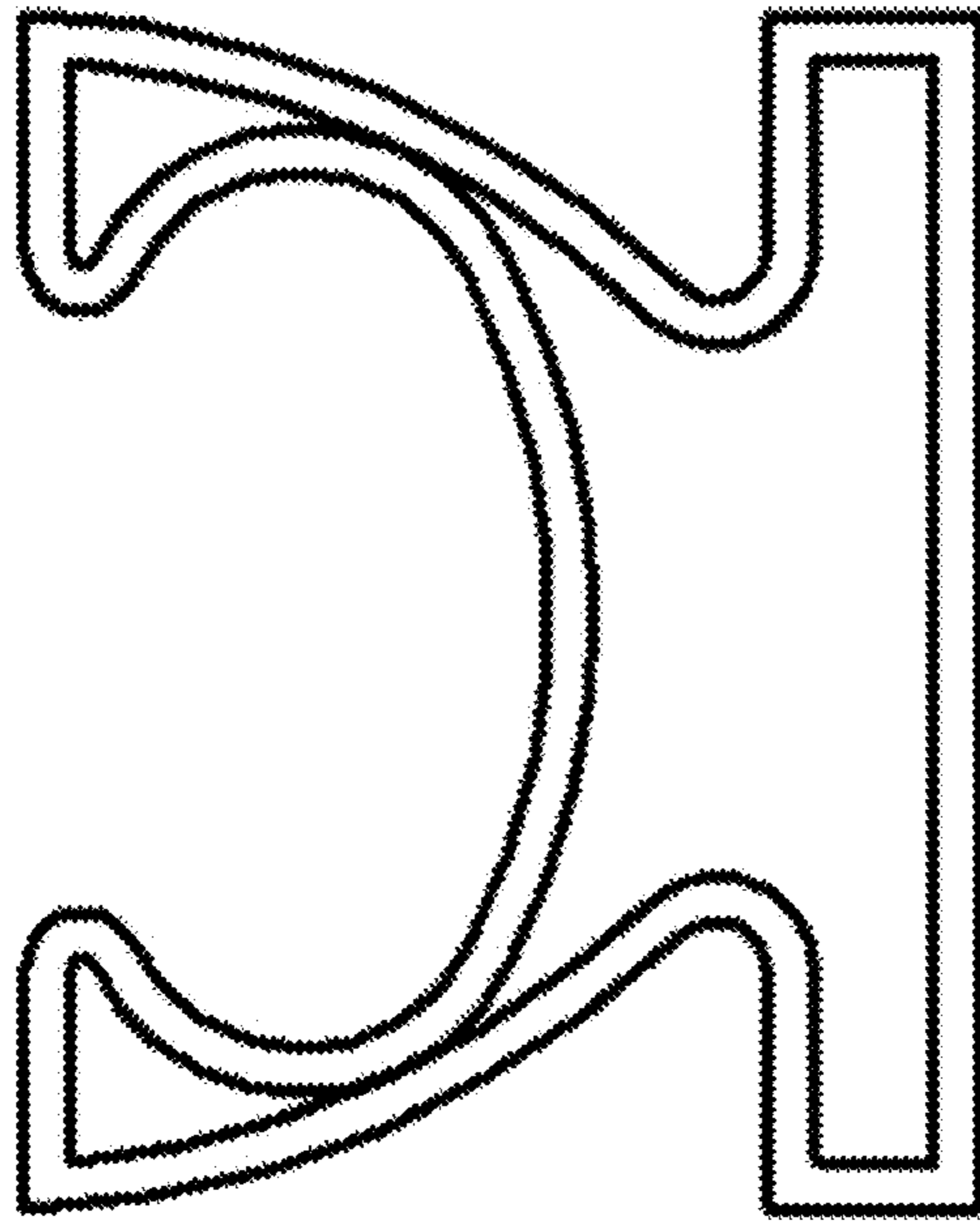

FIG. 2

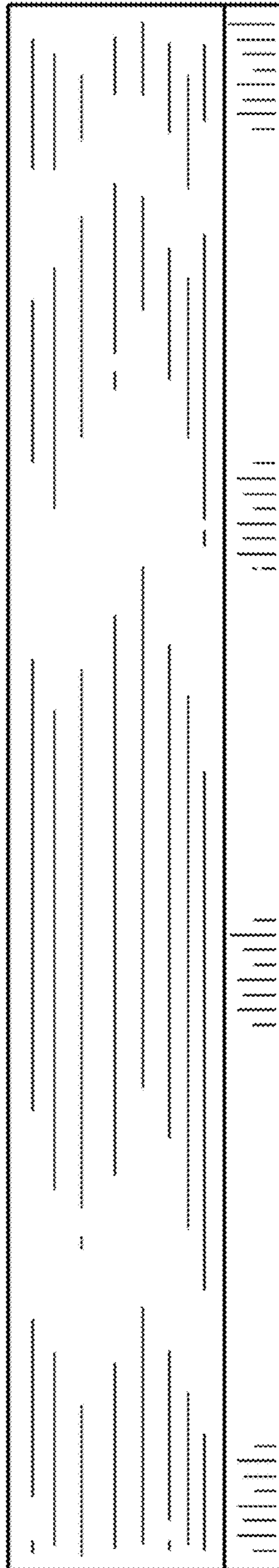

FIG. 3

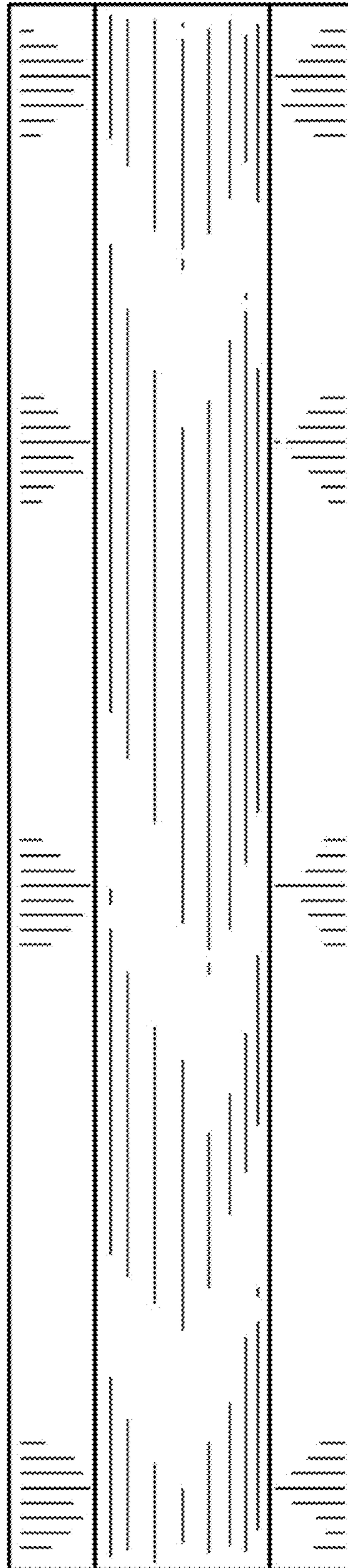

FIG. 4

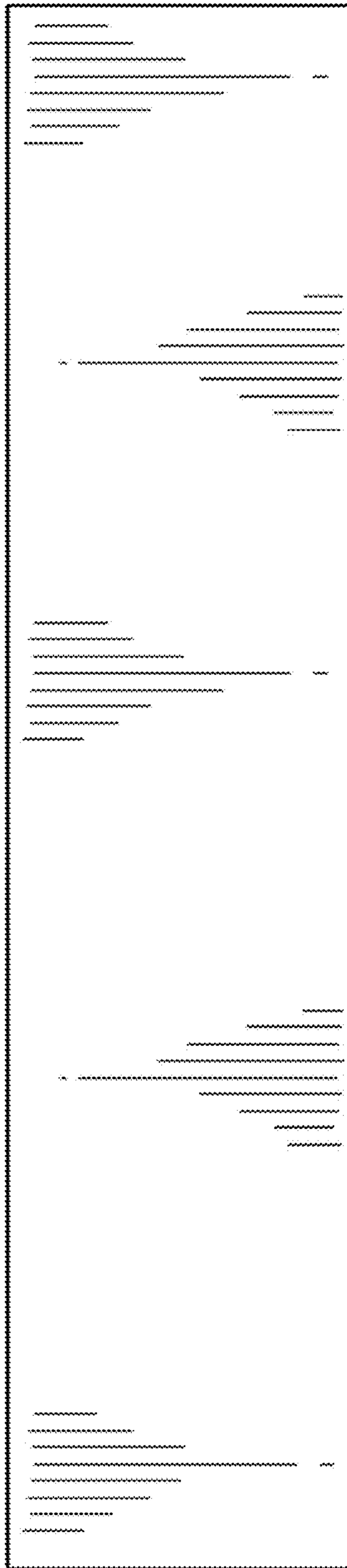

FIG. 5