



US00D844848S

(12) **United States Design Patent**
Cox et al.

(10) **Patent No.:** **US D844,848 S**

(45) **Date of Patent:** **** Apr. 2, 2019**

(54) **DOOR**

(71) Applicant: **JELD-WEN, Inc.**, Klamath Falls, OR
(US)

(72) Inventors: **Randy G. Cox**, Klamath Falls, OR
(US); **Sean R. Broker**, Auburn, MI
(US)

(73) Assignee: **JELD-WEN, Inc.**, Klamath Falls, OR
(US)

(**) Term: **15 Years**

(21) Appl. No.: **29/617,053**

(22) Filed: **Sep. 11, 2017**

Related U.S. Application Data

(62) Division of application No. 29/550,310, filed on Dec.
31, 2015, now Pat. No. Des. 797,312.

(51) **LOC (11) Cl.** **25-02**

(52) **U.S. Cl.**
USPC **D25/48.3**

(58) **Field of Classification Search**
USPC D25/48.3, 48.4, 48.5, 48.6, 48.7, 48.8,
D25/138

(Continued)

(56) **References Cited**

U.S. PATENT DOCUMENTS

432,504 A * 7/1890 Amsden E06B 3/5892
52/455
926,361 A * 6/1909 Sjobring E06B 3/5892
52/455

(Continued)

FOREIGN PATENT DOCUMENTS

CA 158033 * 12/2014
CA 159667 * 12/2014

(Continued)

OTHER PUBLICATIONS

Cox, Randy G. et al., "Door," U.S. Appl. No. 29/560,236, filed Apr.
4, 2016.

(Continued)

Primary Examiner — Leanne Was-Englehart
(74) *Attorney, Agent, or Firm* — Stoel Rives LLP; Robert
R. Teel

(57) **CLAIM**

We claim the ornamental design for a door, as shown and
described.

DESCRIPTION

FIG. 1 is an isometric view of a door, according to a first
embodiment.

FIG. 2 is a front view of the door of FIG. 1.

FIG. 3 is an enlarged fragmentary section view of the door
of FIG. 1, taken along line 3-3 of FIG. 2.

FIG. 4 is a top view of the door of FIG. 1, of which a bottom
view is identical.

FIG. 5 is a right side view of the door of FIG. 1, of which
a left side view is identical.

FIG. 6 is an isometric view of a door, according to a second
embodiment.

FIG. 7 is a front view of the door of FIG. 6.

FIG. 8 is an enlarged fragmentary section view of the door
of FIG. 6, taken along line 8-8 of FIG. 7.

FIG. 9 is a top view of the door of FIG. 6, of which a bottom
view is identical.

FIG. 10 is a right side view of the door of FIG. 6, of which
a left side view is identical.

FIG. 11 is an isometric view of a door, according to a third
embodiment.

FIG. 12 is a front view of the door of FIG. 11.

FIG. 13 is an enlarged fragmentary section view of the door
of FIG. 11, taken along line 13-13 of FIG. 12.

FIG. 14 is a top view of the door of FIG. 11, of which a
bottom view is identical; and,

FIG. 15 is a right side view of the door of FIG. 11, of which
a left side view is identical.

(Continued)

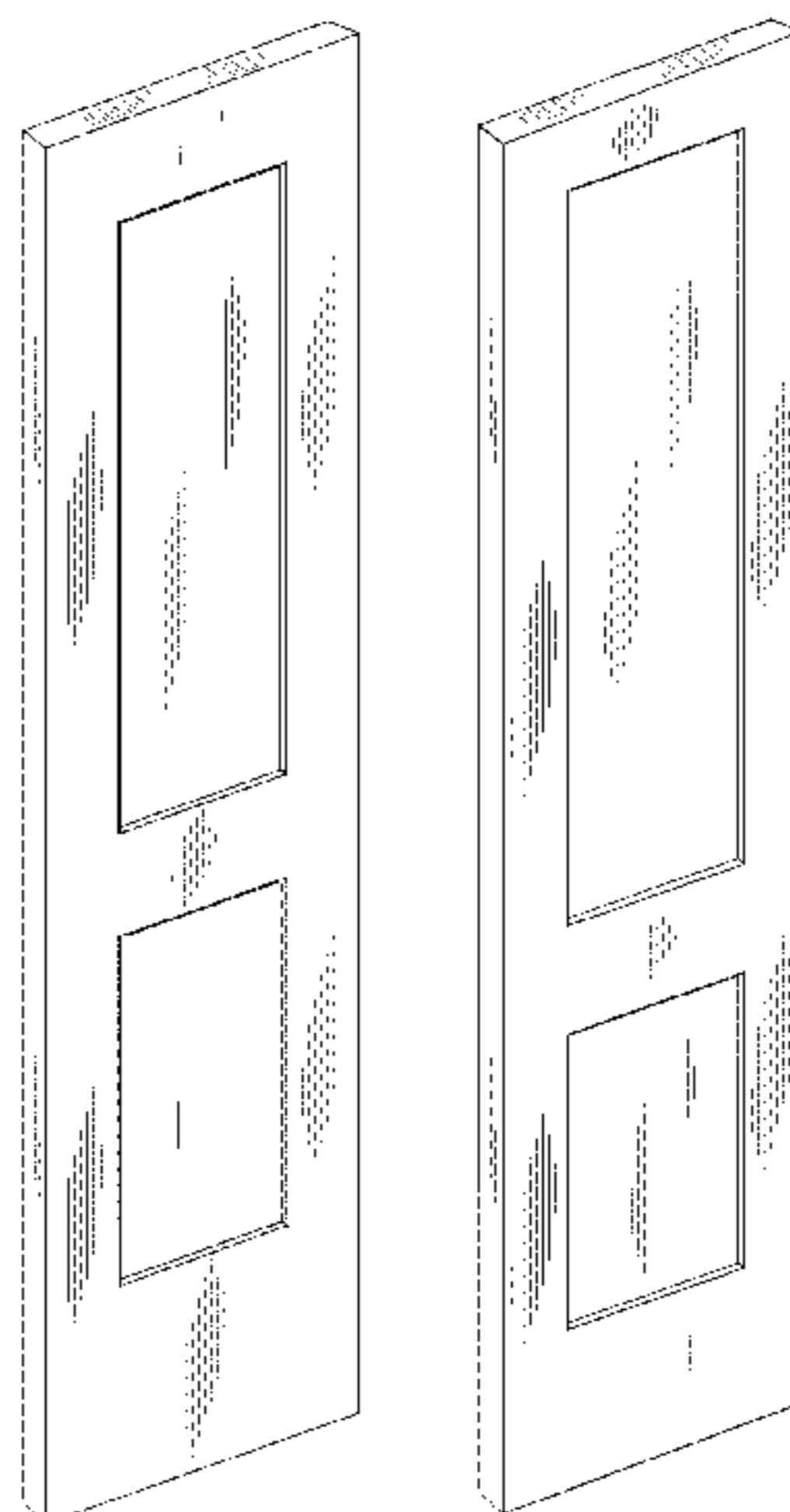

In each of FIGS. 3, 8, and 13, the lateral broken lines depict the limits of the enlarged view taken from, respectively, FIGS. 2, 7, and 12. The middle wavy broken lines and broken-line hatching indicating a sectional view are not intended to illustrate the internal construction of the door. The aforementioned broken lines form no part of the claimed design.

1 Claim, 3 Drawing Sheets

(58) **Field of Classification Search**

CPC E06B 3/58; E06B 3/72; E06B 3/78; E06B 3/485; E06B 3/4636; E06B 3/5892; E06B 2003/7044; E06B 1/04; E06B 5/00
See application file for complete search history.

(56) **References Cited**

U.S. PATENT DOCUMENTS

956,556	A *	5/1910	Wege	E06B 3/5892 5/280
985,912	A *	3/1911	Lindros	E06B 3/5892 52/455
986,013	A *	3/1911	Klemm	E06B 3/728 52/455
988,574	A *	4/1911	Jones	E06B 3/5892 52/455
1,021,053	A *	3/1912	Lemperera	E06B 3/5892 52/455
1,086,934	A *	2/1914	Parish	E06B 3/5892 52/455
1,094,025	A *	4/1914	Scott	E04B 1/0046 52/455

1,391,949	A *	9/1921	Gogay	E06B 3/5892 52/455
1,466,650	A *	8/1923	Peterson	E06B 3/728 52/455
5,469,903	A	11/1995	Stanley	
D585,143	S *	1/2009	Steiber	D25/48.3
D585,144	S *	1/2009	Steiber	D25/48.3
D756,534	S *	5/2016	Allen	D25/48.3
D796,060	S	8/2017	Cox et al.	
D797,312	S *	9/2017	Cox	D25/48.3

FOREIGN PATENT DOCUMENTS

EM	000802152-0002	1/2008
EM	000802152-0010	1/2008
EM	001393474-0005	12/2013
EM	001393474-0006	12/2013
EM	001393474-0011	12/2013
EM	001393474-0012	12/2013
EM	001393474-0006	* 1/2014
EM	001393474-0012	* 1/2014
WO	DM/057786	12/2001

OTHER PUBLICATIONS

Cox, Randy G. et al., "Door Facing," U.S. Appl. No. 29/550,306, filed Dec. 31, 2015.
Cox, Randy G. et al., "Door Facing," U.S. Appl. No. 29/550,306, Interview Summary and Office Action Response, filed May 23, 2017, 6 pages.
Jeld-Wen, Inc., "Interior Doors Molded and Flushed, product brochure," available as least as early as Jun. 16, 2012, 44 pages.
Jeld-Wen, Inc., "Premium Wood—Panel Doors," archived at https://web.archive.org/web/20120510212122/http://en.jeld-wen.ca/interior_doors/natural_wood/premium_wood_e/panel/, archived May 10, 2012, 3 pages.

* cited by examiner

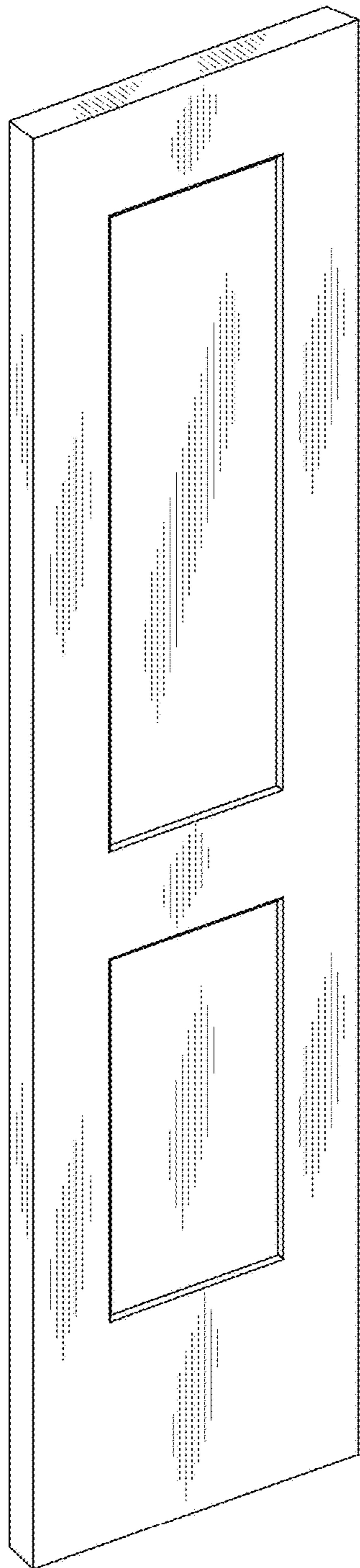

FIG. 1

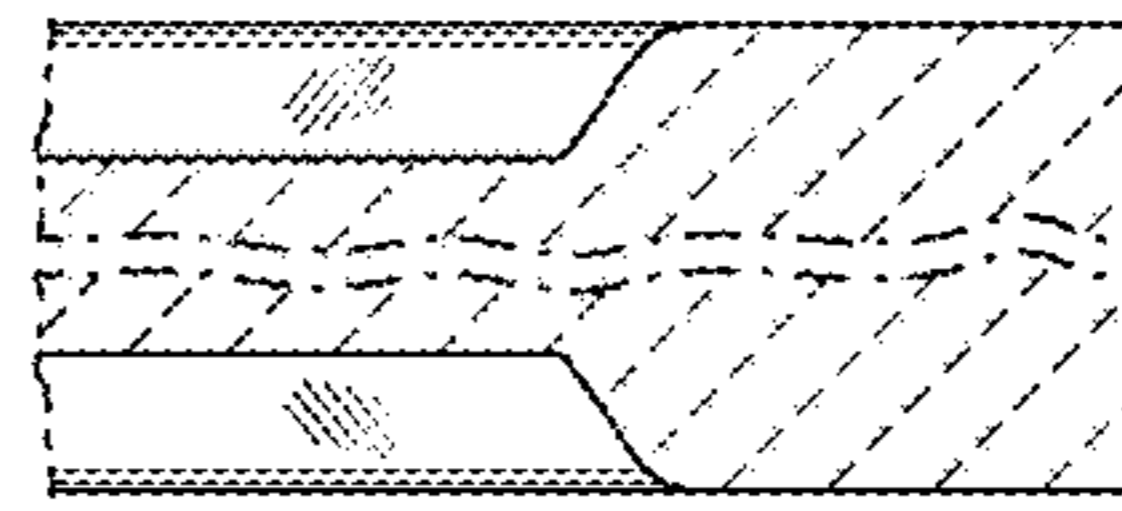

FIG. 3

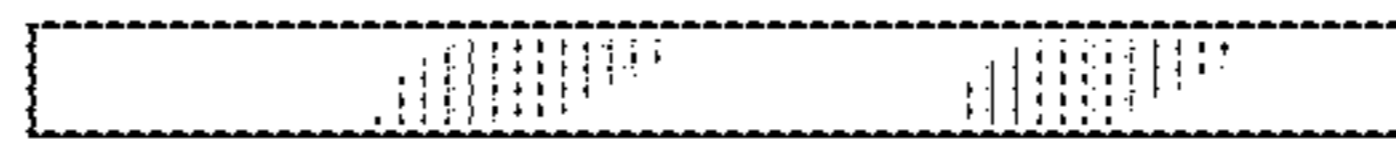

FIG. 4

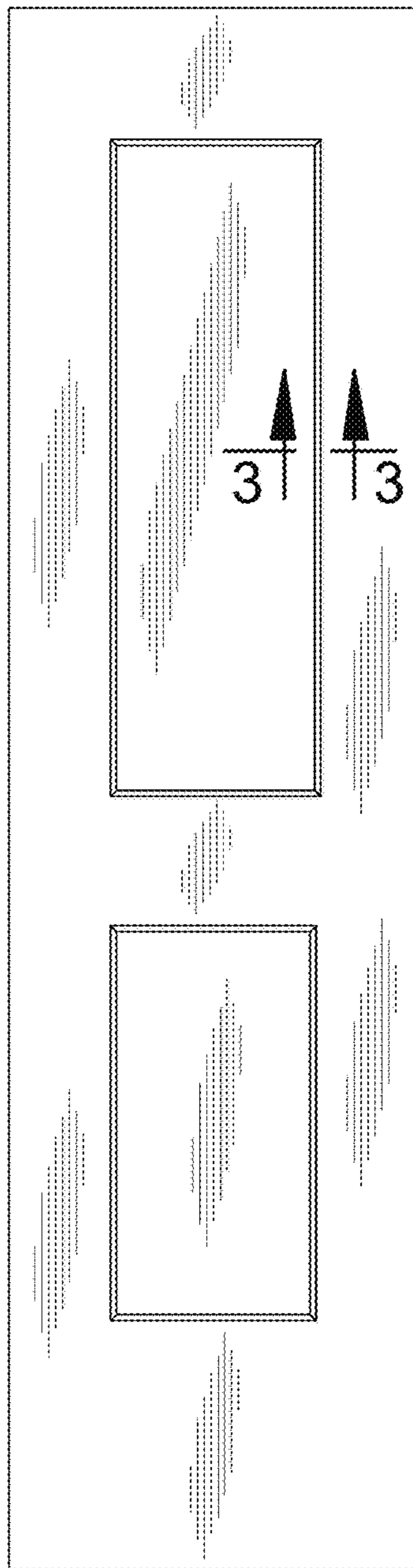

FIG. 2



FIG. 5

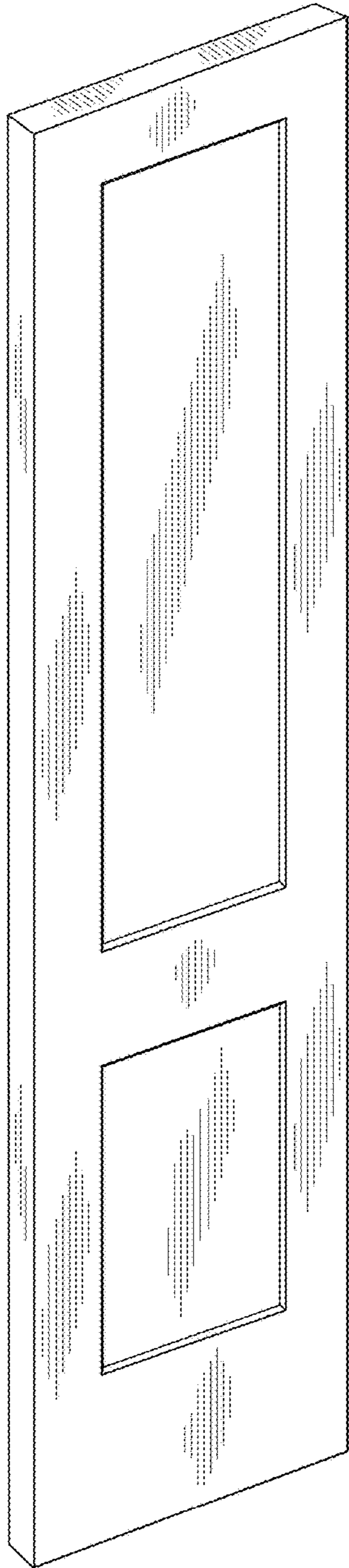

FIG. 6



FIG. 8

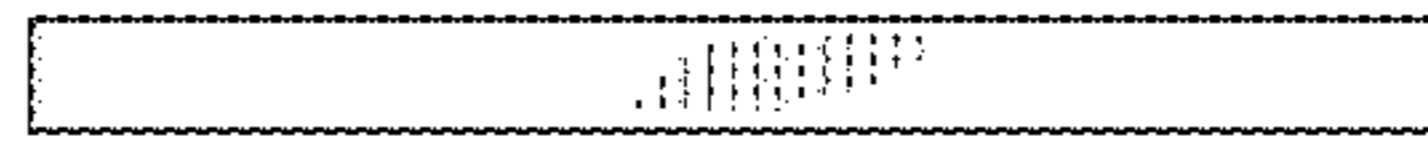

FIG. 9

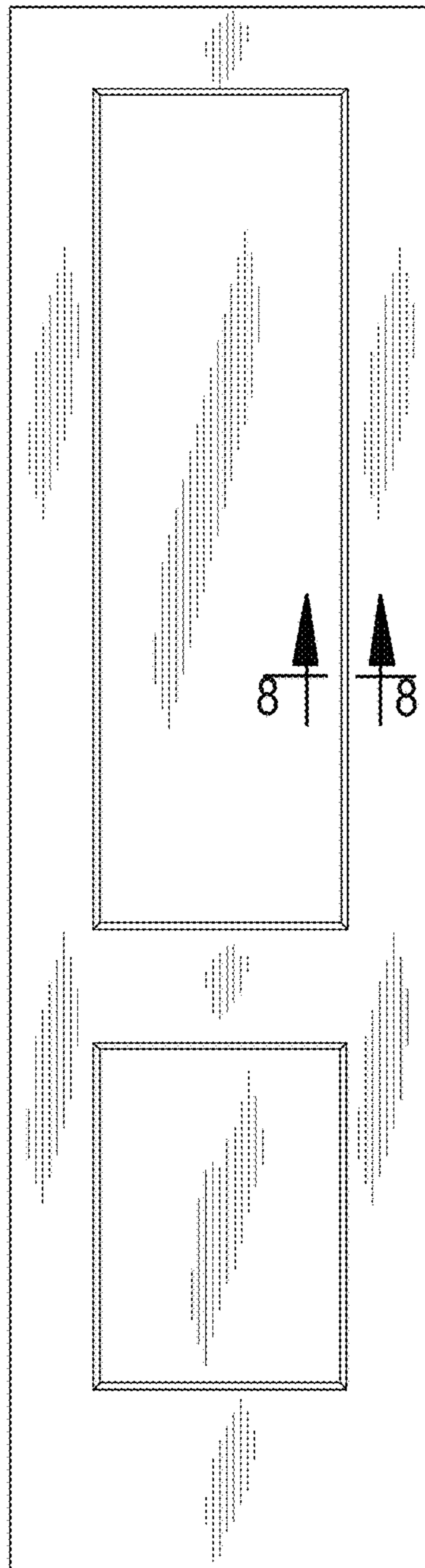

FIG. 7



FIG. 10

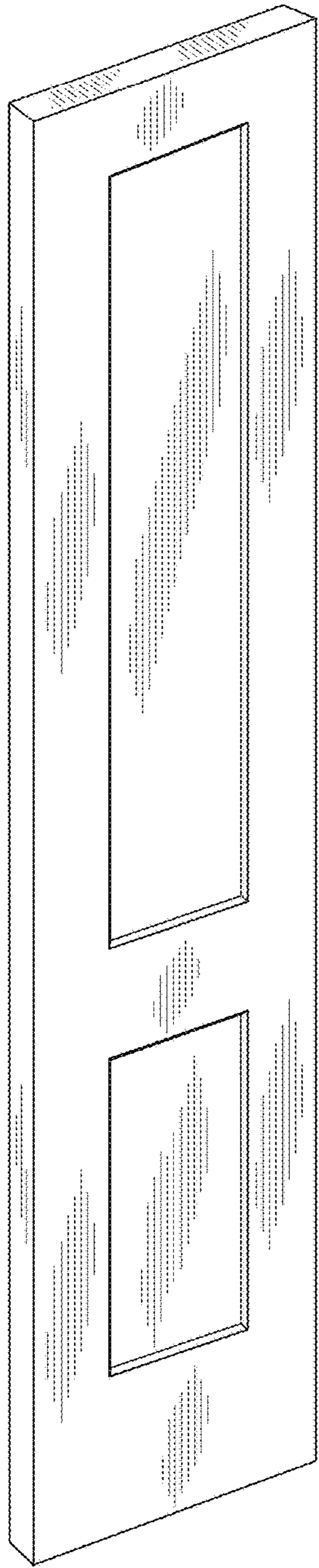

FIG. 11

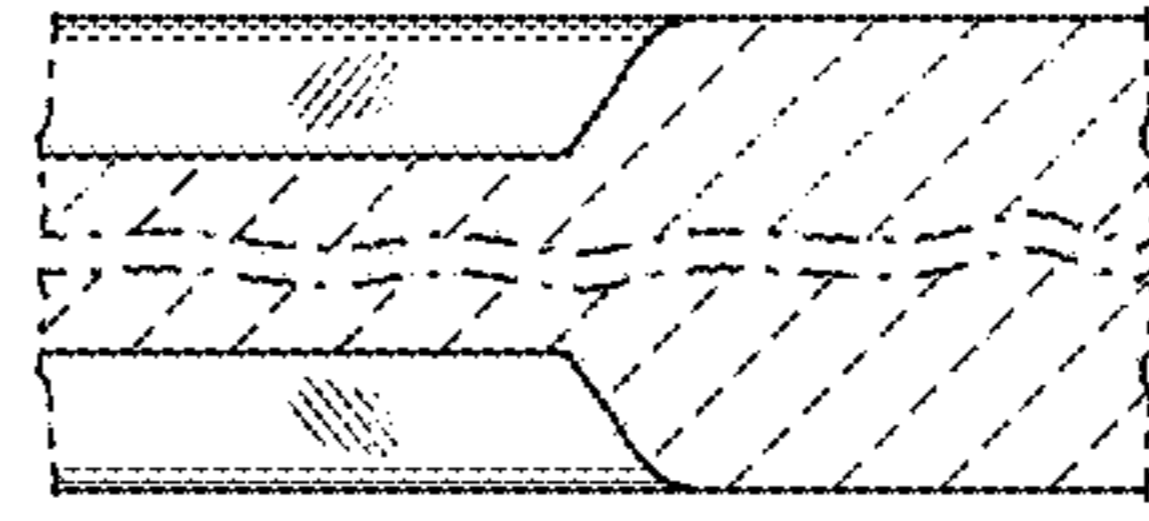

FIG. 13

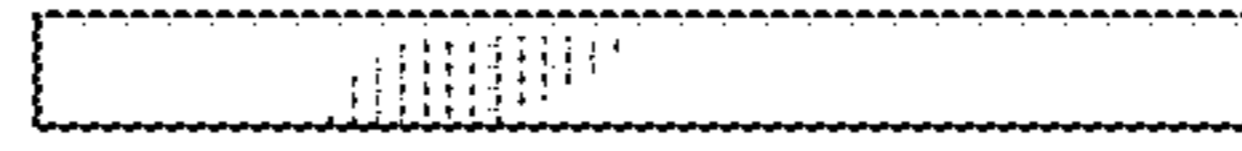

FIG. 14

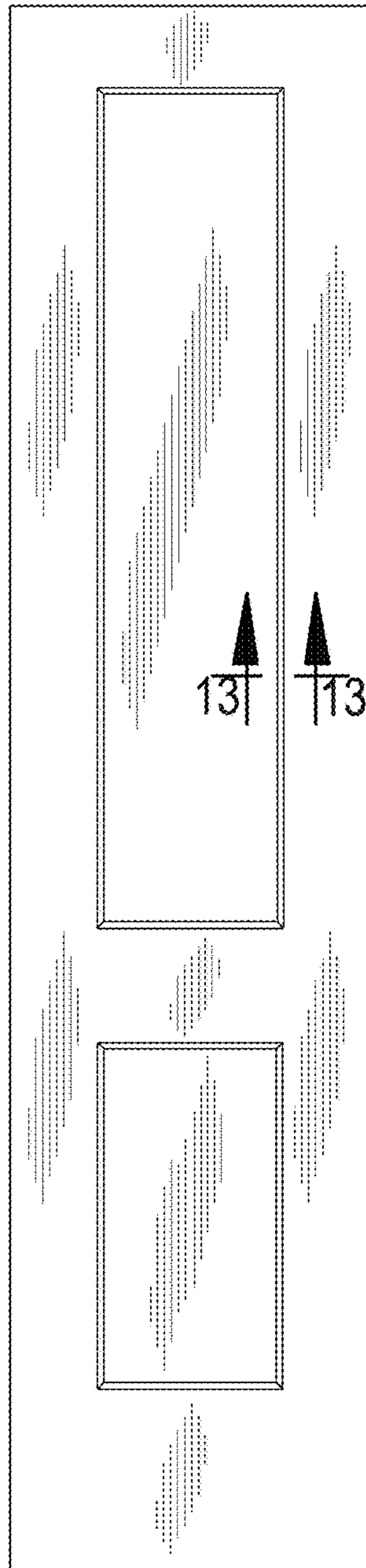

FIG. 12

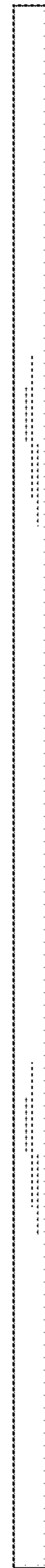

FIG. 15