



US00D844682S

(12) **United States Design Patent** (10) **Patent No.:** **US D844,682 S**
Karol et al. (45) **Date of Patent:** **** Apr. 2, 2019**

(54) **WHEEL**
(71) Applicant: **DEKA Products Limited Partnership**,
Manchester, NH (US)
(72) Inventors: **Daniel S. Karol**, Southborough, MA
(US); **Jason M. Overson**, Manchester,
NH (US); **William D. Hunt**, Chicago,
IL (US); **Jacob W. Scarpaci**,
Manchester, NH (US)

D253,641 S 12/1979 Tritchka
4,545,230 A 10/1985 Jungesjo
4,630,498 A 12/1986 Santi
5,137,500 A 8/1992 Lhotak
5,251,711 A 10/1993 Meyer
D396,436 S 7/1998 Liska
D399,222 S 10/1998 Chang
D402,995 S 12/1998 Hakamata
D402,996 S 12/1998 Watanabe
D434,351 S 11/2000 Takamori

(Continued)

(73) Assignee: **DEKA Products Limited Partnership**,
Manchester, NH (US)

FOREIGN PATENT DOCUMENTS

(**) Term: **15 Years**

EP 1669254 A1 6/2006
JP 2002021981 A 1/2002

(Continued)

(21) Appl. No.: **29/645,161**

OTHER PUBLICATIONS

(22) Filed: **Apr. 24, 2018**

#25 Sprockets—VEX Robotics, <http://www.vexrobotics.com/25-sprockets.html>, Innovation First International, Inc. © 2002-2016.

(Continued)

Related U.S. Application Data

(62) Division of application No. 29/572,423, filed on Jul.
27, 2016, now Pat. No. Des. 818,015.

Primary Examiner — Patricia A Palasik

(51) **LOC (11) Cl.** **15-09**

(74) *Attorney, Agent, or Firm* — Kathleen Chapman

(52) **U.S. Cl.**
USPC **D15/138**

(57) **CLAIM**

(58) **Field of Classification Search**
USPC D3/318; D12/211; D15/143, 148, 149;
D34/5, 10, 27

The ornamental design of a wheel, as shown and described.

CPC B62M 9/10; F16H 55/12; F16H 55/30
See application file for complete search history.

DESCRIPTION

(56) **References Cited**

FIG. 1 is a front, top, right side perspective view of the
wheel of 30 mm in size, showing our new design;
FIG. 2 is a front side elevational view thereof;
FIG. 3 is a rear side elevational view thereof;
FIG. 4 is a left side elevational view thereof;
FIG. 5 is a right side elevational view thereof;
FIG. 6 is a top plan view thereof; and,
FIG. 7 is a bottom plan view thereof.

U.S. PATENT DOCUMENTS

1,385,144 A 7/1921 Myers
2,791,911 A 5/1957 Wasko
2,811,819 A 11/1957 Heth
2,859,634 A 11/1958 Gustave
3,176,597 A 4/1965 Seaman
3,490,360 A 1/1970 Reynolds

1 Claim, 6 Drawing Sheets

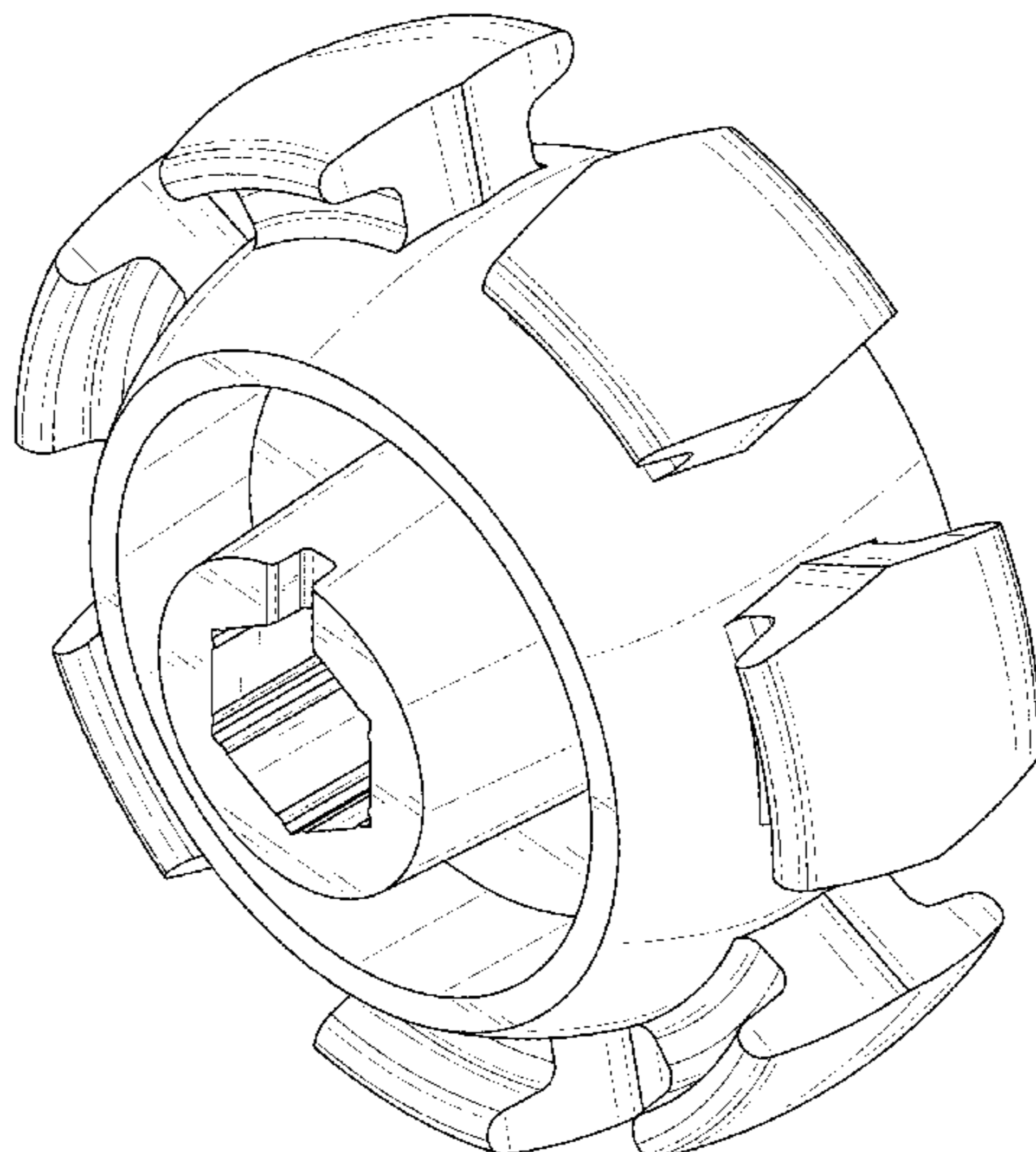

(56)

References Cited

U.S. PATENT DOCUMENTS

D435,001	S	12/2000	Takamori	
D436,561	S	1/2001	Louden	
D442,200	S	5/2001	Koch	
D443,880	S	6/2001	Iida	
6,283,076	B1	9/2001	Simpson	
D451,526	S	12/2001	Lee	
D470,861	S	2/2003	Kohno	
D470,862	S	2/2003	Kohno	
D472,843	S	4/2003	Marquez-Pickering	
D473,902	S	4/2003	Panno	
6,722,221	B2	4/2004	Maxwell	
6,910,980	B2	6/2005	Hamilton	
D527,245	S	8/2006	Kelleghan	
D561,793	S	2/2008	Kanemitsu	
7,344,463	B2	3/2008	Reiter	
D585,345	S	1/2009	Maier	
D604,346	S	11/2009	Chiang	
D611,391	S	3/2010	Bourgeois	
7,914,408	B2	3/2011	Young	
D641,611	S	7/2011	Minayoshi	
D647,118	S	10/2011	Parker	
D668,527	S	10/2012	Noumi	
D670,304	S	11/2012	Shimozaki	
D670,305	S	11/2012	Shimozaki	
D675,130	S	1/2013	Senn	
D683,099	S	5/2013	Wright	
D683,616	S *	6/2013	Noumi	D8/356
D699,267	S *	2/2014	Nelson	D15/21
D702,411	S *	4/2014	Bromm	D34/10
D728,432	S	5/2015	Lin	
9,033,835	B2	5/2015	Blank	
D750,676	S	3/2016	Brown	
D765,551	S	9/2016	Baker, Jr.	
D767,375	S *	9/2016	Nakano	D8/360
D774,987	S	12/2016	Miles	
D776,896	S	1/2017	Paitchell	
D781,345	S	3/2017	Pratley	
D787,380	S *	5/2017	Karol	D12/123
D794,690	S *	8/2017	Sewell	D15/138
D796,147	S *	8/2017	Anderson	D34/27
D800,194	S *	10/2017	Sewell	D15/148
D818,015	S *	5/2018	Karol	D15/138
2008/0176688	A1	7/2008	Sakura	
2014/0206486	A1 *	7/2014	Fuchs	F16H 55/14 474/161

FOREIGN PATENT DOCUMENTS

JP	2007309488	A	11/2007
WO	WO 2007041291	A1	4/2007

OTHER PUBLICATIONS

#35 Sprockets—VEX Robotics, <http://www.vexrobotics.com/35-sprockets.html>, Innovation First International, Inc. © 2002-2016.
 1.125" Bearing Bore Gears—VEX Robotics, <http://www.vexrobotics.com/bearing-bore-gears.html>, Innovation First International, Inc. © 2002-2016.
 Andy Mark, Gears Search—Andy Mark Inc. (<http://www.andymark.com>) <http://www.andymark.com/Gears-s/85.htm> © 2017 AndyMark, Inc. (2 pgs.).
 AndyMark Sprocket Search—AndyMark Inc. (<http://www.andymark.com>) <http://www.andymark.com/Search-s/545.htm?Search=sprocket&Submit=> © 2017 AndyMark, Inc.
 AndyMark Wheel Search—Andy Mark In. (<http://www.andymark.com>) <http://www.andymark.com/wheel-s/229.htm> © 2017 AndyMark, Inc.
 AP Table Chain Gear Assembly, posted on brunswickbowling.com, no posted date given, no production date given, [online], [site visited May 11, 2017], Available from Internet, <URL: <http://brunswickbowling.com/products/parts/gs-pinsetter/detail/table-chain-gear-assembly/>>.

Ball Shifter & Dog Gears—VEX Robotics, <http://www.vexrobotics.com/shifter-gears.html>, Innovation First International, Inc. © 2002-2016.
 Camshaft Sprocket Chain Drive, posted on dlbensinger.com, no posted date given, no production date given, [online], [site visited May 11, 2017], Available from Internet, <URL: https://www.dlbensinger.com/product_info.php?manufacturers_id=10&products_id=796>.
 Gear Base Pack—VEX Robotics, <http://www.vexrobotics.com/liq-gear-g.html>, Innovation First International, Inc. © 2002-2016.
 Gearbox Front Sprocket, posted on ebay.co.uk, posted Nov. 29, 2016, no production date given, [online], [site visited May 11, 2017], Available from Internet, <URL: <http://www.ebay.co.uk/itm/NEW-Tag-Metals-MX-Honda-CR250R-88-07-CR500R-CRF450-Gearbox-Front-Sprocket-13T-/252592369100>>.
 Kawada Machine Cut Spur Gear, posted on ebay.com, no posted date given, no production date given, [online], [site visited May 18, 2017], Available from Internet, <URL: http://www.ebay.com/itm/Kawada-Machine-Cut-Spur-Gear-64P-78T-1-10-RC-Cars-Touring-Drift-On-Road-SM6478-/142068863379?_trksid=p2385738.m2548.14275>.
 MakeBlock Wheel Search—MakeBlock Co., Ltd (<http://www.makeblock.com>) <http://www.makeblock.com/index.php?route=product/search&search=wheel> © 2013-2017 Makeblock Co., Ltd. Makeblock, Gears Search—Makeblock Co., Ltd. (<http://www.makeblock.com>) http://www.makeblock.com/index.php?route=product/category&path=69_99 ©2013-2017 Makeblock Co., Ltd. (1pg.).
 Martin Roller Chain Sprocket, posted on amazon.com, earliest review posted Nov. 18, 2012, no production date given, [online], [site visited May 11, 2017], Available from Internet, <URL: https://www.amazon.com/Martin-Roller-Sprocket-Bored-Single/product-reviews/B004JXWH8C/ref=cm_cr_getr_d_paging_btm_3?ie=UTF8&reviewerType=avp_only_reviews&sortBy=r>.
 Modern Robotics Wheel Search—Modern Robotics Inc. (<https://www.modernroboticsinc.com>) <http://www.modernroboticsinc.com/search?q=wheel> © 2017 Modern Robotics Inc.
 Modern Robotics, Gears Search—Modern Robotics, Inc. (<http://www.modernroboticsinc.com>) <http://www.modernroboticsinc.com/search?q=gear> © 2017 Modern Robotics, Inc.
 Pitsco Tetrax, Gears Search—Tetrax Robotics (<http://www.tetraxrobotics.com>) <http://www.tetraxrobotics.com/Search/gears?st=0> © 2017 Pitsco, Inc. (1 pg.).
 Robinson Racing Spur Gear, 72T; NRU, TMX RRP8572, posted on amazon.com, earliest reviewed Jan. 19, 2015, no production date given, [online], [site visited May 18, 2017], Available from Internet, <URL: https://www.amazon.com/Robinson-Racing-Steel-Spur-Gear/dp/B0006N6N7K/ref=sr_1_9?ie=UTF8&qid=1495154175&sr=8-9&keywords=spur+gear>.
 Roller chain sprockets and platewheels, posted fbchain.com, no posted date given, no production date given, [online], [site visited May 11, 2017], Available from Internet, <URL: <http://www.fbchain.com/sprockets>>.
 Servocity Robotics Wheel Search—Servocity Robotics (<https://www.servocity.com>) <https://www.servocity.com/catalogsearch/result?q=wheel> © 1999-2016 Robotzone, LLC, ServoCity® is a registered trademark of Robotzone, LLC.
 Servocity, Gears Search—Servocity (<https://www.servocity.com>) © 1999-2016 Robotzone, LLC—ServoCity® is a registered trademark of Robotzone, LLC (2 pgs.).
 SparkFun Electronics Sprocket Search—SparkFun Electronics (<https://www.sparkfun.com>) <https://www.sparkfun.com/search/results?term=sprocket> (Publication date unknown but assumed to be prior to the filing date).
 SparkFun Gears Search—SparkFun Electronics (<https://www.sparkfun.com>) <https://www.sparkfun.com/search/results?term=gears> (Publication date unknown but assumed to be prior to filing date.).
 SparkFun Wheel Search—SparkFun Electronics (<https://www.sparkfun.com>) <https://www.sparkfun.com/search/results?term=wheel> (Publication date unknown but assumed to be prior to the filing date.).

(56)

References Cited

OTHER PUBLICATIONS

Sprocket Hub Gear Guard Kit, posted on ebay.com, no posted date given, no production date given, [online], [site visited May 11, 2017], Available from Internet, <URL: <http://www.ebay.com/itm/191673594110?rmvSB=true>>.

Sprockets & Chain—VEX Robotics, <http://vexrobotics.com/sprockets-and-chain.html>, Innovation First International, Inc. © 2002-2016.

Sprockets & Chain Kit—VEX Wiki, https://www.vexrobotics.com/wiki/Sprocket_and_Chain_Kit, Innovation First International, Inc. © 2002-2016.

Tetrix Pitsco Wheel Search—Pitsco Inc. (<http://www.servocity.com>) <http://www.tetrixrobotics.com/Search/wheel?st=0> © 2017 Pitsco, Inc.

Tsubaki Sprockets, posted on frasers.com, no posted date given, no production date given [online], [site visited May 11, 2017], Available from Internet, <URL: <http://www.frasers.com/supplier/tsubaki-of-canada-ltd-16573675102/product-category/chain-sprockets-10647377260>>.

United 22mm Spline Drive Metro Sprocket, posted on acebmx.com, posted Sep. 17, 2013, no production date given, [online], [site

visited May 11, 2017], Available from Internet, <URL: <http://www.acebmx.com/sprockets-bmx-c-60/united-22m-spline-drive-metro-sprocket-p-3633.html>>.

Vex Pro Gears—VEX Robotics (<https://www.vexrobotics.com>) <https://www.vexrobotics.com/vexpro/motion/vexpro-gears> © 2002-2017, VEX Robotics, Inc. is a subsidiary of Innovation First International, Inc. (2 pages).

Vex Robotics Gears Search—Vex Robotics (<https://www.vexrobotics.com>) <https://www.vexrobotics.com/catalogsearch/result/?q=gears> ©2002-2017. VEX Robotics, Inc. is a subsidiary of Innovation First International, Inc.

Vex Robotics Sprocket Search—Vex Robotics, Inc. (<https://www.vexrobotics.com>) <https://www.vexrobotics.com/catalogsearch/result/?q=sprocket> (Publication date unknown but assumed to be prior to filing date.).

Vex Robotics Wheel Search—Vex Robotics (<https://www.vexrobotics.com>) <https://www.vexrobotics.com/catalogsearch/result/?q=wheel> © 2002-2017. VEX Robotics, Inc. is a subsidiary of Innovation First International, Inc.

* cited by examiner

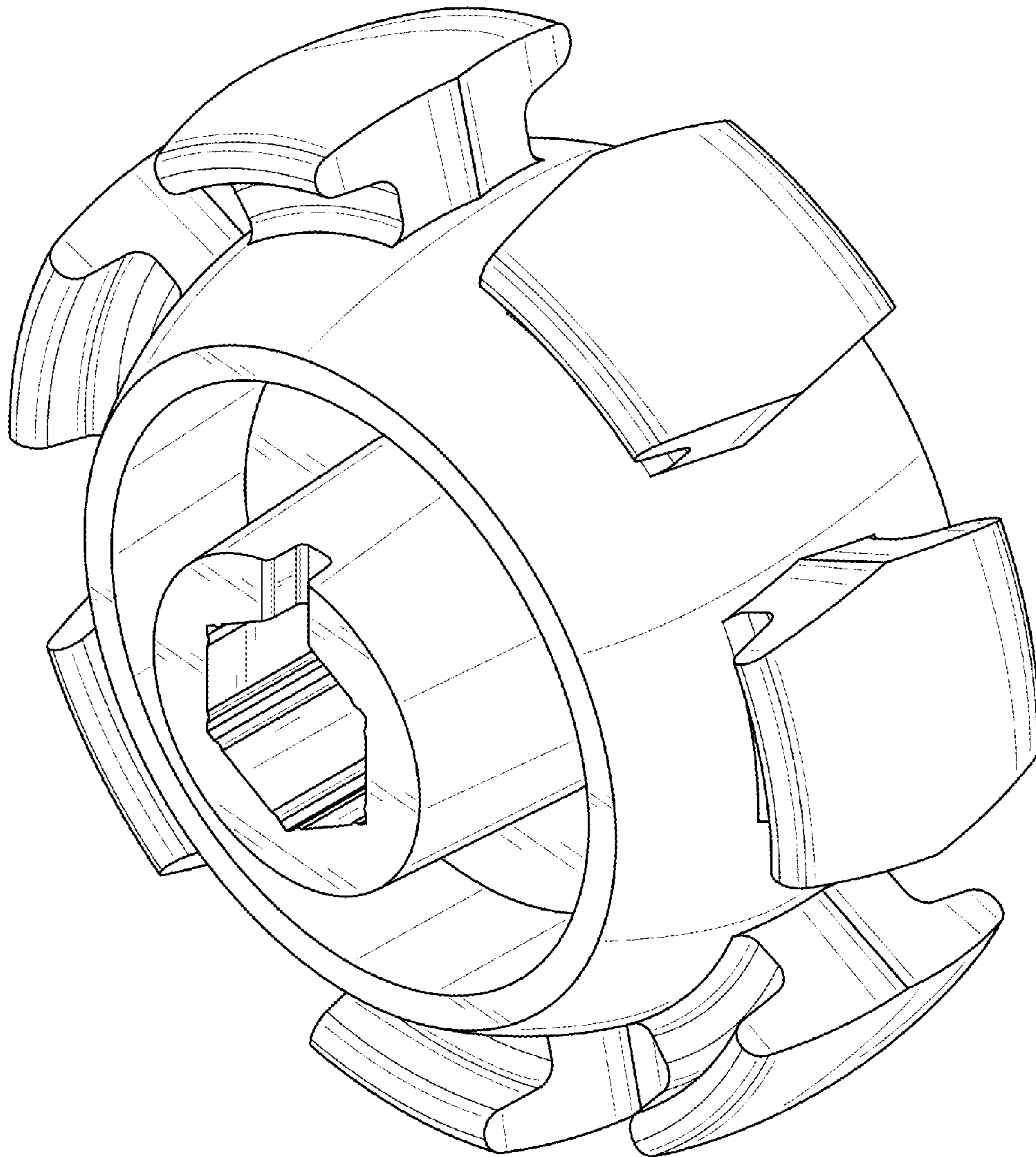

FIG. 1

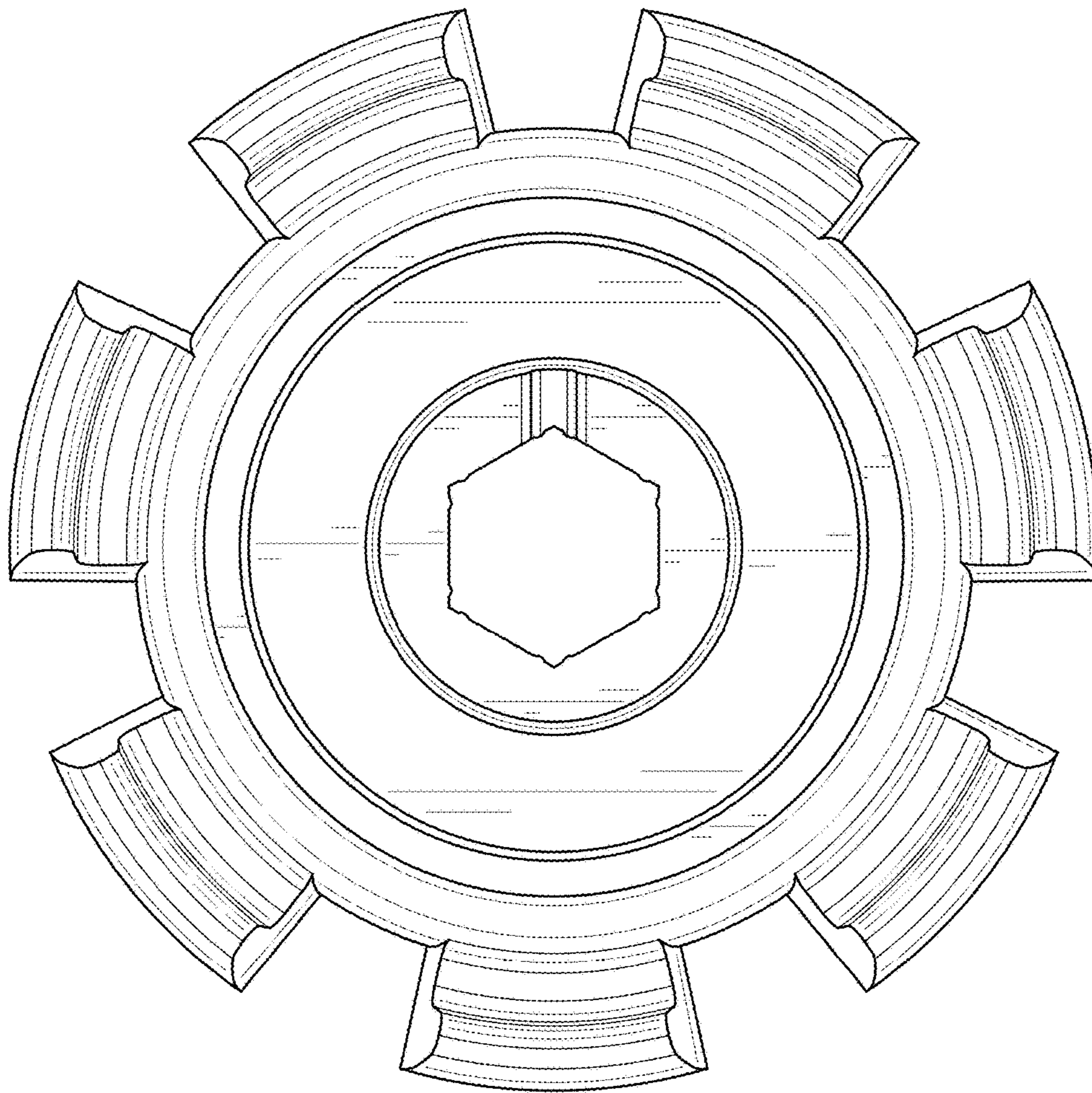

FIG. 2

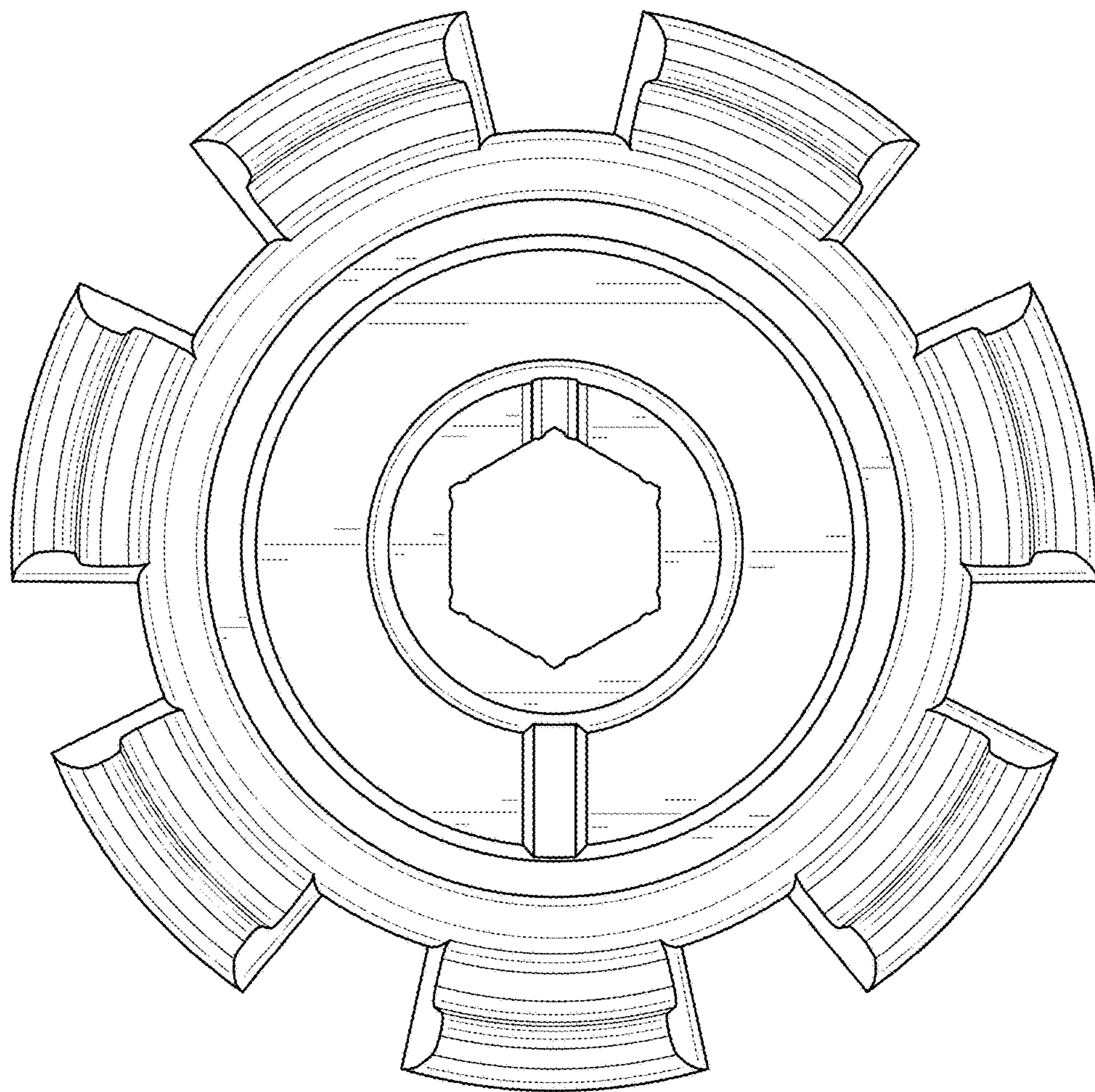

FIG. 3

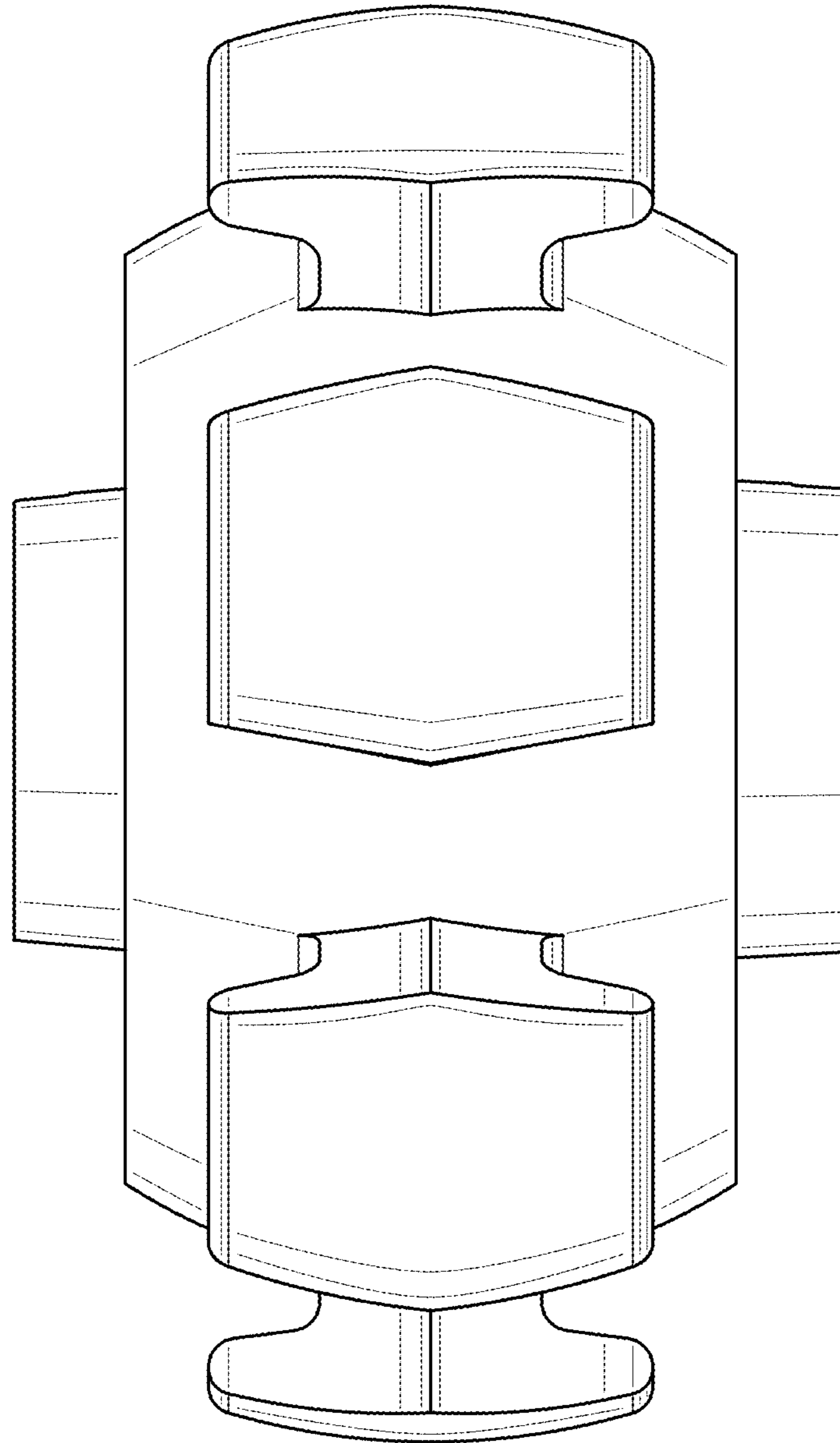

FIG. 4

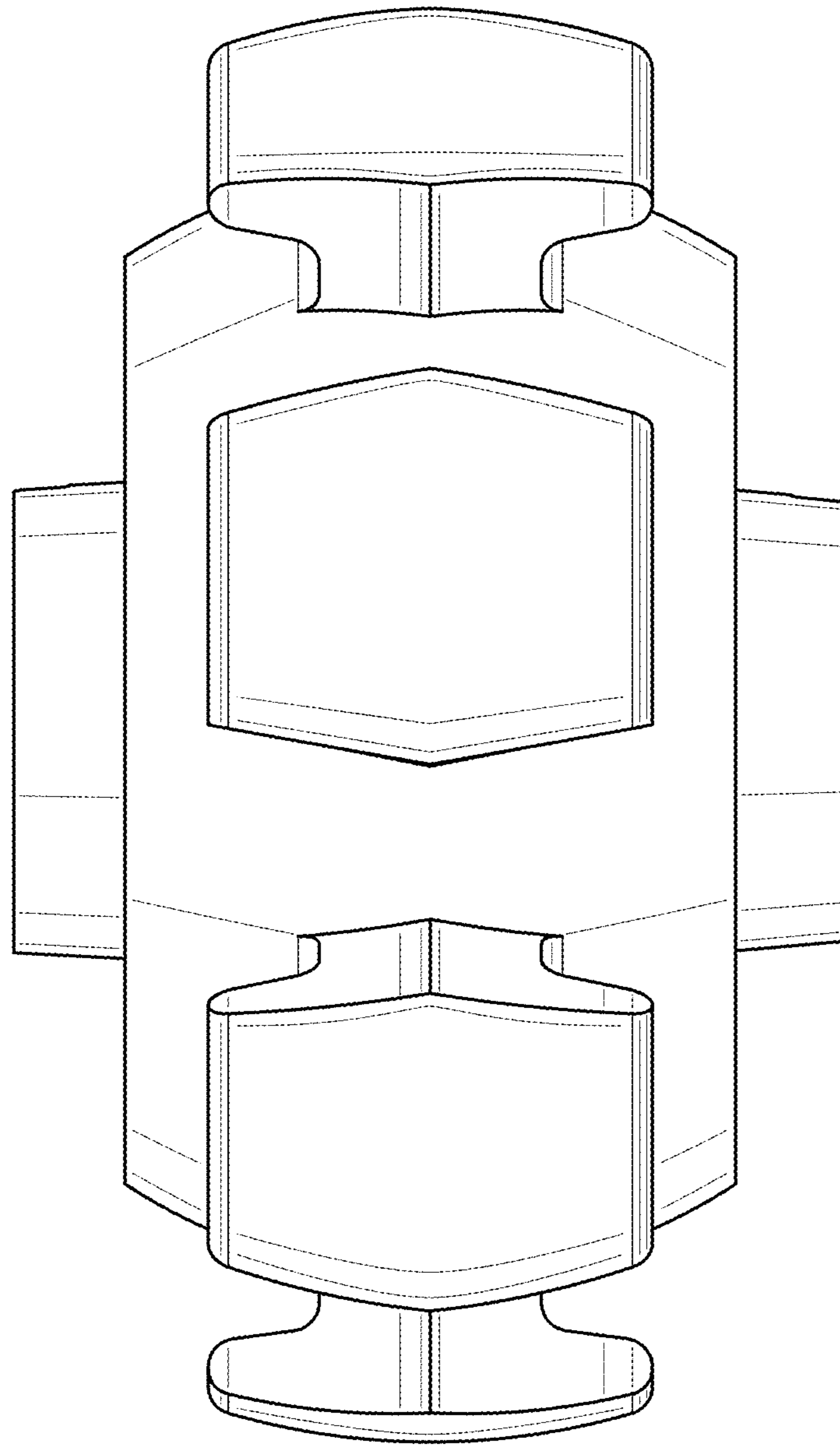

FIG. 5

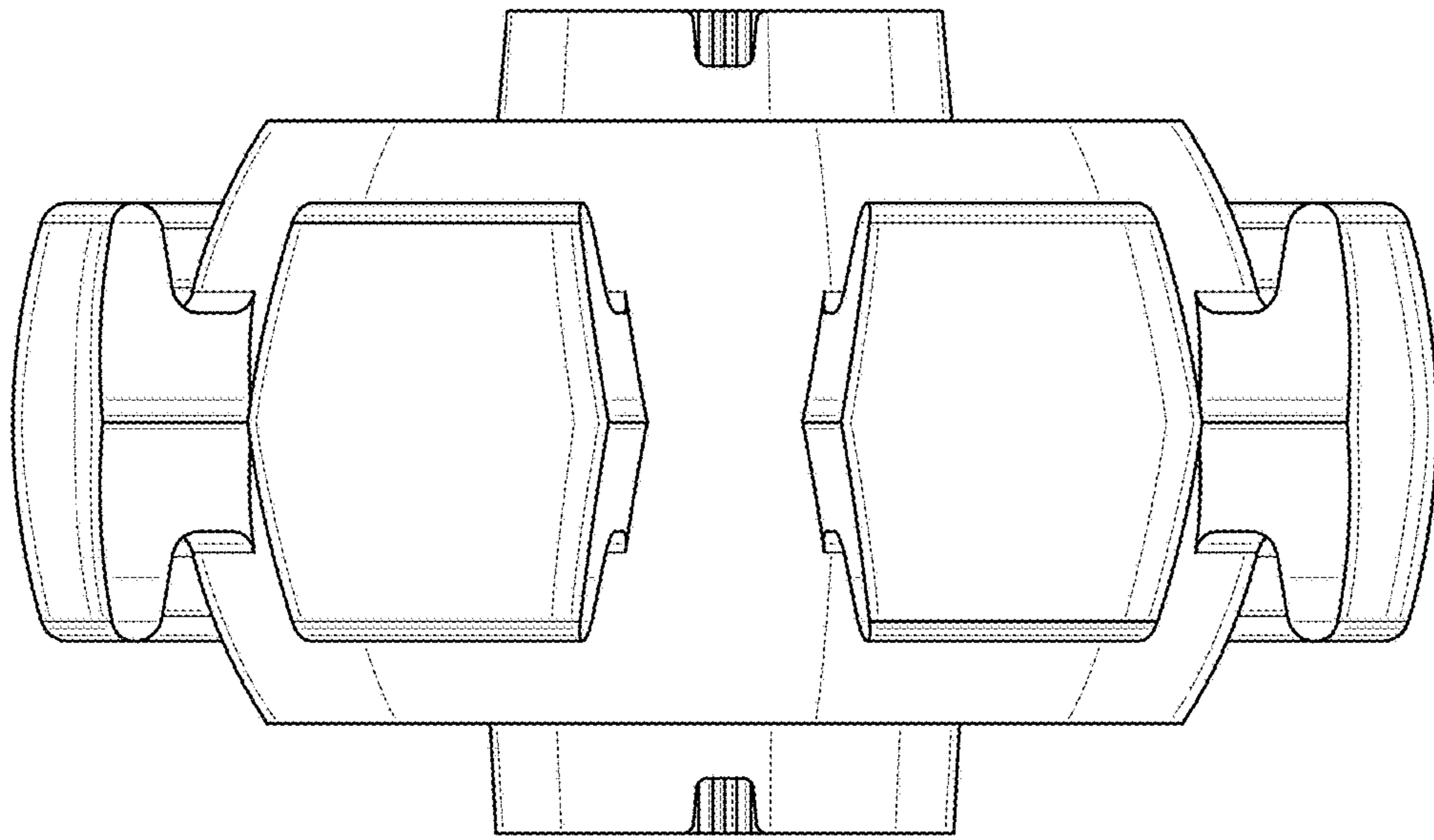

FIG. 6

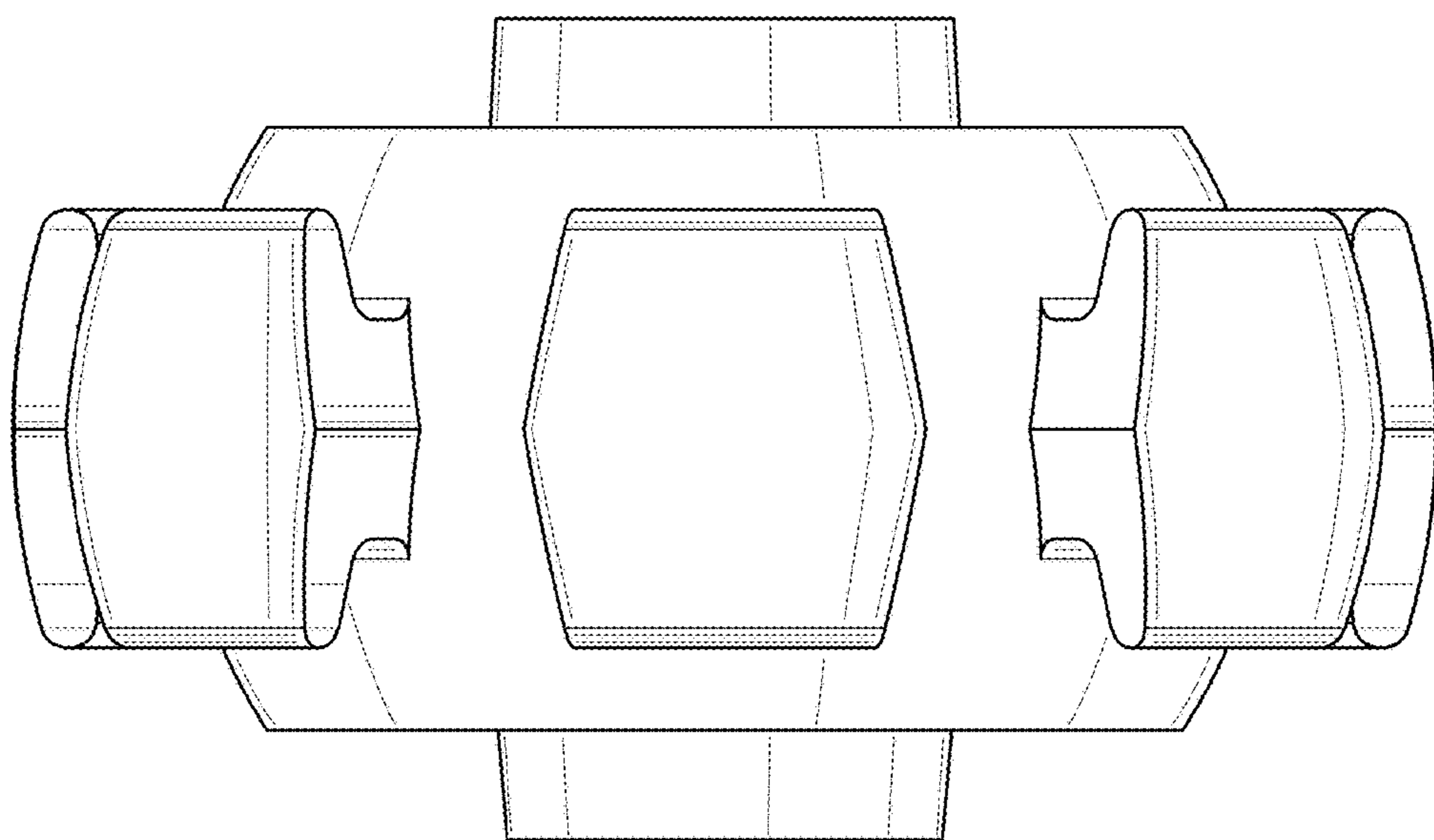

FIG. 7