



US00D844586S

(12) **United States Design Patent** (10) **Patent No.:** **US D844,586 S**
Sweet et al. (45) **Date of Patent:** **** Apr. 2, 2019**

(54) **AUDIO ASSEMBLY**

FOREIGN PATENT DOCUMENTS

(71) Applicant: **Google LLC**, Mountain View, CA (US)

CN 2449439 Y 9/2001
CN 1788523 A 6/2006

(72) Inventors: **Kenneth Sweet**, San Francisco, CA (US); **Maj Isabelle Olsson**, Sunnyvale, CA (US); **Peter Cazalet**, Los Gatos, CA (US); **Gina Reimann**, Sunnyvale, CA (US)

(Continued)

OTHER PUBLICATIONS

(73) Assignee: **Google LLC**, Mountain View, CA (US)

International Search Report and Written Opinion for Application No. PCT/US2014/043804 dated Sep. 24, 2014.

(**) Term: **15 Years**

(Continued)

Primary Examiner — Paula Allen Greene

(21) Appl. No.: **29/612,920**

(74) *Attorney, Agent, or Firm* — Lerner, David, Littenberg, Krumholz & Mentlik, LLP

(22) Filed: **Aug. 4, 2017**

(57) **CLAIM**

The ornamental design for an audio assembly, as shown and described.

(51) **LOC (11) Cl.** **14-01**

DESCRIPTION

(52) **U.S. Cl.**

USPC **D14/205**

(58) **Field of Classification Search**

USPC D14/205, 223, 218, 433, 372; 181/129, 181/130, 135; 379/430, 431; 381/380, 381/381, 370, 374, 375; 455/90.3, 575.1, 455/569.1; 345/7, 8

CPC H04R 1/10; H04R 1/1033; H04R 5/0335; H04R 5/033; H04R 1/1058; H04R 1/1041; H04R 1/1066; H04R 1/1016

See application file for complete search history.

FIG. 1 is a front perspective view of an audio assembly according to a first embodiment of our design; FIG. 2 is a front elevation view thereof; FIG. 3 is a rear elevation view thereof; FIG. 4 is a right side elevation view thereof; FIG. 5 is a left side elevation view thereof; FIG. 6 is a top elevation view thereof; FIG. 7 is a bottom elevation view thereof; FIG. 8 is a front perspective view of an audio assembly according to a second embodiment of our design; FIG. 9 is a front elevation view thereof; FIG. 10 is a rear elevation view thereof; FIG. 11 is a right side elevation view thereof; FIG. 12 is a left side elevation view thereof; FIG. 13 is a top elevation view thereof; and, FIG. 14 is a bottom elevation view thereof.

Broken lines are environmental only and form no part of the claimed design.

The portions shown in a pattern of stipple illustrate areas of contrasting appearance.

(56) **References Cited**

U.S. PATENT DOCUMENTS

1,668,890 A 5/1928 Curran et al.
1,668,910 A 5/1928 Jones
1,953,437 A 4/1934 Schier
D102,655 S 1/1937 Nicholides
2,474,135 A 6/1949 White
2,619,960 A 12/1952 Reynolds
2,910,679 A 10/1959 Baldwin

(Continued)

1 Claim, 10 Drawing Sheets

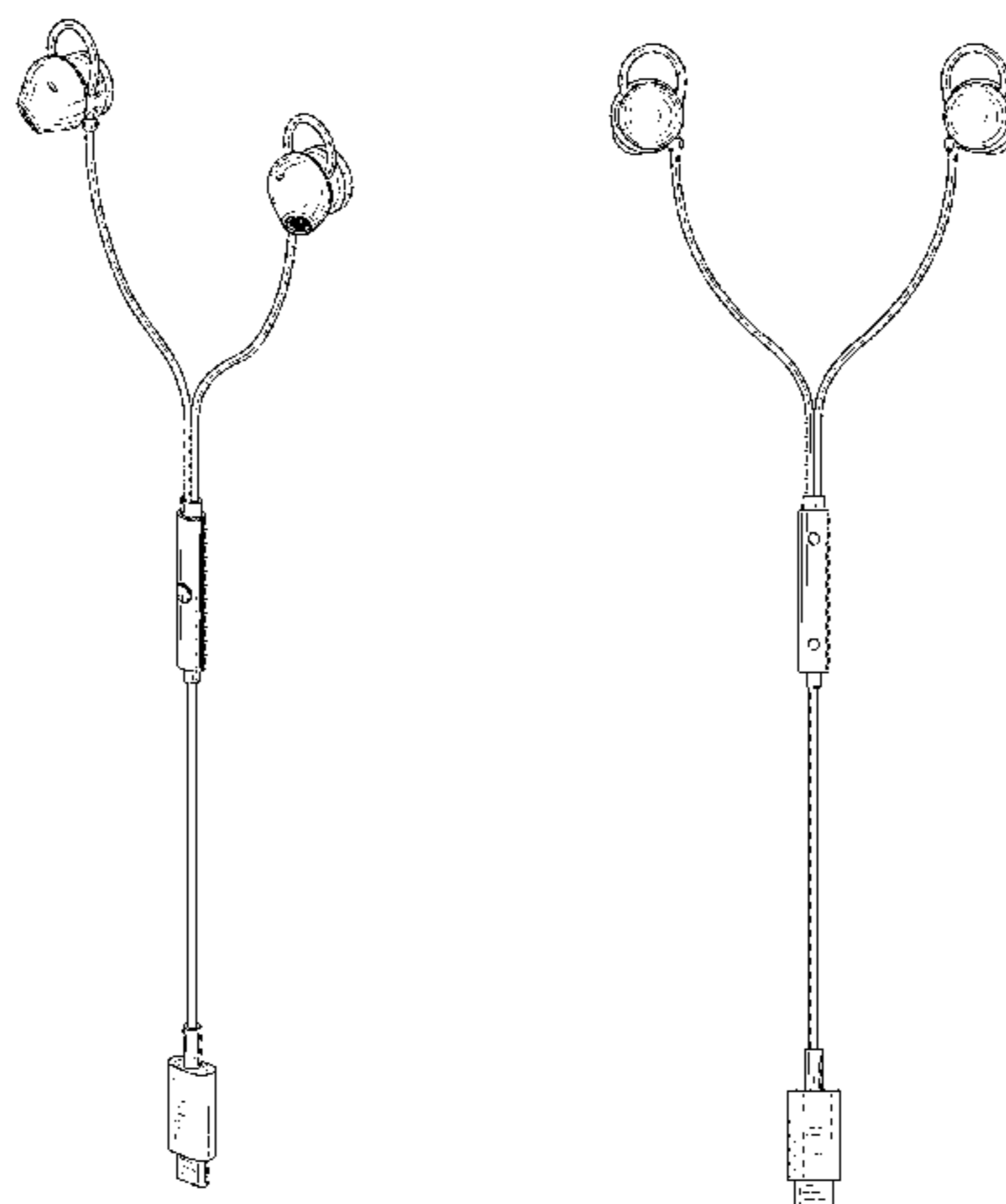

(56)

References Cited

U.S. PATENT DOCUMENTS

2,971,065 A	2/1961	Busse	
3,034,320 A	5/1962	Feibelman	
3,049,582 A *	8/1962	Shinn	H01R 4/70 174/92
3,324,253 A	6/1967	Uemura et al.	
3,440,365 A	4/1969	Bryant et al.	
3,712,409 A	1/1973	Kizakisz et al.	
3,789,164 A	1/1974	Ryder	
4,133,984 A	1/1979	Akiyama	
4,457,396 A	7/1984	James	
D280,280 S	8/1985	Pestone	
D281,033 S	10/1985	Mohri	
D287,764 S	1/1987	Topholm	
D287,765 S	1/1987	Topholm	
4,669,129 A	6/1987	Chance	
D299,344 S	1/1989	Stevens	
D318,670 S *	7/1991	Taniguchi	D14/205
5,036,681 A	8/1991	Schaerer	
5,054,079 A	10/1991	Frielingsdorf et al.	
D326,655 S *	6/1992	Iribe	D14/192
D344,524 S *	2/1994	Taniguchi	D14/205
5,345,509 A	9/1994	Hofer et al.	
5,606,743 A	2/1997	Vogt et al.	
5,654,530 A	8/1997	Sauer et al.	
5,655,026 A	8/1997	Peters et al.	
5,880,773 A	3/1999	Suzuki	
5,887,720 A	3/1999	Lin	
6,122,369 A	9/2000	Hwang et al.	
6,122,388 A	9/2000	Feldman	
D435,036 S	12/2000	Koss et al.	
D436,960 S	1/2001	Budd et al.	
D469,755 S *	2/2003	Hlas	D14/223
D470,122 S *	2/2003	Hlas	D14/205
D470,123 S *	2/2003	Hlas	D14/205
D470,833 S	2/2003	Rath et al.	
6,616,080 B1	9/2003	Edwards et al.	
D481,709 S	11/2003	Solderits	
6,690,807 B1	2/2004	Meyer	
6,729,726 B2	5/2004	Miller et al.	
6,868,164 B2	3/2005	Ito et al.	
D505,132 S	5/2005	Linville et al.	
D505,411 S	5/2005	Sakai	
6,950,531 B2	9/2005	Rickards	
6,975,644 B2	12/2005	Tordera et al.	
6,978,034 B2	12/2005	Lazzeroni et al.	
D514,551 S	2/2006	Lee et al.	
D514,552 S	2/2006	Lee et al.	
D519,108 S	4/2006	Yang	
D521,493 S	5/2006	Wai	
D521,927 S	5/2006	Franck et al.	
D529,901 S *	10/2006	Ohta	D14/223
D531,169 S	10/2006	Tokioka et al.	
7,182,820 B2	2/2007	Campbell et al.	
D539,268 S	3/2007	Suzuki	
D541,228 S	4/2007	Thursfield	
D558,735 S *	1/2008	Carr	D14/206
D560,311 S	1/2008	Li et al.	
D569,841 S *	5/2008	Chung	D14/205
D573,978 S	7/2008	Ledbetter et al.	
D578,507 S	10/2008	Ando	
D579,006 S	10/2008	Kim et al.	
D582,389 S *	12/2008	Bose	D14/205
7,461,936 B2	12/2008	Jannard	
D584,284 S	1/2009	Carr et al.	
D587,681 S	3/2009	Yanai	
D591,264 S	4/2009	Hong et al.	
7,551,748 B2	6/2009	Kamo et al.	
D596,561 S	7/2009	Chon et al.	
D599,785 S	9/2009	Matsuda et al.	
D602,004 S	10/2009	Matsuoka	
D602,064 S	10/2009	Mitsui et al.	
D603,380 S	11/2009	Hutchieson	
D604,501 S	11/2009	Lee	
D606,971 S	12/2009	Christopher et al.	
D612,595 S	3/2010	McCurdy	
D614,166 S *	4/2010	Brickstad	D14/205
D614,168 S	4/2010	Rogers et al.	
D618,211 S	6/2010	Oguro et al.	
D620,256 S	7/2010	Fujimura et al.	
D620,257 S	7/2010	Fujimura et al.	
D620,482 S *	7/2010	Chen	D14/225
D621,389 S	8/2010	Nagayama et al.	
D624,902 S	10/2010	Kolton	
D627,764 S	11/2010	Tsai et al.	
7,930,007 B2	4/2011	Andreasson	
D637,585 S	5/2011	Nagayama et al.	
D637,998 S	5/2011	Brunner et al.	
D639,282 S	6/2011	Ohuri et al.	
D641,009 S	7/2011	Olodort et al.	
D642,163 S	7/2011	Lee et al.	
D643,405 S	8/2011	Rath	
D643,414 S	8/2011	Lee et al.	
D648,217 S	11/2011	Fahey et al.	
D648,316 S	11/2011	Lee et al.	
8,073,181 B2 *	12/2011	Bakalos	H04R 3/04 381/103
D652,817 S *	1/2012	Lee	D14/205
D654,056 S *	2/2012	Hoggarth	D14/205
D654,866 S	2/2012	Rautiainen	
D658,157 S	4/2012	McManigal	
D659,991 S	5/2012	Long, Jr. et al.	
D660,290 S	5/2012	Weedon	
8,174,569 B2	5/2012	Tanijiri et al.	
8,175,315 B2 *	5/2012	Tanaka	H04R 1/1016 381/370
D662,079 S	6/2012	Fahrendorff et al.	
D663,715 S	7/2012	Glezerman et al.	
8,218,808 B2 *	7/2012	Xu	H04R 1/1033 381/370
8,229,154 B2	7/2012	Ito	
D666,581 S	9/2012	Perez	
D674,373 S	1/2013	Combs et al.	
8,345,913 B2 *	1/2013	Pang	H04R 1/1033 381/384
D678,242 S	3/2013	Von Euler	
8,406,448 B2	3/2013	Lin et al.	
D681,001 S *	4/2013	Murchison	D14/205
8,442,257 B2 *	5/2013	Aase	H01B 13/0013 381/370
8,447,062 B2 *	5/2013	Lin	H04R 1/1033 381/370
D685,750 S *	7/2013	Nakagawa	D13/168
D685,761 S *	7/2013	Fletcher	D14/205
D685,764 S *	7/2013	Coulter	D14/205
D687,410 S *	8/2013	Fletcher	D14/205
D692,408 S *	10/2013	Dugger	D14/205
D692,409 S *	10/2013	Takeo	D14/205
D693,326 S *	11/2013	Takeo	D14/205
D697,962 S	1/2014	Olsson	
D698,026 S	1/2014	Kuwata et al.	
D698,750 S *	2/2014	Yoon	D14/205
D698,760 S	2/2014	Lee et al.	
D698,762 S	2/2014	Zheng et al.	
D699,226 S	2/2014	Yoon	
D700,167 S	2/2014	Hardi	
8,655,006 B2 *	2/2014	Aase	B29C 43/203 381/370
D703,634 S *	4/2014	Han	H04R 1/1016 D14/205
8,712,087 B2	4/2014	Ozawa	
D707,206 S	6/2014	Akana et al.	
8,755,555 B2	6/2014	Dougherty et al.	
8,776,801 B2	7/2014	McIntosh	
D710,335 S	8/2014	Yang	
D711,356 S	8/2014	Yang	
D713,384 S	9/2014	McNamara	
D715,777 S	10/2014	Huang et al.	
D717,767 S	11/2014	Mistry et al.	
D718,273 S *	11/2014	Harata	D14/205
D718,286 S	11/2014	Yang	
8,891,798 B1	11/2014	Laffon de Mazieres et al.	
D718,745 S	12/2014	Thompson et al.	
D719,131 S	12/2014	Toelle et al.	

(56)

References Cited

U.S. PATENT DOCUMENTS

D719,132 S * 12/2014 Toelle D14/205
 D719,551 S 12/2014 Yang
 8,908,899 B1 * 12/2014 Yang H04R 1/1033
 381/370
 D727,279 S * 4/2015 Schaal D14/205
 D727,871 S * 4/2015 Orbach D14/205
 9,031,264 B2 * 5/2015 Yang H04R 1/1033
 381/189
 D731,456 S * 6/2015 Dahlberg D14/205
 D731,793 S 6/2015 Houghton et al.
 D732,511 S 6/2015 Masters
 D736,185 S 8/2015 Yaegashi et al.
 D736,251 S 8/2015 Kim
 D737,251 S 8/2015 Thompson et al.
 D740,653 S 10/2015 Akana et al.
 D740,692 S 10/2015 Christie et al.
 D742,070 S 10/2015 Park
 D742,355 S * 11/2015 Toelle D14/205
 D742,356 S * 11/2015 Toelle D14/205
 D743,370 S * 11/2015 Toelle D14/205
 D743,932 S * 11/2015 Toelle D14/205
 D744,855 S 12/2015 Akana et al.
 D746,792 S 1/2016 Kim
 9,241,209 B2 1/2016 Toelle et al.
 D774,760 S 12/2016 Martinetti
 D776,083 S * 1/2017 Lee D14/205
 D777,100 S 1/2017 Price
 D777,710 S 1/2017 Palmborg et al.
 D780,157 S * 2/2017 Ugglä D14/205
 D781,269 S 3/2017 Choe et al.
 D781,821 S * 3/2017 Petersen D14/205
 D785,594 S * 5/2017 Zaihui D14/205
 D796,475 S * 9/2017 Wang D14/205
 9,924,010 B2 3/2018 Watson et al.
 9,980,032 B2 * 5/2018 Yajima H04R 1/1033
 D822,636 S * 7/2018 Liu D14/205
 2004/0113867 A1 6/2004 Tomine et al.
 2004/0125977 A1 7/2004 Hong et al.
 2004/0204177 A1 10/2004 Pon
 2006/0008106 A1 1/2006 Harper
 2006/0203998 A1 9/2006 Ben-Arie
 2006/0281502 A1 12/2006 Chang et al.
 2007/0064967 A1 3/2007 Feeley et al.
 2007/0098201 A1 5/2007 Chen
 2007/0201000 A1 8/2007 Jackson et al.
 2007/0272686 A1 11/2007 Yu
 2008/0101633 A1 5/2008 Ledbetter et al.
 2008/0106693 A1 5/2008 Wang
 2008/0123893 A1 5/2008 Lee
 2008/0159579 A1 7/2008 Park
 2008/0317274 A1 12/2008 Kim
 2009/0033574 A1 2/2009 Hung
 2009/0268935 A1 10/2009 Dillinger
 2009/0304220 A1 12/2009 Fujikura et al.
 2009/0323975 A1 * 12/2009 Groesch H04R 1/1091
 381/71.1
 2010/0045928 A1 2/2010 Levy
 2010/0104126 A1 * 4/2010 Greene H01B 7/225
 381/384
 2011/0012814 A1 1/2011 Tanaka
 2011/0044487 A1 * 2/2011 Nault H04R 1/1033
 381/380
 2011/0216932 A1 9/2011 Wu

2011/0249856 A1 10/2011 Takei
 2011/0255723 A1 10/2011 Obradovic et al.
 2012/0020501 A1 1/2012 Lee
 2012/0087510 A1 4/2012 Sampimon et al.
 2013/0077815 A1 * 3/2013 Stephenson H04R 1/1033
 381/370
 2013/0127980 A1 5/2013 Haddick et al.
 2013/0272560 A1 10/2013 Dougherty et al.
 2013/0315431 A1 11/2013 Grinker et al.
 2014/0079275 A1 3/2014 Minarik et al.
 2014/0138150 A1 * 5/2014 Huang H04R 1/1033
 174/71 R
 2014/0140562 A1 5/2014 Huang
 2015/0023542 A1 1/2015 Shimizu
 2016/0037248 A1 * 2/2016 Cheng H04R 1/105
 381/74
 2016/0142808 A1 * 5/2016 Monahan H04R 1/105
 381/384
 2017/0094389 A1 3/2017 Saulsbury et al.
 2017/0311105 A1 10/2017 Hariharan et al.

FOREIGN PATENT DOCUMENTS

CN 1893731 A 1/2007
 CN 102918443 A 2/2013
 CN 303113723 2/2015
 CN 303691269 S 6/2016
 CN 303815854 S 8/2016
 JP 2005318112 A 11/2005
 JP 2007013873 A 1/2007
 JP 1509978 S 10/2017
 JP 1509979 S 10/2017
 JP 1516490 S 1/2018
 JP 1516491 S 1/2018
 WO 2011077160 A1 6/2011

OTHER PUBLICATIONS

Notification of the First Office Action for Chinese Patent Application No. 201480036676.4, dated Oct. 8, 2016.
 Earin, "The World's Smallest Wireless Earbuds", [retrieved on Jul. 24, 2015]. Retrieved from the Internet: <URL: <<http://www.earin.com/>>> (undated) 1 page. Product publicly available prior to Jun. 29, 2015.
 Nokia Luna Bluetooth Headset With Wireless Charging BH-220p (Cyan). [retrieved on Jul. 24, 2015]. Retrieved from the Internet: <URL: <<http://shopping.indiatimes.com/mobiles/bluetooth-headset/nokia-luna-bluetooth-headset-with-wireless-charging-bh-220p-cyan-/10011/p>> B1420619 (undated) 1 page. Product publicly available prior to Jun. 25, 2015.
 Notice of Allowance for Japanese Design Patent Application No. 2017-027181, dated Aug. 21, 2018. 3 pages.
 Notice of Allowance for Japanese Design Patent Application No. 2017-027182, dated Aug. 21, 2018. 3 pages.
 Notice of Allowance for Japanese Design Patent Application No. 2017-027492, dated Aug. 17, 2018.
 Wanstonic Electronics Ltd. ER-III. High-Res Audio Earphone. p. 6, cited in Notice of Allowance for Japanese Design Patent Application No. 2017-027492, dated Aug. 17, 2018.

* cited by examiner

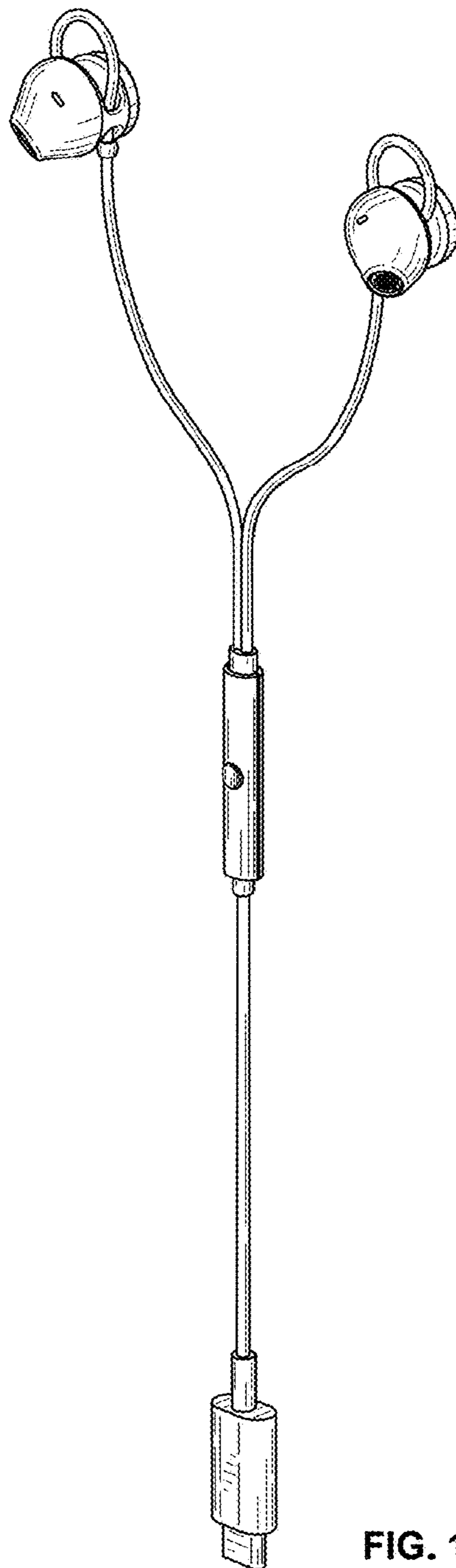

FIG. 1

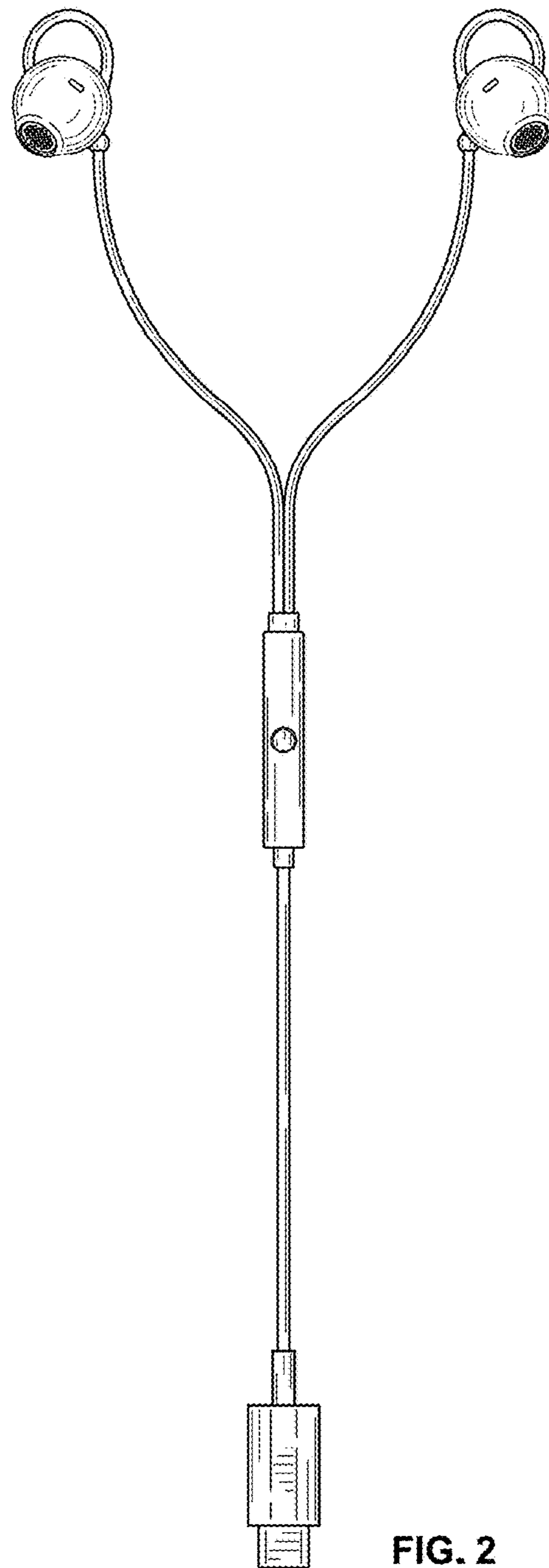

FIG. 2

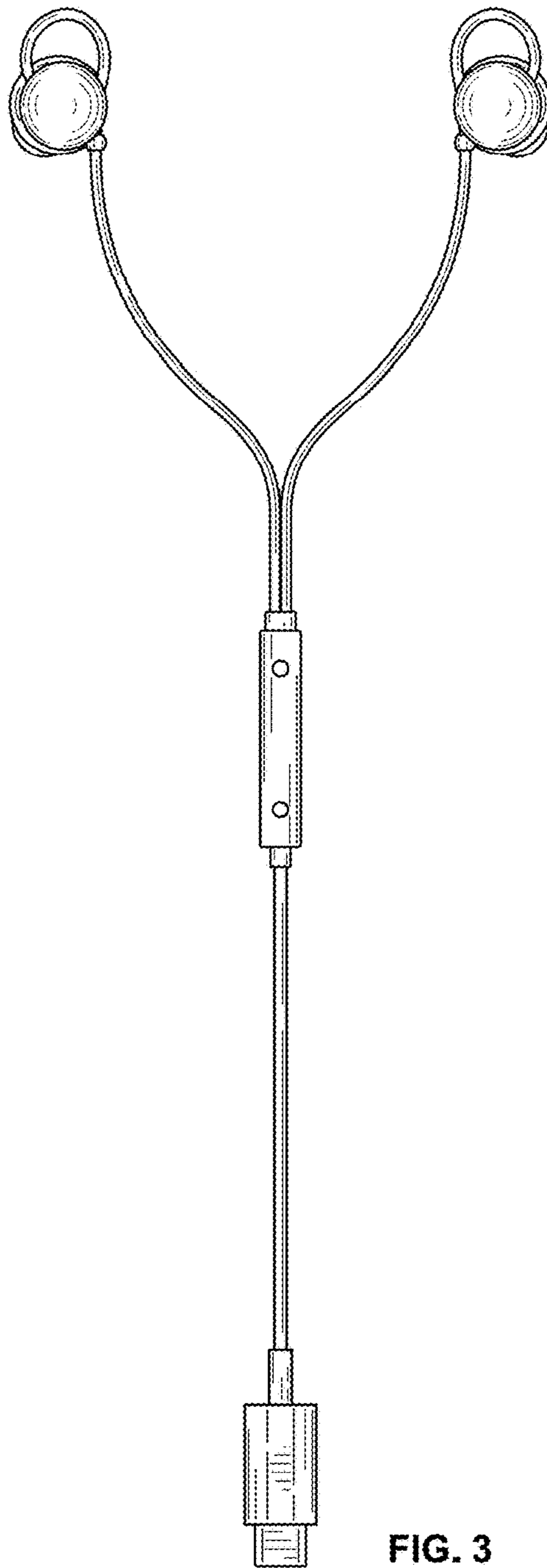

FIG. 3

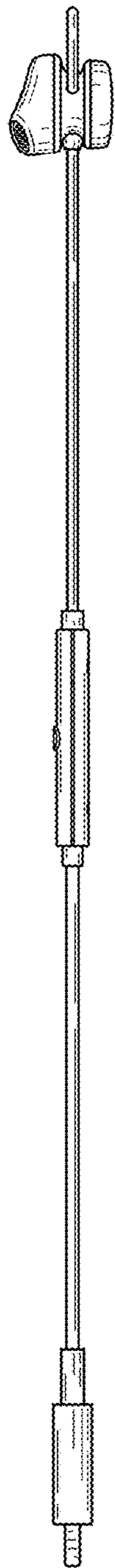

FIG. 4

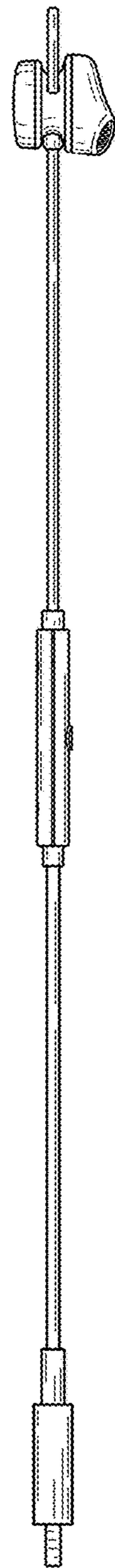

FIG. 5

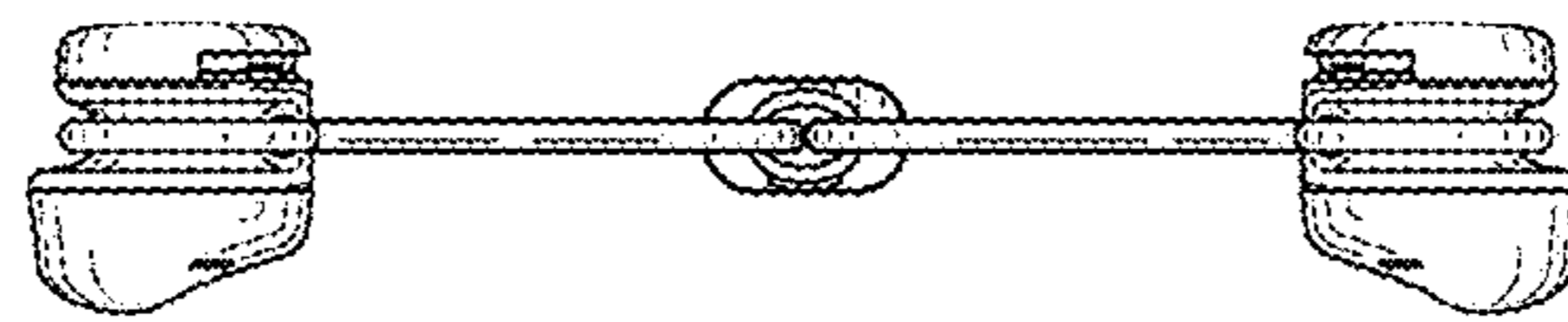

FIG. 6

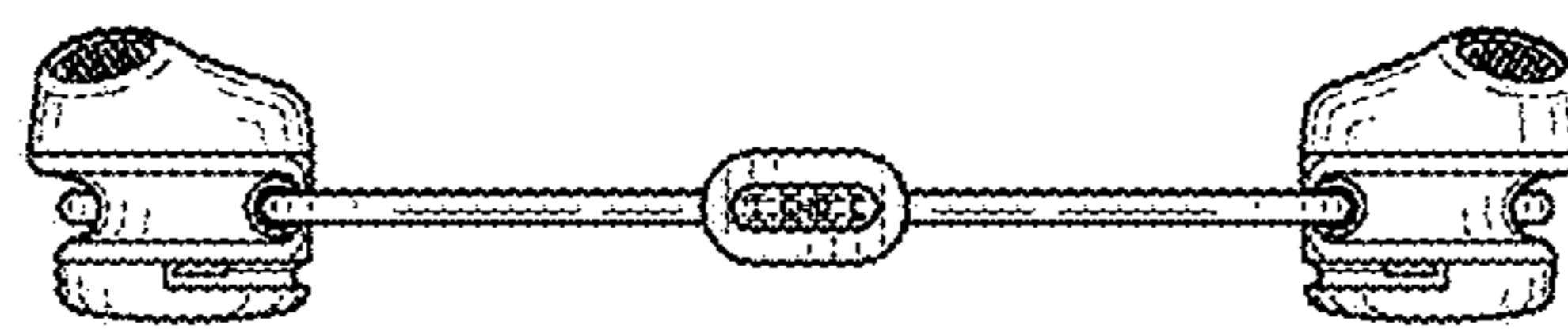

FIG. 7

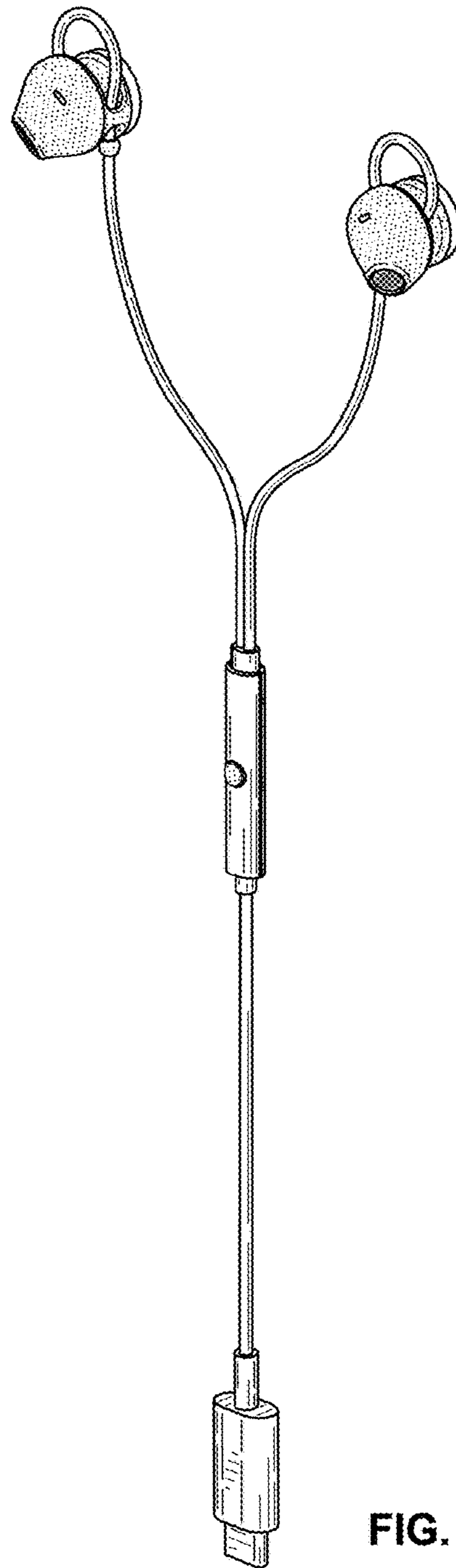

FIG. 8

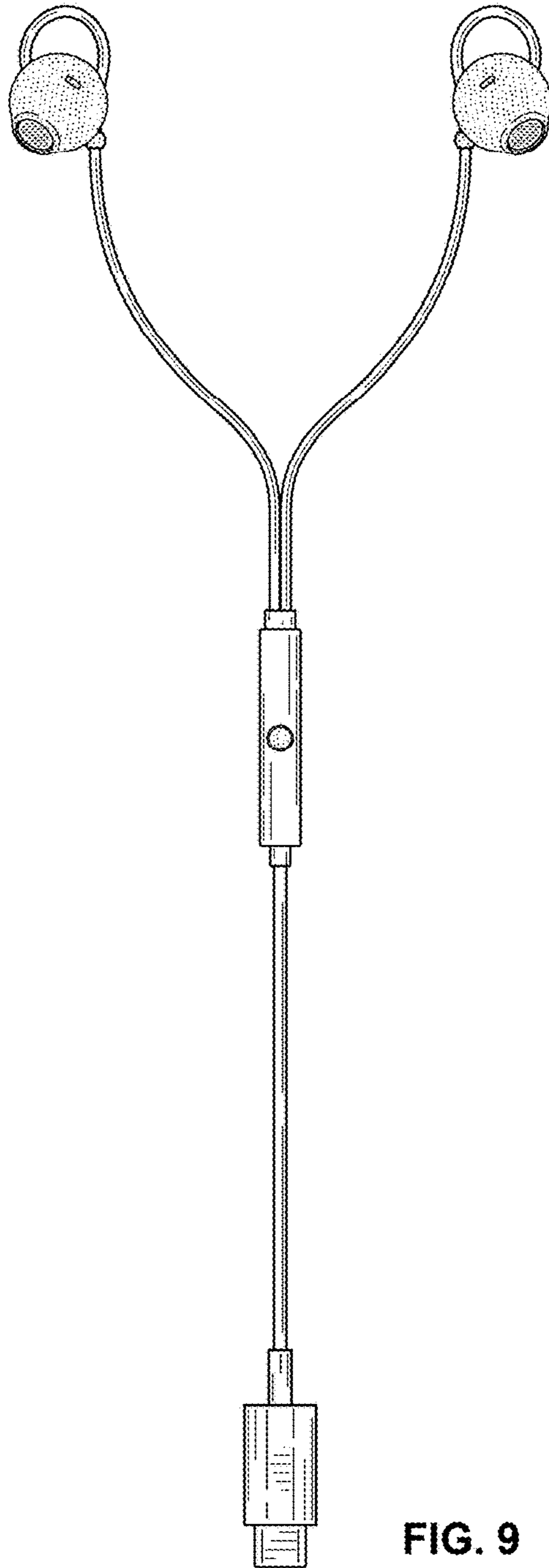

FIG. 9

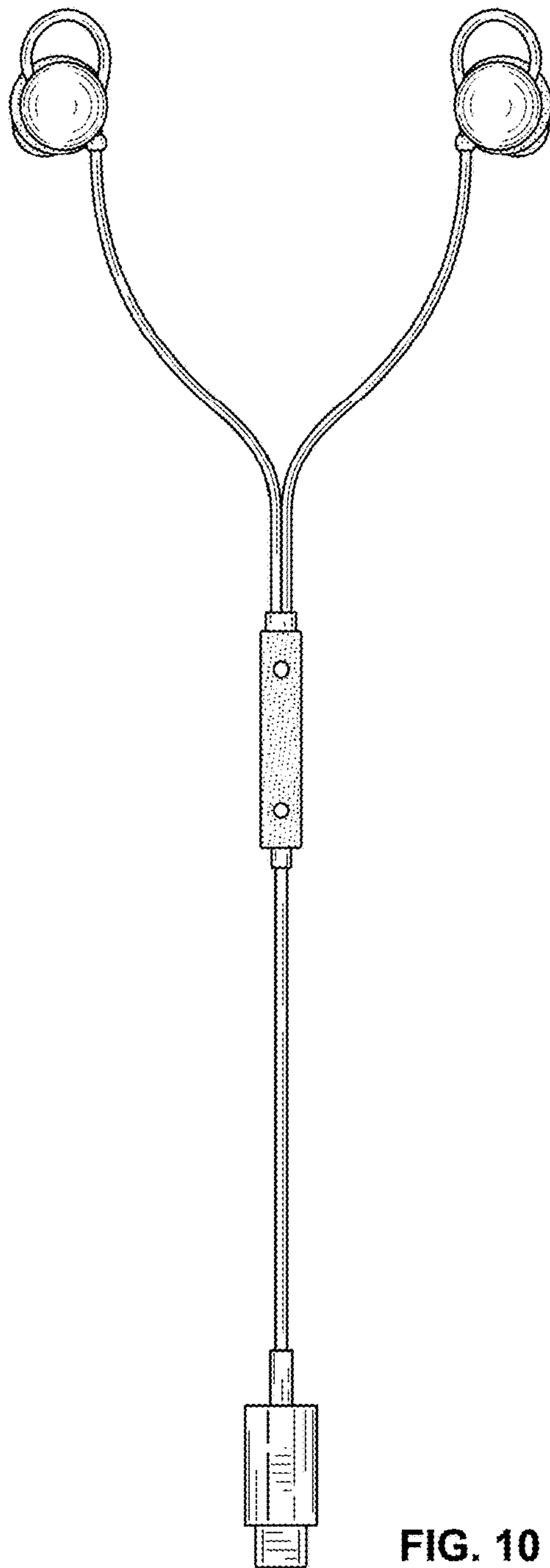

FIG. 10

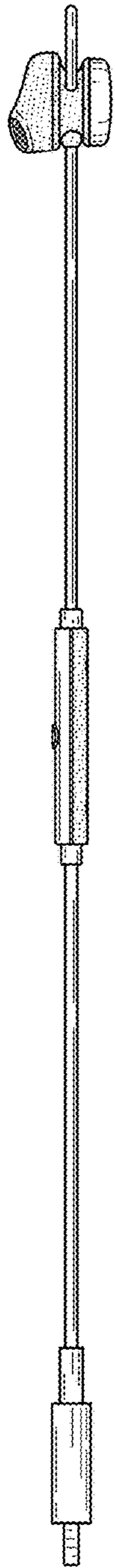

FIG. 11

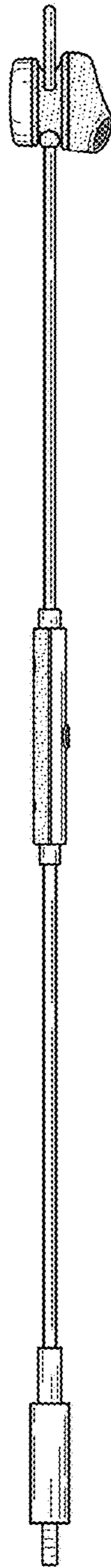

FIG. 12

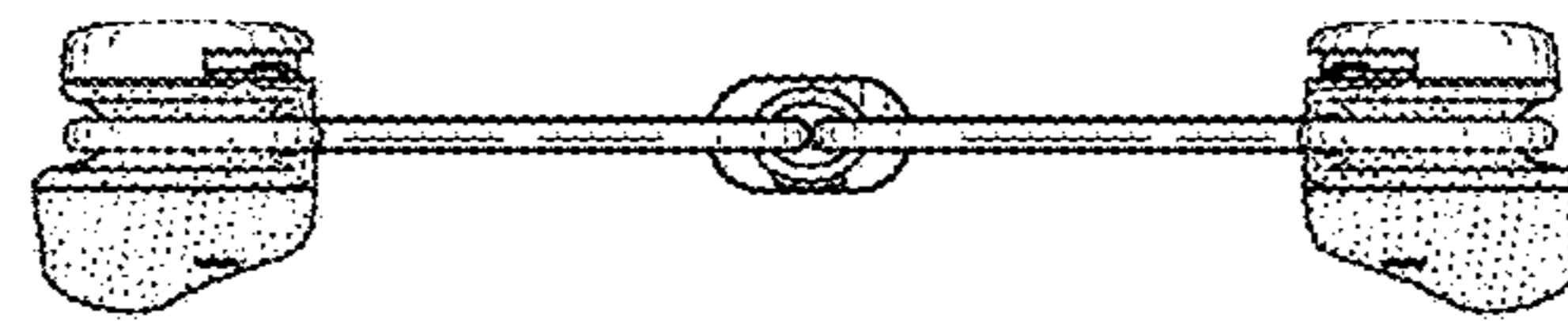

FIG. 13

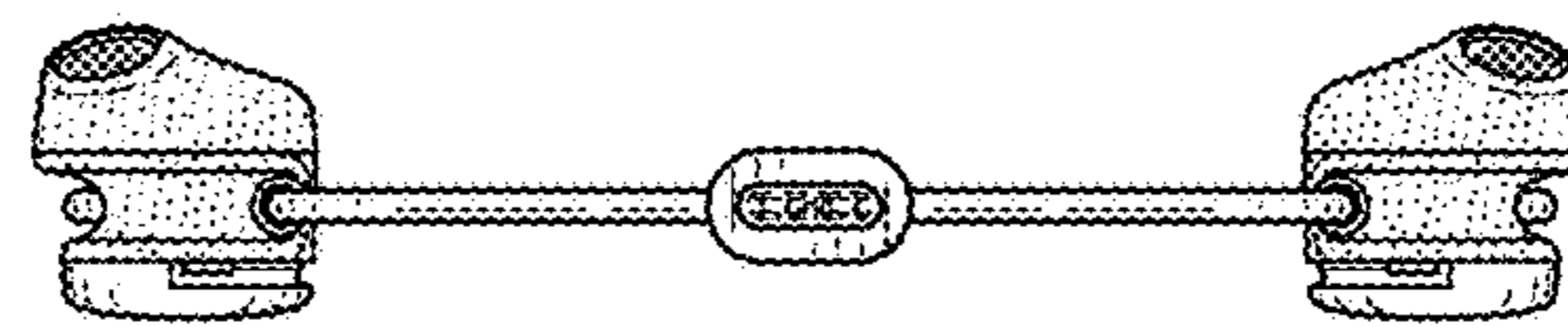

FIG. 14