



US00D844531S

(12) **United States Design Patent**
Luo

(10) **Patent No.:** **US D844,531 S**

(45) **Date of Patent:** **** Apr. 2, 2019**

(54) **VEHICLE WHEEL**

(71) Applicant: **JAT Wheels, Inc.**, Alhambra, CA (US)

(72) Inventor: **Tom Luo**, Alhambra, CA (US)

(**) Term: **15 Years**

(21) Appl. No.: **29/618,734**

(22) Filed: **Sep. 22, 2017**

(51) **LOC (11) Cl.** **12-16**

(52) **U.S. Cl.**
USPC **D12/211**

(58) **Field of Classification Search**
USPC D12/204–213
CPC B60B 7/00; B60B 7/02; B60B 7/04; B60B 7/01; B60B 7/06; B60B 3/02; B60B 3/04; B60B 3/06; B60B 3/10; B60B 1/00; B60B 1/08; B60B 1/10; B60B 1/12
See application file for complete search history.

(56) **References Cited**

U.S. PATENT DOCUMENTS

D417,427 S	*	12/1999	Brown	D12/211
D496,320 S	*	9/2004	Cheng	D12/211
D542,727 S	*	5/2007	Manfredini	D12/211
D621,771 S	*	8/2010	Truebsbach	D12/211
D625,245 S	*	10/2010	Hans	D12/211
D633,028 S	*	2/2011	Kim	D12/211
D695,193 S	*	12/2013	Kong	D12/211
D702,172 S	*	4/2014	Chung	D12/211
D704,124 S	*	5/2014	Hale, Jr.	D12/211
D706,197 S	*	6/2014	Chung	D12/211
D709,019 S	*	7/2014	Hale, Jr.	D12/211
D717,224 S	*	11/2014	Kim	D12/211
D721,630 S	*	1/2015	McLeod	D12/211
D726,630 S	*	4/2015	Kong	D12/211
D727,829 S	*	4/2015	Chung	D12/211

D765,007 S	*	8/2016	Chung	D12/211
D784,896 S	*	4/2017	Tovey	D12/211
D787,413 S	*	5/2017	Alfonso	D12/211
D787,415 S	*	5/2017	Juergens	D12/211
D790,427 S	*	6/2017	Palana	D12/211
D792,315 S	*	7/2017	Mielke	D12/211
D803,130 S	*	11/2017	Taylor	D12/209
D806,631 S	*	1/2018	Sempek	D12/211
D831,557 S	*	10/2018	Hodges	D12/209

* cited by examiner

Primary Examiner — Stacia A Cadmus

(74) *Attorney, Agent, or Firm* — Tommy SF Wang; Wang IP Law Group, P.C.

(57) **CLAIM**

The ornamental design for a vehicle wheel, as shown and described.

DESCRIPTION

FIG. 1 is a perspective view of a vehicle wheel showing my new design;
 FIG. 2 is a front view thereof;
 FIG. 3 is a rear view thereof;
 FIG. 4 is a left side view thereof;
 FIG. 5 is a right side view thereof;
 FIG. 6 is a top view thereof;
 FIG. 7 is a bottom view thereof; and
 FIG. 8 is a cross-sectional view thereof taken along the line 8-8 of FIG. 2; and,
 FIG. 9 is another front view thereof.
 The broken line of screws in FIGS. 1-2 and 8-9 illustrates unclaimed environment and forms no part of the claimed design. The broken line portions of the vehicle wheel in FIGS. 1-3, 5 and 7-9 represent unclaimed portions of the claimed design and form no part thereof.

1 Claim, 8 Drawing Sheets

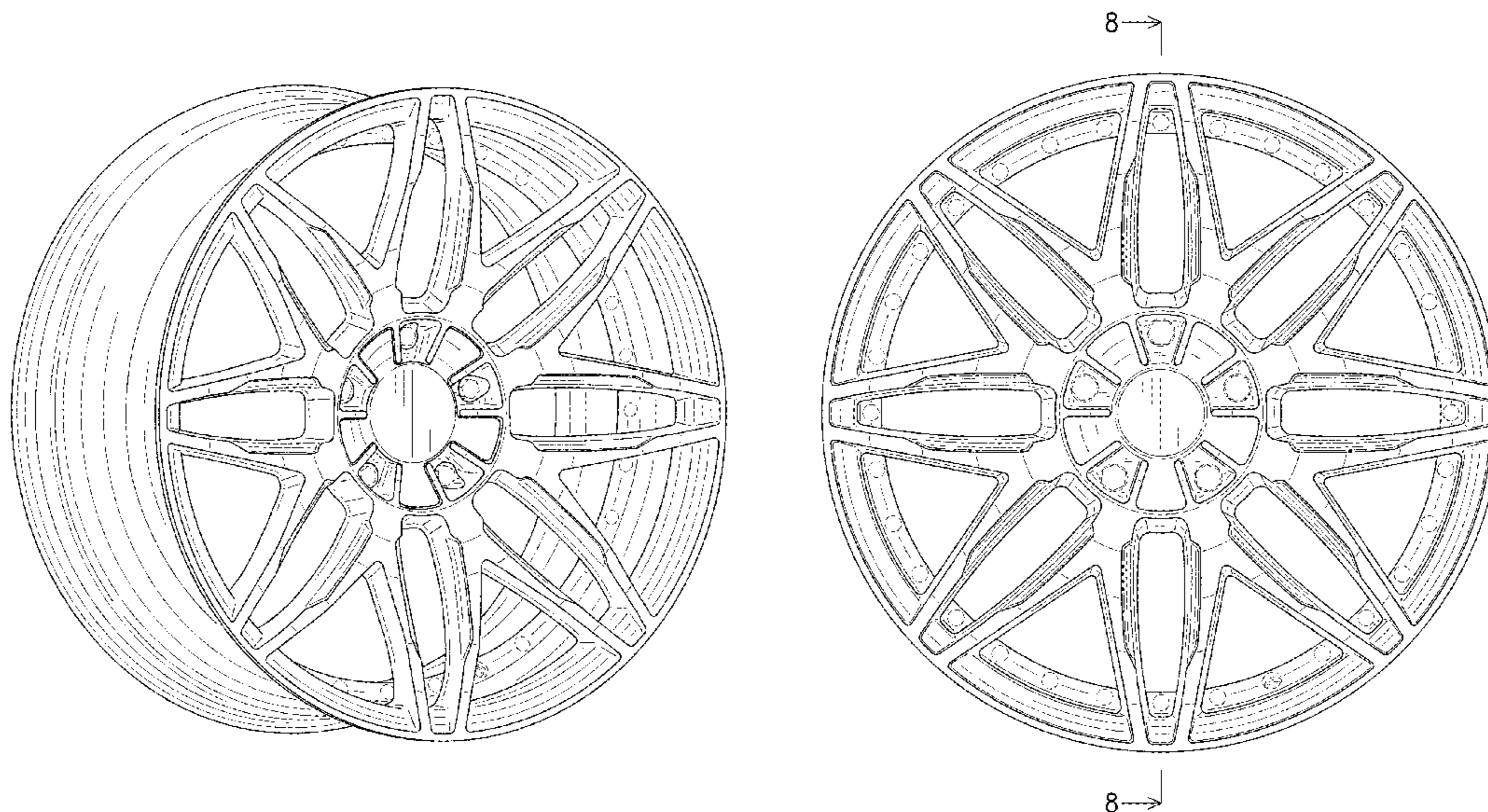

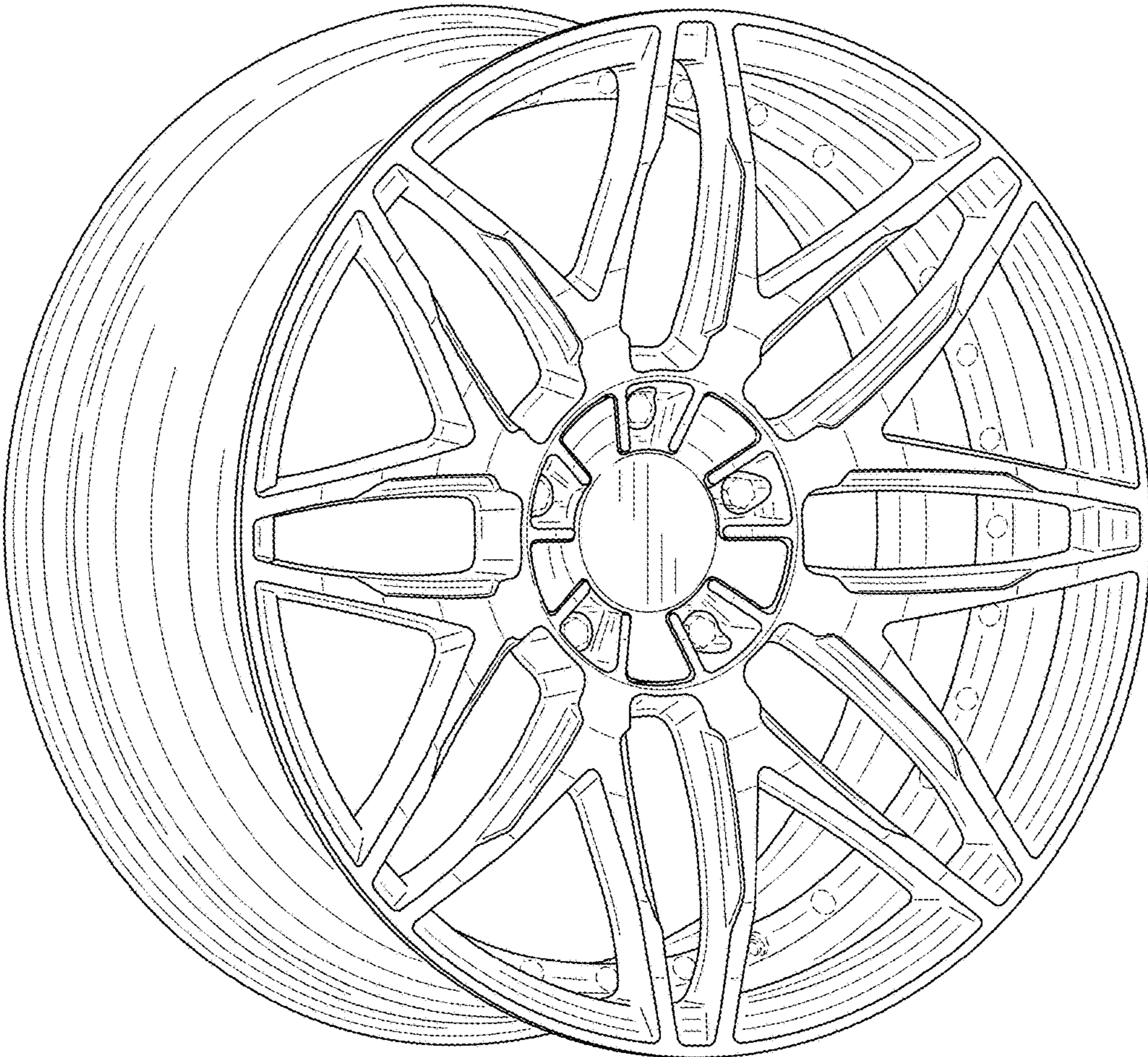

FIG. 1

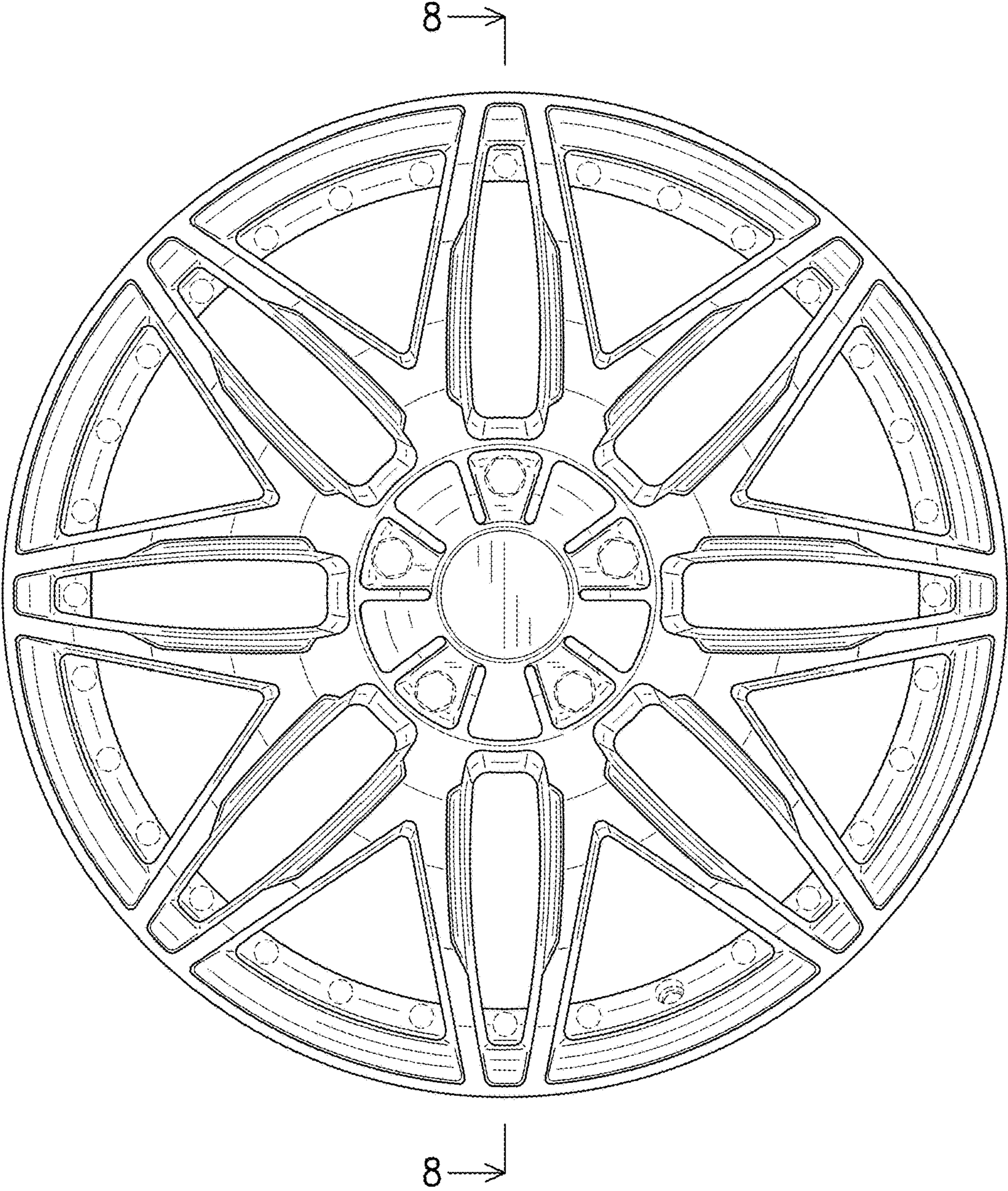

FIG. 2

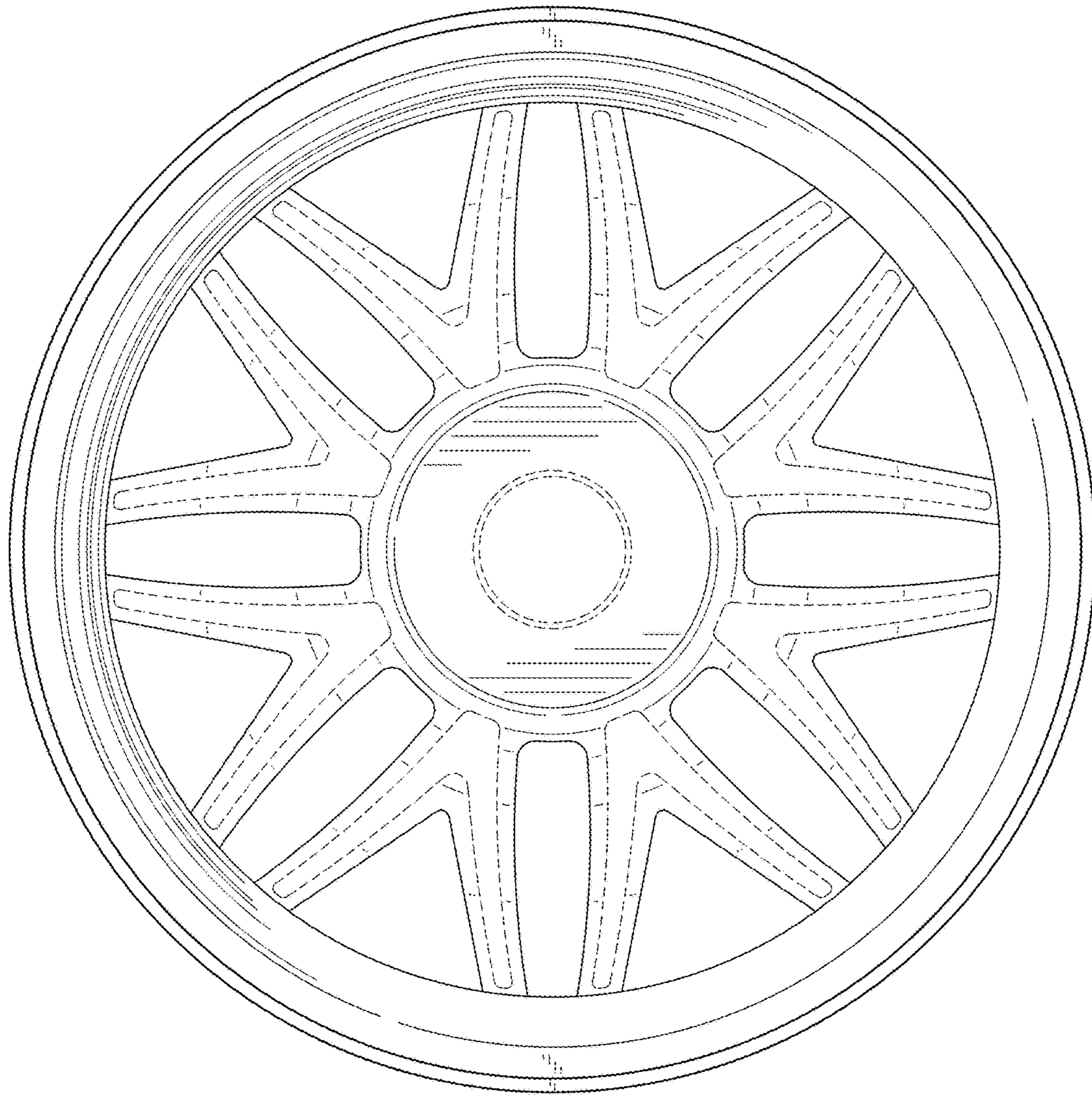

FIG. 3

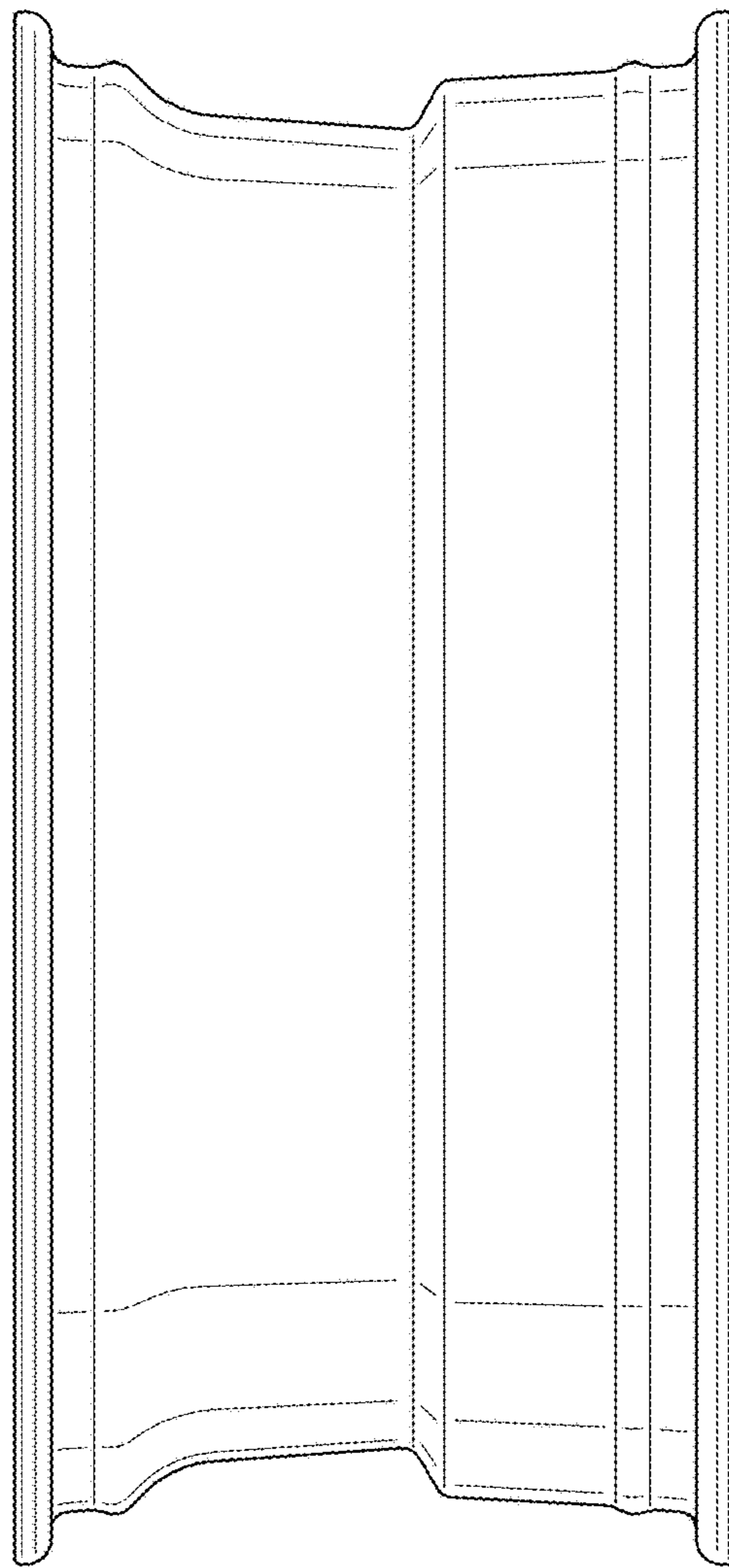

FIG. 4

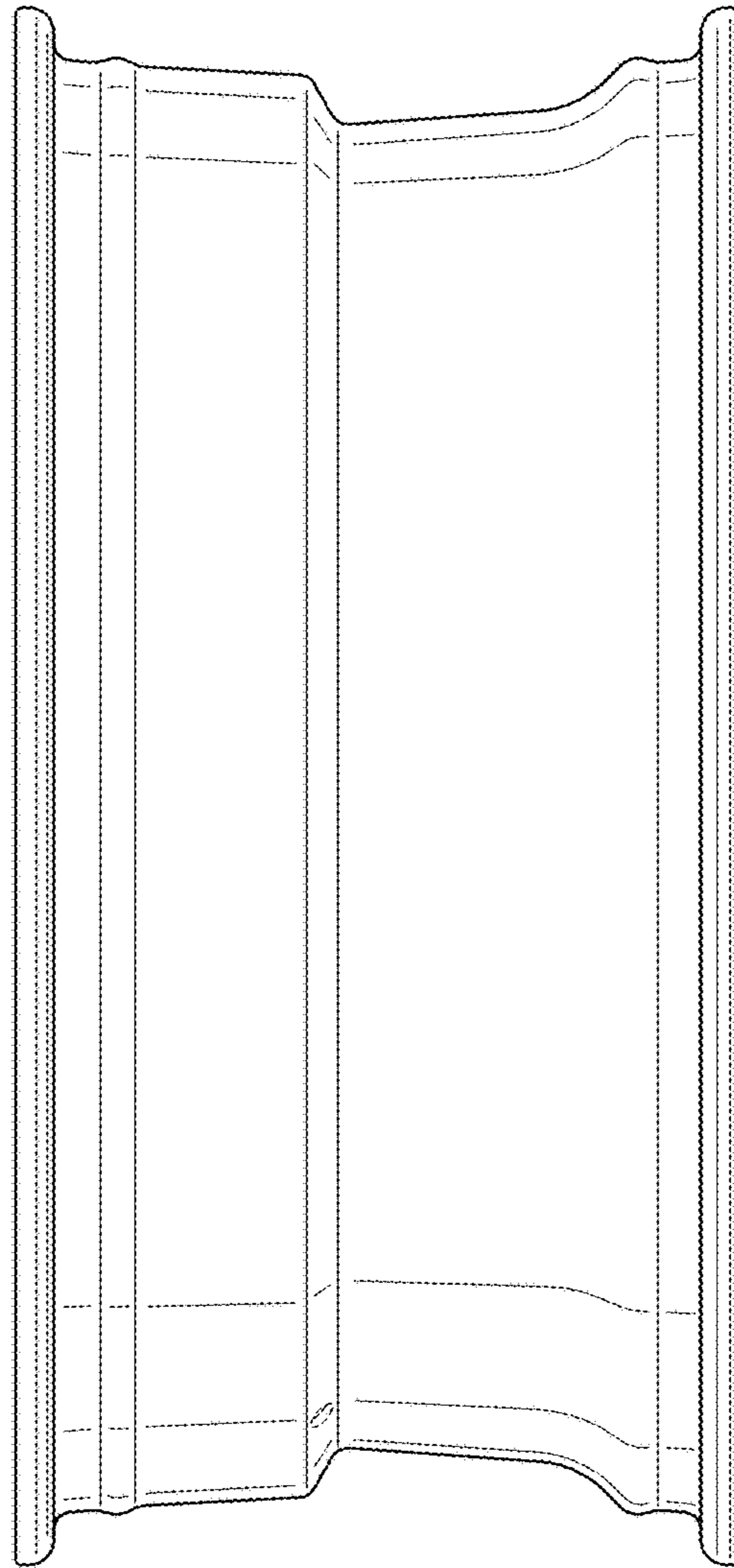

FIG. 5

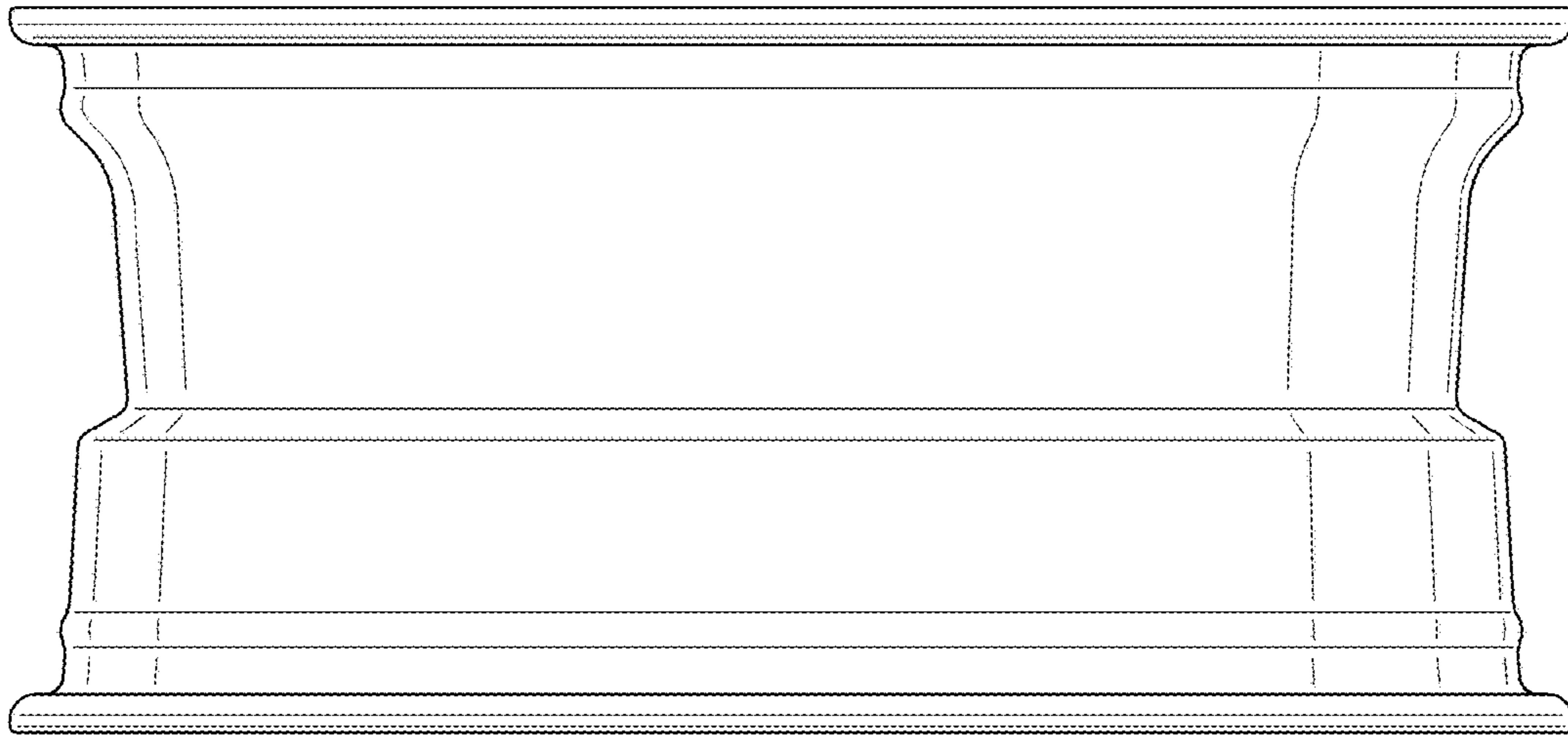

FIG. 6

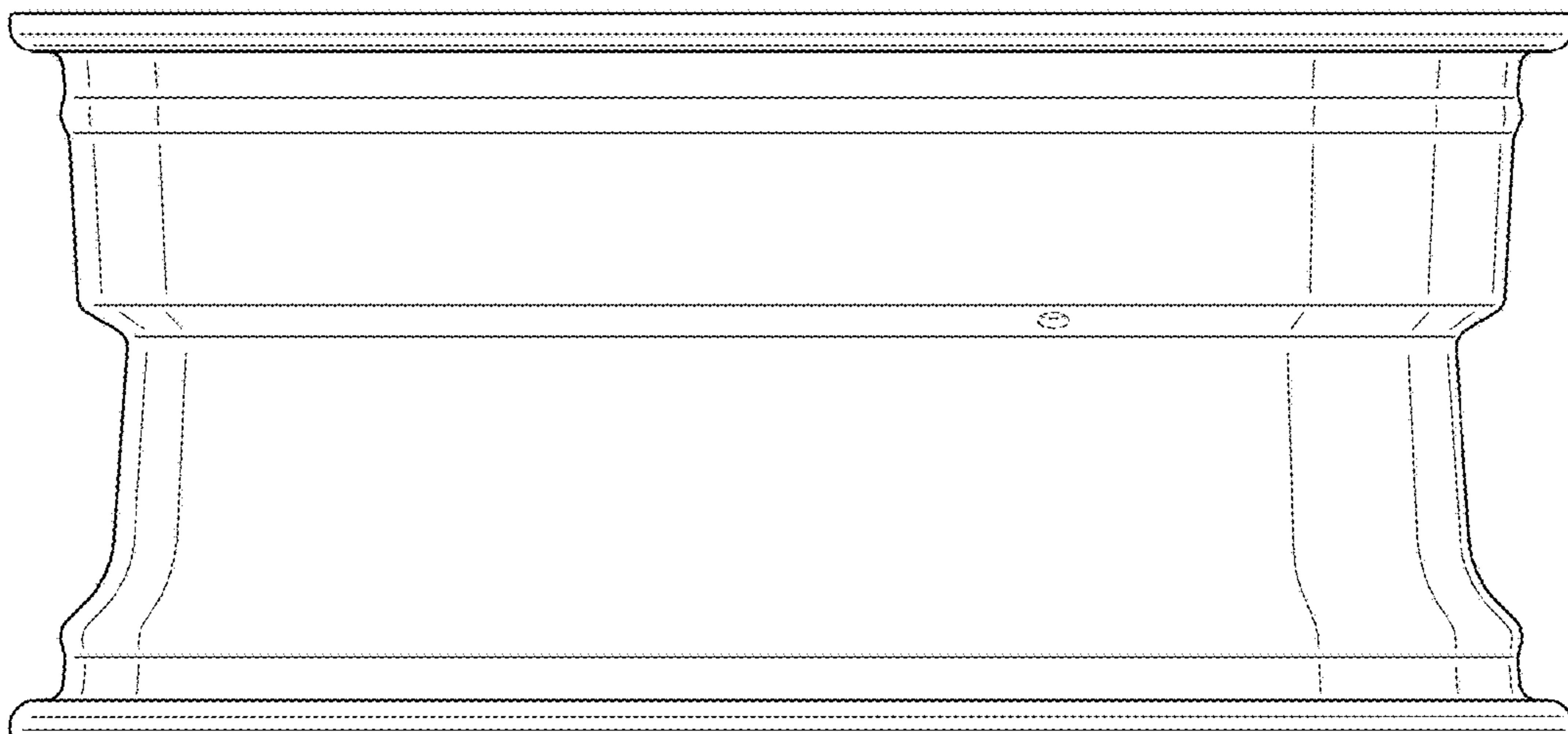

FIG. 7

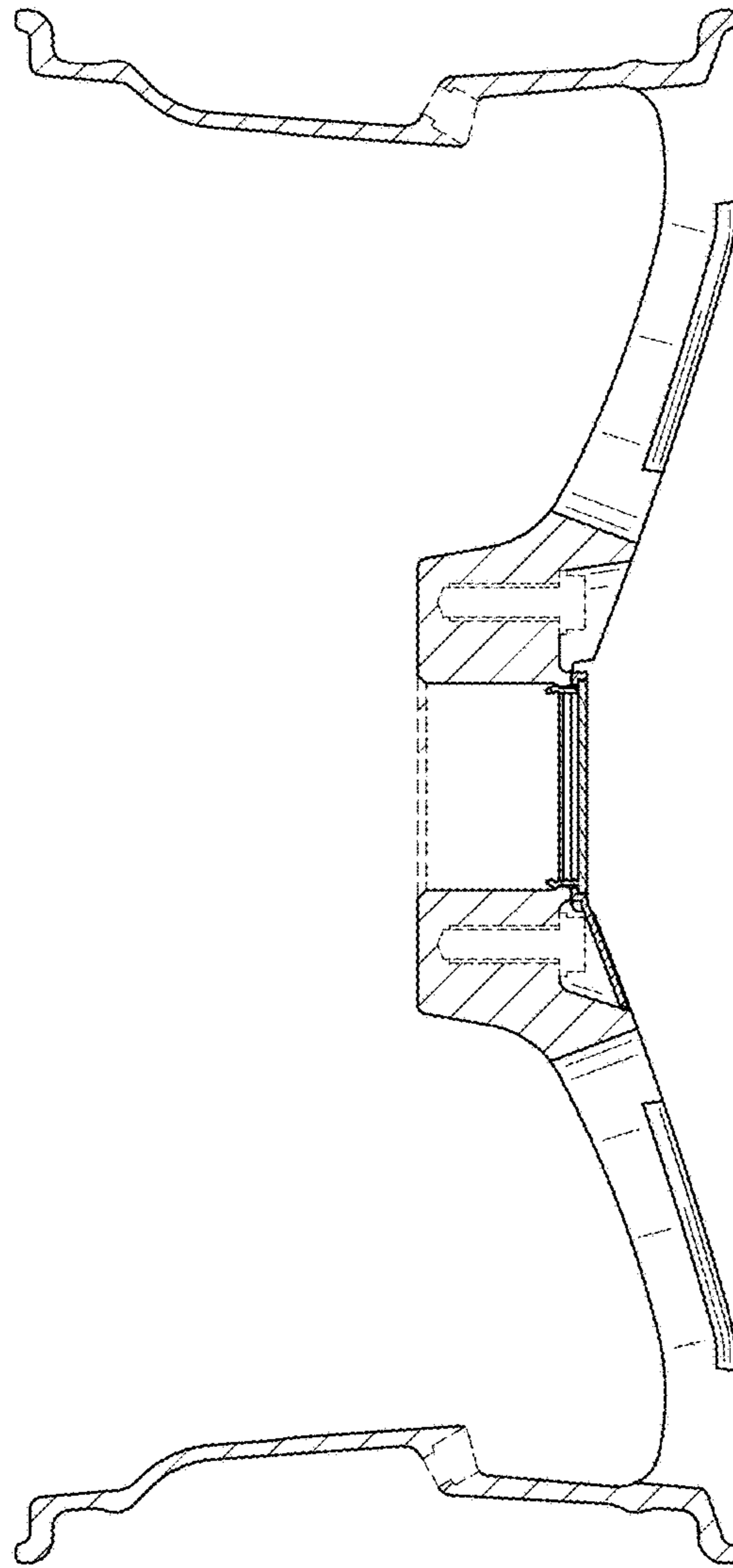

FIG. 8

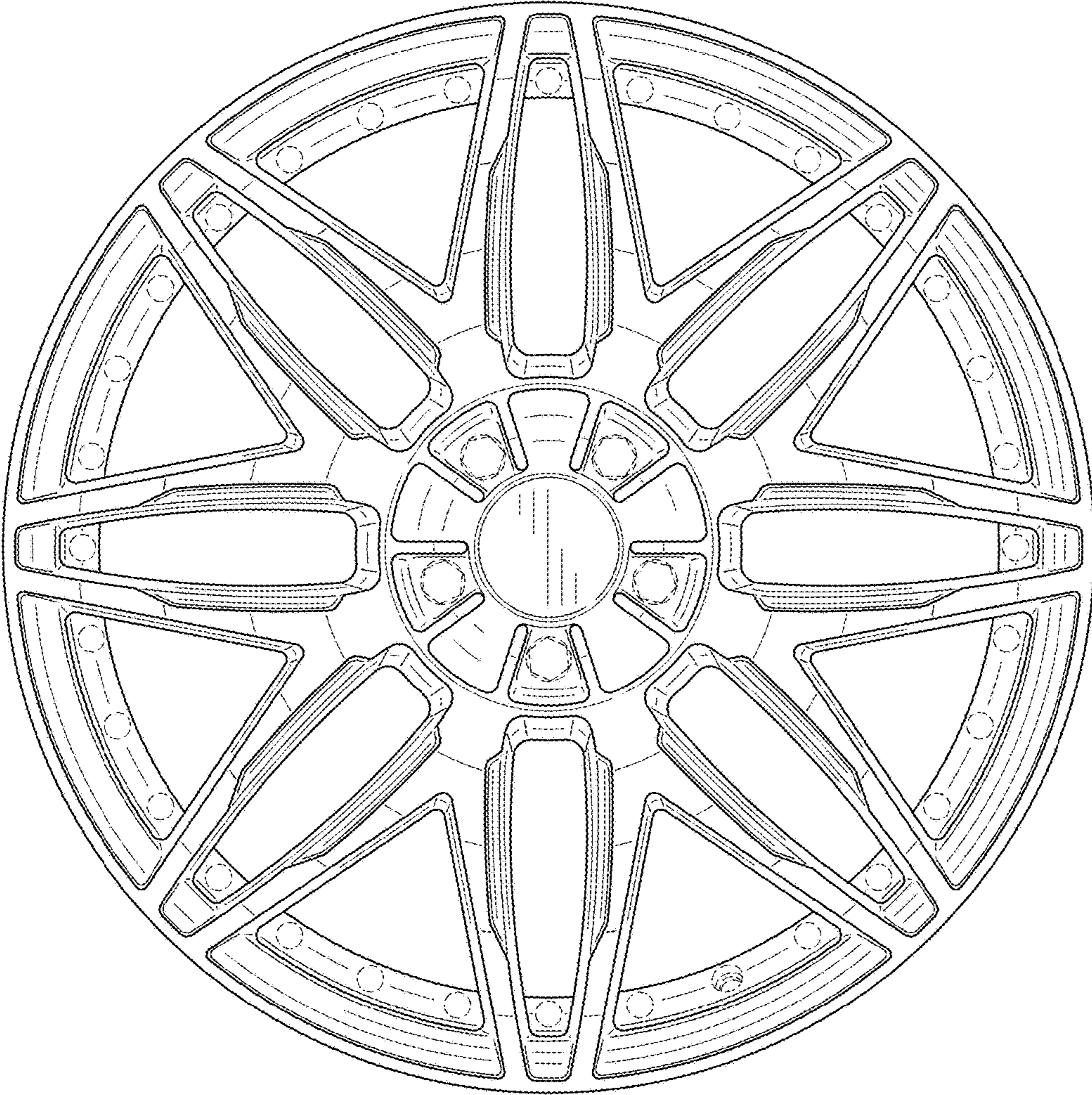

FIG. 9