



US00D844488S

(12) **United States Design Patent** (10) **Patent No.:** **US D844,488 S**
Melville et al. (45) **Date of Patent:** **** Apr. 2, 2019**

(54) **CAR**
(71) Applicant: **McLaren Automotive Limited**,
Woking, Surrey (GB)
(72) Inventors: **Robert Melville**, Ottershaw (GB);
Esteban Palazzo, Woking (GB)
(73) Assignee: **McLaren Automotive Limited**,
Woking, Surrey (GB)

D772,106 S * 11/2016 Hitzinger D12/88
D774,947 S * 12/2016 Anscheidt D12/88
D780,063 S 2/2017 Stephenson
D781,747 S 3/2017 Stephenson
D790,398 S * 6/2017 Perini D12/88
D790,402 S * 6/2017 Perini D12/88
D801,227 S 10/2017 Stephenson
D804,355 S 12/2017 Stephenson
D823,724 S 7/2018 Melville et al.

(**) Term: **15 Years**
(21) Appl. No.: **29/634,771**

FOREIGN PATENT DOCUMENTS
EM 002105403-0001 9/2012
EM 002105403-0002 9/2012

(22) Filed: **Jan. 24, 2018**
(30) **Foreign Application Priority Data**

* cited by examiner
Primary Examiner — Melody N Brown
(74) *Attorney, Agent, or Firm* — Wolf, Greenfield & Sacks, P.C.

Jul. 25, 2017 (GB) 6015953
(51) **LOC (11) Cl.** **12-08**
(52) **U.S. Cl.**
USPC **D12/88**
(58) **Field of Classification Search**
USPC D12/86, 90-92, 88; D21/424, 433, 434;
296/181.1-181.5, 183.1
CPC B62D 25/00; B62D 25/06; B62D 33/00;
B62D 35/00
See application file for complete search history.

(56) **References Cited**
U.S. PATENT DOCUMENTS

(57) **CLAIM**
The ornamental design for a car, as shown and described.

D628,124 S 11/2010 Stephenson
D715,690 S * 10/2014 Perini D12/88
D717,211 S 11/2014 Stephenson
D734,212 S 7/2015 Stephenson
D734,213 S 7/2015 Stephenson
D767,446 S 9/2016 Stephenson

DESCRIPTION
FIG. 1 is a top, front, right side perspective view of a car showing our new design;
FIG. 2 is a top, rear, left side perspective view thereof;
FIG. 3 is a right side elevation view thereof;
FIG. 4 is a left side elevation view thereof;
FIG. 5 is a front elevation view thereof;
FIG. 6 is a rear elevation view thereof; and,
FIG. 7 is a top plan view thereof.
The dot-dash broken lines in the figures illustrate boundaries of the claimed design and form no part thereof. The dash-dash broken lines illustrate portions of the car that form no part of the claimed design.

1 Claim, 6 Drawing Sheets

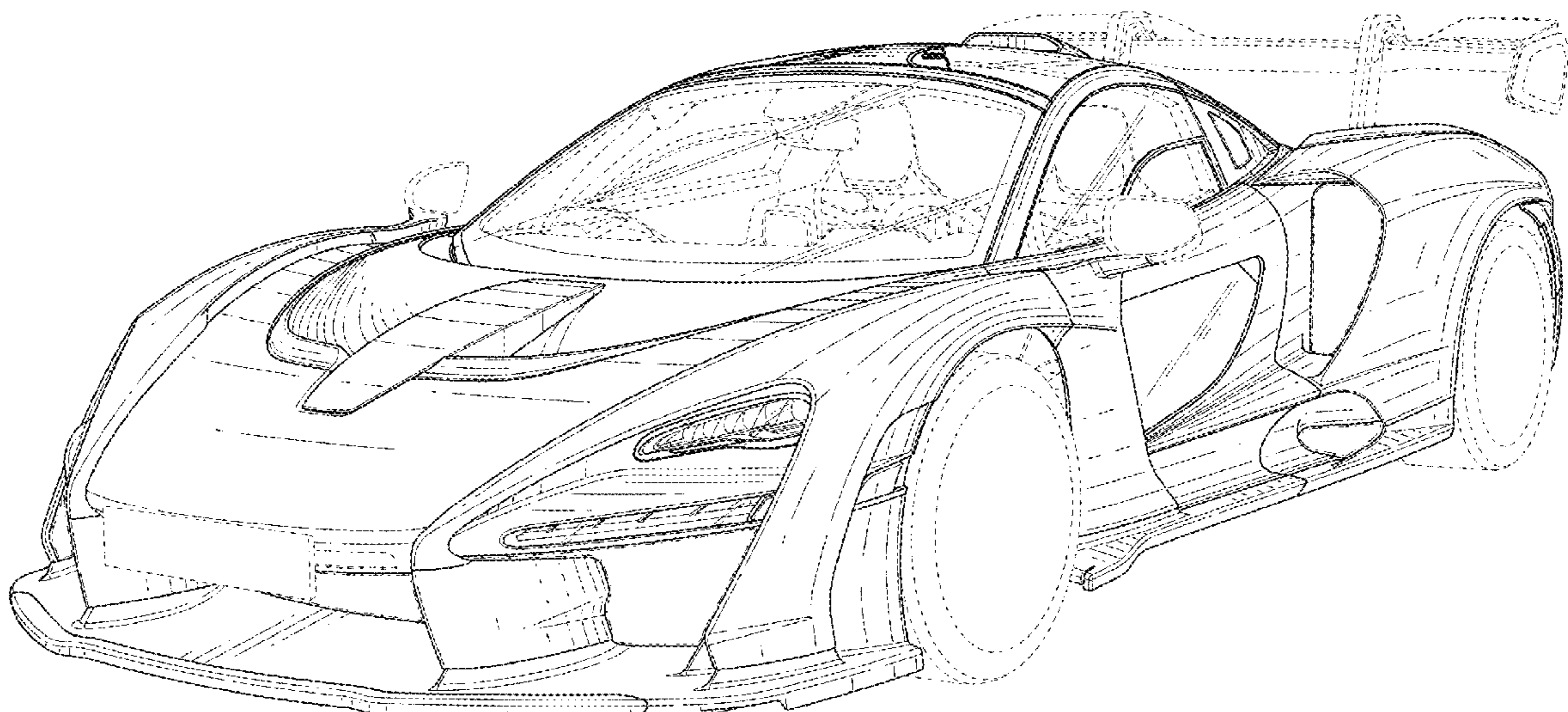

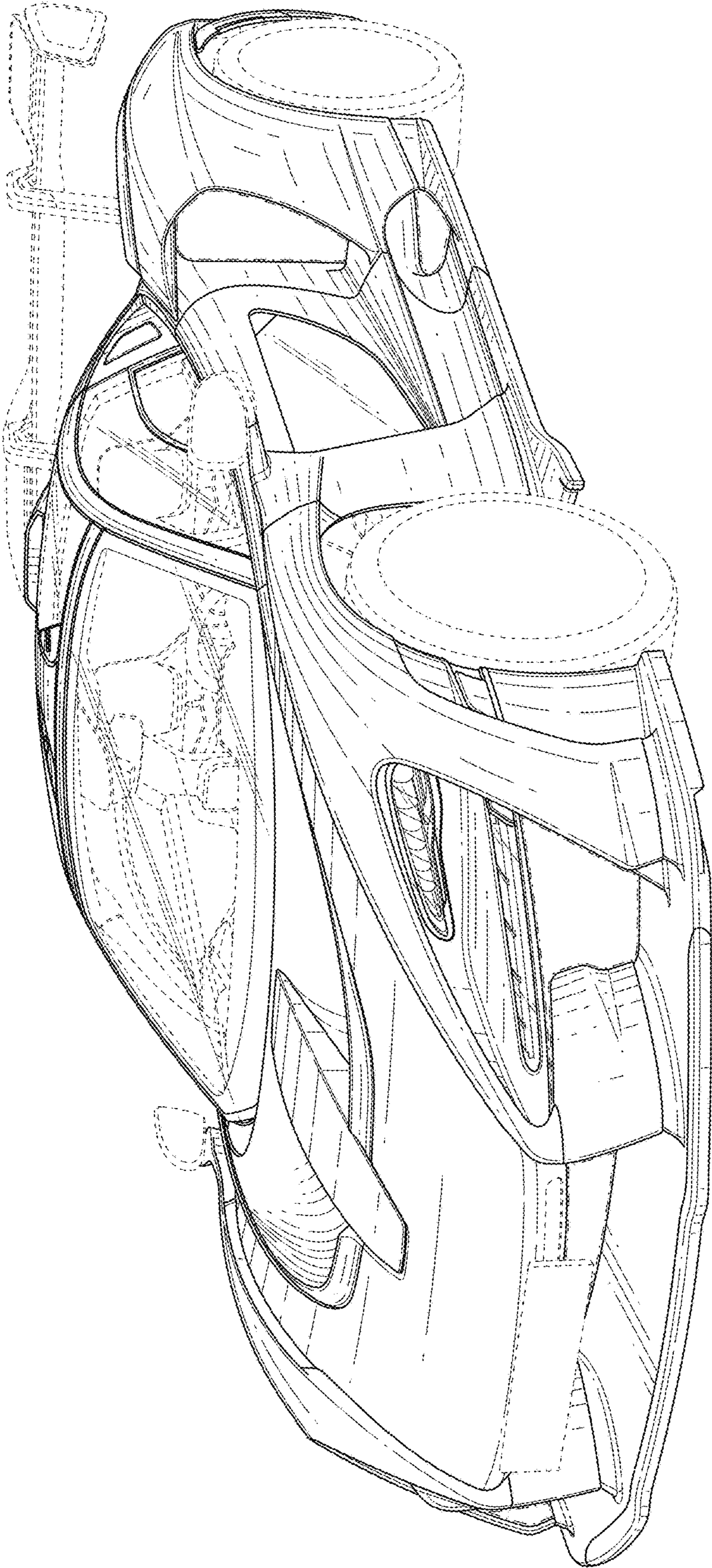

FIG. 1

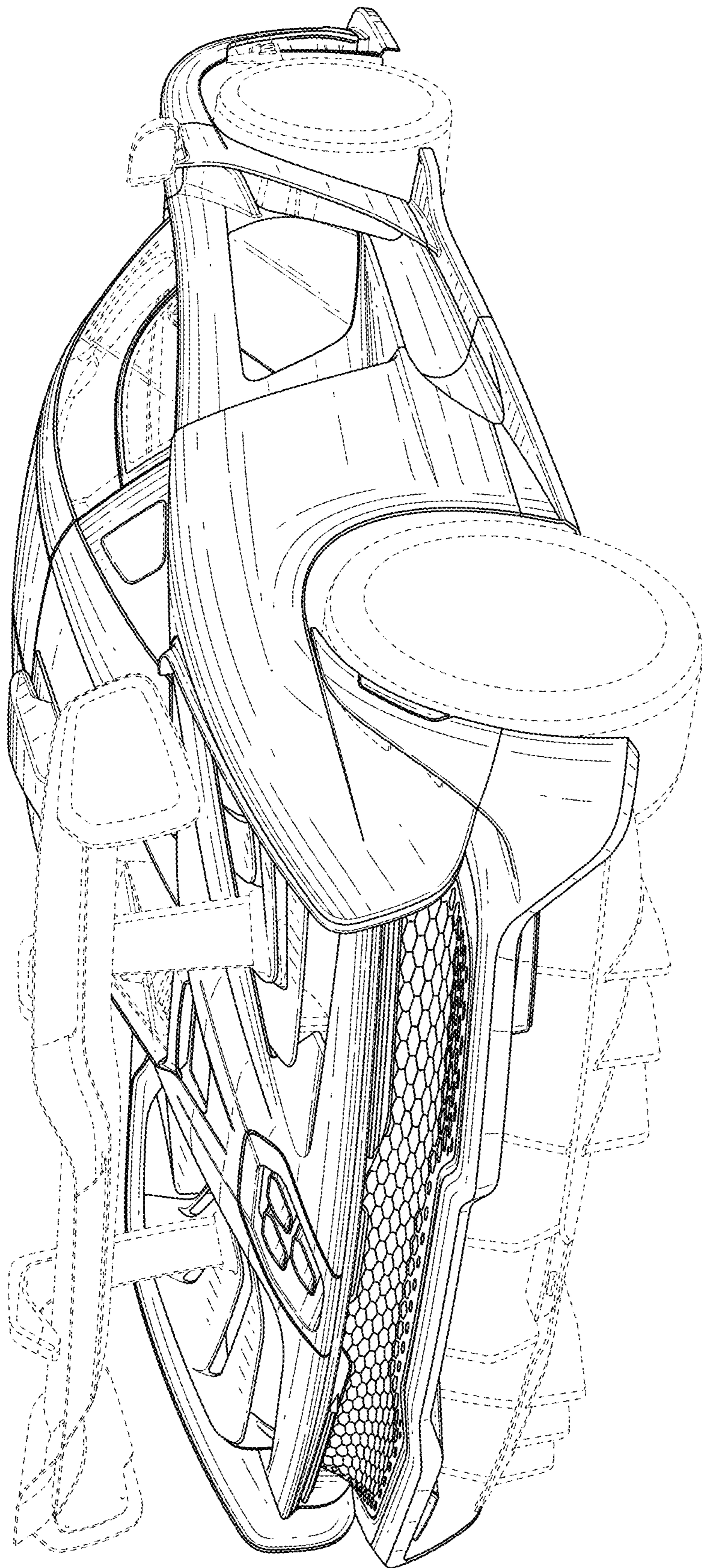

FIG. 2

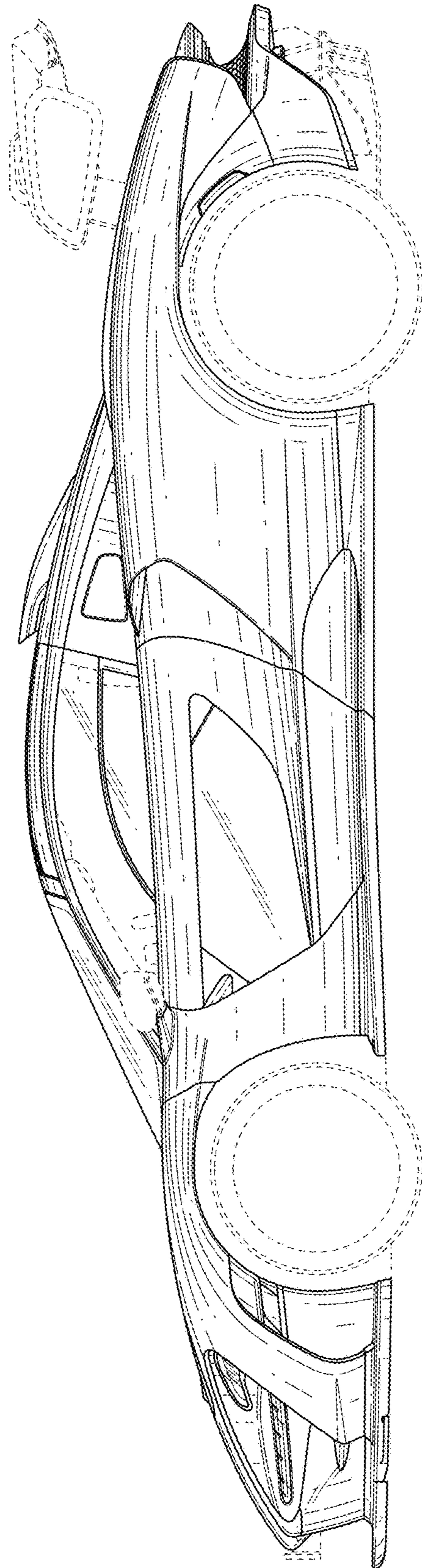

FIG. 3

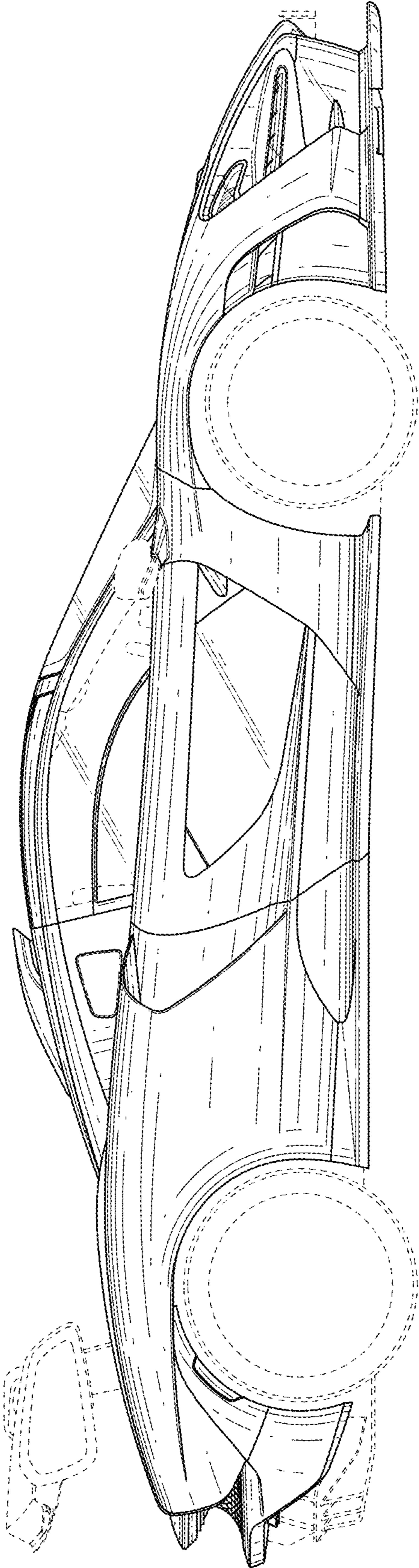

FIG. 4

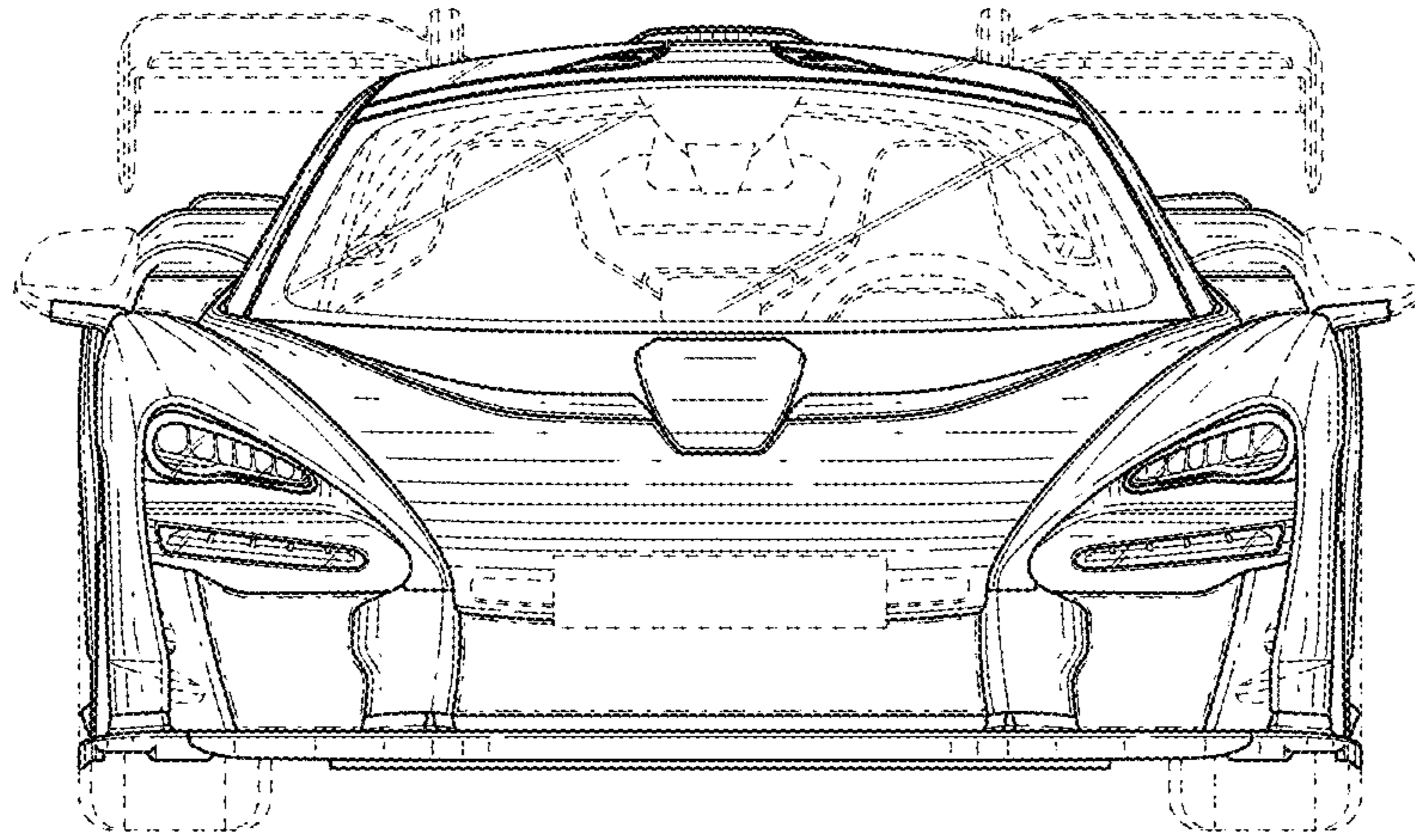

FIG. 5

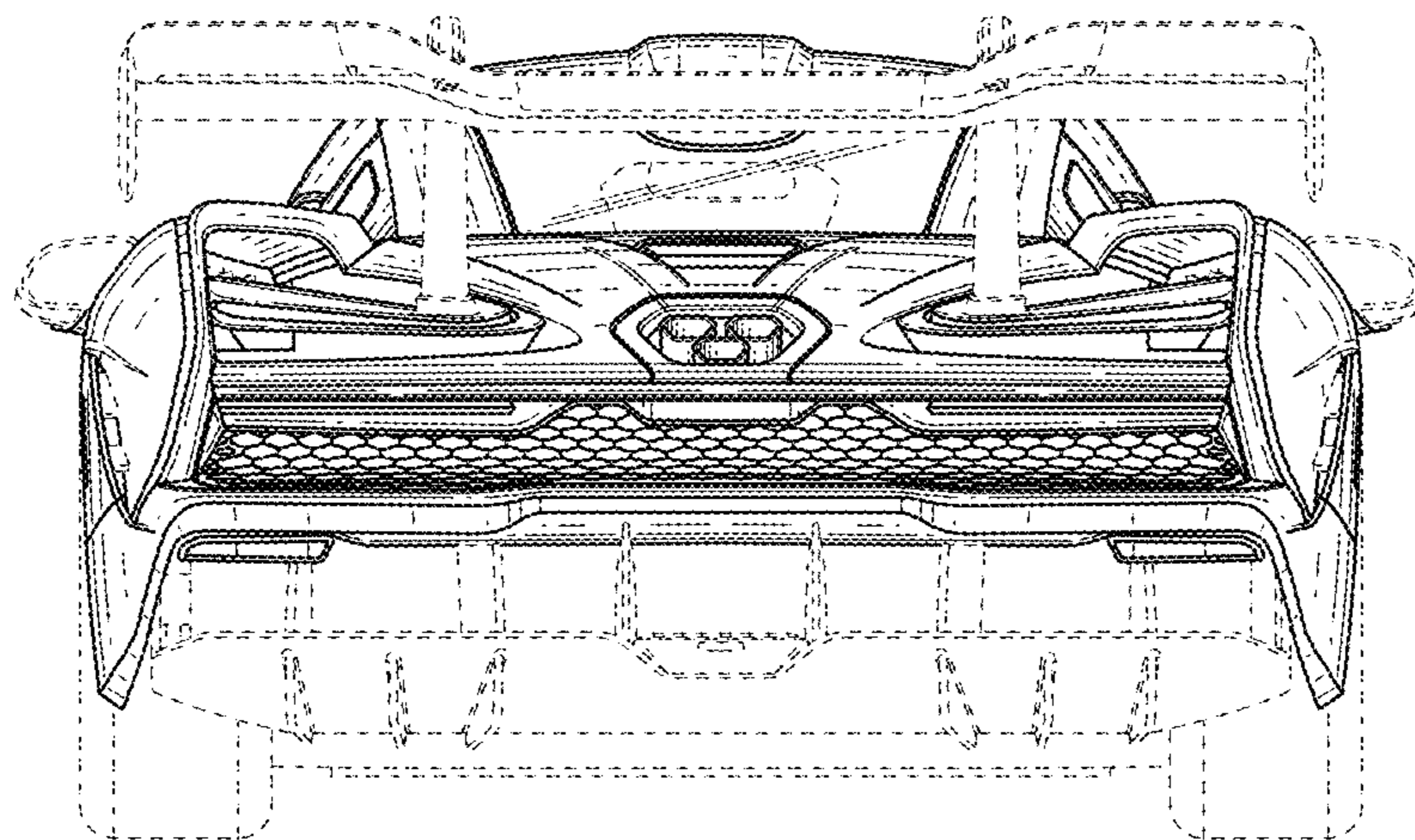

FIG. 6

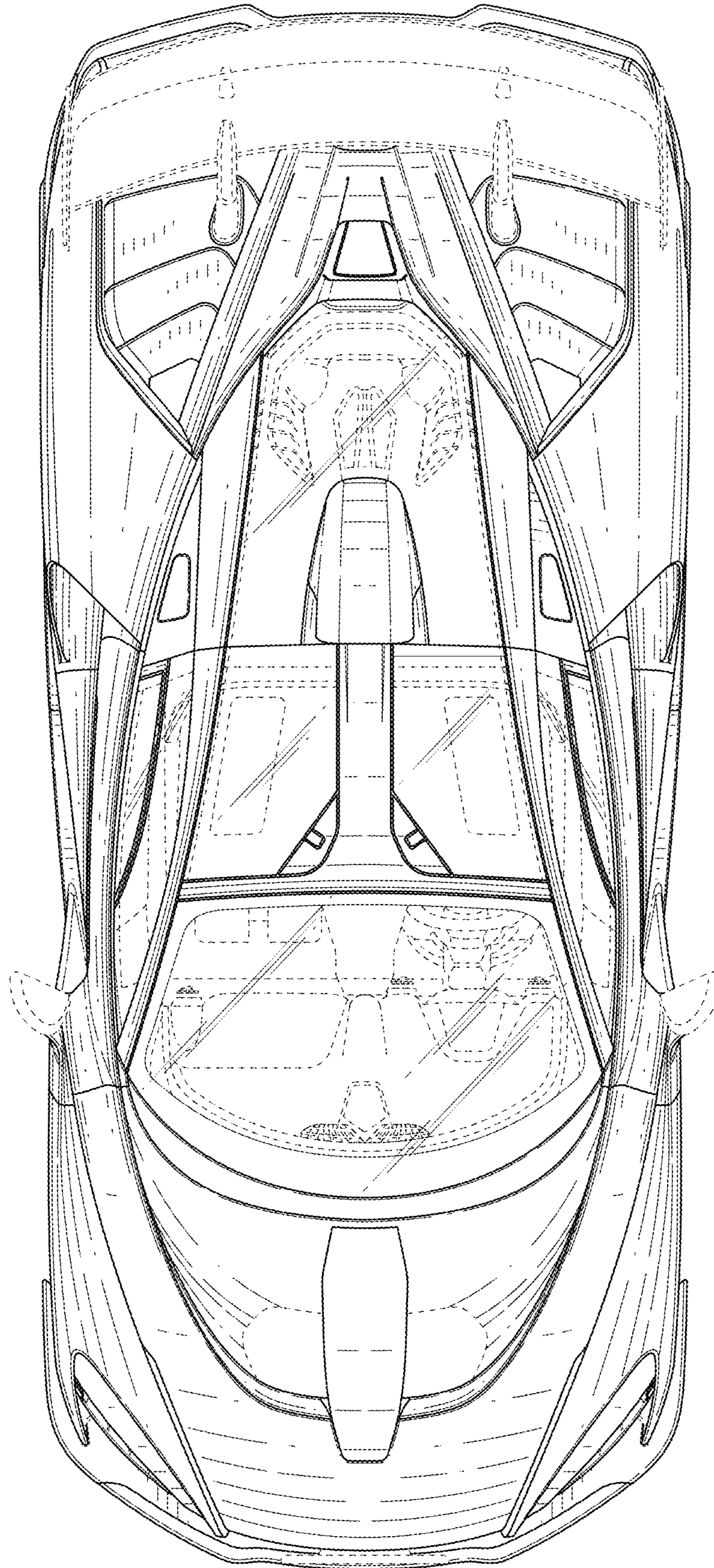

FIG. 7