



US00D844192S

(12) **United States Design Patent** (10) **Patent No.:** **US D844,192 S**
Nordmann (45) **Date of Patent:** **** Mar. 26, 2019**

(54) **TAILLIGHT FOR A VEHICLE**
(71) Applicant: **Bayerische Motoren Werke Aktiengesellschaft, Munich (DE)**
(72) Inventor: **Christoph Nordmann, Munich (DE)**
(73) Assignee: **Bayerische Motoren Werke Aktiengesellschaft, Munich (DE)**

D739,583 S * 9/2015 Forsgren D26/28
D743,063 S * 11/2015 Park D26/28
D760,410 S * 6/2016 Arroba D26/28
D764,691 S * 8/2016 Luk D26/28
D767,178 S * 9/2016 Liu D26/28
D768,894 S * 10/2016 Faghihzadeh D26/28
D769,485 S * 10/2016 Morikawa D26/28
D792,621 S * 7/2017 Komuro D26/28

(Continued)

(**) Term: **15 Years**
(21) Appl. No.: **29/605,306**
(22) Filed: **May 25, 2017**

FOREIGN PATENT DOCUMENTS

WO WO DM/080343 8/2013
WO WO DM/080366 9/2013
WO WO DM/094975 2/2017

(30) **Foreign Application Priority Data**
Nov. 30, 2016 (DE) 40 2016 101 441
(51) **LOC (11) Cl.** **26-06**
(52) **U.S. Cl.**
USPC **D26/28**
(58) **Field of Classification Search**
USPC D12/86, 90-92, 114, 163, 169, 171-173,
D12/181, 190, 196, 197, 199, 400;
D26/28-36
CPC ... B62J 6/02; B62J 6/00; B60Q 3/0279; F21S
48/00; F21S 48/10; F21S 48/115; F21S
48/225; F21S 48/1233; F21S 48/1266;
F21S 48/1388; F21S 48/2268; F21V
21/04
See application file for complete search history.

Primary Examiner — Philip S Hyder
Assistant Examiner — Cary M Robinson
(74) *Attorney, Agent, or Firm* — Crowell & Moring LLP

(57) **CLAIM**

The ornamental design for a taillight for a vehicle, as shown and described.

DESCRIPTION

This application contains subject matter related to the following co-pending U.S. design patent applications: Application Ser. No. 29/594,700, filed Feb. 22, 2017 and entitled "Taillight for a Vehicle"; Application Ser. No. 29/605,288, filed herewith and entitled "Vehicle, Toy, and/or Replicas Thereof"; and Application Ser. No. 29/605,303, filed herewith and entitled "Taillight for a Vehicle".
FIG. 1 is a front view of a taillight for a vehicle according to the design;
FIG. 2 is a left perspective view thereof;
FIG. 3 is a right perspective view thereof;
FIG. 4 is a left side view thereof;
FIG. 5 is a right side view thereof;
FIG. 6 is a top view thereof;
FIG. 7 is a bottom view thereof; and,
FIG. 8 is a rear view thereof.

(56) **References Cited**

U.S. PATENT DOCUMENTS

D646,815 S * 10/2011 Goplen D26/28
D686,358 S * 7/2013 Morgenstern D26/28
D694,440 S 11/2013 Johnson
D714,984 S * 10/2014 Lai D26/28
D716,478 S * 10/2014 Loeb D26/28
D719,691 S 12/2014 Nordmann
D737,480 S * 8/2015 Park D26/28

1 Claim, 8 Drawing Sheets

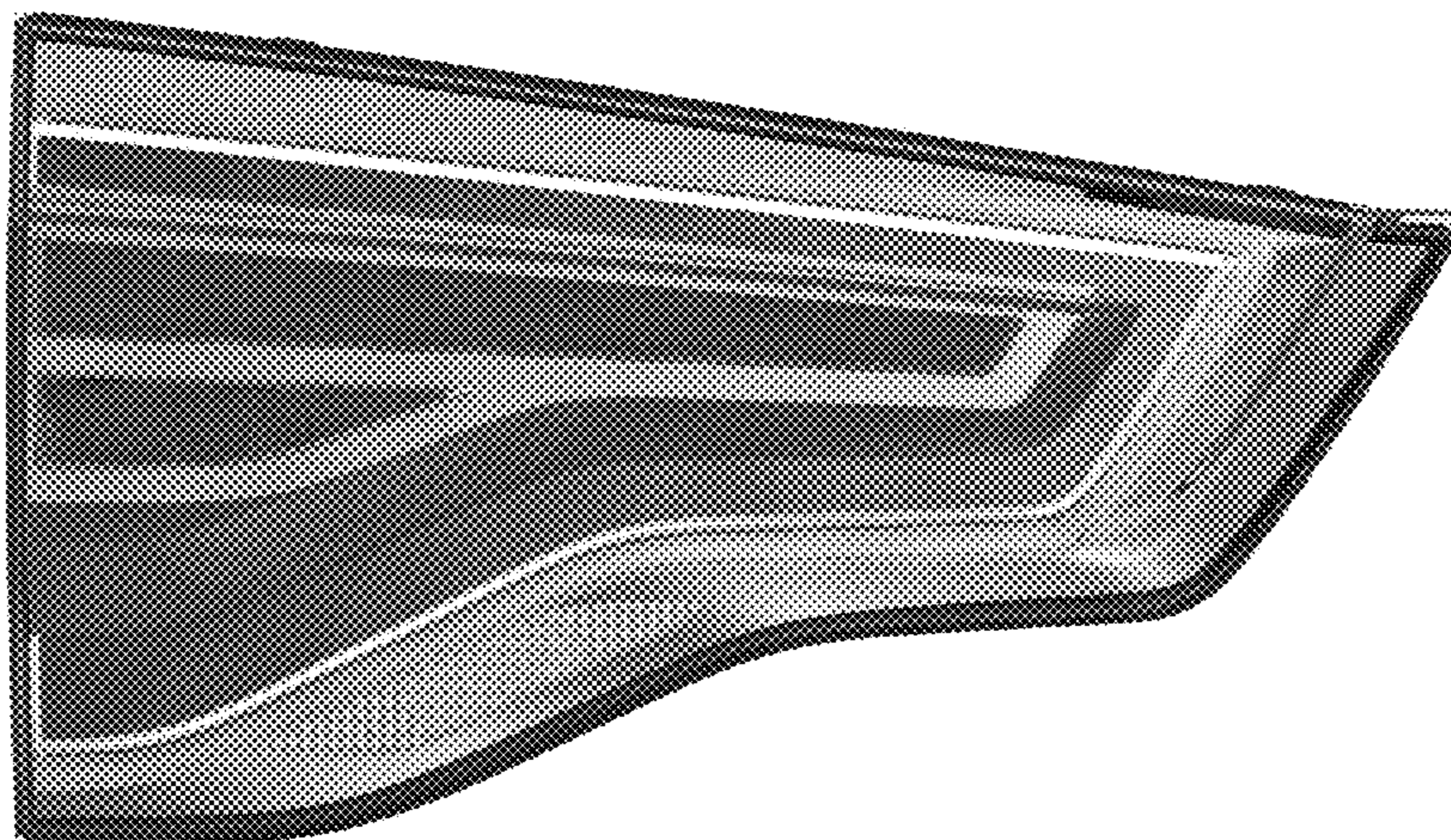

(56)

References Cited

U.S. PATENT DOCUMENTS

D792,989	S	*	7/2017	Han	D26/28
D803,438	S	*	11/2017	Badstuebner	D26/28
D803,439	S	*	11/2017	Oh	D26/28
D806,921	S	*	1/2018	Ryu	D26/28
D810,974	S	*	2/2018	Sato	D26/28
D811,633	S	*	2/2018	Gould	D26/28
D812,263	S	*	3/2018	Minamiyama	D26/28
D812,264	S	*	3/2018	Minamiyama	D26/28
D812,789	S	*	3/2018	Dos Santos	D26/28
D822,244	S	*	7/2018	Lee	D26/28
D822,862	S	*	7/2018	Hannemann	D26/28
D823,504	S	*	7/2018	Yoon	D26/28
D828,589	S	*	9/2018	Hannemann	D26/28
D828,590	S	*	9/2018	Hannemann	D26/28
D829,947	S	*	10/2018	Jung	D26/28
D829,948	S	*	10/2018	Jung	D26/28
D829,949	S	*	10/2018	Jung	D26/28

* cited by examiner

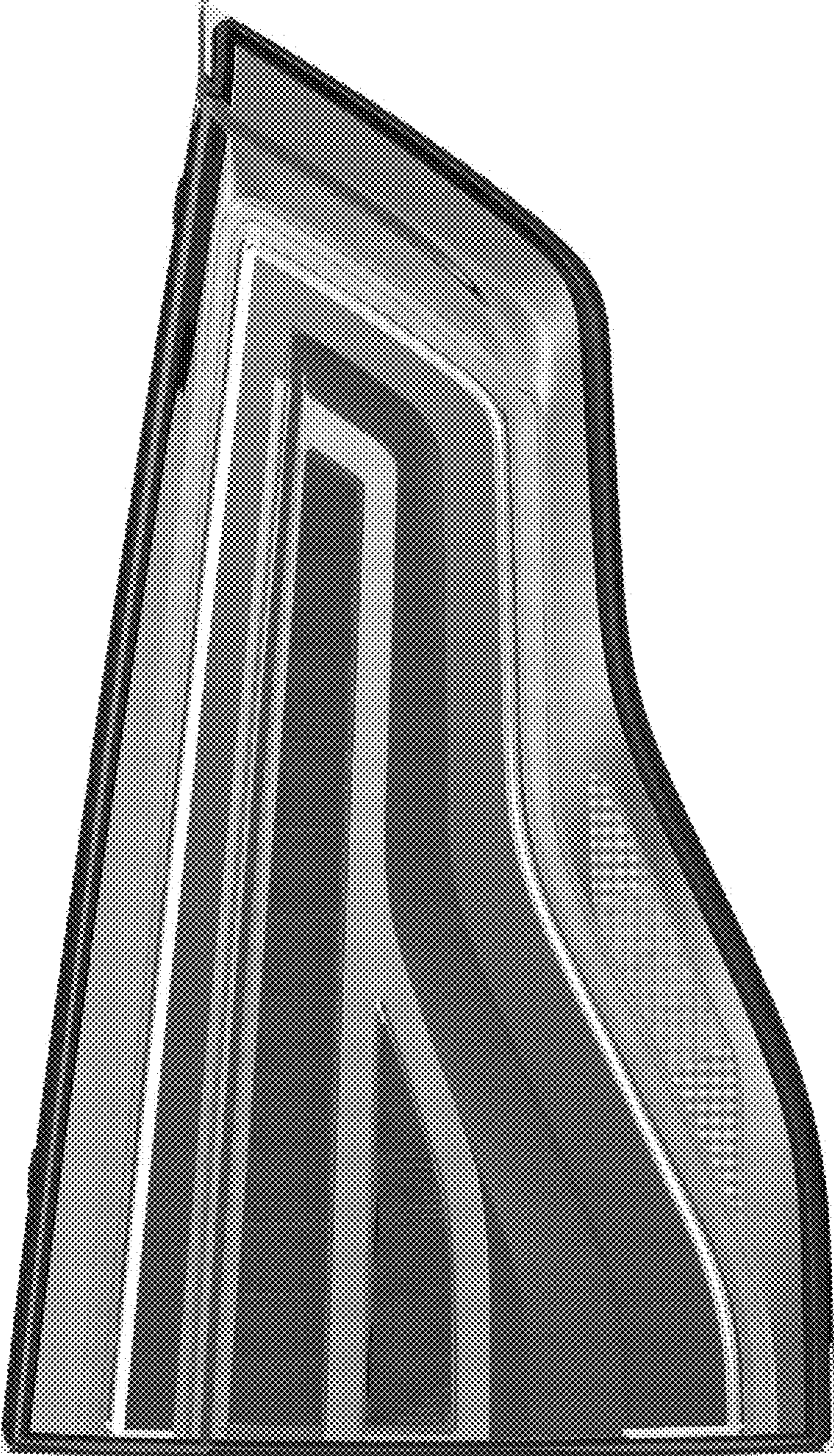

Fig. 1

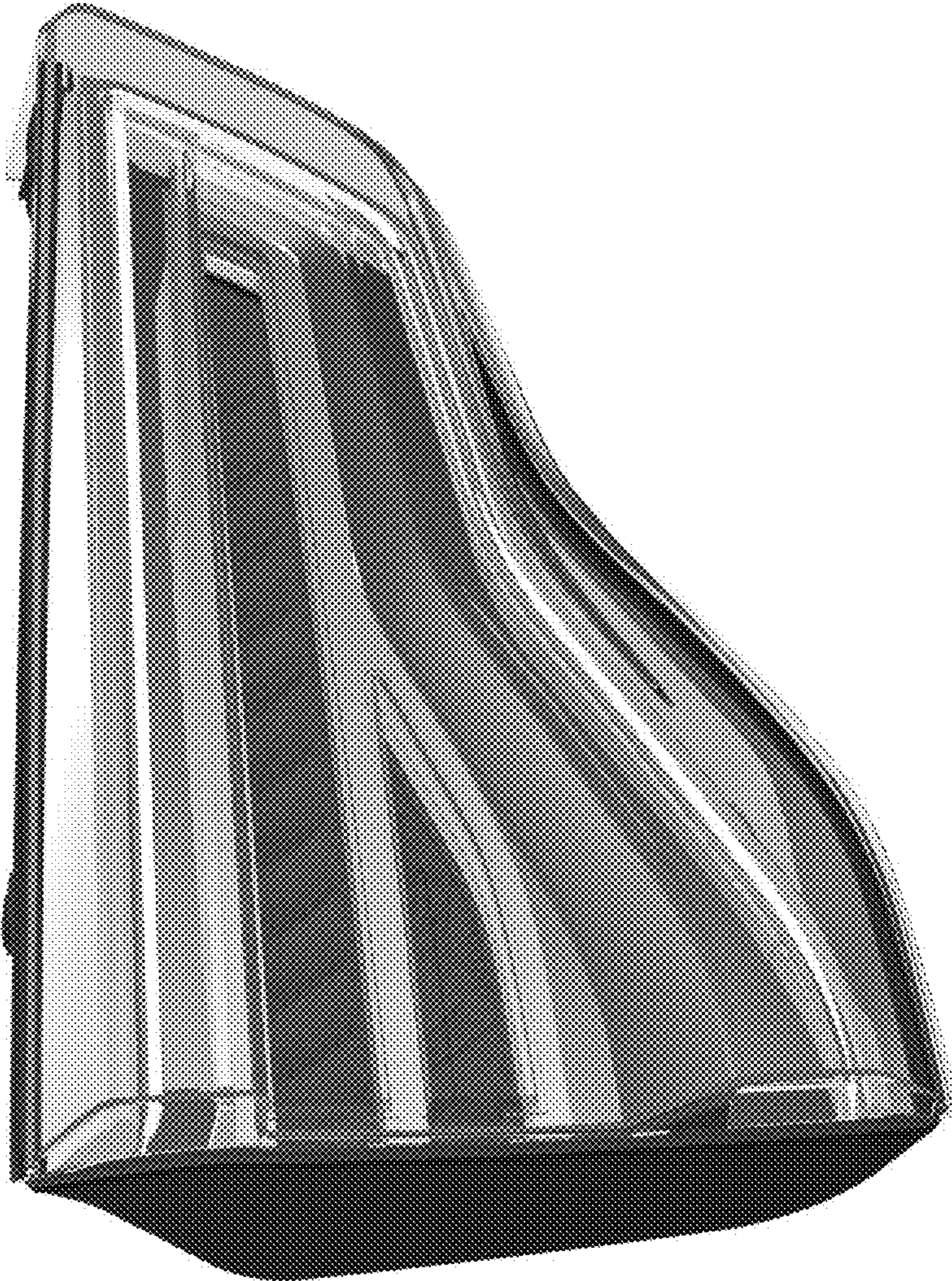

Fig. 2

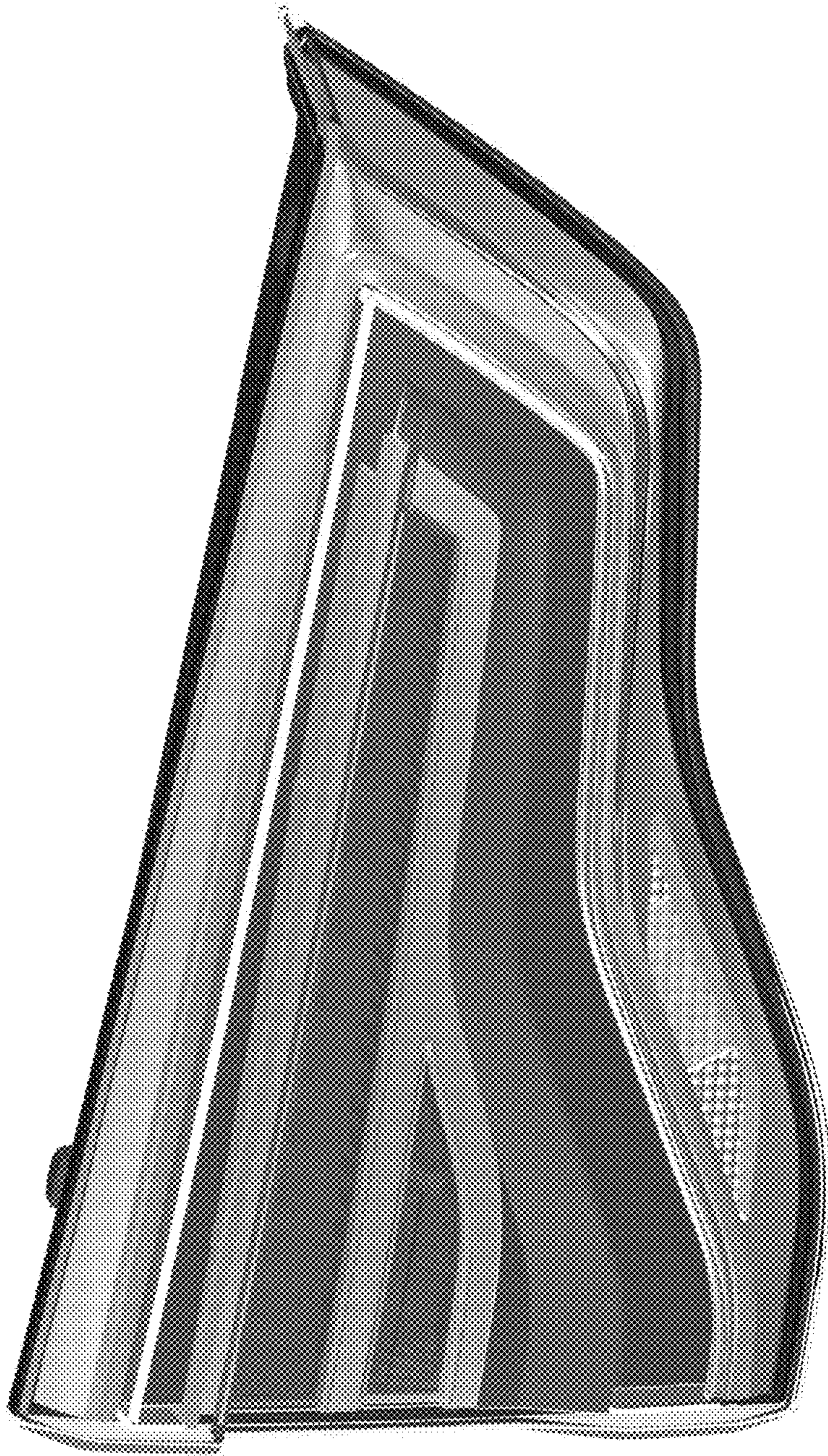

Fig. 3

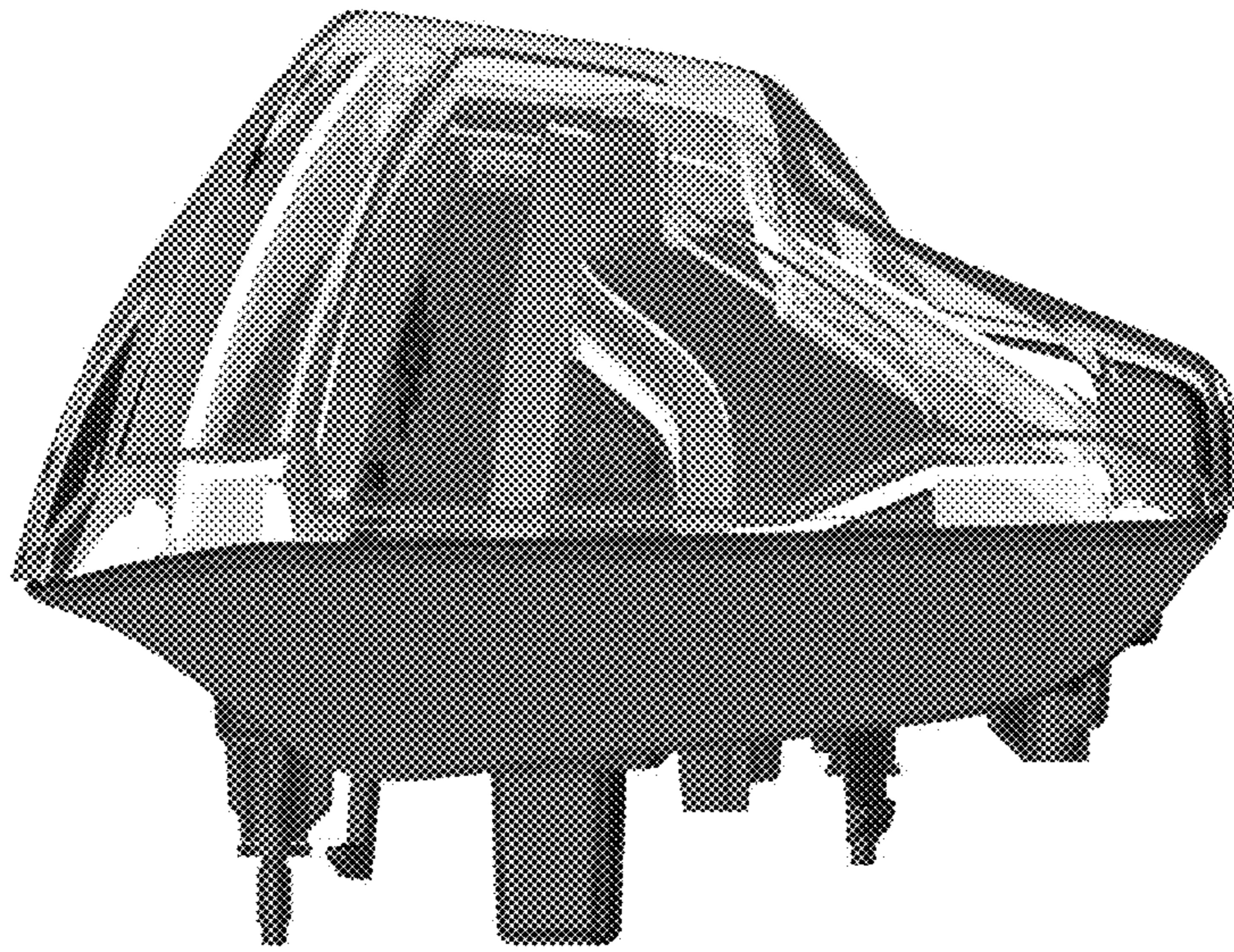

Fig. 4

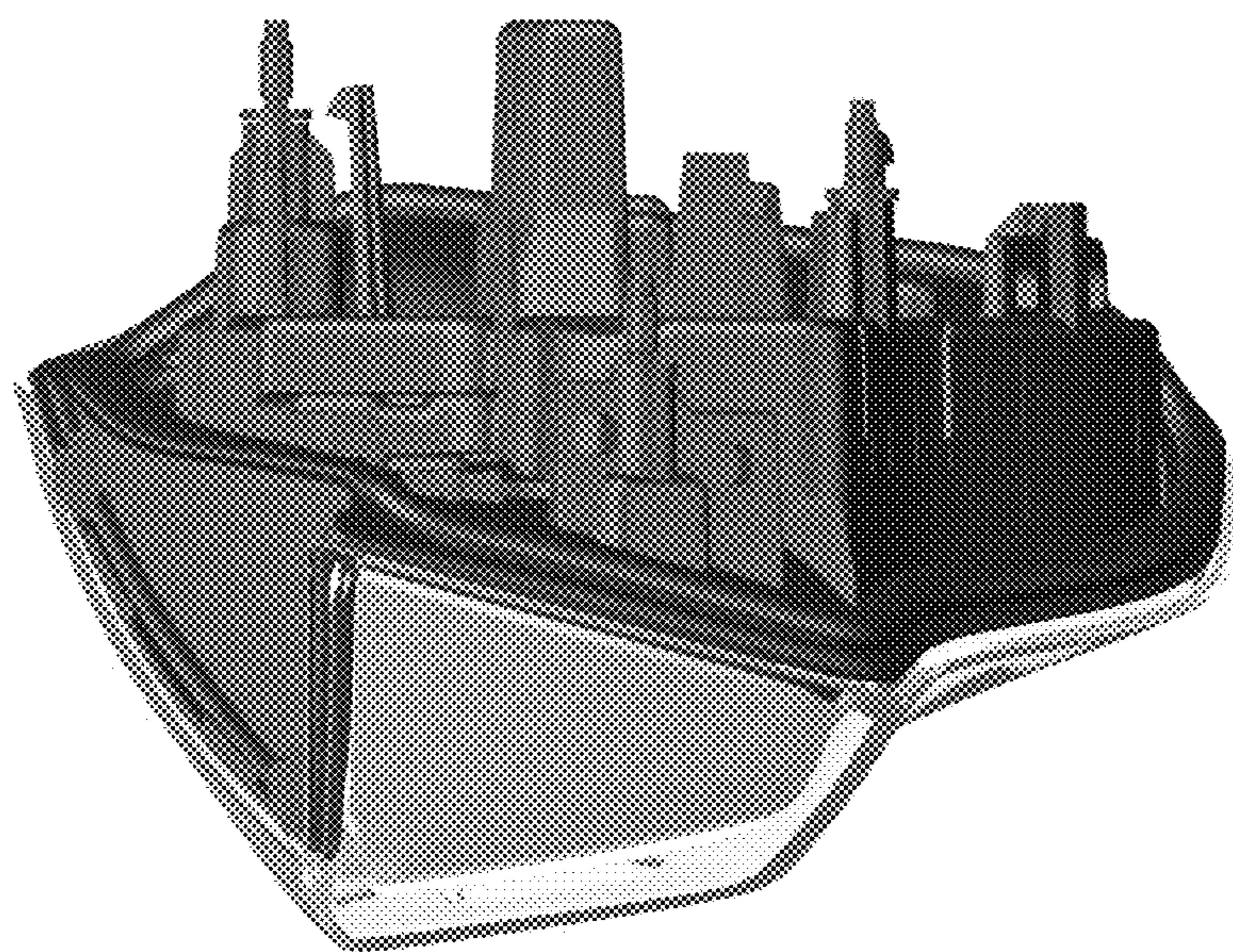

Fig. 5

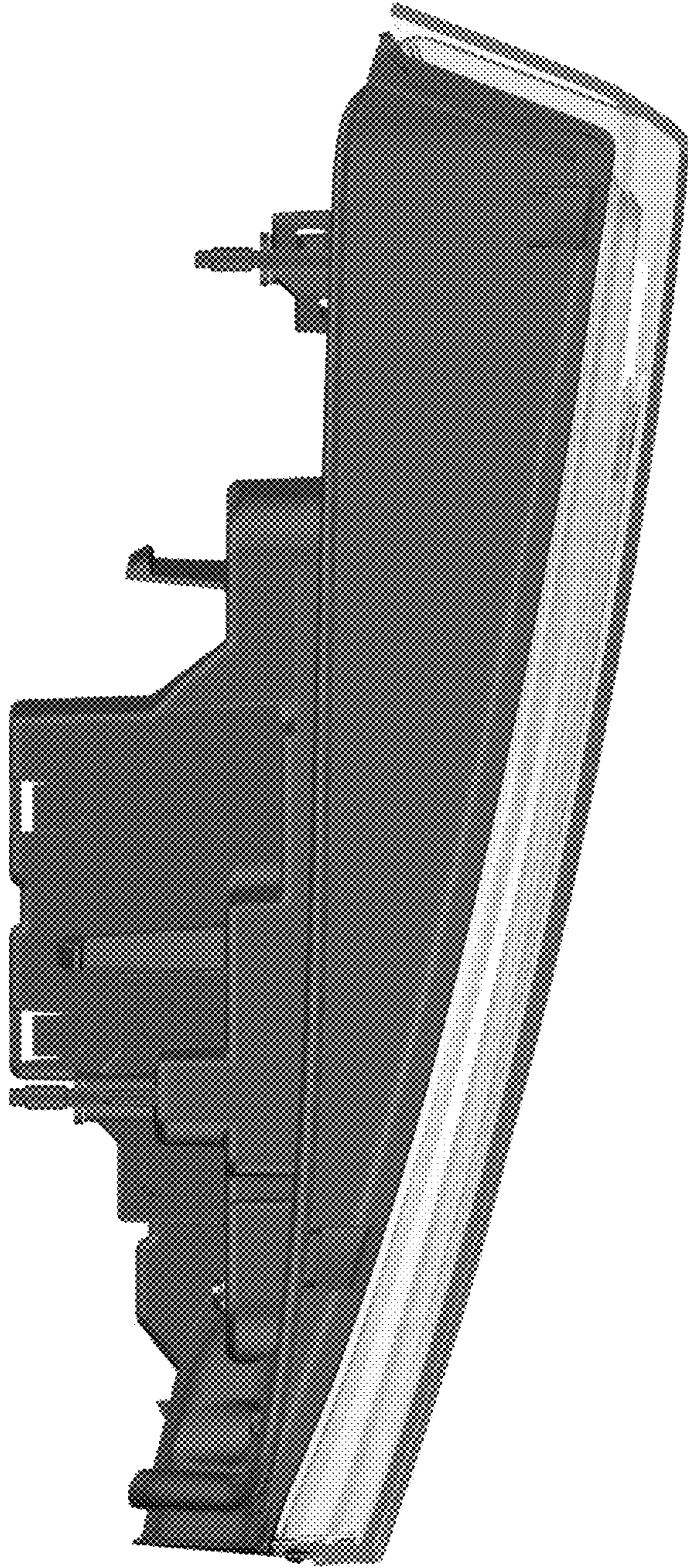

Fig. 6

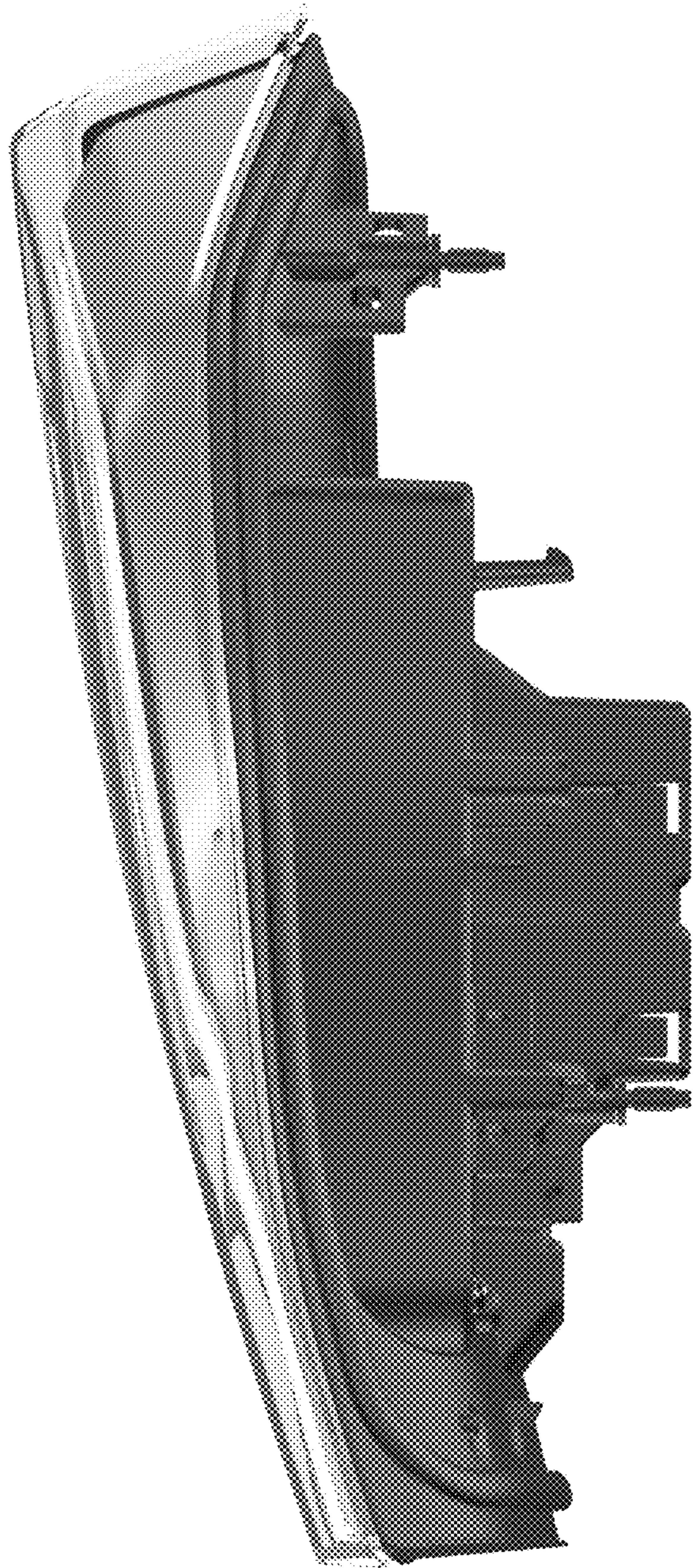

Fig. 7

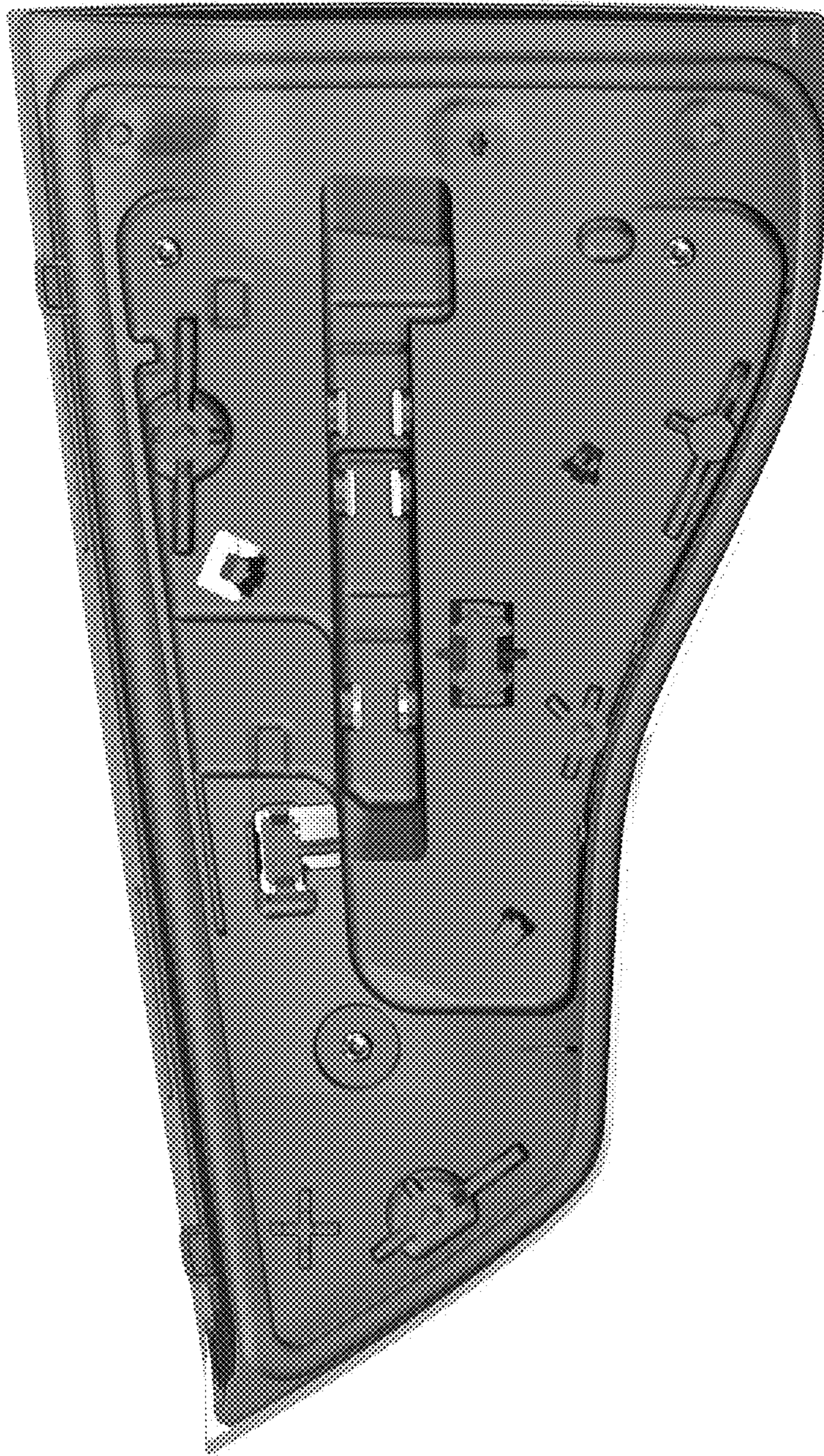

Fig. 8