



US00D844100S

(12) **United States Design Patent**
Parrott

(10) **Patent No.:** **US D844,100 S**
(45) **Date of Patent:** **** Mar. 26, 2019**

- (54) **FLAT-BOTTOM TRANSPORT NET**
- (71) Applicant: **Adam Parrott**, Monroe, TN (US)
- (72) Inventor: **Adam Parrott**, Monroe, TN (US)
- (**) Term: **15 Years**
- (21) Appl. No.: **29/658,015**
- (22) Filed: **Jul. 27, 2018**
- (51) **LOC (11) Cl.** **22-05**
- (52) **U.S. Cl.**
USPC **D22/135**
- (58) **Field of Classification Search**
USPC D22/135-136, 199; 43/4, 11, 54.1,
43/55-56; 114/343; 383/3, 117
CPC A01K 73/12; A01K 74/00; A01K 97/04;
A01K 97/05; A01K 97/20; B63B 59/02
See application file for complete search history.

- 6,883,265 B1 4/2005 Jenssen
- D518,551 S 4/2006 Moren
- D545,938 S 7/2007 Walters
- 7,918,049 B2 * 4/2011 Daley, III A01K 77/00
43/11
- 8,001,717 B1 8/2011 Bright, II
- 8,794,475 B1 8/2014 Daniels et al.
- D745,280 S 12/2015 Wang
- D754,280 S * 4/2016 Krieger D22/135
- D794,157 S 8/2017 Jones et al.
- 2008/0307693 A1 12/2008 Wessels

* cited by examiner

Primary Examiner — Catherine R Oliver-Garcia
(74) *Attorney, Agent, or Firm* — Ridgeline Venture Law;
Kevin Christopher

(57) **CLAIM**

The ornamental design for a flat bottom transport net, as shown and described.

DESCRIPTION

FIG. 1 is a perspective view of my new design for a flat-bottom transport net;
 FIG. 2 is a left side elevational view thereof;
 FIG. 3 is a right side elevational view thereof;
 FIG. 4 is a front elevational view thereof;
 FIG. 5 is a rear elevational view thereof;
 FIG. 6 is a top plan view thereof;
 FIG. 7 is a bottom plan view thereof; and,
 FIG. 8 is a left side view of the flat-bottom transport net attached to a sample kayak.
 The broken lines represent environmental structure and are for illustrative purposes only and form no part of the claimed design.

(56) **References Cited**

U.S. PATENT DOCUMENTS

- 2,169,941 A * 8/1939 Campbell A01K 97/05
43/55
- 3,919,803 A 11/1975 Manguso
- D254,503 S 3/1980 Belasquez
- D257,378 S 10/1980 Andrews
- D299,947 S 2/1989 Nelson et al.
- 4,890,413 A 1/1990 Nelson et al.
- D323,698 S 2/1992 Nelson et al.
- D336,508 S 6/1993 Mathews
- 5,299,530 A 4/1994 Mukadam et al.
- D367,102 S 2/1996 McLeaf
- 5,561,936 A 10/1996 Franke
- 5,732,645 A * 3/1998 Lemke B63B 59/02
114/343
- D485,329 S 1/2004 Haws

1 Claim, 8 Drawing Sheets

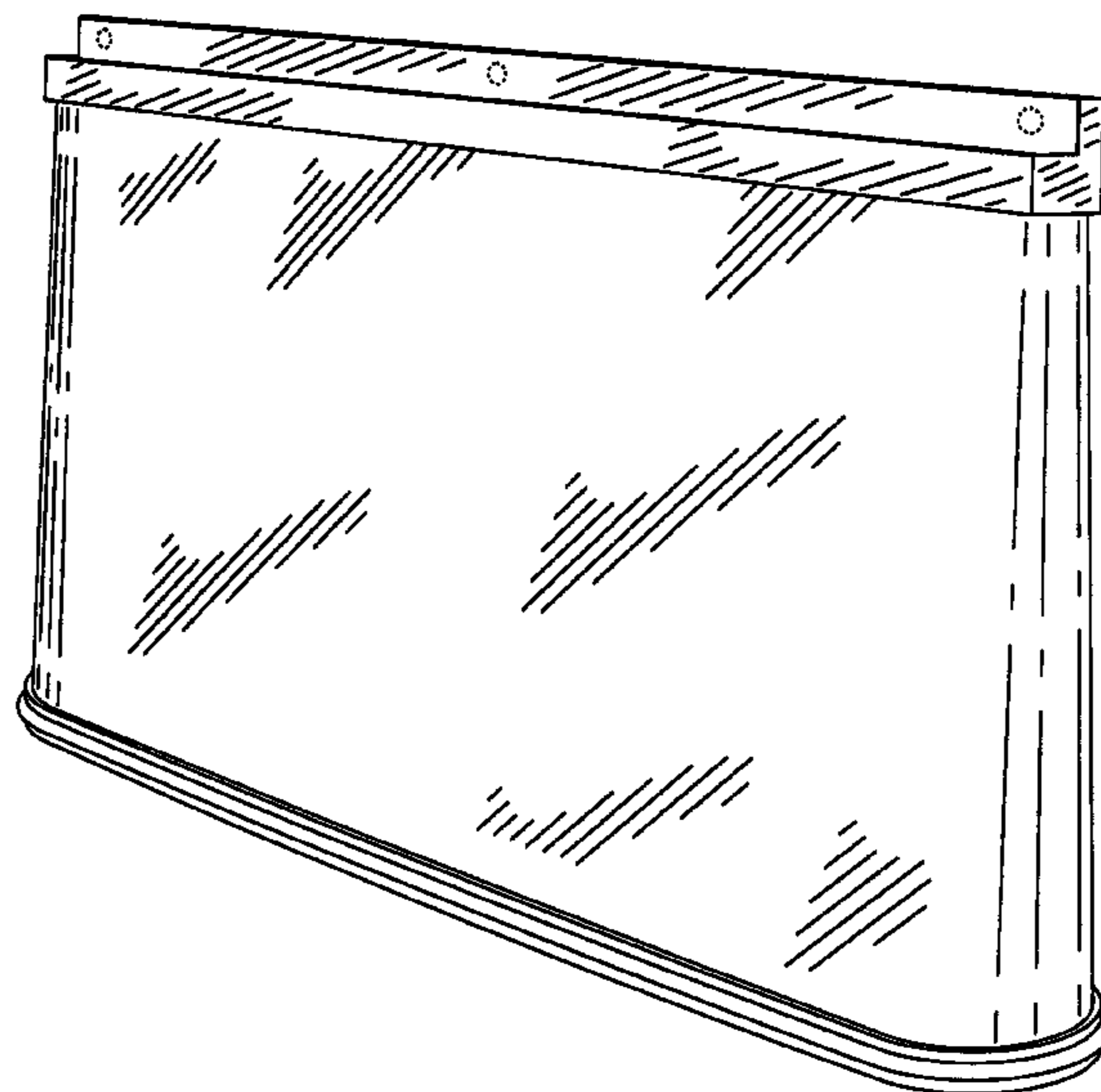

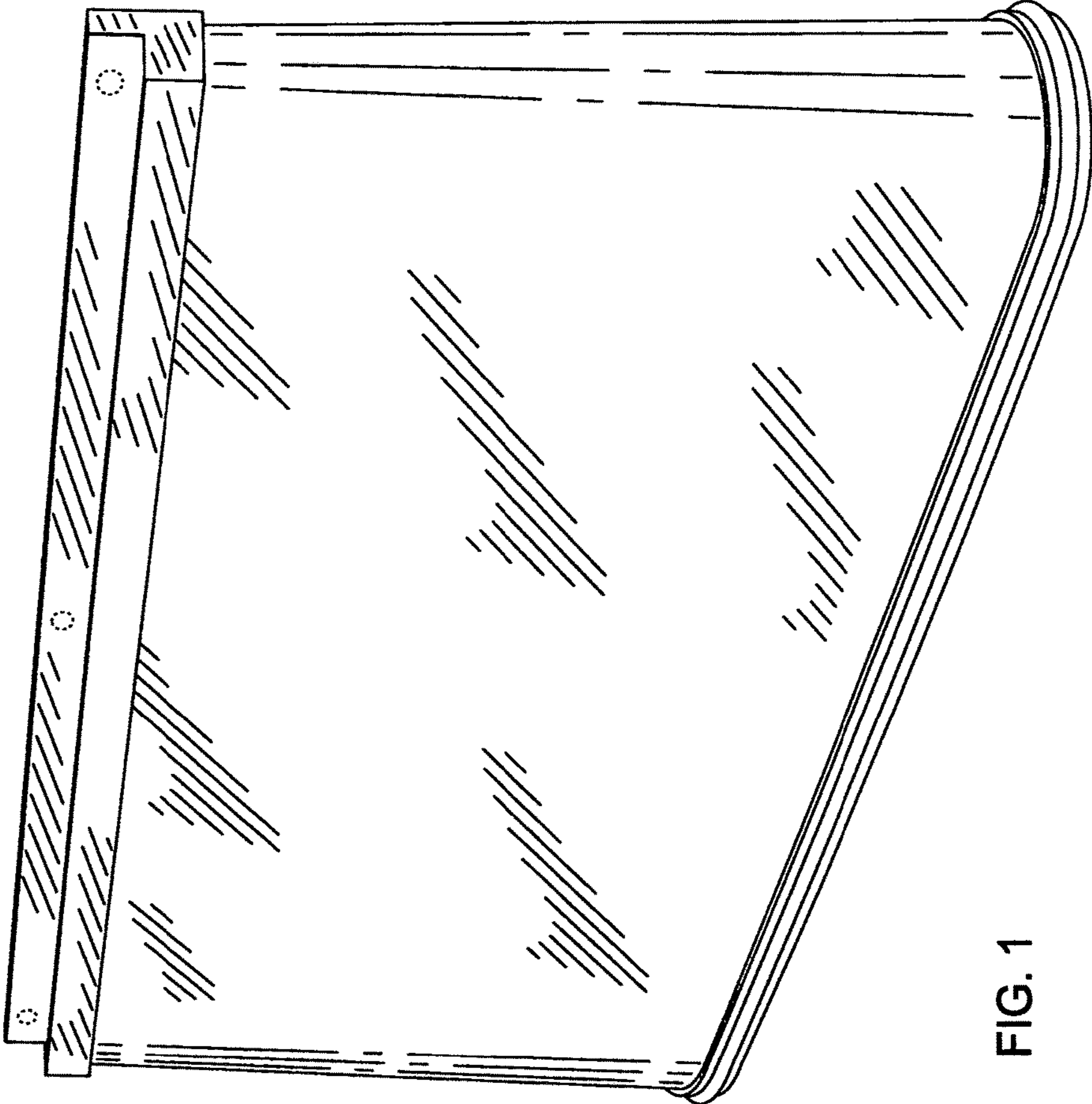

FIG. 1

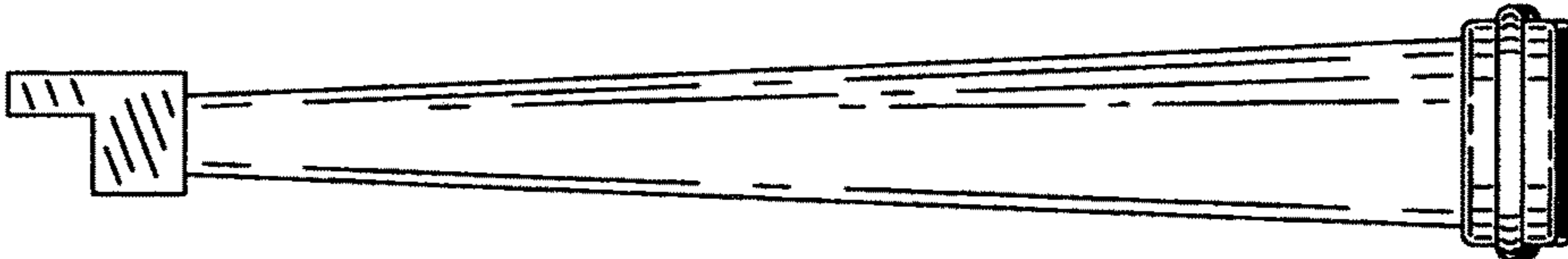

FIG. 2

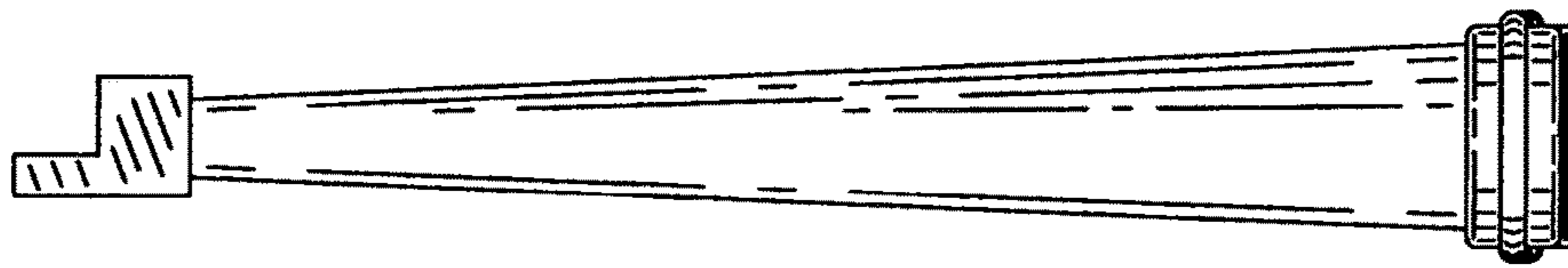

FIG. 3

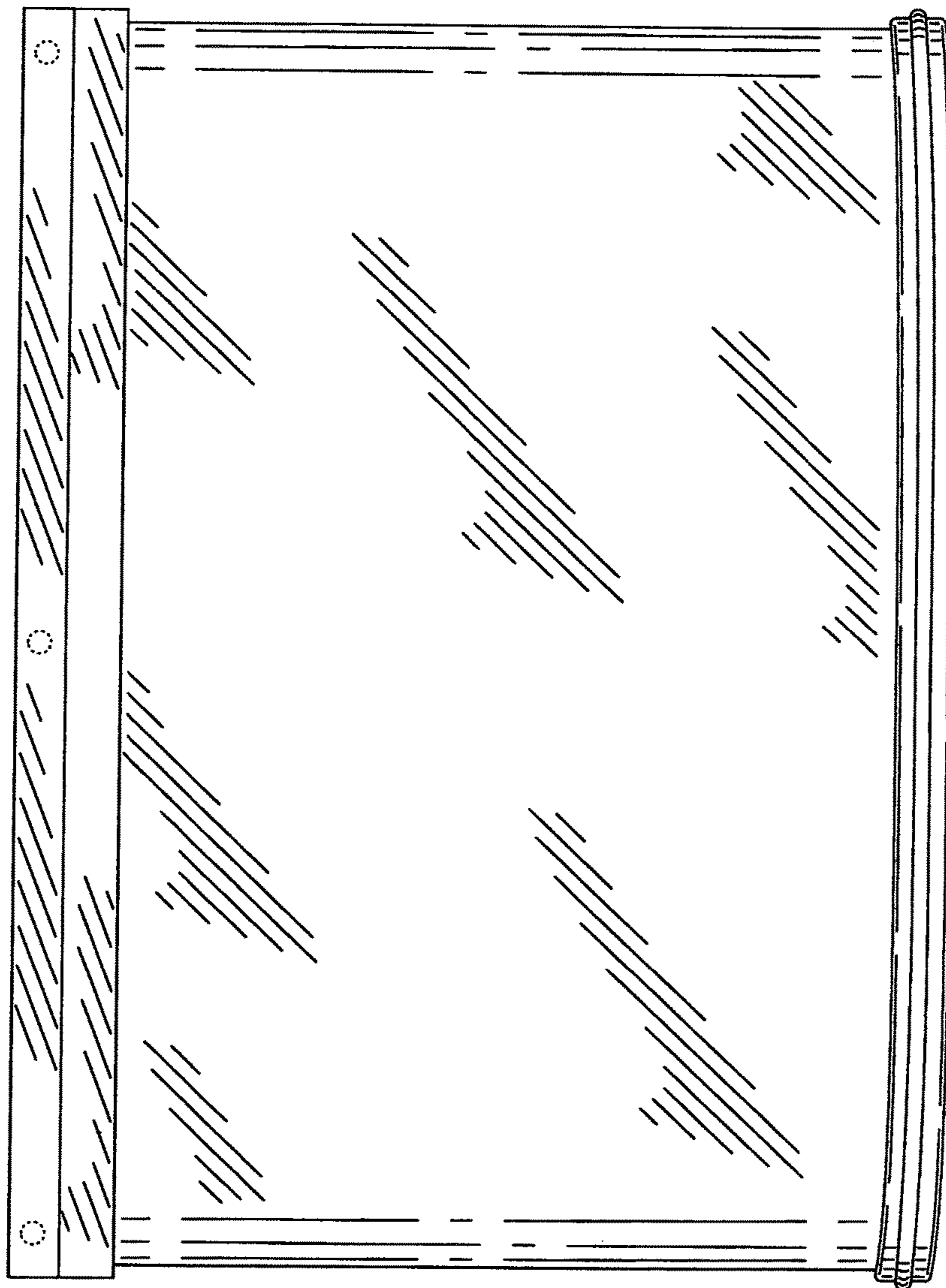

FIG. 4

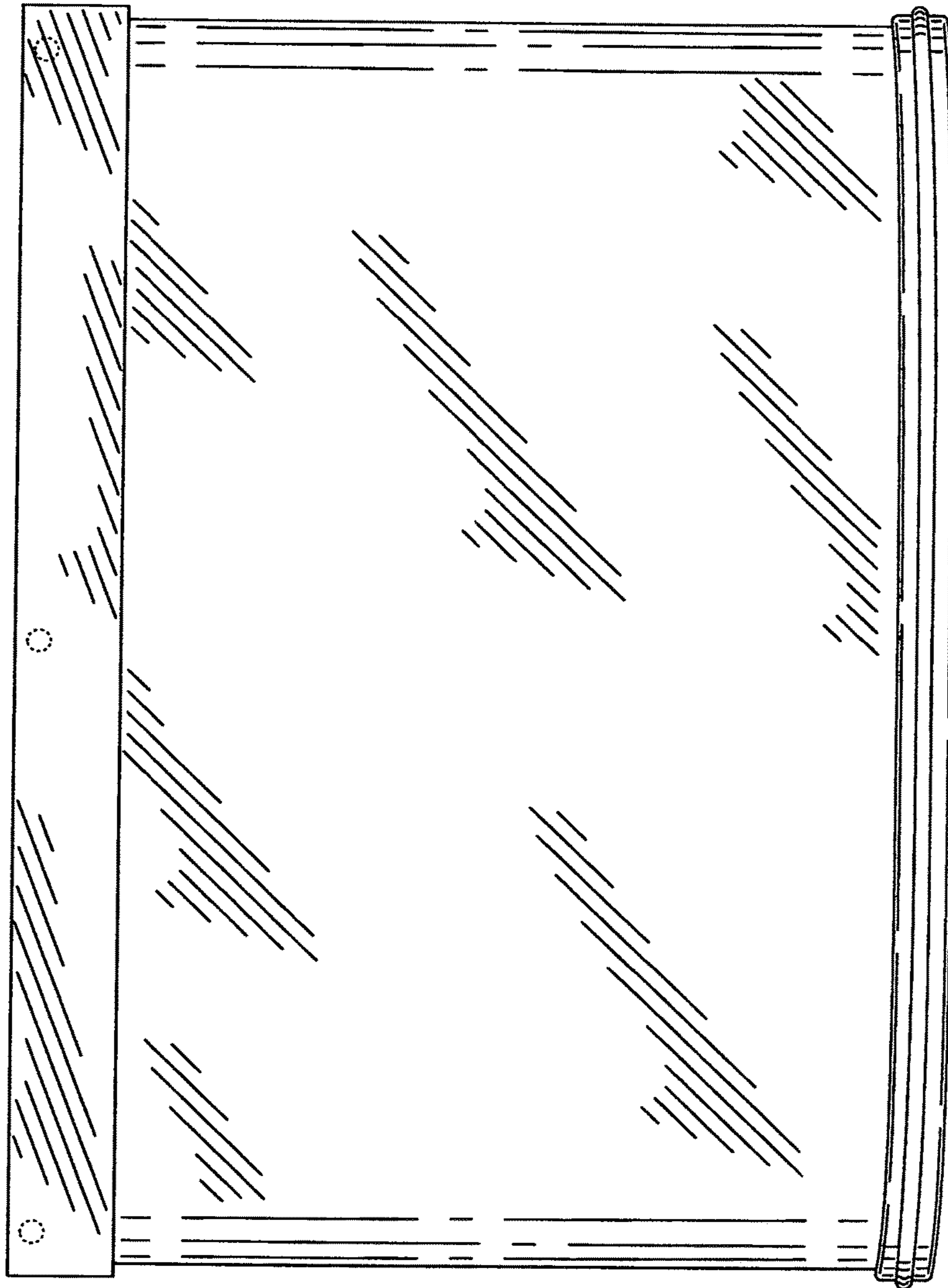

FIG. 5



FIG. 6

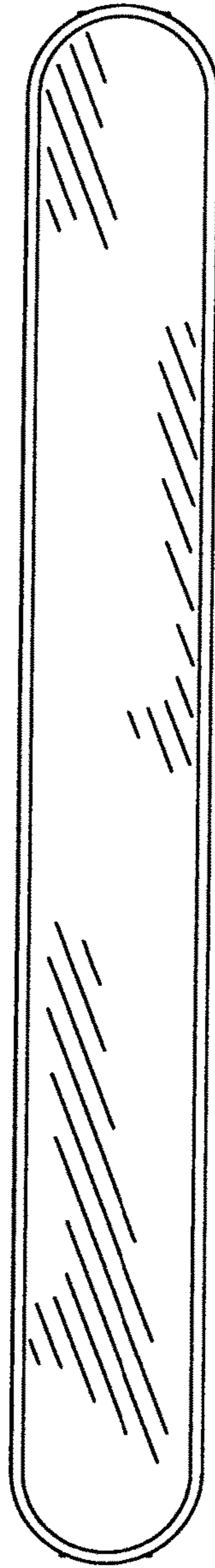

FIG. 7

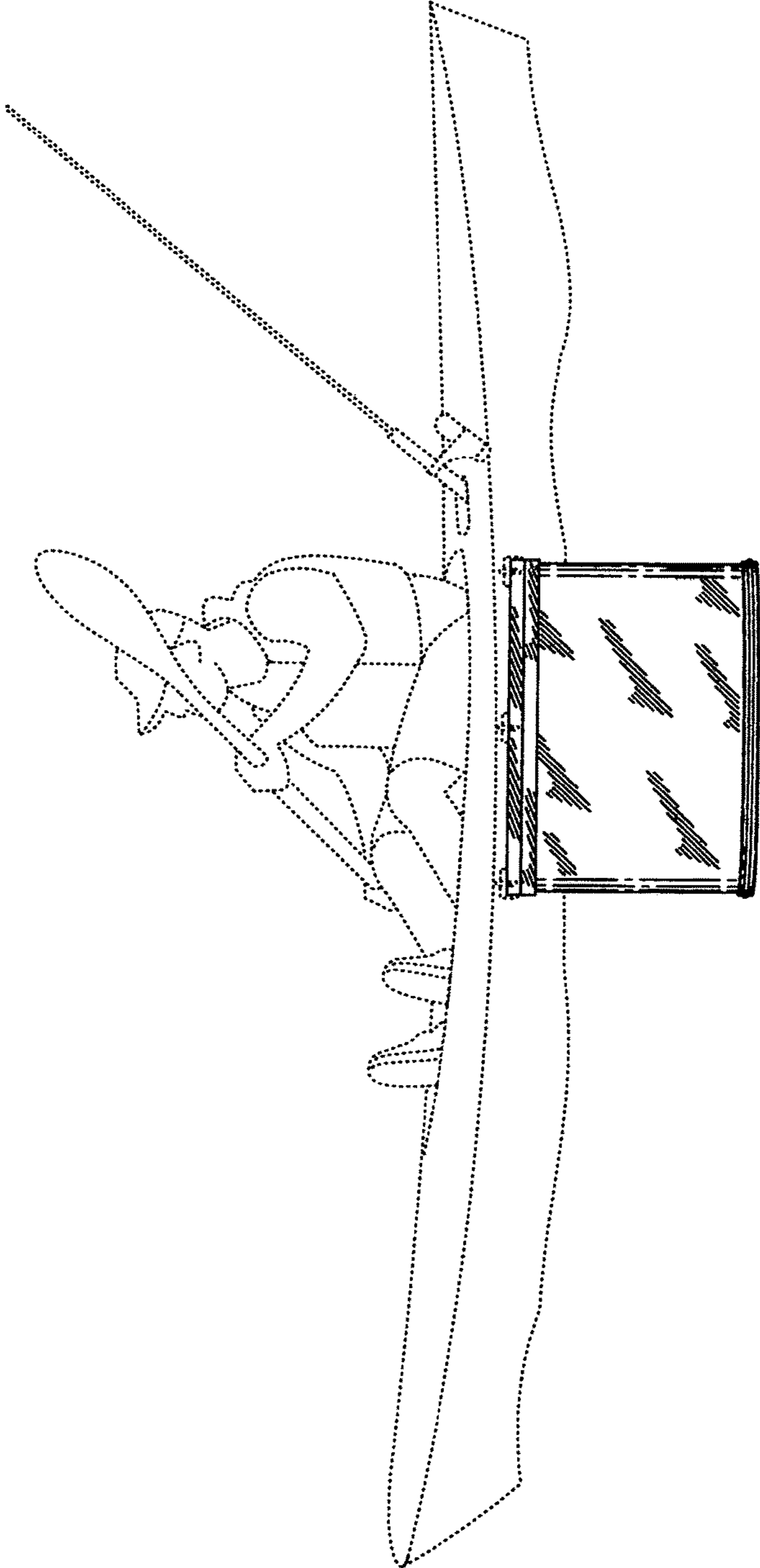

FIG. 8