



US00D843869S

(12) **United States Design Patent**
Kale et al.

(10) **Patent No.:** **US D843,869 S**
(45) **Date of Patent:** **** Mar. 26, 2019**

(54) **CONTROL UNIT AND VISUAL DISPLAY FOR A PORTABLE RACE CAR SIGNAL**

(71) Applicants: **Kenneth Kale**, Harveys Lake, PA (US);
Gary A. Cortese, Pottsville, PA (US)

(72) Inventors: **Kenneth Kale**, Harveys Lake, PA (US);
Gary A. Cortese, Pottsville, PA (US)

(**) Term: **15 Years**

(21) Appl. No.: **29/601,031**

(22) Filed: **Apr. 18, 2017**

(51) **LOC (11) Cl.** **10-05**

(52) **U.S. Cl.**
USPC **D10/109.1**

(58) **Field of Classification Search**
USPC D10/109.1, 109.2, 113.4
See application file for complete search history.

(56) **References Cited**

U.S. PATENT DOCUMENTS

2,854,650 A 9/1958 Baker et al.
3,683,330 A 8/1972 Lancaster

(Continued)

Primary Examiner — George D. Kirschbaum
(74) *Attorney, Agent, or Firm* — Woods Oviatt Gilman
LLP; Katherine H. McGuire, Esq.

(57) **CLAIM**

The ornamental design for a control unit and visual display for a portable race car signal, as shown and described.

DESCRIPTION

FIG. 1 is an enlarged perspective view of a single hand control unit of a control unit and visual display for a portable race car signal according to the invention;

FIG. 2 is a top plan view thereof;

FIG. 3 is a bottom plan view thereof;

FIG. 4 is a right side elevational view thereof;

FIG. 5 is a left side elevational view thereof;

FIG. 6 is a left end view thereof;

FIG. 7 is a right end view thereof;

FIG. 8 is a front plan view of two hand control units shown in FIGS. 1-7; the two units shown removably mounted to a vehicle steering wheel for the purpose of environment, the steering wheel is shown in broken lines form no part of the claimed design;

FIG. 9 is an enlarged front perspective view of a visual display of a control unit and visual display for a portable race car signal according to the invention;

FIG. 10 is a rear perspective view thereof, the broken lines showing a connector and fasteners for mounting the signaling unit on a vehicle for the purpose of environment, the broken lines form no part of the claimed design;

FIG. 11 is a front elevational view thereof shown in smaller scale, the broken lines showing a connector and fasteners for mounting the signaling unit on a vehicle for the purpose of environment, the broken lines form no part of the claimed design;

FIG. 12 is a rear elevational view thereof, the broken lines showing a connector and fasteners for mounting the signaling unit on a vehicle for the purpose of environment, the broken lines form no part of the claimed design;

FIG. 13 is a right end view thereof, the broken lines showing a connector and fasteners for mounting the signaling unit on a vehicle for the purpose of environment, the broken lines form no part of the claimed design;

FIG. 14 is a left end view thereof, the broken lines showing a connector and fasteners for mounting the signaling unit on a vehicle for the purpose of environment, the broken lines form no part of the claimed design;

FIG. 15 is a top plan view thereof, the broken lines showing a connector and fasteners for mounting the signaling unit on a vehicle for the purpose of environment, the broken lines form no part of the claimed design; and,

FIG. 16 is a bottom plan view thereof, the broken lines showing a connector and fasteners for mounting the signaling unit on a vehicle for the purpose of environment, the broken lines form no part of the claimed design.

The broken line showing of a steering wheel and a second control unit and visual display mounting hardware is

(Continued)

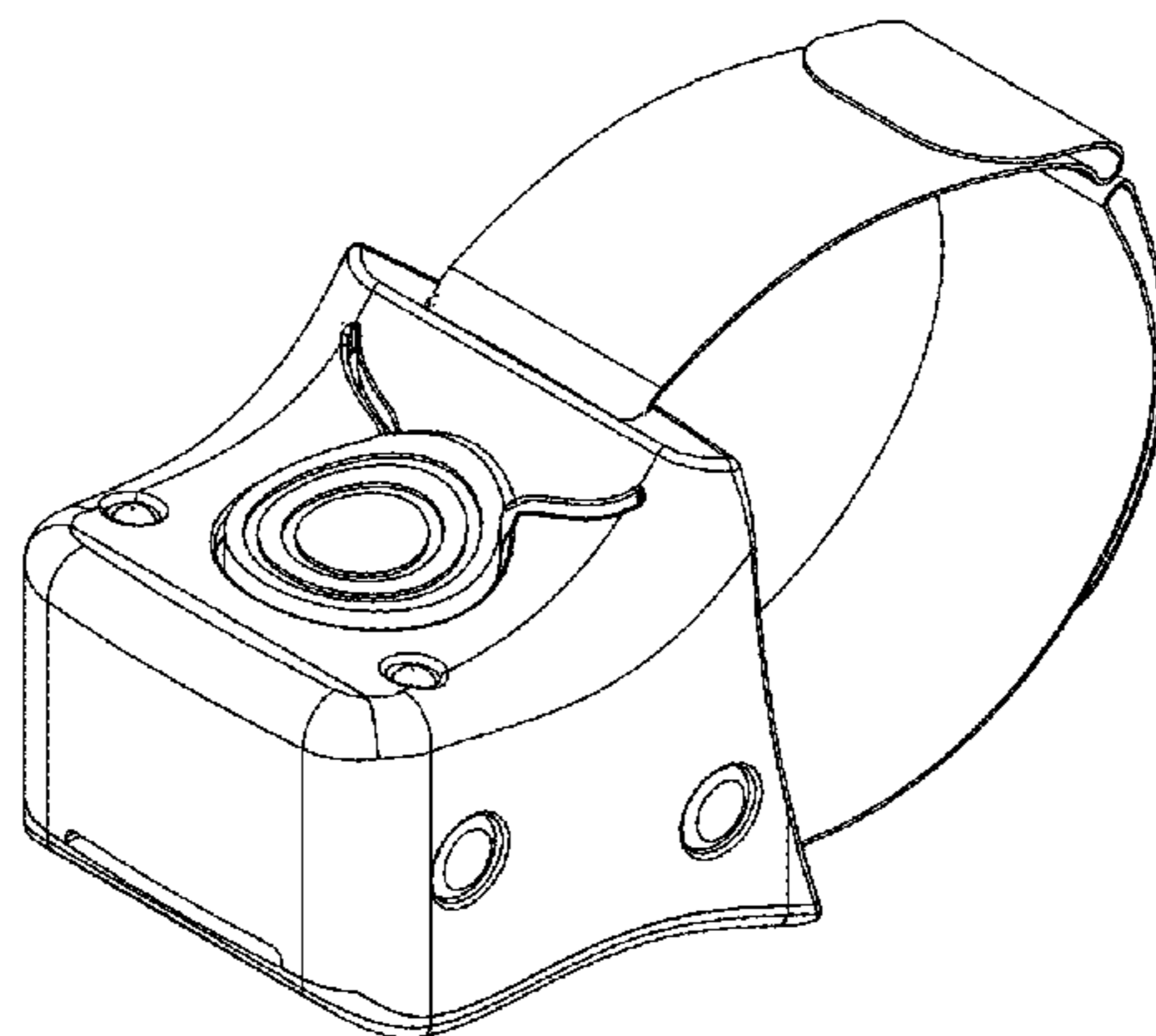

included for the purpose of illustrating portions of the article and forms no part of the claimed design.

1 Claim, 8 Drawing Sheets

(56) **References Cited**

U.S. PATENT DOCUMENTS

4,361,828	A	11/1982	Hose	
4,631,516	A	12/1986	Clinker	
D449,010	S *	10/2001	Petrucelli	D10/109.1
D454,807	S *	3/2002	Cappiello	D10/109.1
D463,749	S *	10/2002	Petrucelli	D10/109.1
6,850,209	B2	2/2005	Mankins et al.	
D539,686	S *	4/2007	Thibado	D10/109.1
7,659,808	B1	2/2010	Cooper et al.	
9,393,902	B2	7/2016	Le Sage et al.	
D776,553	S *	1/2017	Eloyan	D10/113.4
2005/0083183	A1	4/2005	Cao et al.	
2007/0030139	A1	2/2007	Ellison et al.	
2016/0067597	A1	3/2016	Hamilton	

* cited by examiner

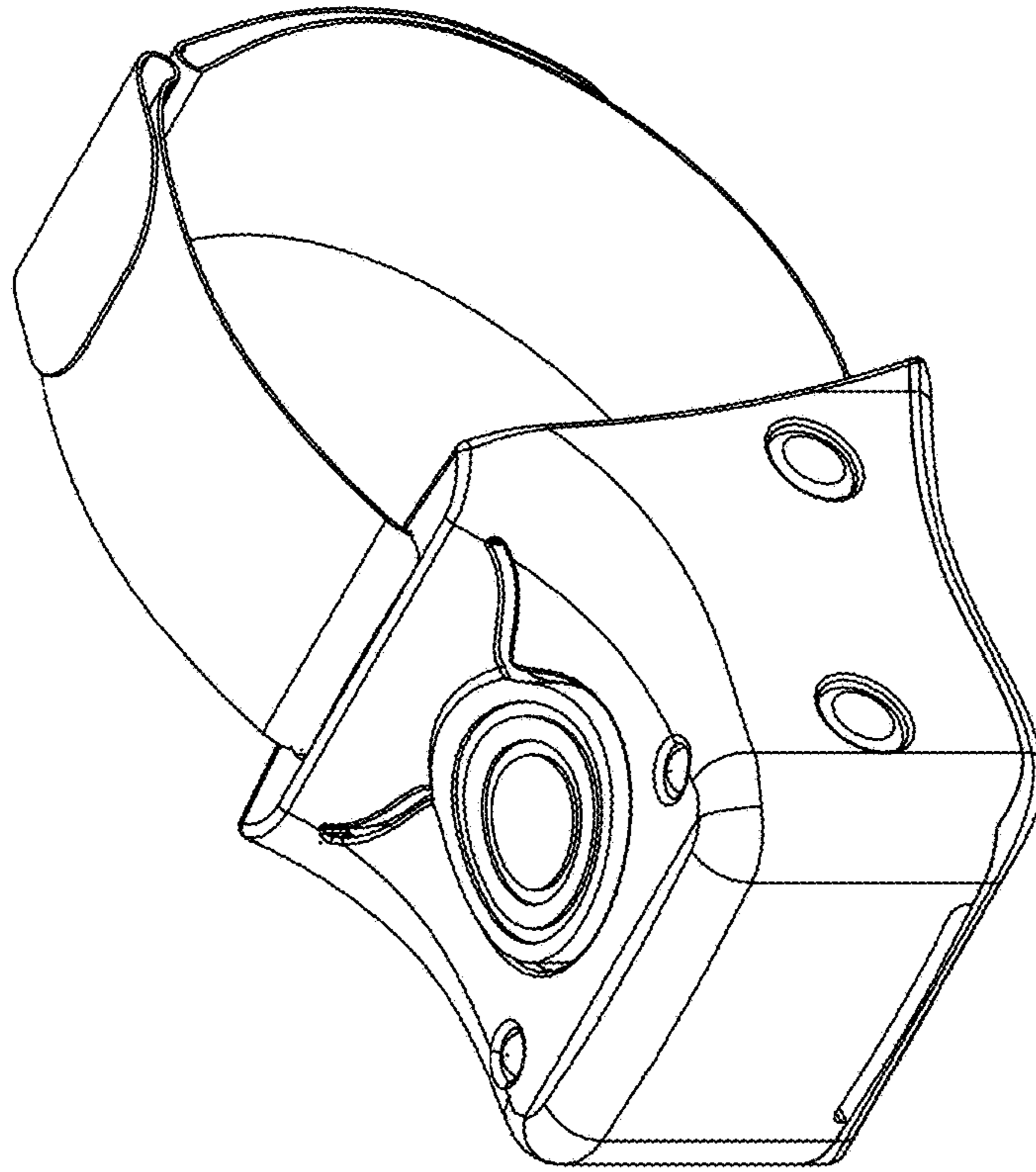

Fig. 1

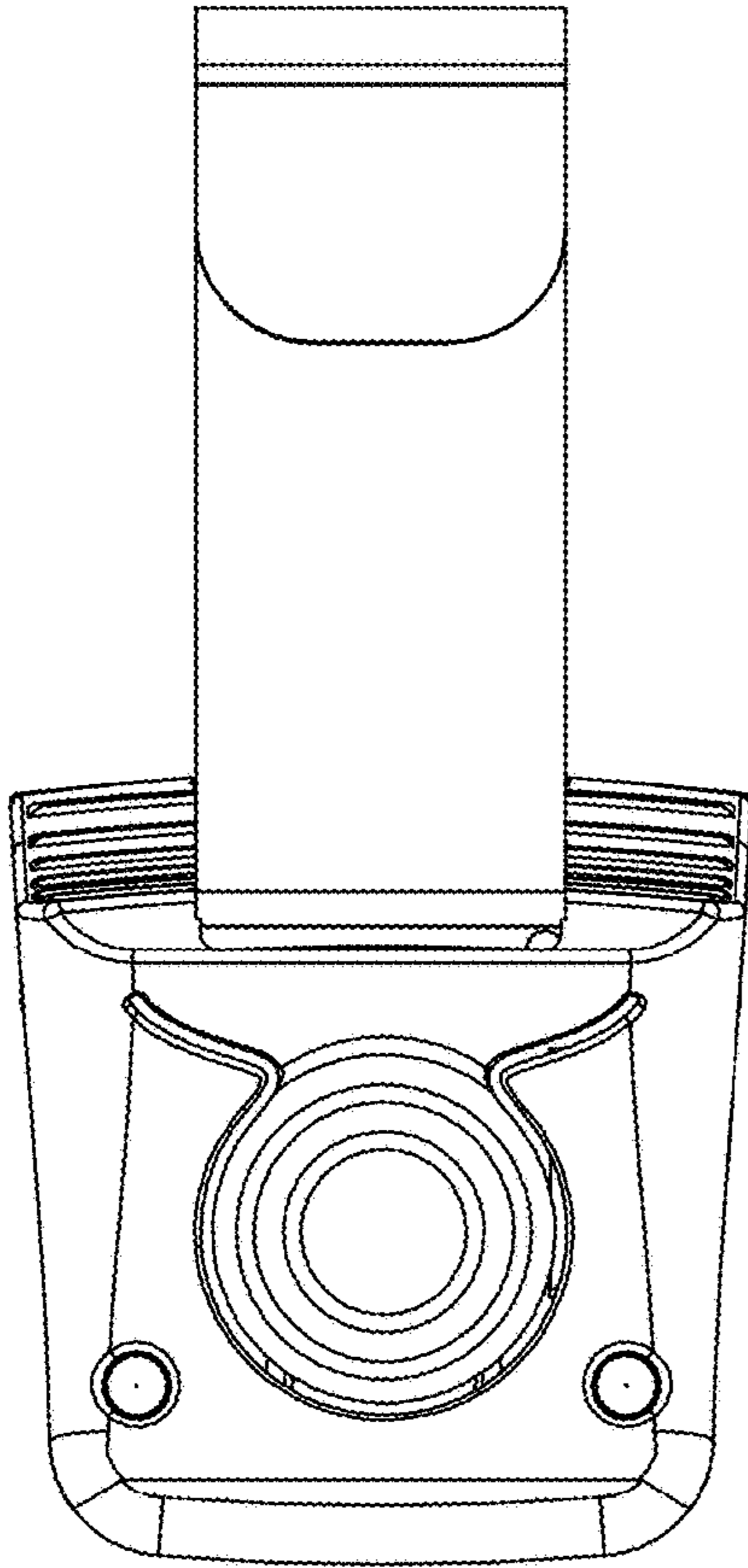

Fig. 2

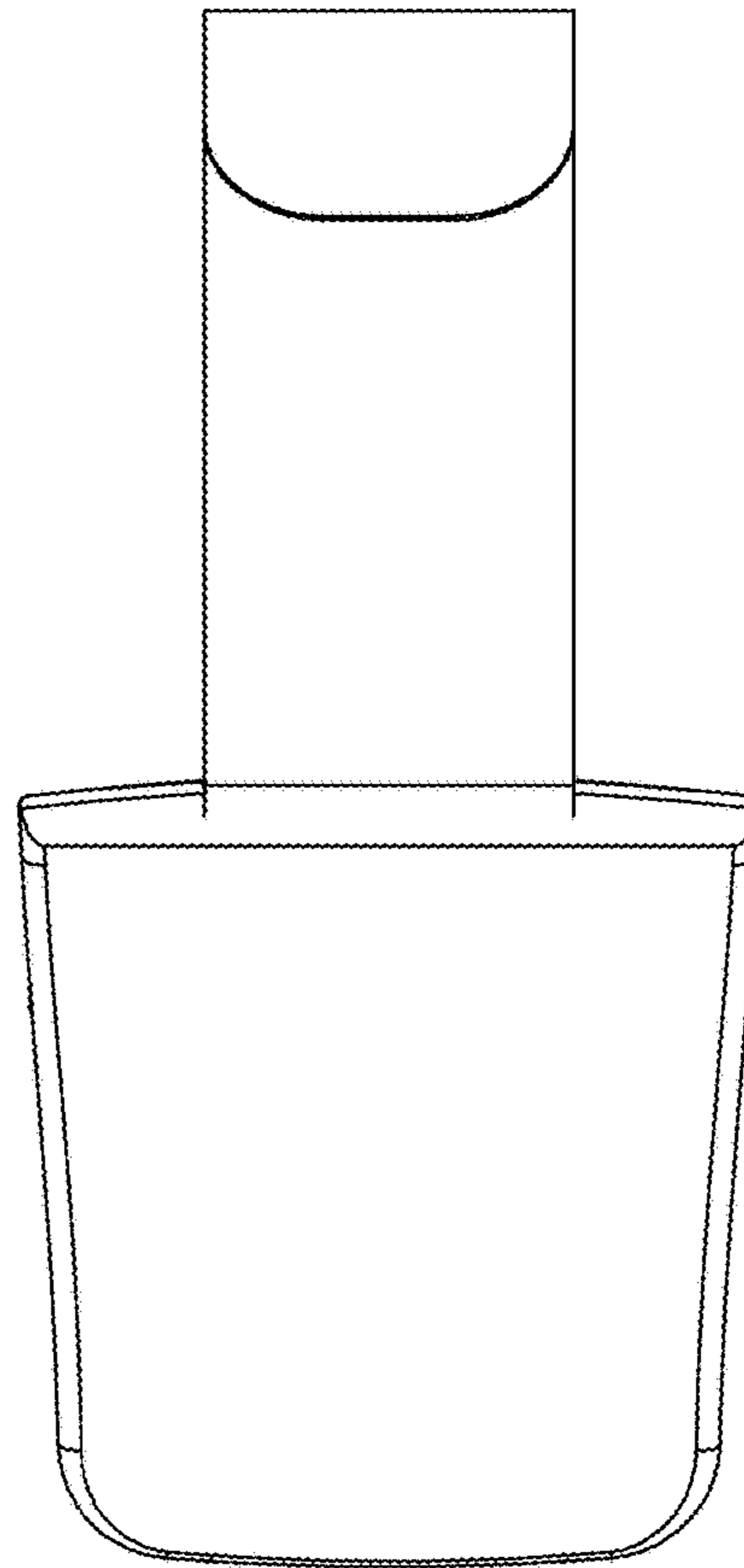

Fig. 3

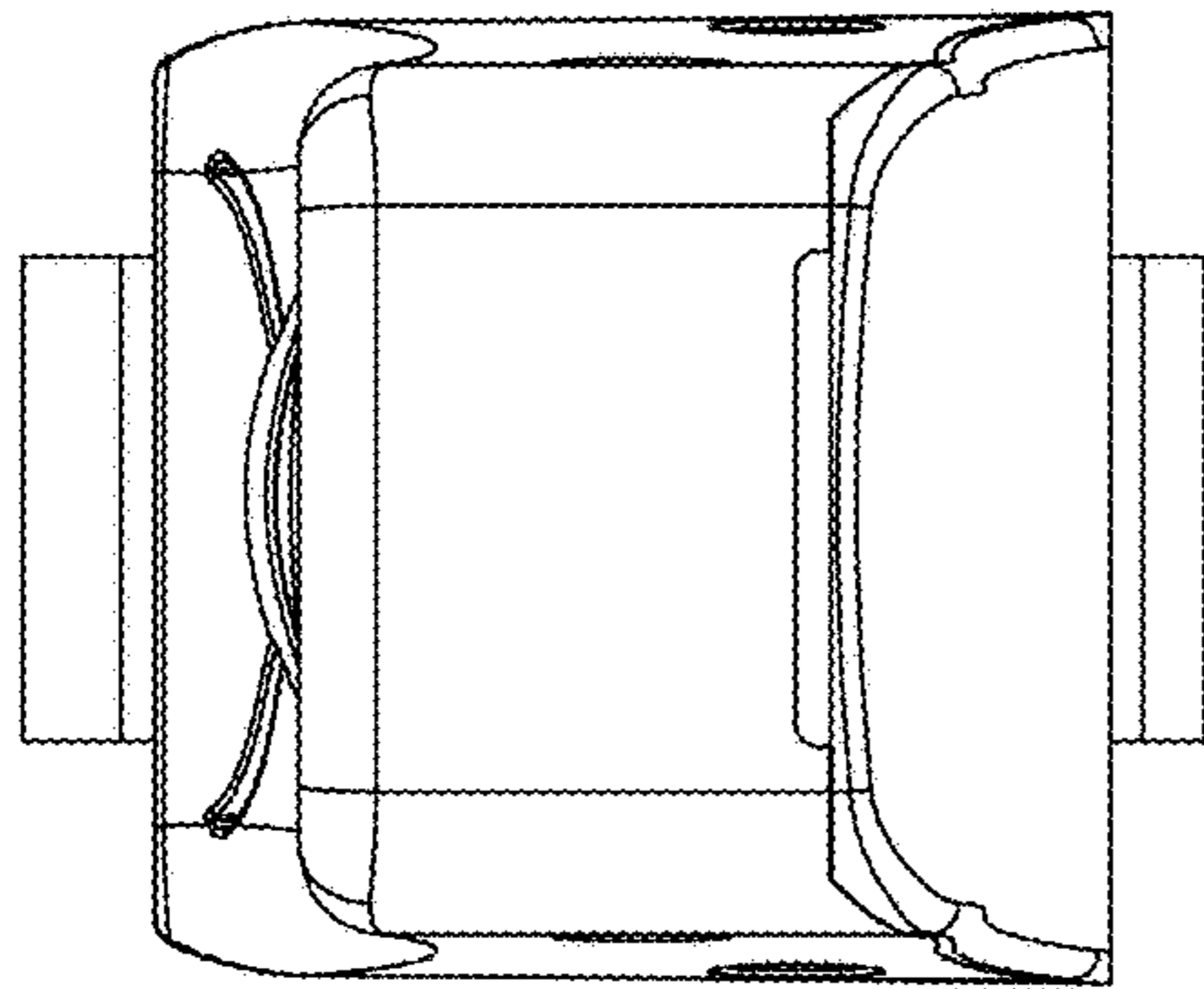

Fig. 6

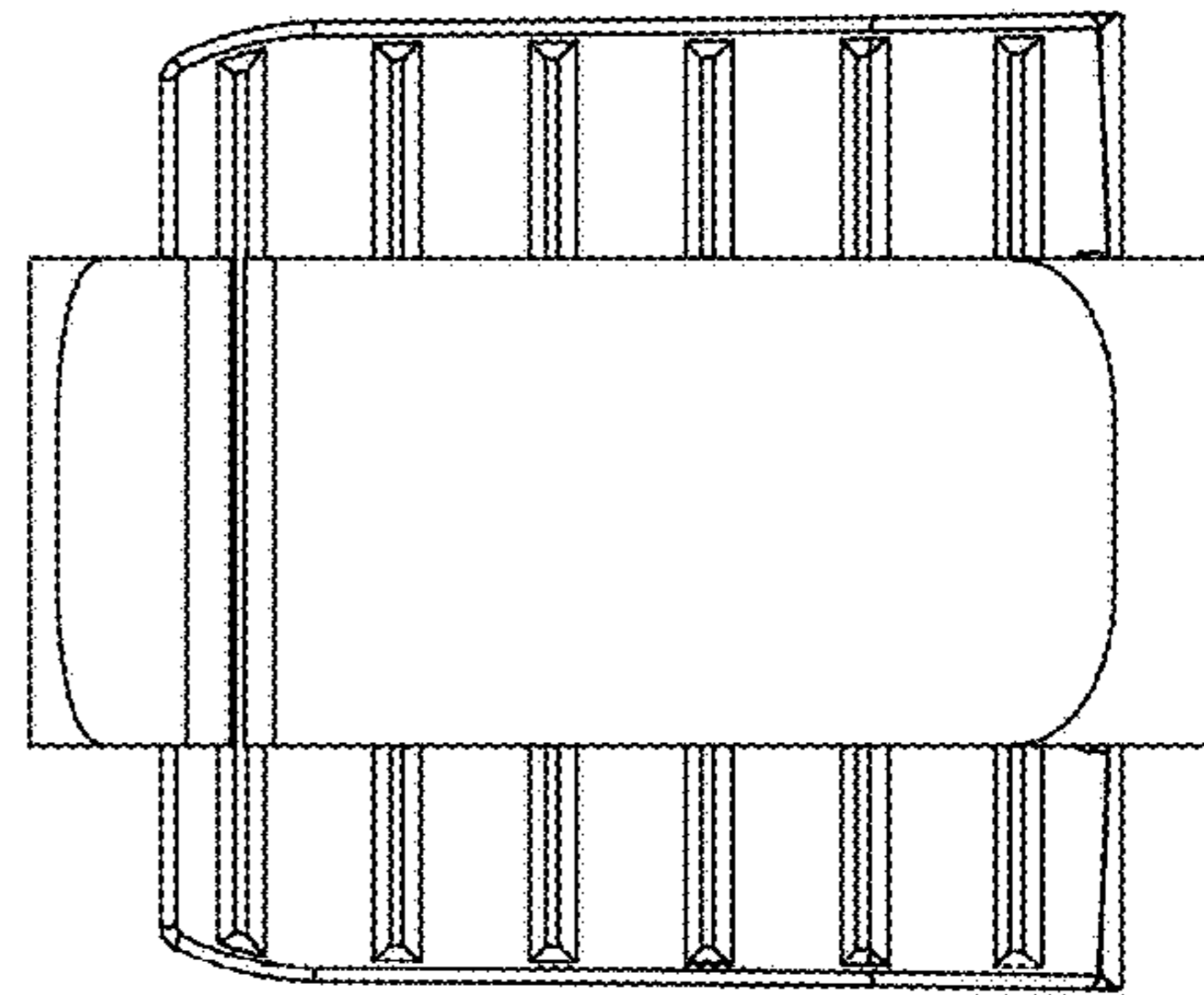

Fig. 7

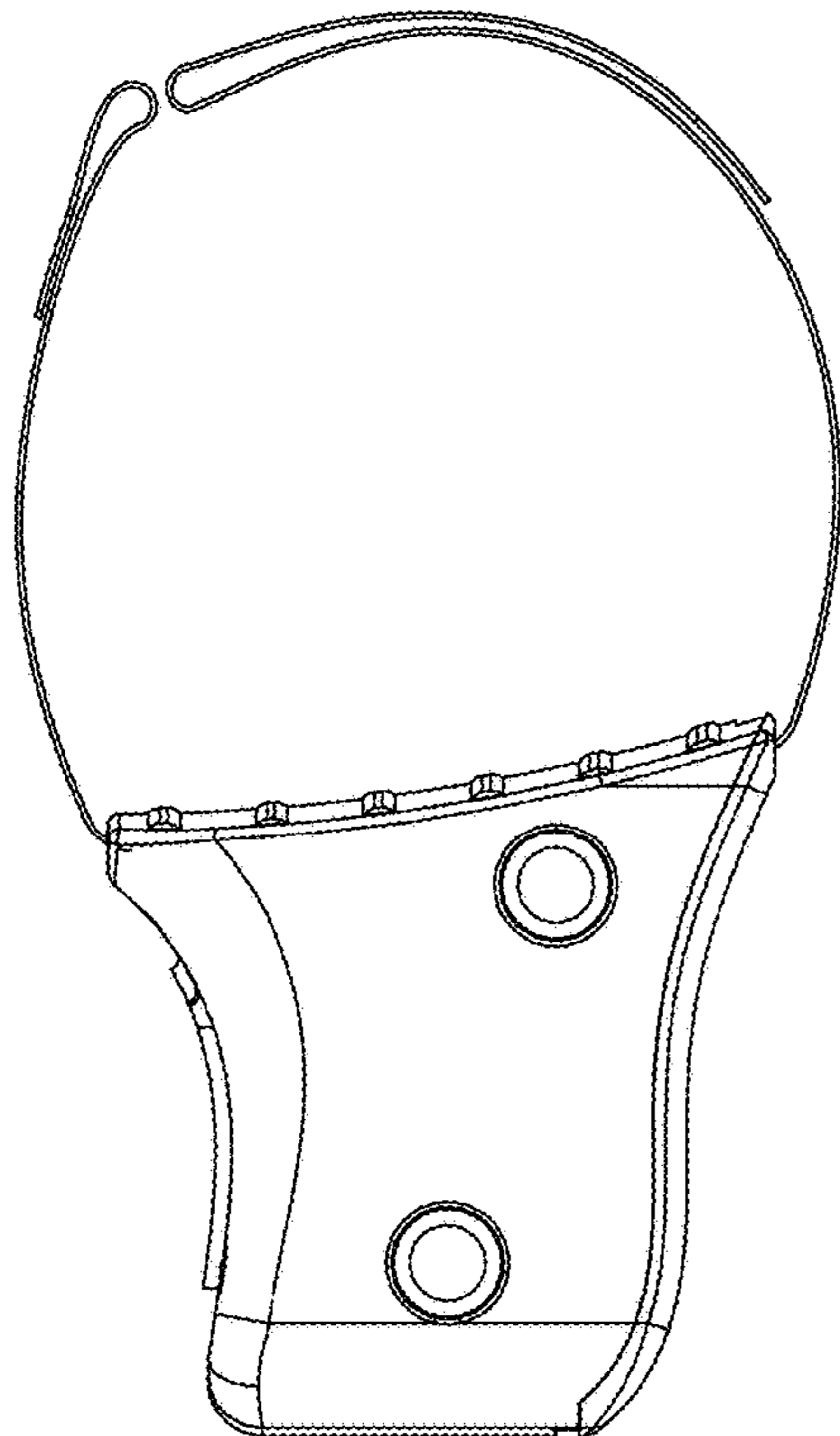

Fig. 4

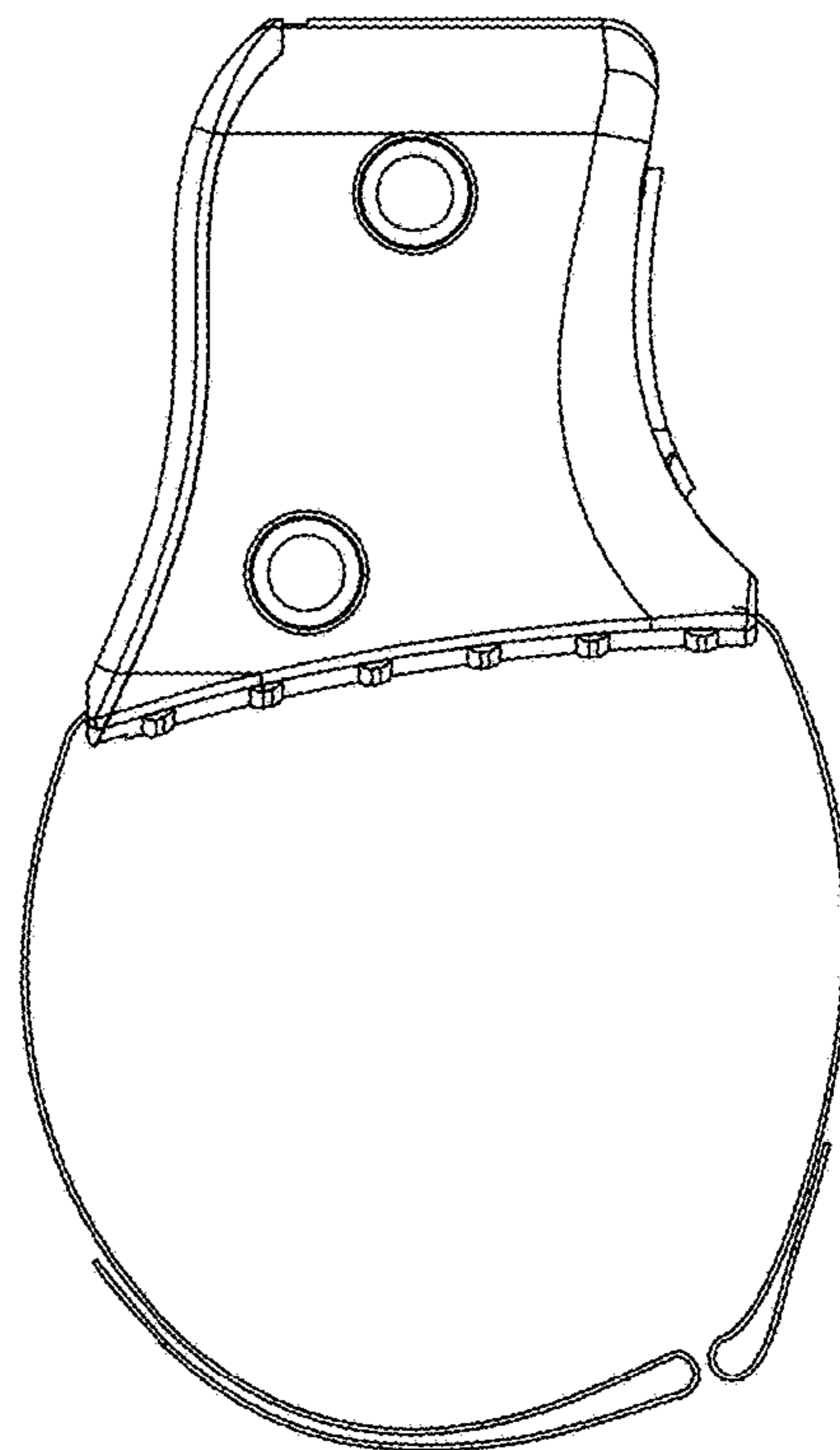

Fig. 5

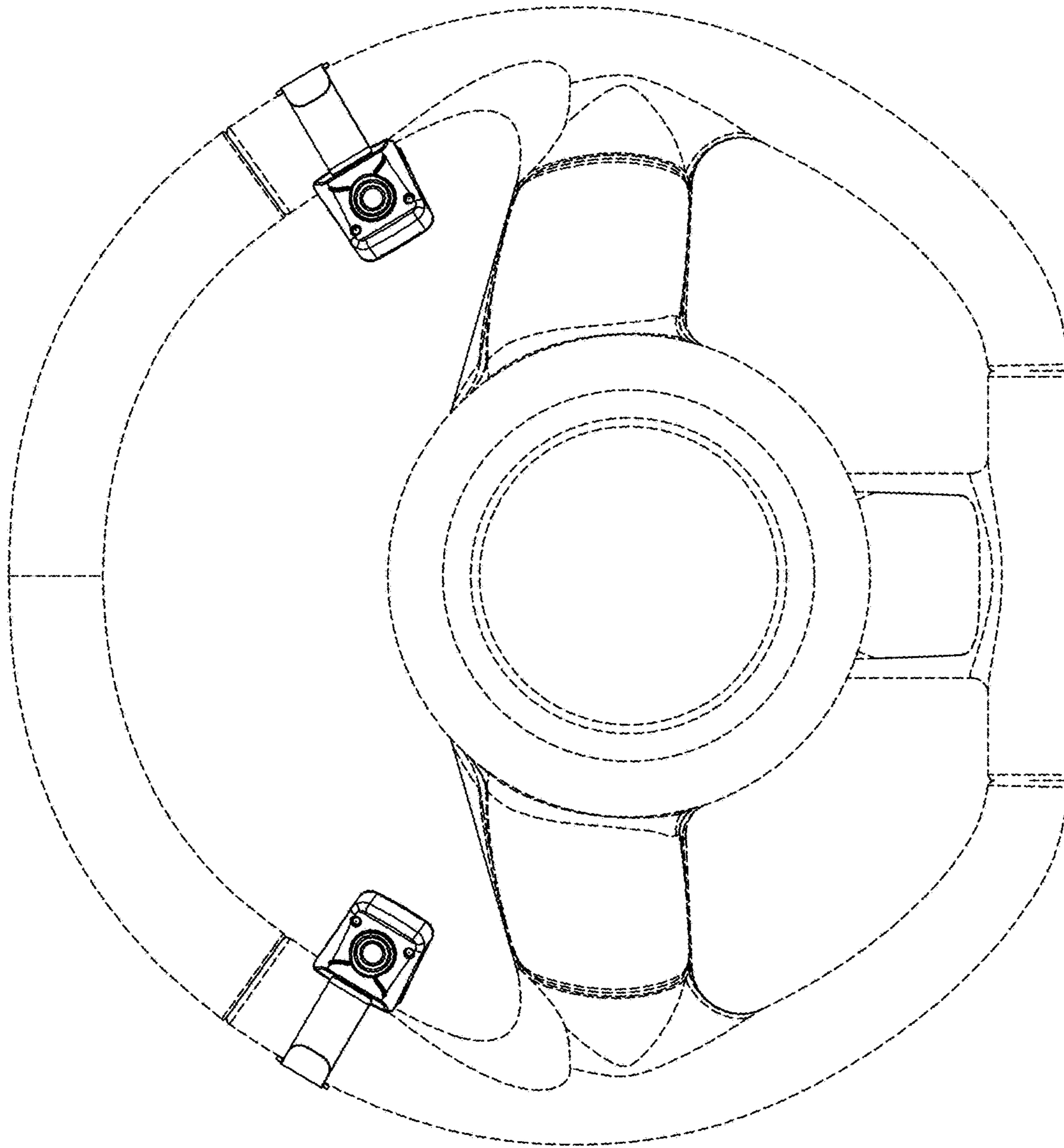

Fig. 8

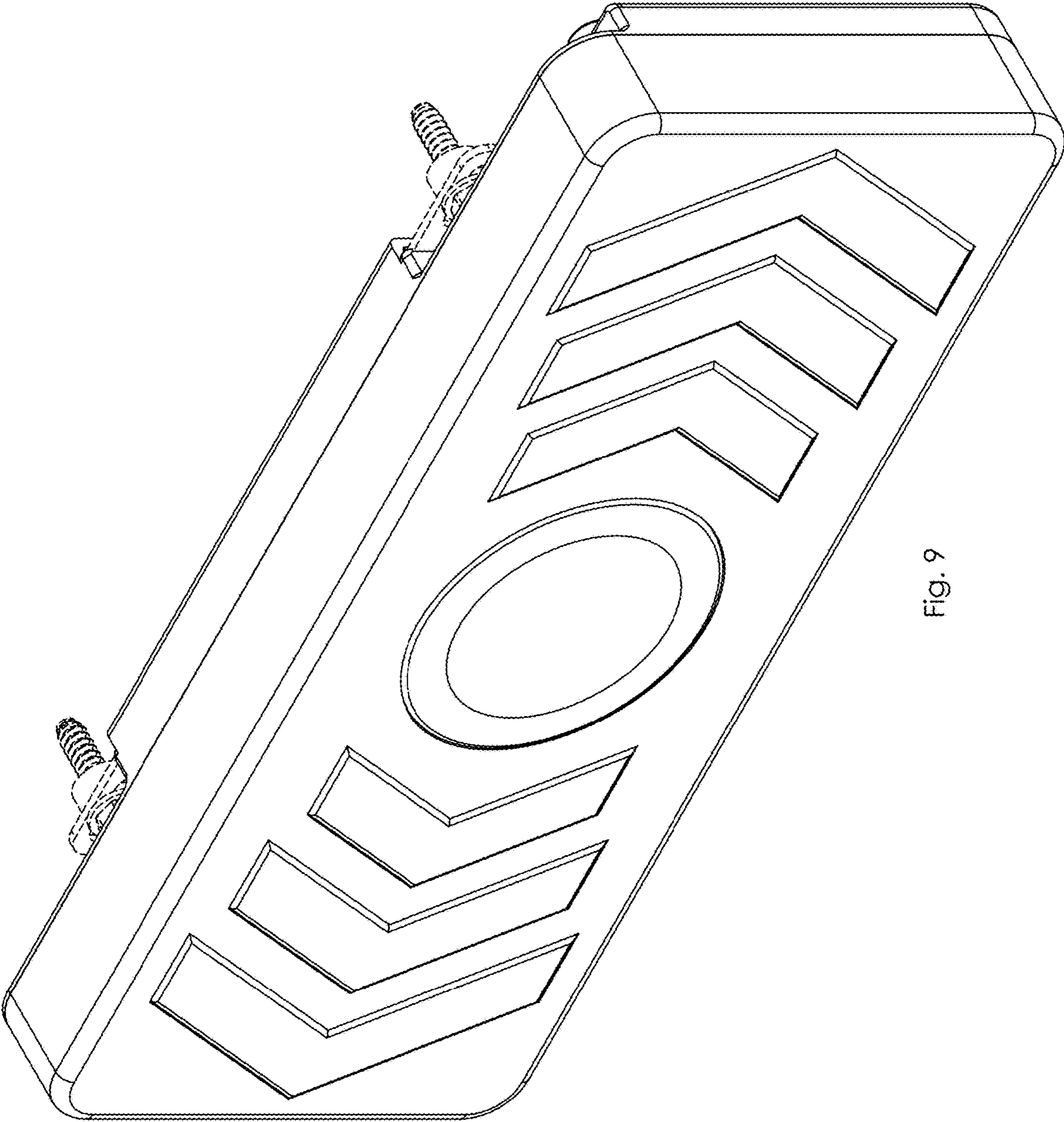

FIG. 9

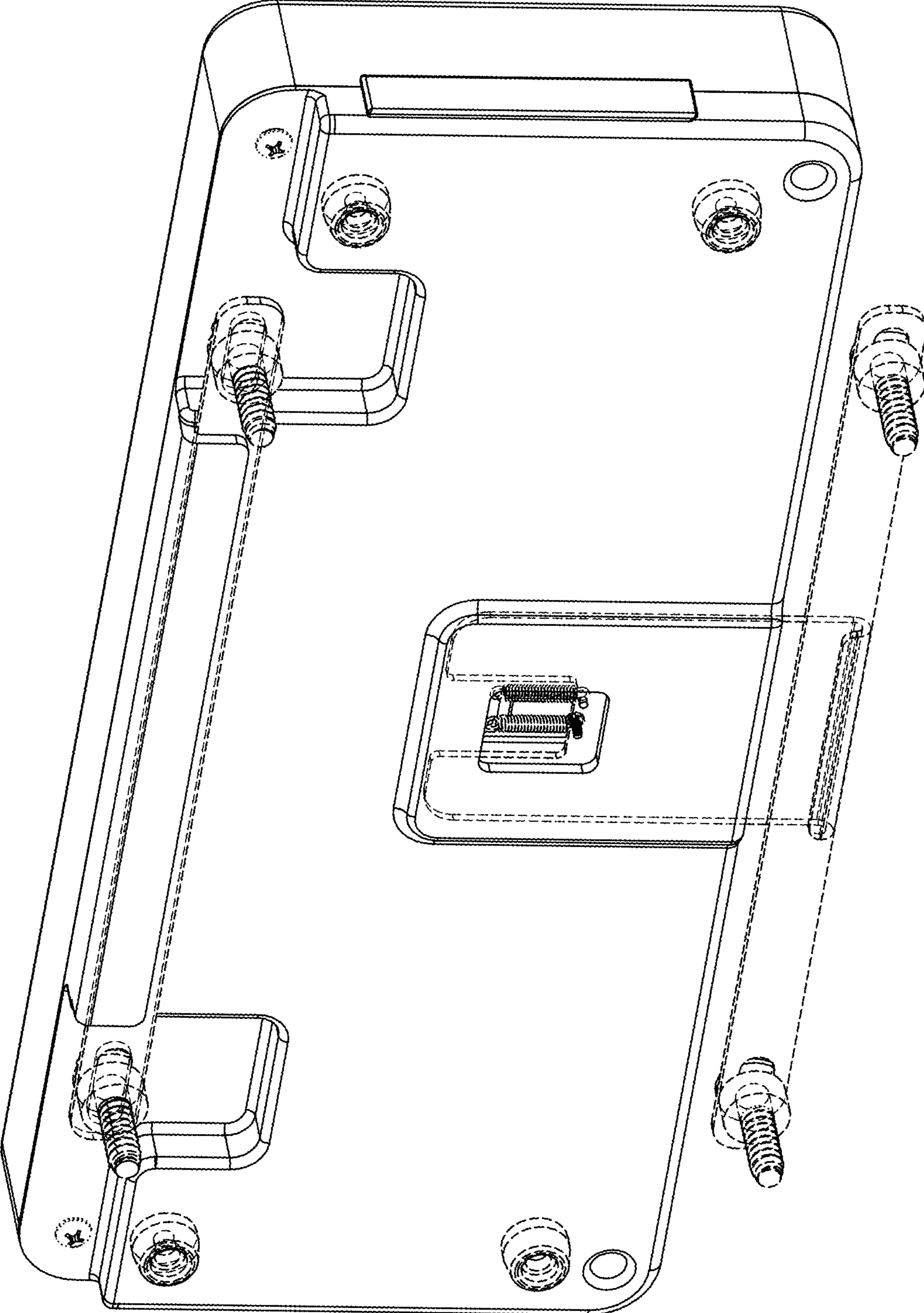

Fig. 10

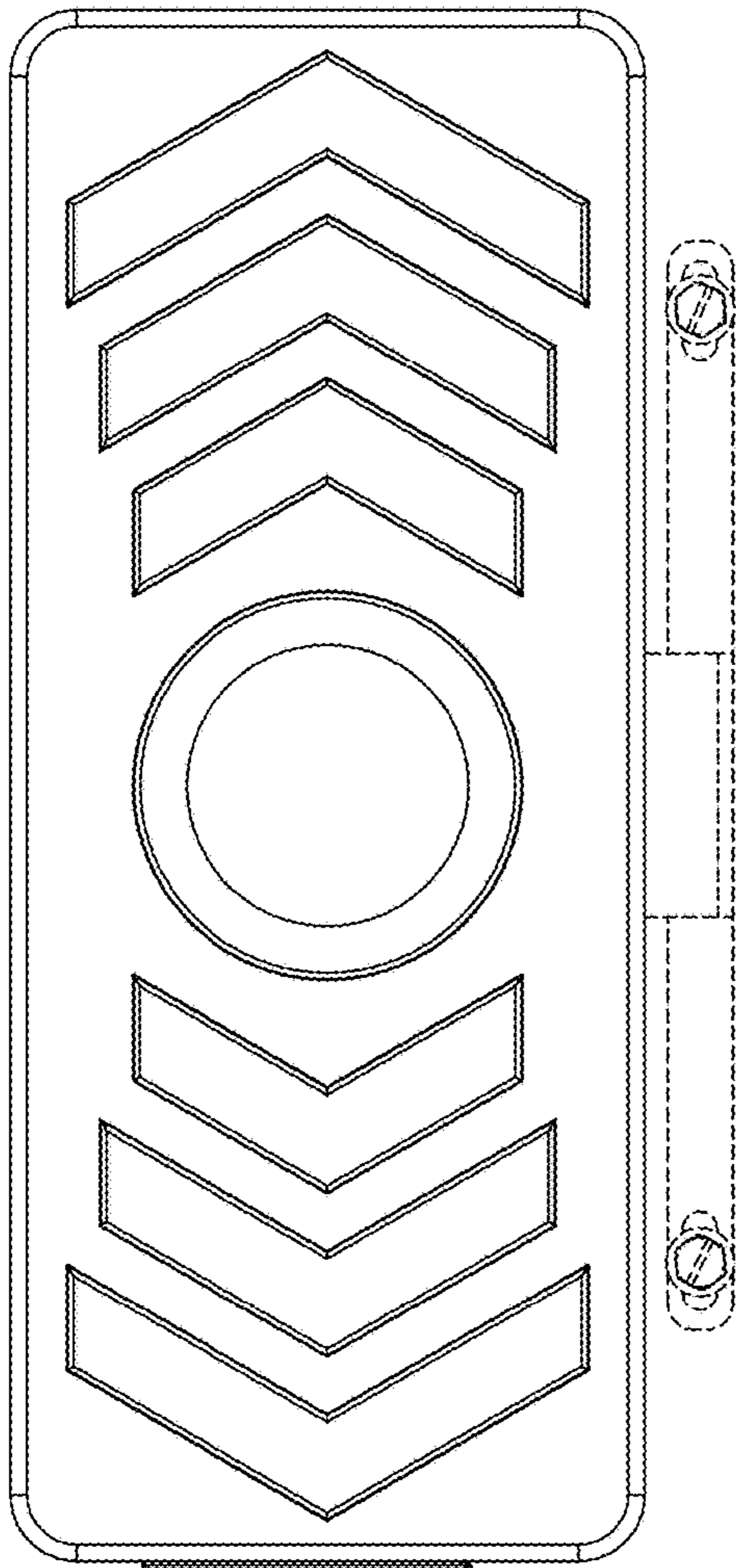

Fig. 11

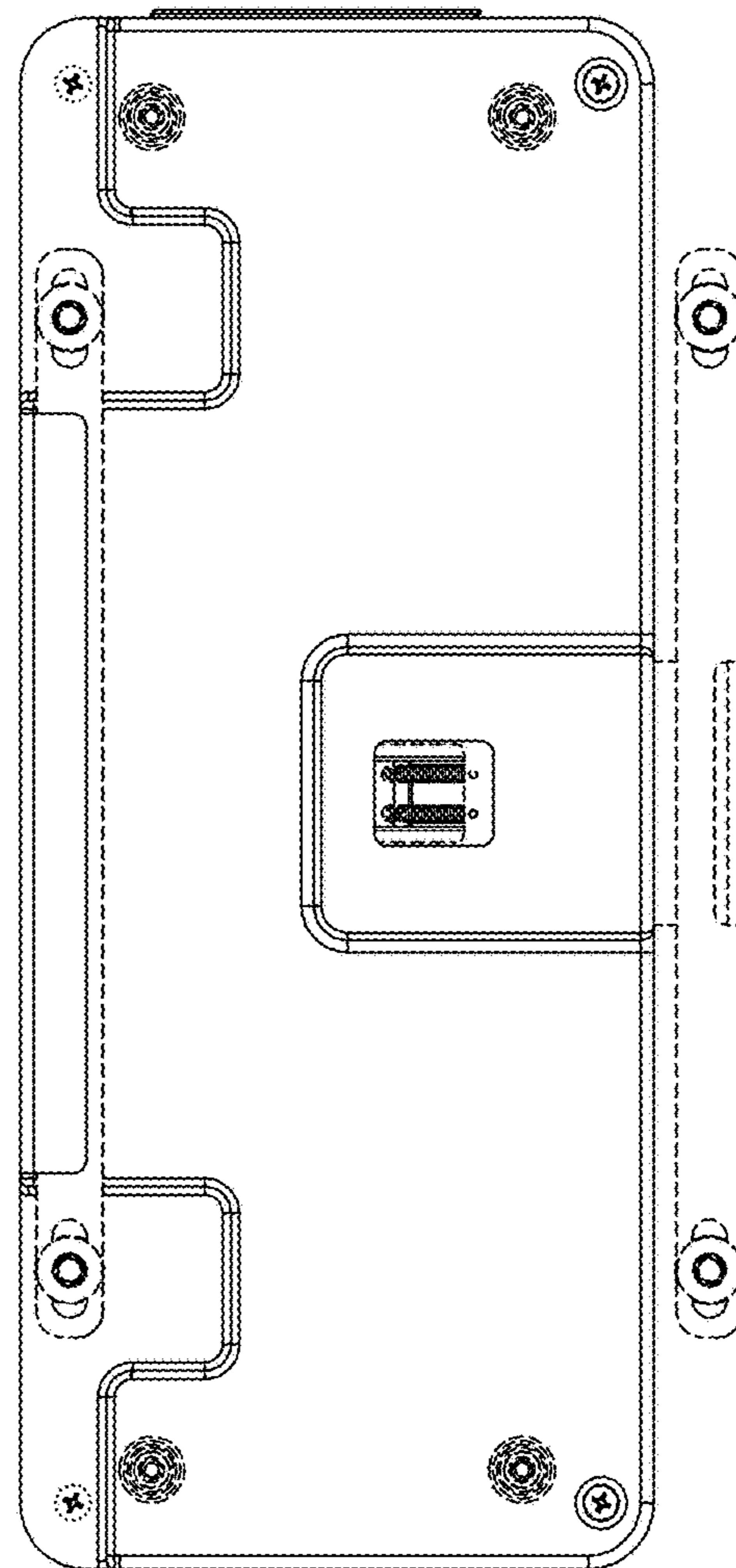

Fig. 12

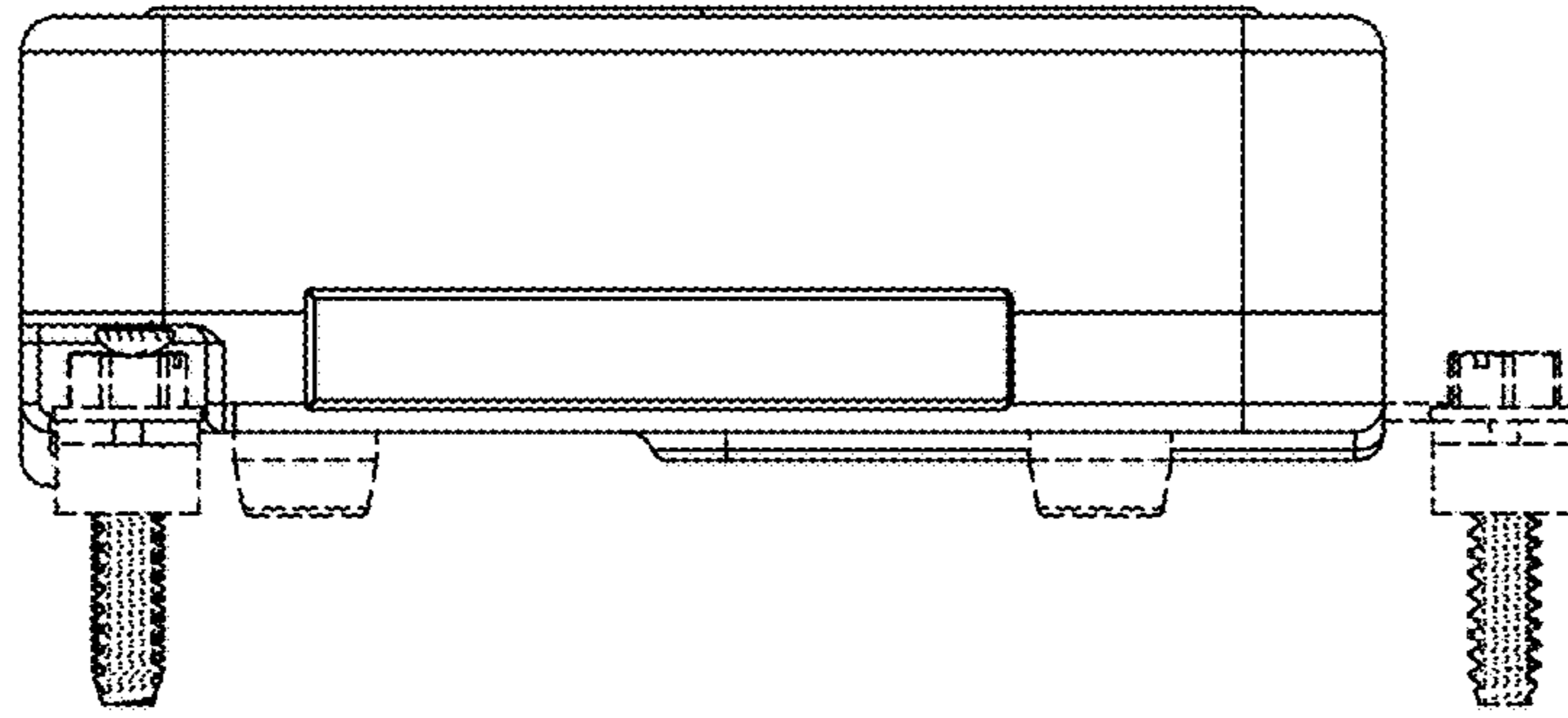

Fig. 14

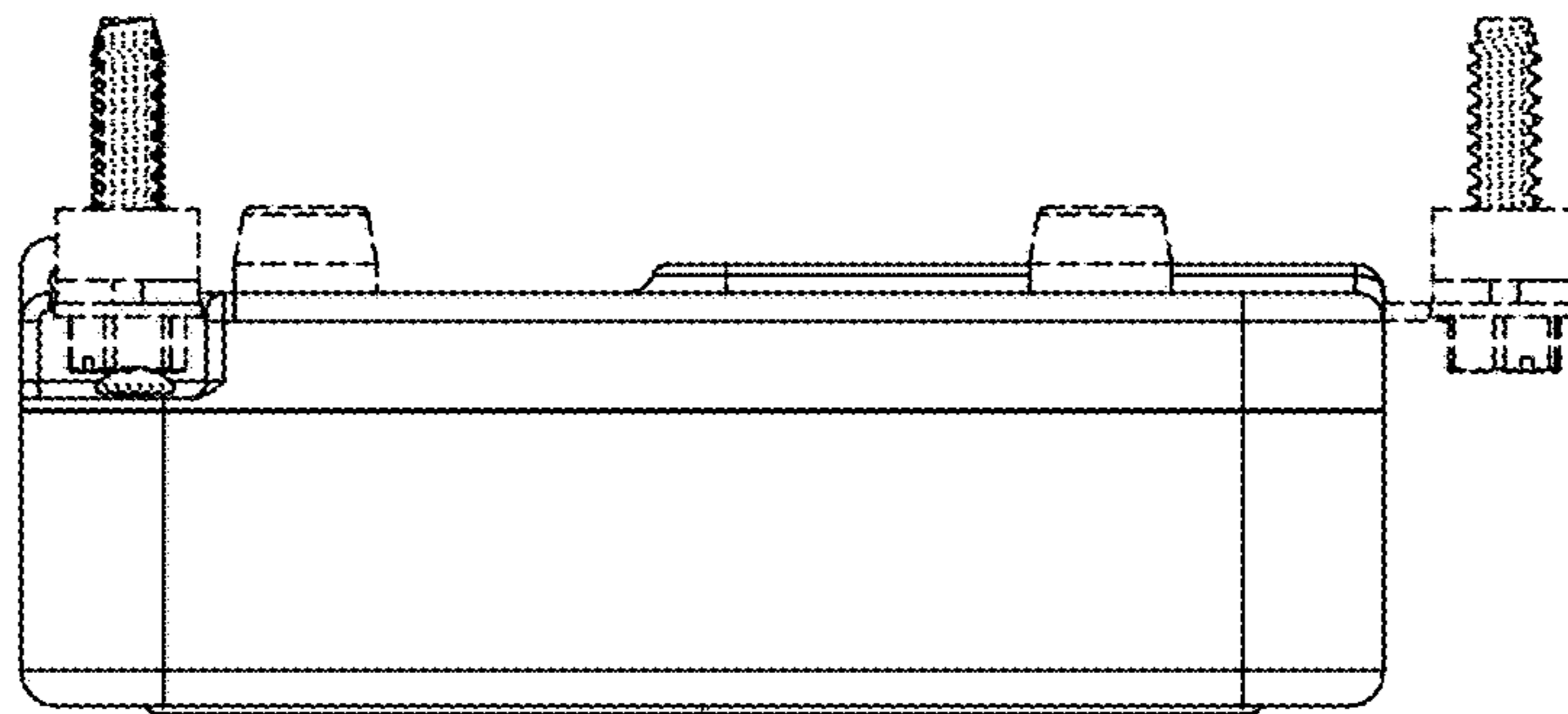

Fig. 13

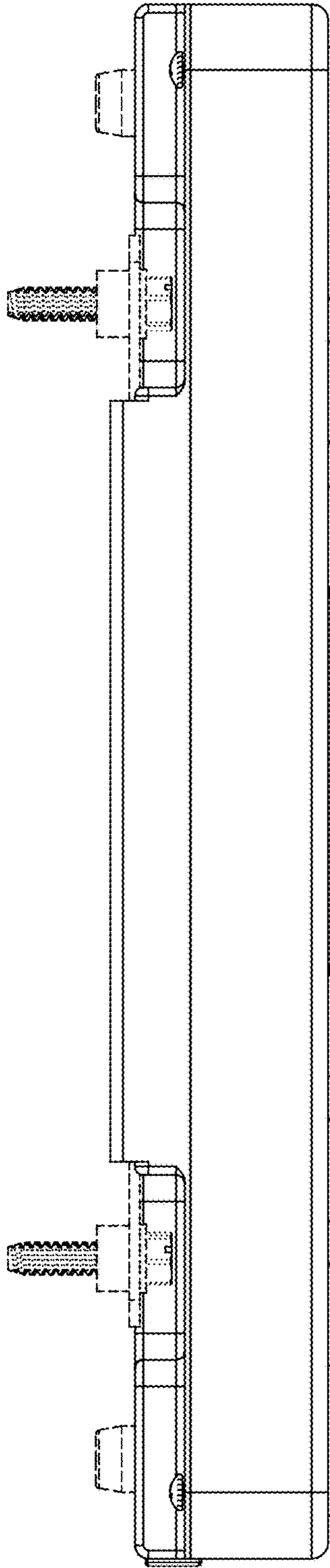

Fig. 15

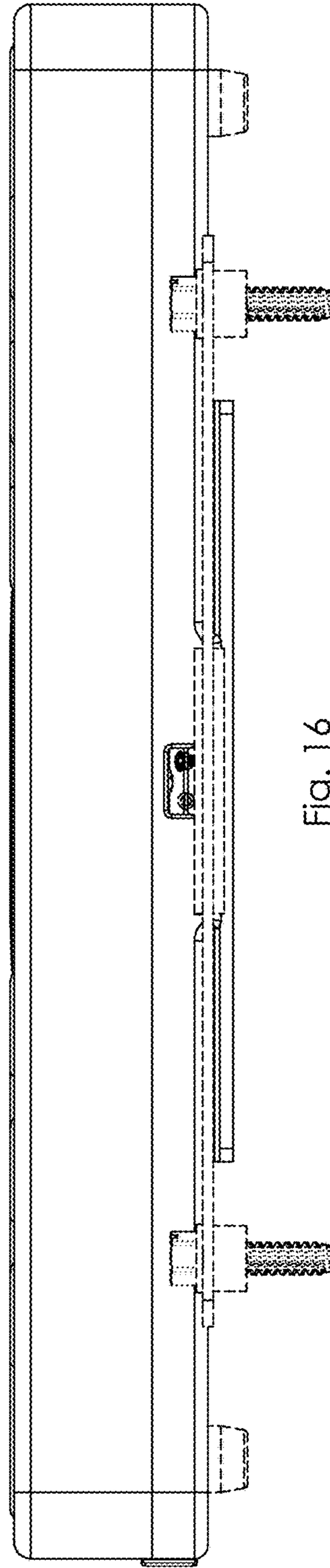

Fig. 16