



US00D843802S

(12) **United States Design Patent**
Torres Delgado et al.

(10) **Patent No.:** **US D843,802 S**
(45) **Date of Patent:** **** Mar. 26, 2019**

- (54) **BUMPER DRIVE LINK**
- (71) Applicant: **Blount, Inc.**, Portland, OR (US)
- (72) Inventors: **Roberto de Jesus Torres Delgado**,
Portland, OR (US); **James Matthew**
Cunnington, Tualatin, OR (US);
Michael D. Harfst, Milwaukie, OR
(US); **Sam Hutsell**, Portland, OR (US)
- (73) Assignee: **Blount, Inc.**, Portland, OR (US)
- (**) Term: **15 Years**

2,912,020	A *	11/1959	Consoletti	B27B 33/142 83/834
2,963,055	A *	12/1960	Stihl	B27B 33/14 83/830
2,989,096	A *	6/1961	Irgens	B27B 33/14 83/833
3,036,606	A *	5/1962	Richardson	B27B 33/142 83/834
3,180,378	A *	4/1965	Carlton	B27B 33/141 83/834
3,204,672	A *	9/1965	Aitken	B27B 33/148 83/831
3,360,022	A *	12/1967	Stihl	B27B 33/14 83/830
3,366,150	A *	1/1968	Malloff	B27B 33/14 83/833

- (21) Appl. No.: **29/640,490**
- (22) Filed: **Mar. 14, 2018**
- (51) **LOC (11) Cl.** **08-03**
- (52) **U.S. Cl.**
USPC **D8/65; D8/70; D15/139**
- (58) **Field of Classification Search**
USPC **D8/8, 9, 65; D15/138, 139**
CPC ... **B27B 33/142; B27B 33/141; B27B 33/144;**
B27B 33/145; B27B 33/148; B27B 33/14;
B27B 33/00; B23D 65/00; B23D 65/02;
Y10T 83/9319; Y10T 83/917
See application file for complete search history.

(Continued)

Primary Examiner — Sandra S Snapp
Assistant Examiner — Ieisha N Price
(74) *Attorney, Agent, or Firm* — Schwabe Williamson &
Wyatt, P.C.

(57) **CLAIM**

We claim the ornamental design for a bumper drive link, as shown and described.

DESCRIPTION

FIG. 1 is a perspective view of a bumper drive link showing our new design;
FIG. 2 is a front view thereof;
FIG. 3 is a back view thereof;
FIG. 4 is a left side view thereof;
FIG. 5 is a right side view thereof;
FIG. 6 is a top view thereof; and,
FIG. 7 is a bottom view thereof.
The dash-dot-dot-dash broken line immediately adjacent to the shaded area represents an unclaimed boundary of the claimed design. The remainder of the broken lines are provided for environmental purposes only and form no part of the claimed design.

- (56) **References Cited**
U.S. PATENT DOCUMENTS
- 2,508,784 A * 5/1950 Cox B27B 33/142
83/834
- 2,713,276 A * 7/1955 Siverson B27B 33/142
72/340
- 2,730,143 A * 1/1956 Ryde B27B 33/142
83/834
- 2,747,624 A * 5/1956 Cox B27B 33/148
474/223
- 2,798,381 A * 7/1957 Siverson B27B 33/14
474/206

1 Claim, 2 Drawing Sheets

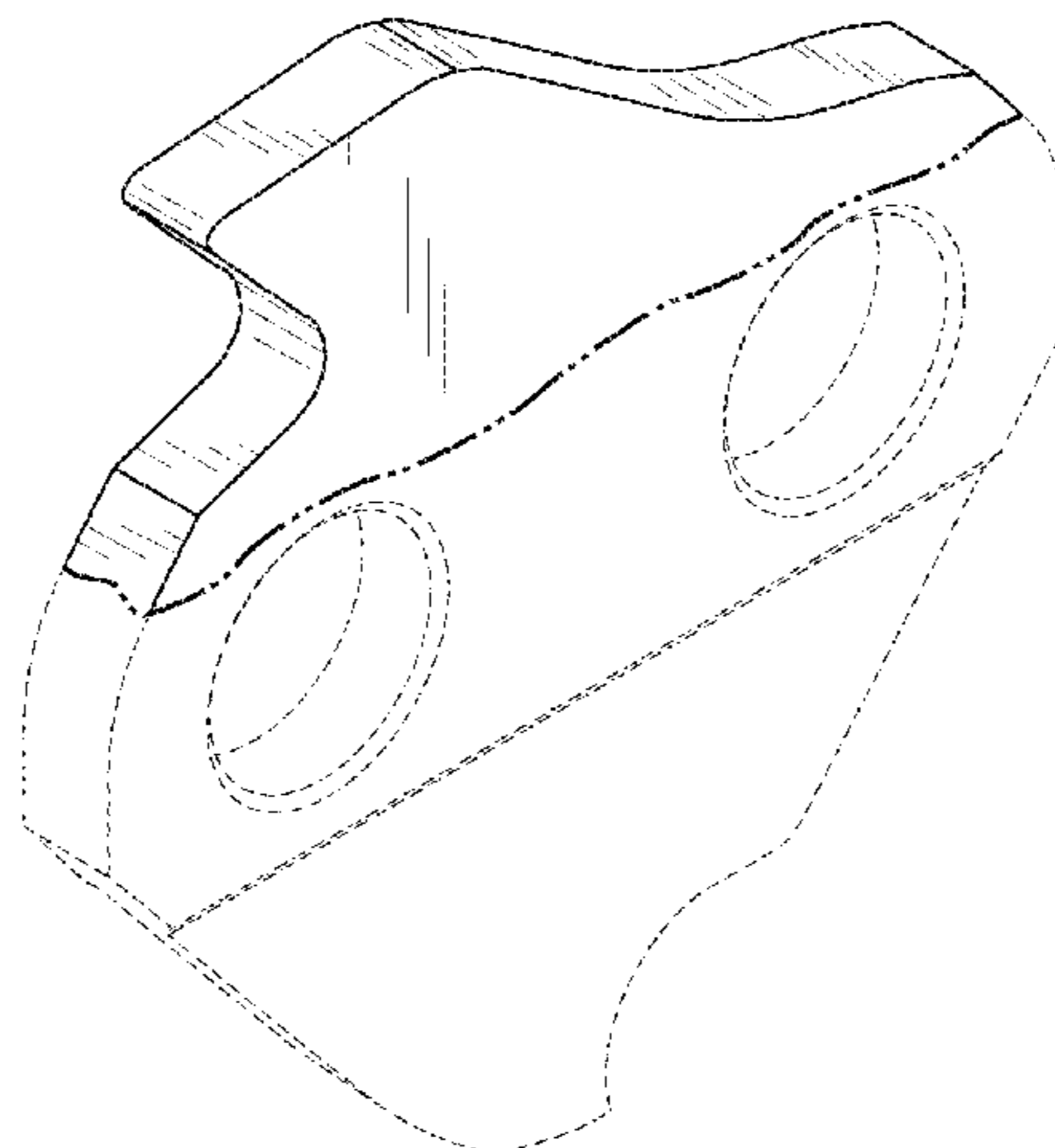

(56)

References Cited

U.S. PATENT DOCUMENTS

3,545,508 A *	12/1970	Tupper	B27B 33/14	83/833	5,651,938 A *	7/1997	Thomson	B27B 33/14	420/119
3,601,167 A *	8/1971	Dolata	B27B 33/14	83/830	6,138,658 A *	10/2000	Bell	B28D 1/124	125/21
3,625,266 A *	12/1971	Kennemore	B27B 33/142	83/830	D535,169 S *	1/2007	Sultan	D8/70	
4,269,100 A *	5/1981	Deelman	B27B 33/141	83/834	7,637,192 B2 *	12/2009	Goettel	B27B 33/141	
4,434,556 A *	3/1984	Nitschmann	B27B 33/147	184/15.1	D715,341 S *	10/2014	Schell	D15/139	
4,796,360 A *	1/1989	Fischer	B27B 17/08	30/384	D730,138 S *	5/2015	Schulz	D8/65	
4,911,050 A *	3/1990	Nitschmann	B27B 33/141	83/834	9,732,795 B2 *	8/2017	Gerstenberger	B27B 33/147	
5,098,348 A *	3/1992	O'Neel	F16H 7/06	30/381	2004/0182216 A1 *	9/2004	Morrison	B27B 33/14	83/661
						2006/0243097 A1 *	11/2006	Raczykowski	B27B 33/144	76/112
						2007/0169605 A1 *	7/2007	Szymanski	B23D 61/06	83/834
						2014/0090532 A1 *	4/2014	Goettel	B23D 63/164	83/174
						2017/0282398 A1 *	10/2017	Viscardi	B27B 33/14	

* cited by examiner

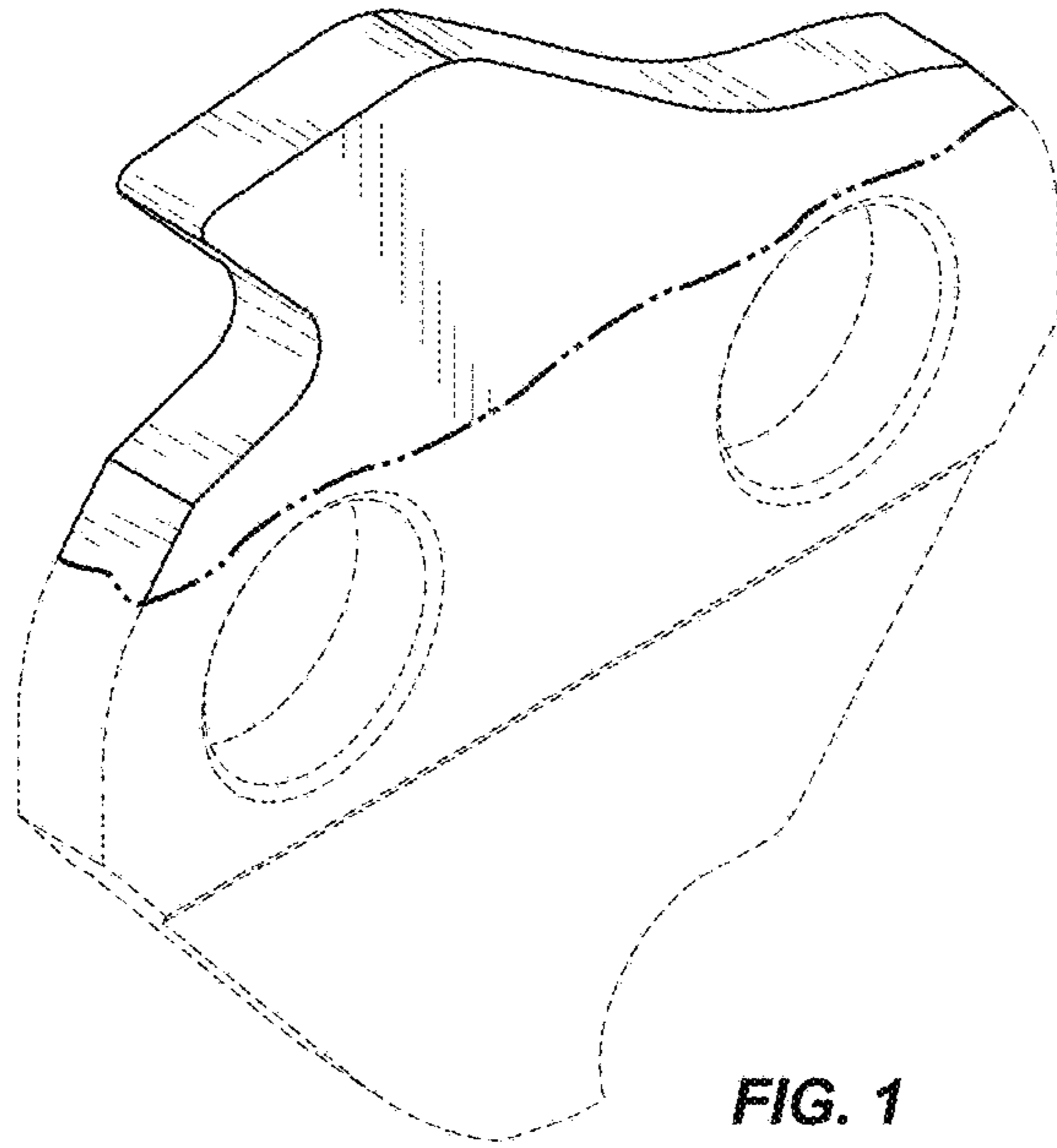

FIG. 1

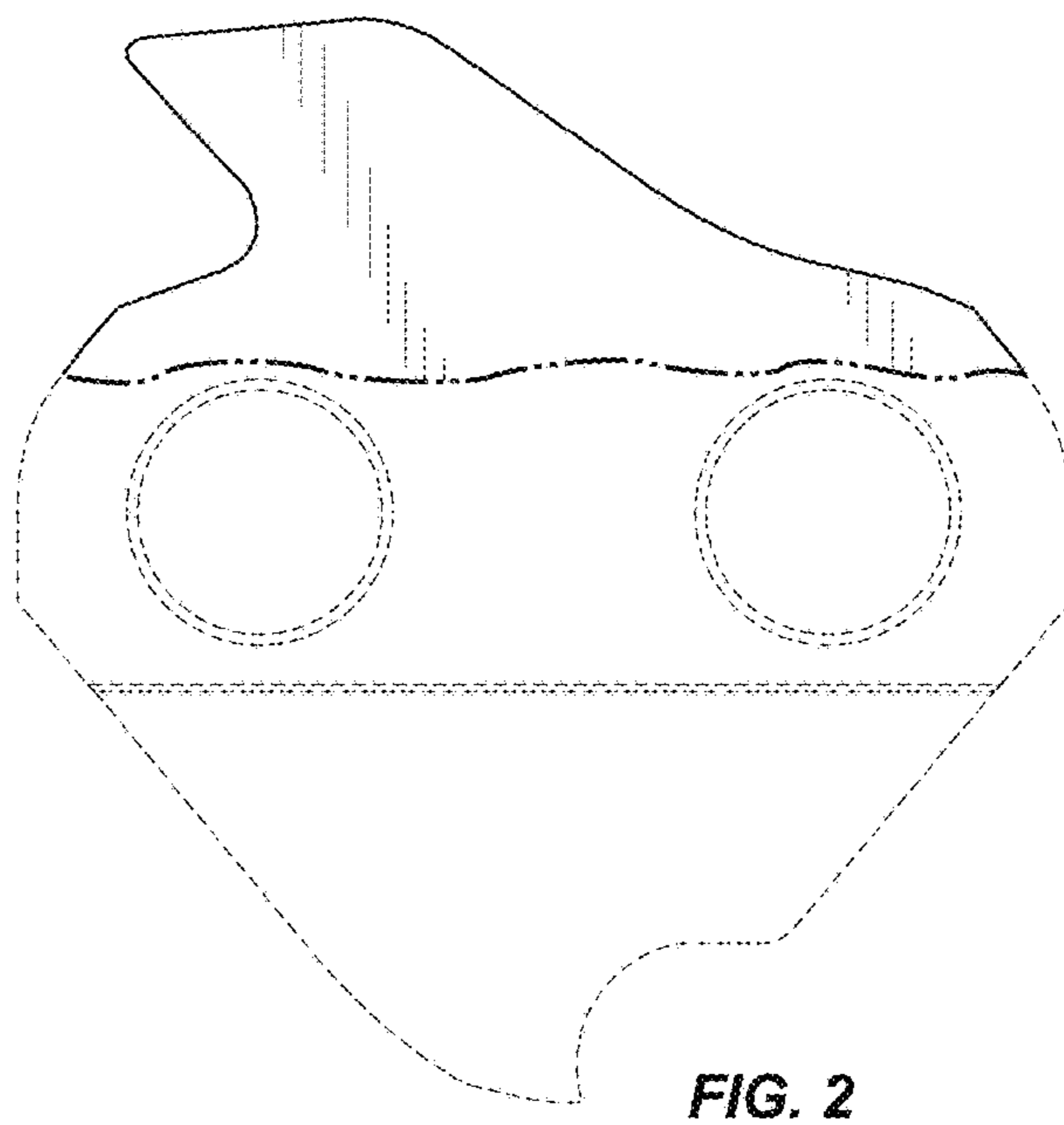

FIG. 2

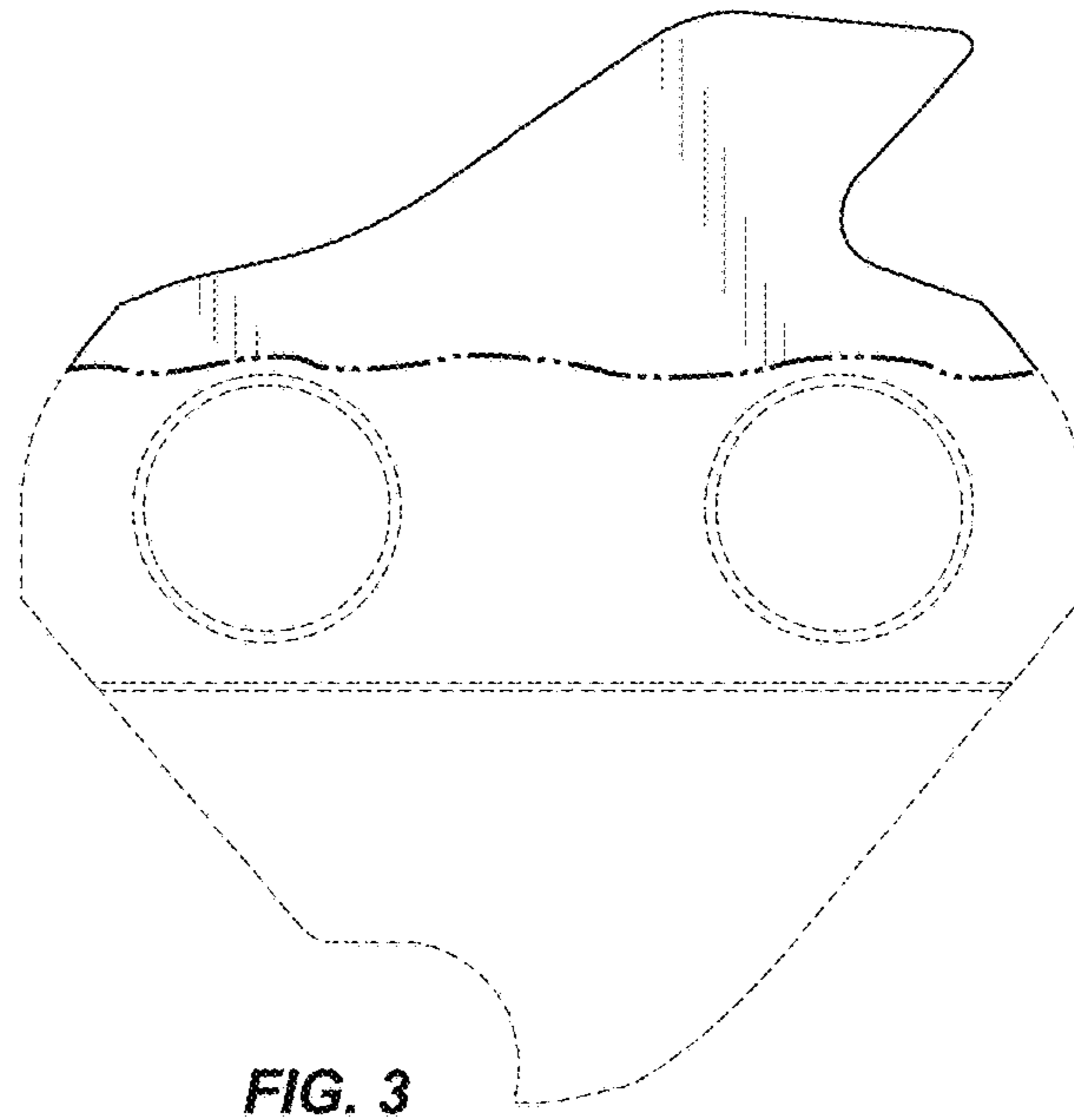

FIG. 3

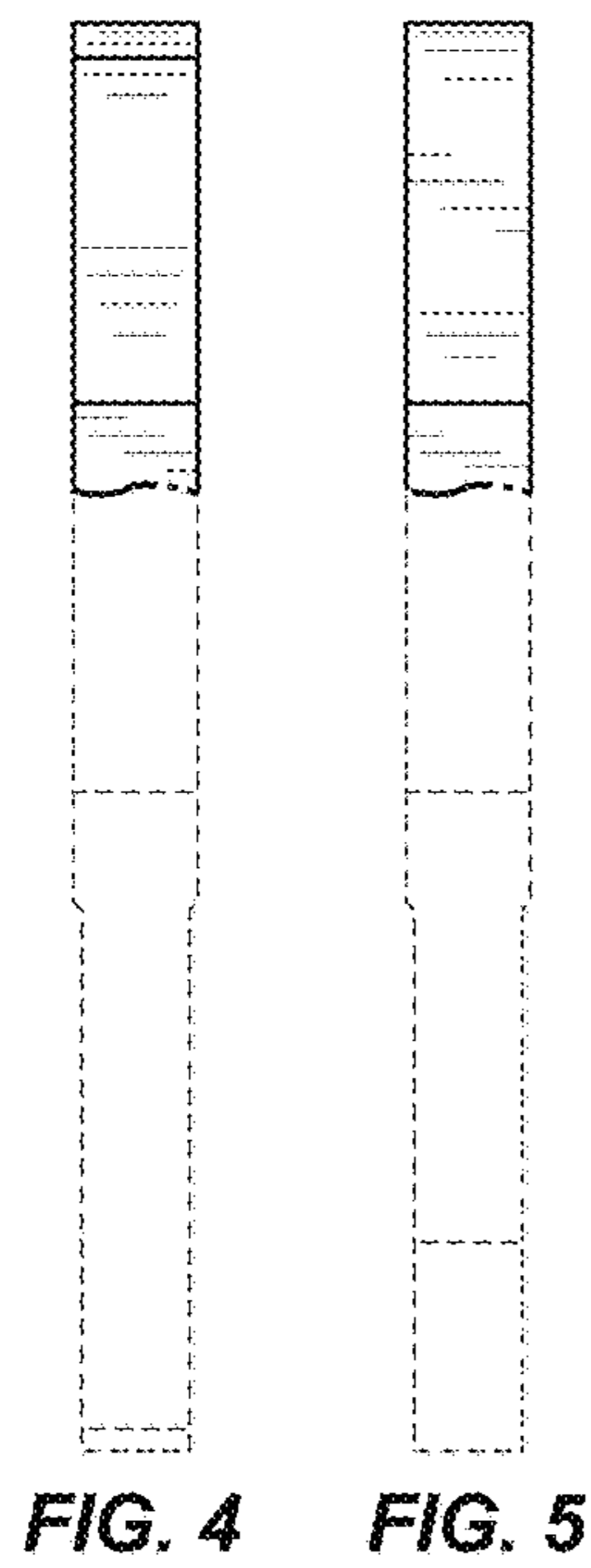

FIG. 4

FIG. 5



FIG. 6

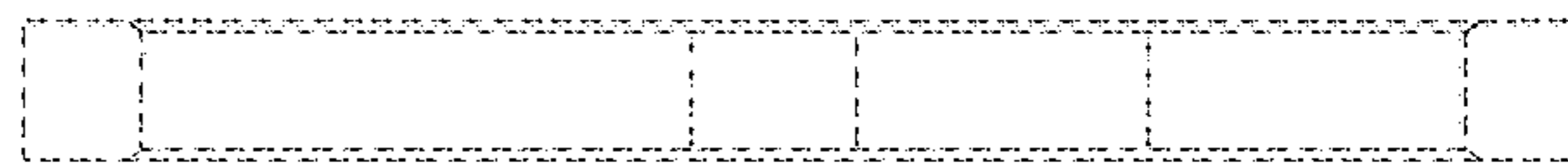

FIG. 7