



US00D842675S

(12) **United States Design Patent**  
**Raymond et al.**

(10) **Patent No.:** **US D842,675 S**  
(45) **Date of Patent:** **\*\* Mar. 12, 2019**

- (54) **COMBINED VEHICLE HANDLE AND GRIP**
- (71) Applicant: **Welcome Distributing, LLC**, Everett, WA (US)
- (72) Inventors: **Clark Raymond**, Snohomish, WA (US); **Landon White**, Everett, WA (US)
- (73) Assignee: **Welcome Distributing, LLC**, Everett, WA (US)
- (\*\*) Term: **15 Years**
- (21) Appl. No.: **29/635,827**
- (22) Filed: **Feb. 2, 2018**
- (51) **LOC (11) Cl.** ..... **08-06**
- (52) **U.S. Cl.**  
USPC ..... **D8/303; D8/308**
- (58) **Field of Classification Search**  
USPC ..... D8/107, 300-303, 308; D7/394; D12/114, 179, 400, 415, 416  
CPC ..... Y10T 16/469; Y10T 16/476; Y10T 16/44; Y10T 292/1089; Y10T 16/466; Y10T 16/4713; Y10T 292/57; Y10T 74/20828; Y10T 16/4644; Y10T 16/513; Y10T 29/49826; Y10T 74/20822; Y10T 16/458; Y10T 16/4652; Y10T 74/20732; Y10T 70/5761; Y10T 292/0956; Y10T 16/4559; Y10T 292/1049; Y10T 16/459; Y10T 74/20864; Y10T 70/5889; Y10T 292/1083; Y10T 292/1041; Y10T 70/577; Y10T 292/0891; Y10T 292/0849; Y10T 407/1825; Y10T 292/1072; Y10S 292/23; Y10S 16/12; Y10S 16/24; Y10S 292/27; Y10S 292/65; Y10S 16/19; Y10S 292/53; Y10S 16/40; Y10S 56/18; B25G 1/102; B25G 1/10; B25G 1/00

See application file for complete search history.

(56) **References Cited**

U.S. PATENT DOCUMENTS

D81,158 S *	5/1930	Schnell	.....	D8/308
2,344,545 A *	3/1944	Harder	.....	B62J 23/00 2/17
D256,405 S *	8/1980	Wheeler	.....	D3/315
D260,961 S *	9/1981	Leehaug	.....	81/177.2
D265,624 S *	8/1982	Goldfracht	.....	D8/107
4,626,016 A *	12/1986	Bergsten	.....	B60N 3/02 105/354
D339,892 S *	9/1993	Wu	.....	D34/15
5,494,283 A *	2/1996	Harris	.....	F41B 15/02 119/801
D377,596 S *	1/1997	Simon	.....	D8/315

(Continued)

*Primary Examiner* — Lauren R Calve

(74) *Attorney, Agent, or Firm* — Lynette Wylie; Apex Juris, pllc.

(57) **CLAIM**

The ornamental design for a combined vehicle handle and grip, as shown and described.

**DESCRIPTION**

- FIG. 1 is a perspective side view of a combined vehicle handle and grip.
- FIG. 2 is a front view of the combined vehicle handle and grip.
- FIG. 3 is a back view of the combined vehicle handle and grip.
- FIG. 4 is a left side view of the combined vehicle handle and grip.
- FIG. 5 is a right side view of the combined vehicle handle and grip.
- FIG. 6 is a top view of the combined vehicle handle and grip.
- FIG. 7 is a bottom view of the combined vehicle handle and grip; and,
- FIG. 8 is an exploded side perspective view of the vehicle handle and grip.

**1 Claim, 8 Drawing Sheets**

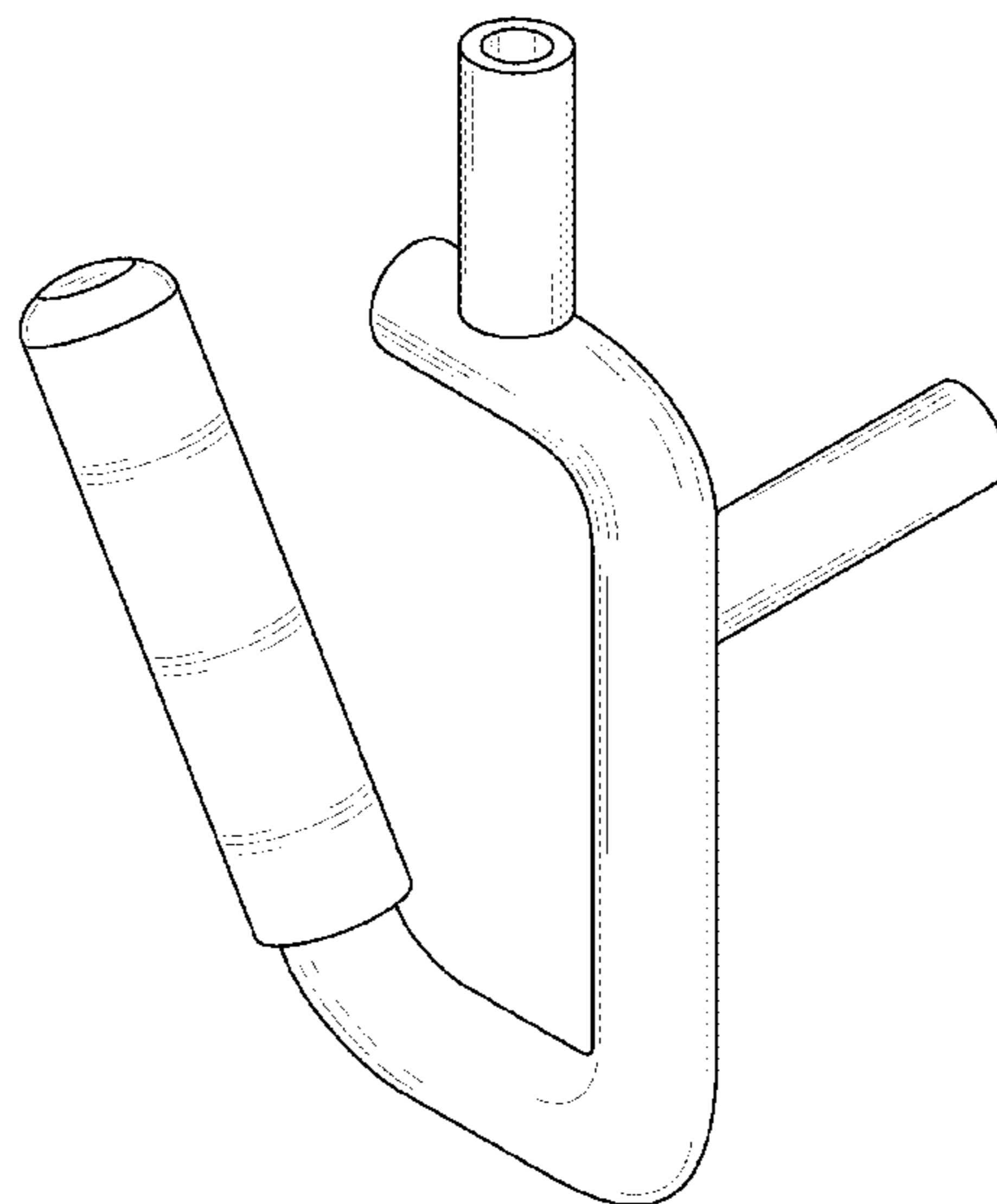

(56)

**References Cited**

U.S. PATENT DOCUMENTS

D395,078 S \* 6/1998 Johnson ..... D23/311  
D441,162 S \* 4/2001 Grove ..... D12/133  
6,289,557 B1 \* 9/2001 Manson ..... E05B 1/0053  
16/412  
D527,776 S \* 9/2006 Willardson ..... D21/694  
D533,046 S \* 12/2006 Donald ..... D8/301  
D547,159 S \* 7/2007 Porth ..... D8/303  
D637,885 S \* 5/2011 Buck ..... D8/308  
D697,677 S \* 1/2014 Ritchey ..... D30/151  
D766,809 S \* 9/2016 Deng ..... D12/400  
2016/0256733 A1 \* 9/2016 Lagree ..... A63B 21/0407

\* cited by examiner

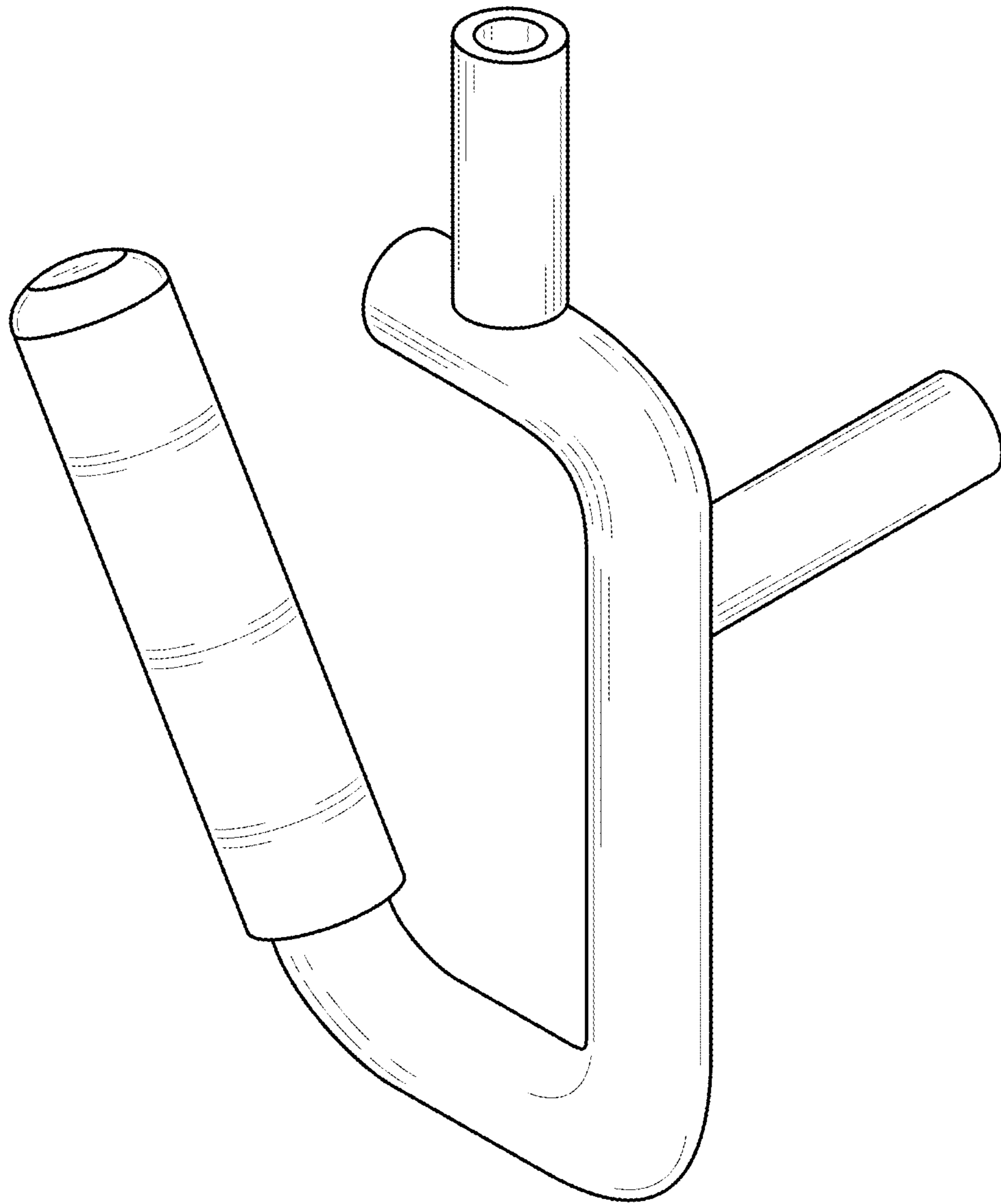

FIG. 1

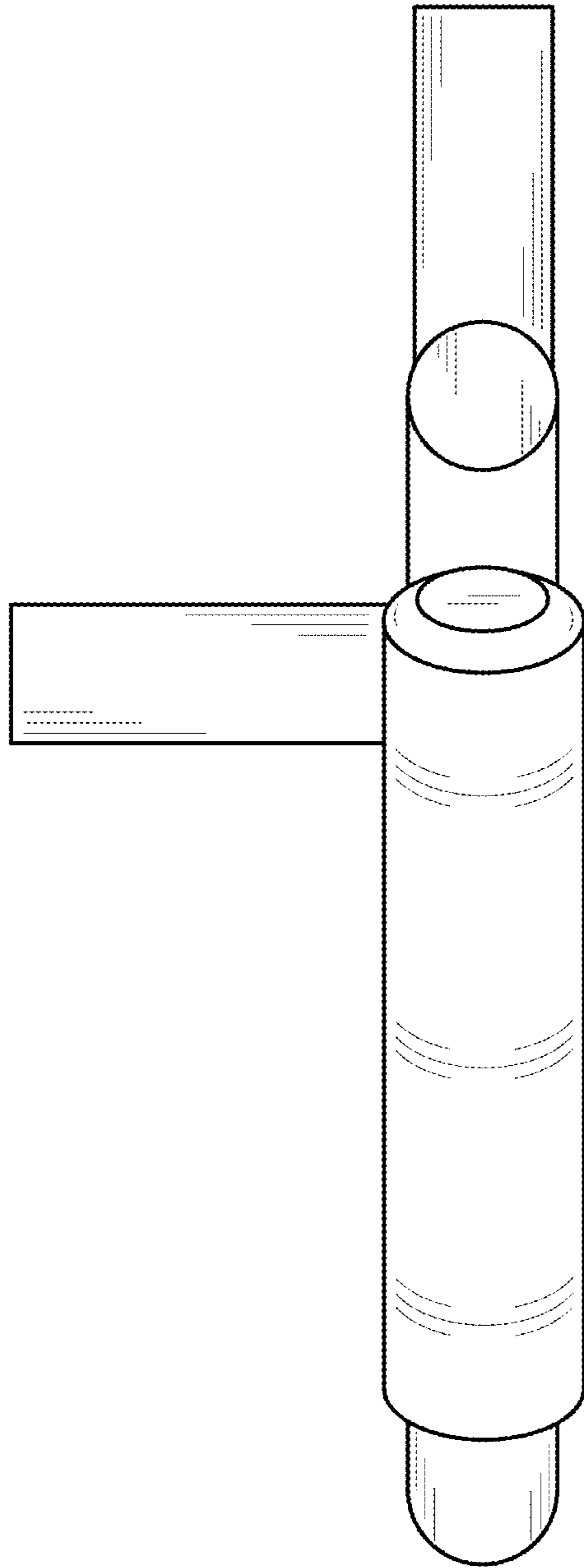

FIG. 2

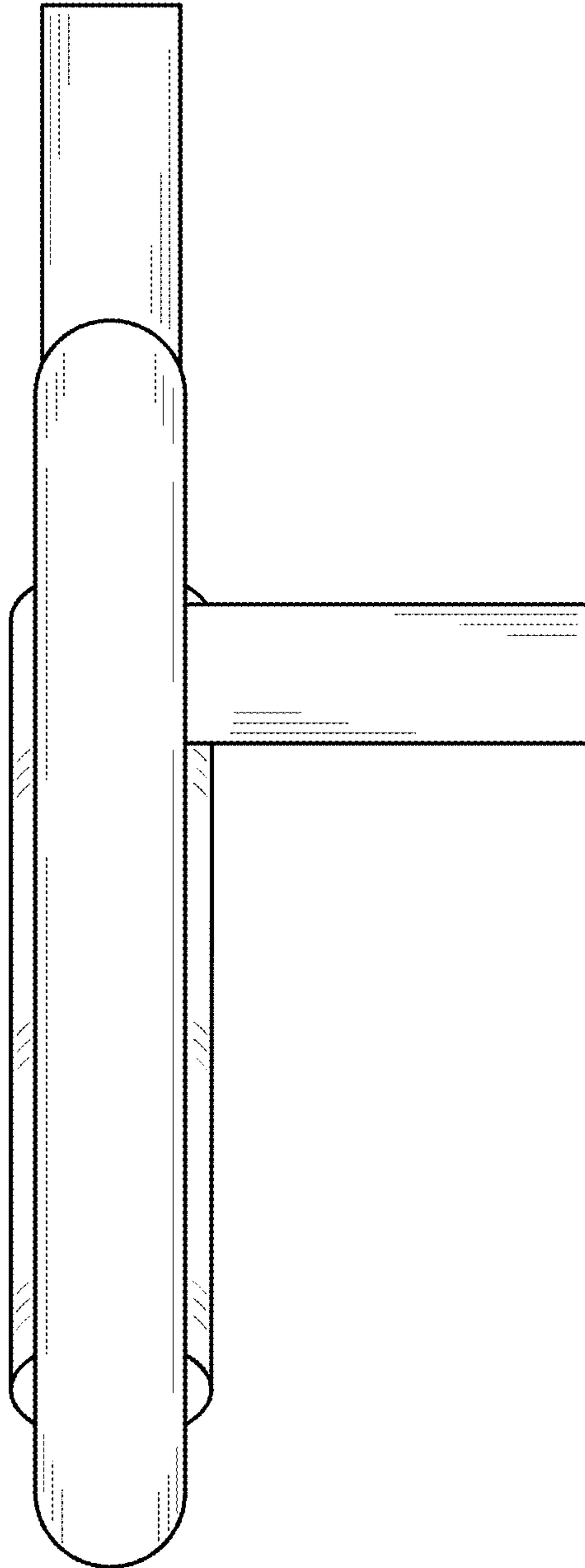

FIG. 3

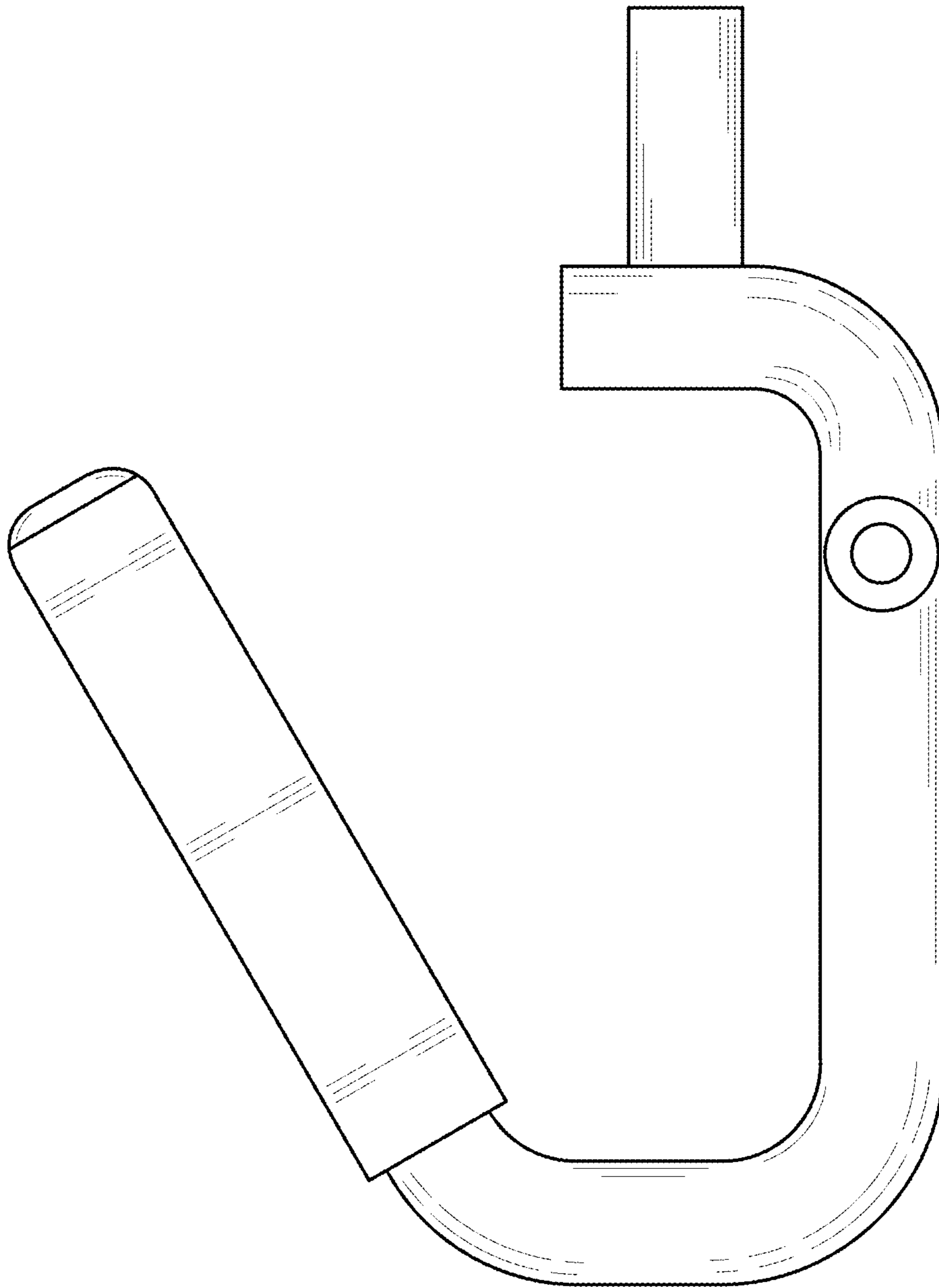

FIG. 4

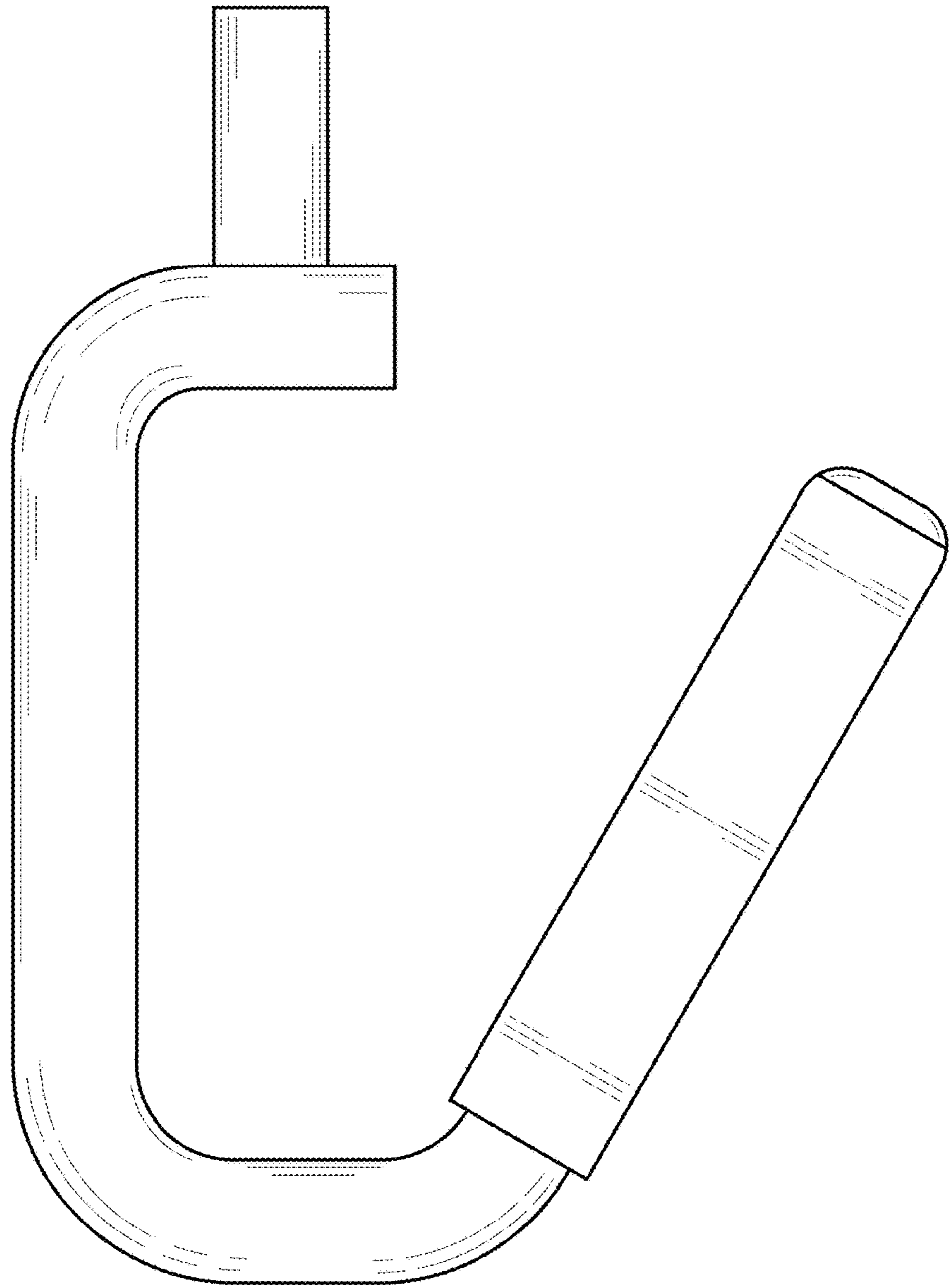

FIG. 5

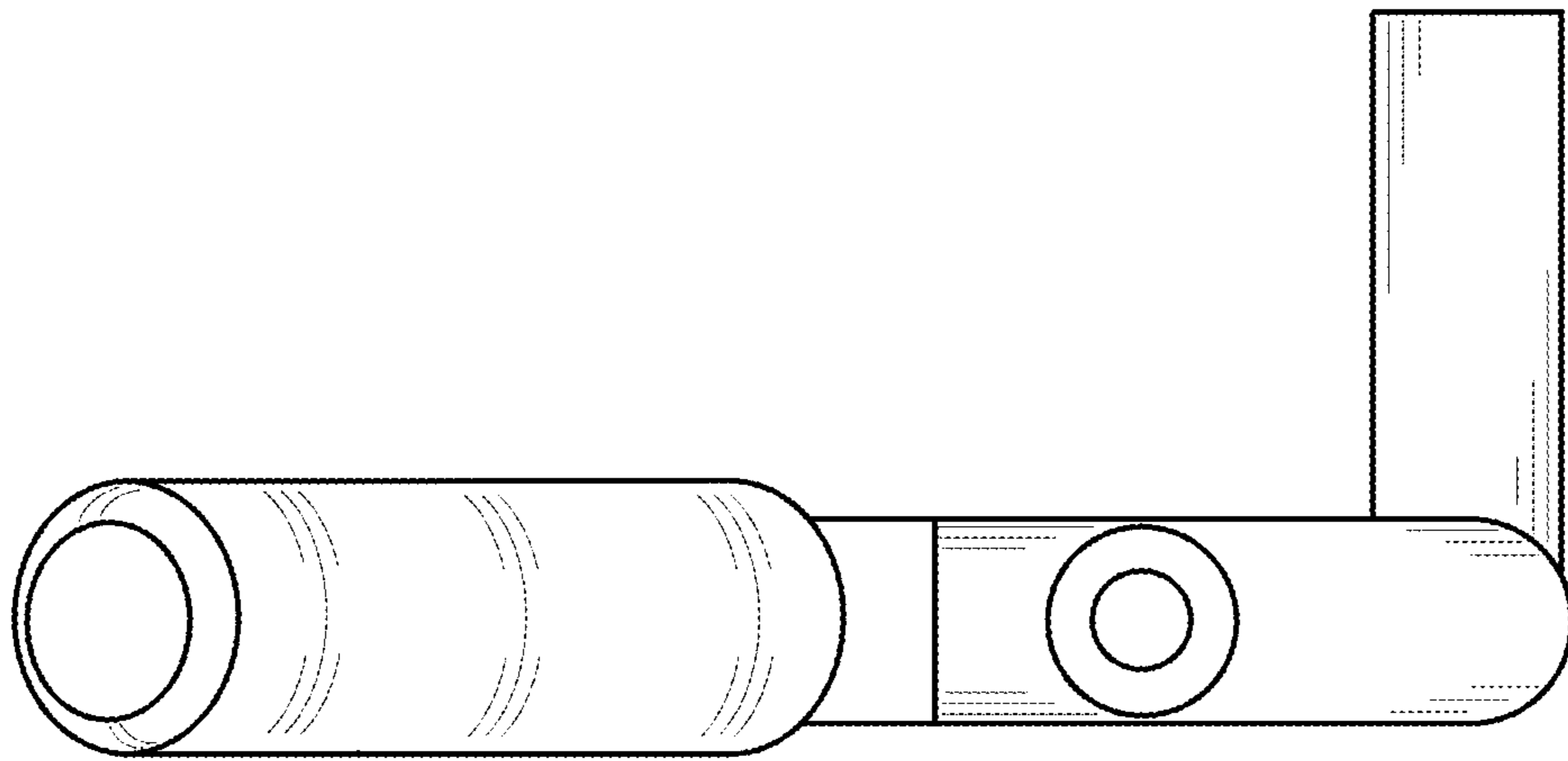

FIG. 6



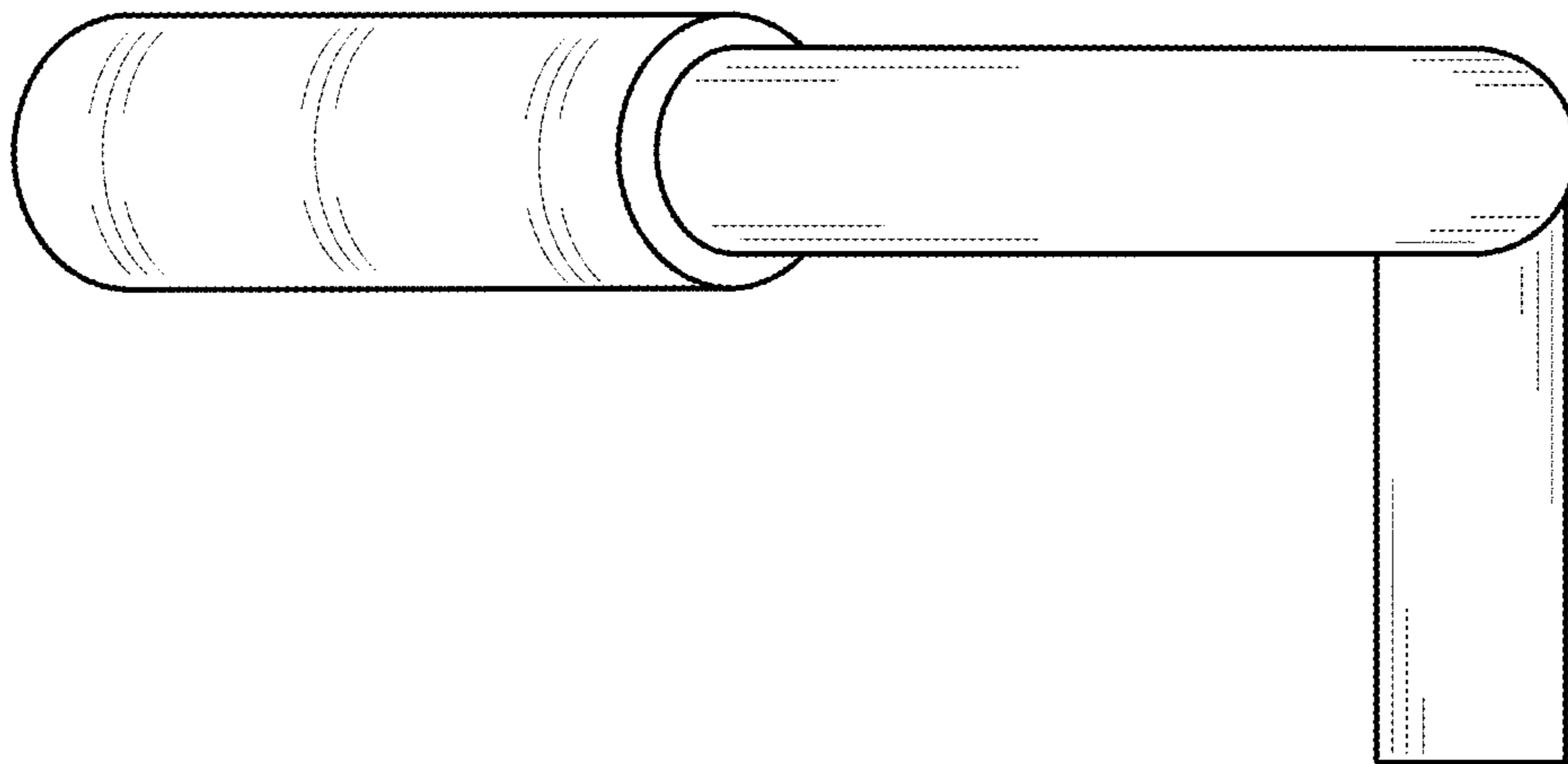

FIG. 7

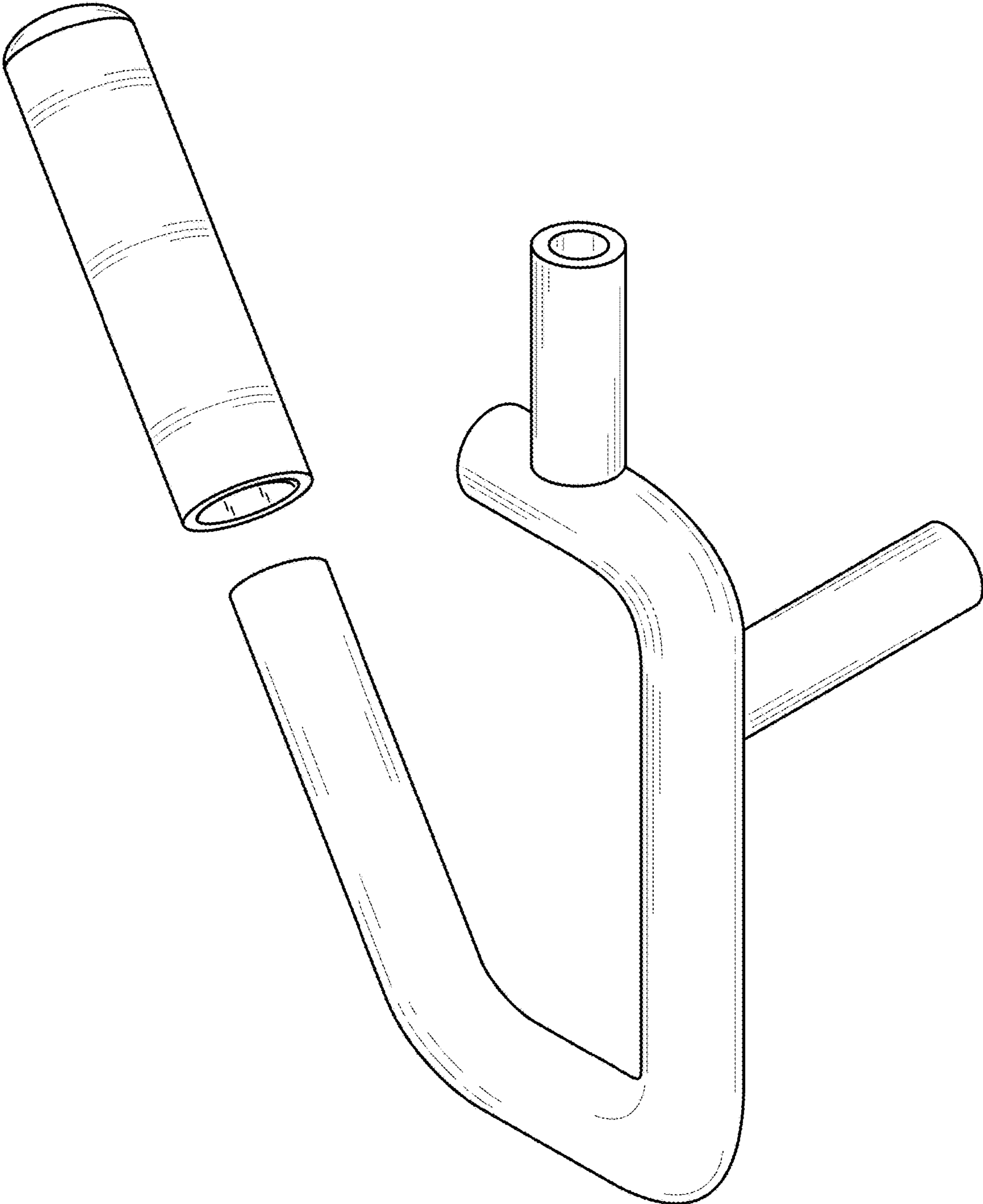

FIG. 8