



US00D842536S

(12) **United States Design Patent**
Bowen et al.

(10) **Patent No.:** **US D842,536 S**
(45) **Date of Patent:** **** Mar. 5, 2019**

(54) **VAPORIZER CARTRIDGE**
(71) Applicant: **JUUL Labs, Inc.**, San Francisco, CA (US)
(72) Inventors: **Adam Bowen**, San Francisco, CA (US); **James Monsees**, San Francisco, CA (US); **Steven Christensen**, San Francisco, CA (US); **Joshua Morenstein**, San Francisco, CA (US); **Christopher Nicholas HibmaCronan**, Oakland, CA (US)

(73) Assignee: **JUUL Labs, Inc.**, San Francisco, CA (US)

(**) Term: **15 Years**

(21) Appl. No.: **35/001,170**

(22) Filed: **Jul. 28, 2016**

(80) **Hague Agreement Data**

Int. Filing Date: **Mar. 11, 2016**

Int. Reg. No.: **DM/092571**

Int. Reg. Date: **Jul. 28, 2016**

Int. Reg. Pub. Date: **Feb. 3, 2017**

(51) **LOC (11) Cl.** **27-02**

(52) **U.S. Cl.**
USPC **D27/167**

(58) **Field of Classification Search**
USPC D27/102, 105, 106, 110-112, 162, 167
CPC A24F 19/0064; A24F 15/18; A24F 13/20;
A24F 13/18; A24F 23/00; A24F 19/0085;
A24F 19/14; A24F 13/14; A24F 19/00;
B65D 5/18; B65D 5/0209
See application file for complete search history.

(56) **References Cited**

U.S. PATENT DOCUMENTS

374,584 A 12/1887 Cook
576,653 A 2/1897 Bowlby

595,070 A 12/1897 Oldenbusch
720,007 A 2/1903 Dexter
799,844 A 9/1905 Fuller
968,160 A 8/1910 Johnson
969,076 A 8/1910 Pender
1,067,531 A 7/1913 MacGregor
1,163,183 A 12/1915 Stoll
1,299,162 A 4/1919 Fisher
1,485,260 A 2/1924 Fritz
1,505,748 A 8/1924 Louis
1,552,877 A 9/1925 Phillipps et al.
1,632,335 A 6/1927 Hierung
1,706,244 A 3/1929 Louis
1,845,340 A 2/1932 Ritz
1,972,118 A 9/1934 McDill
1,998,683 A 4/1935 Montgomery
2,031,363 A 2/1936 Elof
2,039,559 A 5/1936 Segal
2,104,266 A 1/1938 McCormick
2,159,698 A 5/1939 Harris et al.
2,177,636 A 10/1939 Coffelt et al.
2,195,260 A 3/1940 Rasener
2,231,909 A 2/1941 Hempal
2,327,120 A 8/1943 McCoon
D142,178 S 8/1945 Becwar
2,460,427 A 2/1949 Musselman et al.
2,483,304 A 9/1949 Rudolf
2,502,561 A 4/1950 Ludwig
2,765,949 A 10/1956 Swan
2,830,597 A 4/1958 Kummli
2,860,638 A 11/1958 Bartolomeo
2,897,958 A 8/1959 Tarleton et al.
2,935,987 A 5/1960 Ackerbauer
2,956,569 A 10/1960 Adams
D194,088 S 11/1962 Mann
3,085,145 A 4/1963 Wray
3,146,937 A 9/1964 Joseph
3,258,015 A 6/1966 Ellis et al.
3,271,719 A 9/1966 Ovshinsky
3,292,634 A 12/1966 Beucler
D207,887 S 6/1967 Parsisson
3,373,915 A 3/1968 Anderson et al.
3,420,360 A 1/1969 Young
3,443,827 A 5/1969 Acker et al.
3,456,645 A 7/1969 Brock
3,479,561 A 11/1969 Janning
3,567,014 A 3/1971 Feigelman
3,675,661 A 7/1972 Weaver
3,707,017 A 12/1972 Paquette
3,779,770 A 12/1973 Alston et al.
3,792,704 A 2/1974 Parker
3,815,597 A 6/1974 Goettelman
3,861,523 A 1/1975 Fountain et al.

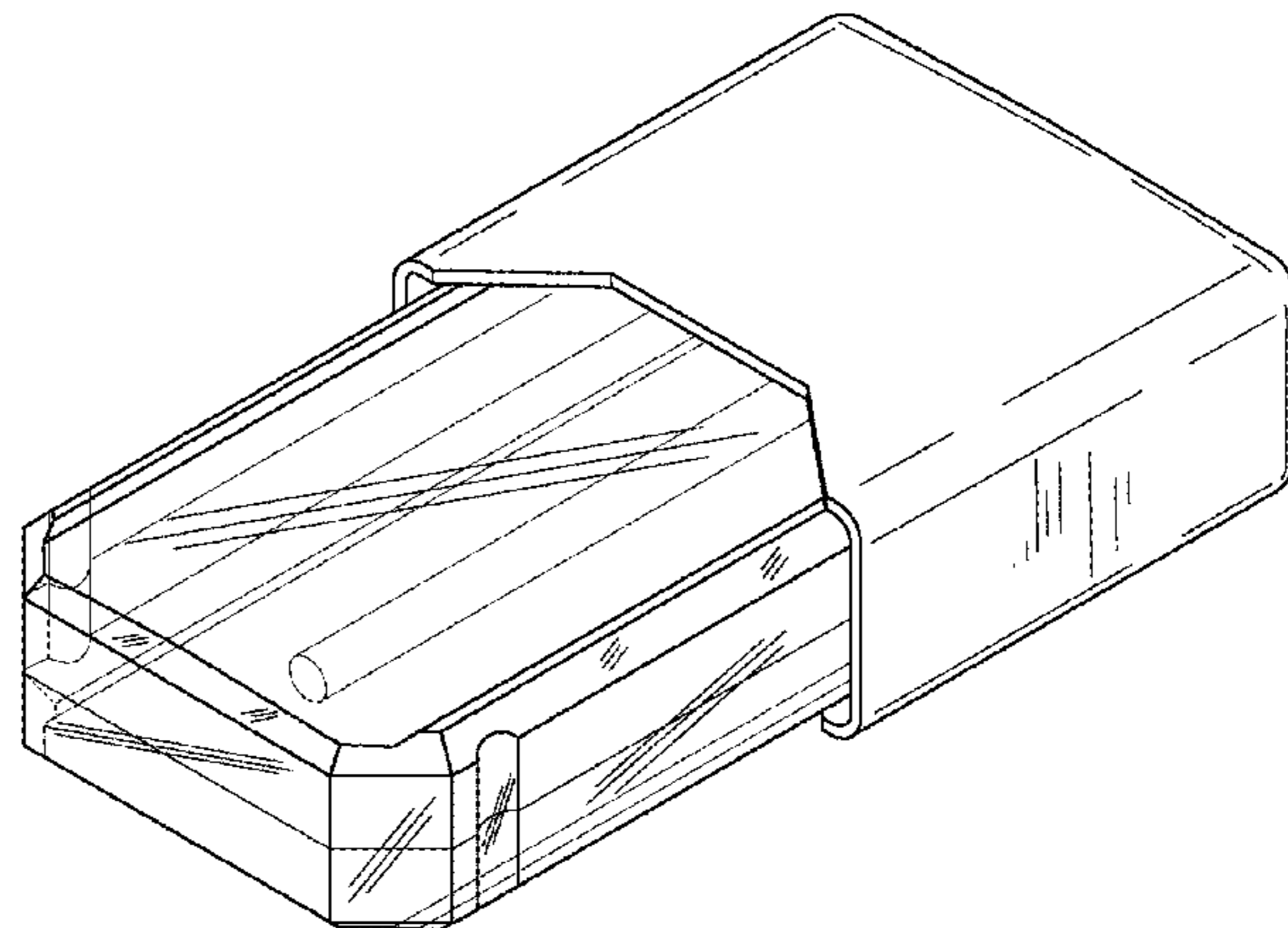
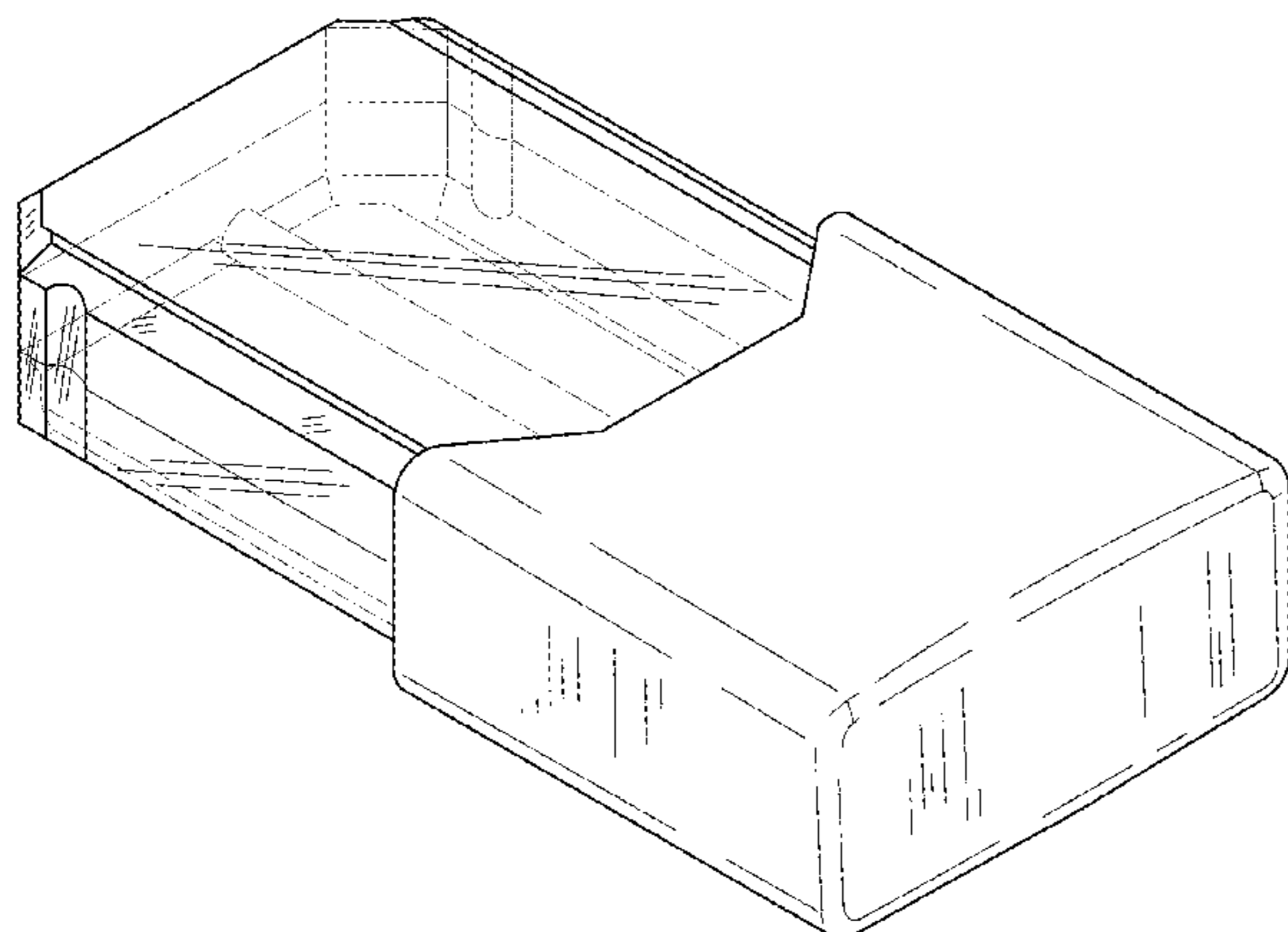

US D842,536 S

3,941,300 A	3/1976	Troth	5,175,791 A	12/1992	Muderlak et al.
4,020,853 A	5/1977	Nuttall	5,183,062 A	2/1993	Clearman et al.
4,049,005 A	9/1977	Hernandez et al.	D336,346 S	6/1993	Miller et al.
4,066,088 A	1/1978	Ensor	5,224,498 A	7/1993	Deevi et al.
D250,485 S	12/1978	Cuthbertson	5,228,460 A	7/1993	Sprinkel et al.
D255,548 S	6/1980	Grodin	5,240,012 A	8/1993	Ehrman et al.
4,207,976 A	6/1980	Herman	5,249,586 A	10/1993	Morgan et al.
4,215,708 A	8/1980	Bron	5,261,424 A	11/1993	Sprinkel, Jr.
4,219,032 A	8/1980	Tabatznik et al.	5,269,237 A	12/1993	Baker et al.
D260,690 S	9/1981	Stutzer	5,269,327 A	12/1993	Counts et al.
4,303,083 A	12/1981	Burruss, Jr.	H1271 H	1/1994	Shouse
4,312,367 A	1/1982	Seeman	5,296,685 A	3/1994	Burstein et al.
4,347,855 A	9/1982	Lanzillotti et al.	5,303,720 A	4/1994	Banerjee et al.
4,391,285 A	7/1983	Burnett et al.	5,322,075 A	6/1994	Deevi et al.
D271,255 S	11/1983	Rousseau	5,324,498 A	6/1994	Streusand et al.
4,492,480 A	1/1985	Wadso et al.	5,345,951 A	9/1994	Serrano et al.
4,506,683 A	3/1985	Cantrell et al.	5,369,723 A	11/1994	Counts et al.
4,519,319 A	5/1985	Howlett	5,372,148 A	12/1994	McCafferty et al.
4,520,938 A	6/1985	Finke	5,388,574 A	2/1995	Ingebretsen
D280,494 S	9/1985	Abel	5,449,078 A	9/1995	Akers
4,595,024 A	6/1986	Greene et al.	5,456,269 A	10/1995	Kollasch
4,625,737 A	12/1986	Keritsis et al.	5,472,001 A	12/1995	Nicholson
4,648,393 A	3/1987	Landis et al.	D367,605 S	3/1996	Moore
4,708,151 A	11/1987	Shelar	5,497,791 A	3/1996	Bowen et al.
4,735,217 A	4/1988	Gerth et al.	D368,552 S	4/1996	Adams
4,771,796 A	9/1988	Myer	5,529,078 A	6/1996	Rehder et al.
4,793,365 A	12/1988	Sensabaugh, Jr. et al.	D371,633 S	7/1996	Chenard
4,794,323 A	12/1988	Zhou et al.	5,545,904 A	8/1996	Orbach
4,798,310 A	1/1989	Kasai et al.	5,564,442 A	10/1996	MacDonald et al.
4,813,536 A	3/1989	Willis	5,579,934 A	12/1996	Buono
4,819,665 A	4/1989	Roberts et al.	5,591,368 A	1/1997	Fleischhauer et al.
4,830,028 A	5/1989	Lawson et al.	5,605,226 A	2/1997	Hernlein
D301,837 S	6/1989	Peterson et al.	D379,810 S *	6/1997	Giordano, Jr. D14/138 R
4,836,224 A	6/1989	Lawson et al.	5,641,064 A	6/1997	Goserud
4,846,199 A	7/1989	Rose	D380,293 S	7/1997	Cudmore
4,848,374 A	7/1989	Chard et al.	5,649,552 A	7/1997	Cho et al.
4,848,563 A	7/1989	Robbins	D382,146 S	8/1997	Sandy
D302,659 S	8/1989	Peterson et al.	5,666,977 A	9/1997	Higgins et al.
D303,722 S	9/1989	Marlow et al.	5,666,978 A	9/1997	Counts et al.
4,870,748 A	10/1989	Hensgen et al.	5,708,258 A	1/1998	Counts et al.
D304,771 S	11/1989	Katayama	5,730,118 A	3/1998	Hermanson
4,893,639 A	1/1990	White	5,730,158 A	3/1998	Collins et al.
4,896,683 A	1/1990	Cohen et al.	5,746,587 A	5/1998	Racine et al.
4,907,606 A	3/1990	Lilja et al.	D397,504 S	8/1998	Zelenik
4,924,883 A	5/1990	Perfetti et al.	D398,150 S *	9/1998	Vonarburg D28/85
4,938,236 A	7/1990	Banerjee et al.	5,807,509 A	9/1998	Shrier et al.
4,941,483 A	7/1990	Ridings et al.	5,810,164 A	9/1998	Rennecamp
4,944,317 A	7/1990	Thal	5,819,756 A	10/1998	Mielordt
D310,171 S	8/1990	Cusenza	5,845,649 A	12/1998	Saito et al.
4,945,929 A	8/1990	Egilmex	D405,007 S	2/1999	Naas, Sr.
4,947,874 A	8/1990	Brooks et al.	5,865,185 A	2/1999	Collins et al.
4,947,875 A	8/1990	Brooks et al.	5,865,186 A	2/1999	Volsey, II
D310,349 S	9/1990	Rowen	5,878,752 A	3/1999	Adams et al.
4,955,397 A	9/1990	Johnson et al.	5,881,884 A	3/1999	Podosek
4,974,609 A	12/1990	Southwick et al.	5,894,841 A	4/1999	Voges
4,984,588 A	1/1991	Stewart, Jr.	D411,332 S	6/1999	Zelenik
D315,032 S	2/1991	Hayes	D412,279 S	7/1999	Brice
5,005,759 A	4/1991	Bouche	5,931,828 A	8/1999	Durkee
5,019,122 A	5/1991	Clearman et al.	5,934,289 A	8/1999	Watkins et al.
5,020,548 A	6/1991	Farrier et al.	5,938,018 A	8/1999	Keaveney et al.
5,027,836 A	7/1991	Shannon et al.	5,944,025 A	8/1999	Cook et al.
5,031,646 A	7/1991	Lippiello et al.	5,954,979 A	9/1999	Counts et al.
5,040,551 A	8/1991	Schlatter et al.	D414,893 S	10/1999	Moore
5,042,509 A	8/1991	Banerjee et al.	5,967,310 A	10/1999	Hill
5,050,621 A	9/1991	Creighton et al.	5,975,415 A	11/1999	Zehnal
5,060,671 A	10/1991	Counts et al.	5,979,460 A	11/1999	Matsumura
5,065,776 A	11/1991	Lawson et al.	5,979,548 A	11/1999	Rhodes et al.
5,076,297 A	12/1991	Farrier et al.	5,994,025 A	11/1999	Iwasa et al.
5,101,838 A	4/1992	Schwartz et al.	5,996,589 A	12/1999	St. Charles
5,105,831 A	4/1992	Banerjee et al.	6,024,097 A	2/2000	Von Wielligh
5,105,836 A	4/1992	Gentry et al.	6,026,820 A	2/2000	Baggett, Jr. et al.
5,105,838 A	4/1992	White et al.	6,040,560 A	3/2000	Fleischhauer et al.
5,123,530 A	6/1992	Lee	D422,884 S *	4/2000	Lafond D8/354
5,127,511 A	7/1992	Keen, Jr. et al.	6,053,176 A	4/2000	Adams et al.
5,133,368 A	7/1992	Neumann et al.	D424,236 S	5/2000	Reed
5,141,004 A	8/1992	Porenski	D424,739 S	5/2000	Ross
5,144,962 A	9/1992	Counts et al.	6,089,857 A	7/2000	Matsuura et al.
5,148,817 A	9/1992	Houminer et al.	6,095,153 A	8/2000	Kessler et al.
5,152,456 A	10/1992	Ross et al.	6,102,036 A	8/2000	Slutsky et al.

US D842,536 S

6,119,684 A	9/2000	Nohl et al.	6,954,979 B2	10/2005	Logan
6,125,853 A	10/2000	Susa et al.	6,994,096 B2	2/2006	Rostami et al.
D433,532 S	11/2000	Higgins et al.	7,000,775 B2	2/2006	Gelardi et al.
6,155,268 A	12/2000	Takeuchi	7,015,796 B2	3/2006	Snyder
6,164,287 A	12/2000	White	7,025,066 B2	4/2006	Lawson et al.
D436,686 S	1/2001	Fujisawa	7,049,926 B2	5/2006	Shrier et al.
6,196,232 B1	3/2001	Chkadua	D523,171 S	6/2006	Mitten et al.
6,216,705 B1	4/2001	Ossepian	D525,948 S	8/2006	Blair et al.
D442,328 S	5/2001	Barnes	7,082,825 B2	8/2006	Aoshima et al.
6,234,169 B1	5/2001	Bulbrook et al.	D528,992 S	9/2006	Hobart et al.
6,239,687 B1	5/2001	Shrier et al.	D529,044 S	9/2006	Andre et al.
6,265,789 B1	7/2001	Honda et al.	7,109,876 B2	9/2006	Smith et al.
D446,499 S	8/2001	Andre et al.	D530,340 S	10/2006	Andre et al.
D447,276 S	8/2001	Gustafson	D531,190 S	10/2006	Lee et al.
6,269,966 B1	8/2001	Pallo et al.	7,117,707 B2	10/2006	Adams et al.
6,310,752 B1	10/2001	Shrier et al.	D532,927 S	11/2006	Sann
D450,313 S	11/2001	Koinuma	D534,921 S	1/2007	Andre et al.
D450,662 S	11/2001	Kwok	D535,261 S	1/2007	Daniels
6,324,261 B1	11/2001	Merte	D535,308 S	1/2007	Andre et al.
6,349,728 B1	2/2002	Pham	7,173,222 B2	2/2007	Cox et al.
D454,079 S	3/2002	Fong	7,185,651 B2	3/2007	Alston et al.
6,381,739 B1	4/2002	Breternitz, Jr. et al.	7,185,659 B2	3/2007	Sharpe
6,386,371 B1	5/2002	Parsons	D539,813 S	4/2007	Chen
6,407,371 B1	6/2002	Toya et al.	D540,131 S	4/2007	Swann
6,418,938 B1	7/2002	Fleischhauer et al.	D540,687 S	4/2007	Egawa
6,431,363 B1	8/2002	Hacker	D540,749 S	4/2007	Kaule
6,443,146 B1	9/2002	Voges	7,214,075 B2	5/2007	He et al.
6,446,793 B1	9/2002	Layshock	D544,643 S	6/2007	Lin
D465,660 S	11/2002	Doeing	D545,303 S	6/2007	Chang
6,510,982 B2	1/2003	White et al.	7,234,593 B2	6/2007	Fath et al.
D471,104 S	3/2003	Hunt	D545,904 S	7/2007	Chen et al.
6,532,965 B1	3/2003	Abhulimen et al.	D546,782 S	7/2007	Poulet et al.
6,536,442 B2	3/2003	St. Charles et al.	D547,002 S	7/2007	Lin
6,542,065 B2	4/2003	Shrier et al.	D551,548 S	9/2007	Didier
6,557,708 B2	5/2003	Polacco	D551,970 S	10/2007	Didier
6,595,362 B2	7/2003	Penney et al.	D553,458 S	10/2007	Hood
6,598,607 B2	7/2003	Adiga et al.	7,275,941 B1	10/2007	Bushby
D477,920 S	8/2003	McCarty et al.	D556,154 S	11/2007	Poulet et al.
D478,569 S	8/2003	Hussaini et al.	7,290,549 B2	11/2007	Banerjee et al.
D478,897 S	8/2003	Tsuge	D557,209 S	12/2007	Ahlgren et al.
6,603,924 B2	8/2003	Brown et al.	D558,060 S *	12/2007	Sir D9/687
6,606,998 B1	8/2003	Gold	D562,151 S	2/2008	Larocca et al.
6,612,404 B2	9/2003	Sweet et al.	D562,761 S	2/2008	Ueda et al.
6,615,840 B1	9/2003	Fournier et al.	D565,496 S	4/2008	Disla
6,622,867 B2	9/2003	Menceles	D568,298 S	5/2008	Lundgren et al.
6,637,430 B1	10/2003	Voges et al.	D569,727 S	5/2008	Moretti
6,655,379 B2	12/2003	Clark et al.	7,367,334 B2	5/2008	Faison, Jr. et al.
6,657,532 B1	12/2003	Shrier et al.	7,374,048 B2	5/2008	Mazurek
D485,639 S	1/2004	Stronski	D571,202 S	6/2008	Vogt
6,672,762 B1	1/2004	Faircloth et al.	D571,556 S *	6/2008	Raile D3/265
6,688,313 B2	2/2004	Wrenn et al.	D573,474 S *	7/2008	Beam D9/423
6,707,274 B1	3/2004	Karr	7,415,982 B1	8/2008	Sheridan
6,708,846 B1	3/2004	Fuchs et al.	D576,619 S	9/2008	Udagawa et al.
6,726,006 B1	4/2004	Funderburk et al.	D577,019 S	9/2008	Udagawa et al.
6,743,030 B2	6/2004	Lin et al.	D577,150 S	9/2008	Bryman et al.
6,747,573 B1	6/2004	Gerlach et al.	D577,591 S	9/2008	Bouroullec et al.
6,752,649 B2	6/2004	Arkin et al.	7,428,905 B2	9/2008	Mua
D494,315 S	8/2004	Cartier	7,434,584 B2	10/2008	Steinberg
6,769,436 B2	8/2004	Horian	D580,756 S	11/2008	Seebold
6,772,756 B2	8/2004	Shayan	7,451,877 B2	11/2008	Koga et al.
D495,599 S	9/2004	Biesecker	D585,077 S	1/2009	Sheba et al.
6,799,576 B2	10/2004	Farr	7,488,171 B2	2/2009	St. Charles et al.
6,803,545 B2	10/2004	Blake et al.	D588,741 S	3/2009	Murdaugh, III et al.
6,803,744 B1	10/2004	Sabo	D589,941 S	4/2009	Maier et al.
6,805,545 B2	10/2004	Slaboden	D590,988 S	4/2009	Hon
6,810,883 B2	11/2004	Felter et al.	D590,989 S	4/2009	Hon
D500,301 S	12/2004	Deguchi	D590,990 S	4/2009	Hon
D500,302 S	12/2004	Deguchi	D590,991 S	4/2009	Hon
6,827,573 B2	12/2004	St. Charles et al.	D591,758 S	5/2009	Lee
6,854,470 B1	2/2005	Pu	7,530,352 B2	5/2009	Childers et al.
6,874,507 B2	4/2005	Farr	7,546,703 B2	6/2009	Johnske et al.
6,889,687 B1	5/2005	Olsson	D599,670 S	9/2009	Qin
D505,922 S	6/2005	Mayo et al.	7,581,540 B2	9/2009	Hale et al.
D506,447 S	6/2005	Mayo et al.	7,621,403 B2	11/2009	Althoff et al.
D506,731 S	6/2005	Mayo et al.	D605,509 S	12/2009	Leonardis
6,909,840 B2	6/2005	Harwig et al.	D606,505 S	12/2009	Seflic et al.
D507,244 S	7/2005	Mayo et al.	7,633,270 B2	12/2009	Wong et al.
6,923,327 B1	8/2005	Cohen	7,644,823 B2	1/2010	Gelardi et al.
6,923,890 B2	8/2005	Ricatto et al.	D610,588 S	2/2010	Chen

US D842,536 S

D611,409 S	3/2010	Green et al.	8,387,612 B2	3/2013	Damani et al.
7,669,596 B2	3/2010	Alston	8,393,331 B2	3/2013	Hon
D616,753 S *	6/2010	Beam D9/420	8,402,978 B2	3/2013	Karles et al.
7,726,320 B2	6/2010	Robinson et al.	8,424,539 B2	4/2013	Braunshiteyn et al.
7,753,055 B2	7/2010	Bryman	D681,445 S	5/2013	van Landsveld et al.
D621,357 S	8/2010	Dong	D682,090 S	5/2013	Scatterday
7,767,698 B2	8/2010	Warchol et al.	D682,698 S	5/2013	Young
D624,238 S	9/2010	Turner	D682,841 S	5/2013	Suetake et al.
D624,378 S	9/2010	Wysopal	8,443,534 B2	5/2013	Goodfellow et al.
7,793,860 B2	9/2010	Bankers et al.	D684,683 S	6/2013	Curti et al.
7,793,861 B2	9/2010	Bankers et al.	8,464,867 B2	6/2013	Holloway et al.
7,801,573 B2	9/2010	Yazdi et al.	D686,336 S	7/2013	Horian
D624,880 S	10/2010	Felegy, Jr. et al.	D686,987 S	7/2013	Vanstone et al.
7,813,832 B2	10/2010	Sundar	D687,042 S	7/2013	Yoneta et al.
7,814,905 B2	10/2010	Schuler et al.	8,479,747 B2	7/2013	O'Connell
7,815,332 B1	10/2010	Smith	8,490,629 B1	7/2013	Shenassa et al.
D627,962 S	11/2010	Mudrick	8,495,998 B2	7/2013	Schennum
7,832,397 B2	11/2010	Lipowicz	8,499,766 B1	8/2013	Newton
7,832,410 B2	11/2010	Hon	8,511,318 B2	8/2013	Hon
7,845,359 B2	12/2010	Montaser	D689,818 S	9/2013	Sasada
D631,055 S	1/2011	Gilbert et al.	D690,461 S	9/2013	Chen
D631,458 S	1/2011	Liao et al.	8,539,959 B1	9/2013	Scatterday
7,886,507 B2	2/2011	McGuinness, Jr.	8,541,401 B2	9/2013	Mishra et al.
7,891,666 B2	2/2011	Kuenzler et al.	D691,324 S	10/2013	Saliman
D634,065 S	3/2011	Borushek et al.	D692,615 S	10/2013	Verleur
D634,735 S	3/2011	Maier	8,550,069 B2	10/2013	Alelov
7,905,230 B2	3/2011	Schuler et al.	8,552,691 B2	10/2013	Wu
7,905,236 B2	3/2011	Bryman et al.	D693,054 S	11/2013	Verleur
7,913,686 B2	3/2011	Hughes et al.	8,578,942 B2	11/2013	Schennum
D639,303 S	6/2011	Ni et al.	8,578,943 B2	11/2013	Luan et al.
D639,782 S	6/2011	Kim	D695,450 S	12/2013	Benassayag et al.
D641,718 S	7/2011	Sakai	D696,051 S	12/2013	Scatterday
D642,330 S	7/2011	Turner	8,596,460 B2	12/2013	Scatterday
D643,807 S	8/2011	Jiang	8,646,462 B2	2/2014	Yamada et al.
D644,375 S	8/2011	Zhou	D700,572 S	3/2014	Esses
7,987,846 B2	8/2011	Hale et al.	8,671,952 B2	3/2014	Winterson et al.
7,988,034 B2	8/2011	Pezzoli	8,678,012 B2	3/2014	Li et al.
8,003,080 B2	8/2011	Rabinowitz et al.	8,689,789 B2	4/2014	Andrus et al.
D645,817 S *	9/2011	Sasada D13/108	8,689,805 B2	4/2014	Hon
D647,247 S	10/2011	Jones	8,695,794 B2	4/2014	Scatterday
8,042,550 B2	10/2011	Urtsev et al.	8,707,965 B2	4/2014	Newton
D649,708 S	11/2011	Oneil	D704,629 S	5/2014	Liu
D649,932 S	12/2011	Symons	D704,634 S	5/2014	Eidelman et al.
D650,737 S	12/2011	Hamilton	D705,719 S	5/2014	Wong
8,079,361 B2	12/2011	Schuler et al.	D705,918 S	5/2014	Robinson et al.
8,079,371 B2	12/2011	Robinson et al.	8,714,150 B2	5/2014	Alelov
8,080,975 B2	12/2011	Bessa et al.	8,714,161 B2	5/2014	Liu
8,091,558 B2	1/2012	Martzel	8,733,345 B2	5/2014	Siller
D653,803 S	2/2012	Timmermans	8,733,346 B2	5/2014	Rinker
D656,496 S	3/2012	Andre et al.	D707,389 S	6/2014	Liu
8,141,701 B2	3/2012	Hodges	D707,627 S	6/2014	Brunner et al.
8,156,944 B2	4/2012	Han	8,739,788 B2	6/2014	Yomtov
8,157,918 B2	4/2012	Becker et al.	8,741,348 B2	6/2014	Hansson et al.
8,170,623 B2	5/2012	Dorogusker et al.	8,752,545 B2	6/2014	Buchberger
D661,889 S	6/2012	Wu	8,752,557 B2	6/2014	Lipowicz
D661,991 S	6/2012	Brummelhuis et al.	8,757,169 B2	6/2014	Gysland
8,205,622 B2	6/2012	Pan	D708,727 S	7/2014	Postma
D664,146 S	7/2012	Hoehn et al.	8,770,187 B2	7/2014	Murphy
D664,636 S	7/2012	Robinson et al.	8,781,307 B2	7/2014	Buzzetti
D664,920 S	8/2012	Huang	8,790,556 B2	7/2014	Bundren et al.
D665,346 S	8/2012	Kumagai et al.	8,794,231 B2	8/2014	Thorens et al.
D665,734 S	8/2012	Fitch et al.	8,794,244 B2	8/2014	Hammel et al.
8,251,060 B2	8/2012	White et al.	8,794,245 B1	8/2014	Scatterday
8,282,995 B2	10/2012	Calzia et al.	8,794,434 B2	8/2014	Scatterday et al.
D670,272 S	11/2012	Suzuki	8,807,140 B1	8/2014	Scatterday
D670,659 S	11/2012	Ishikawa et al.	8,809,261 B2	8/2014	Elsohly et al.
8,308,624 B2	11/2012	Travers et al.	8,813,747 B2	8/2014	Gibson et al.
8,314,235 B2	11/2012	Dixit et al.	8,813,759 B1	8/2014	Horian
D672,714 S	12/2012	Brandys et al.	8,820,330 B2	9/2014	Bellinger et al.
D672,715 S	12/2012	Brunner et al.	8,829,395 B2	9/2014	Bao
8,322,350 B2	12/2012	Lipowicz	8,851,068 B2	10/2014	Cohen et al.
D674,182 S	1/2013	Copeland et al.	8,851,081 B2	10/2014	Fernando et al.
D674,748 S	1/2013	Ferber et al.	8,851,083 B2	10/2014	Oglesby et al.
8,344,693 B2	1/2013	Budziszek et al.	8,857,446 B2	10/2014	Wu
D676,741 S	2/2013	van Landsveld et al.	8,863,752 B2	10/2014	Hon
8,371,310 B2	2/2013	Brenneise	8,869,792 B1	10/2014	Lee
8,375,947 B2	2/2013	Alston et al.	8,881,737 B2	11/2014	Collett et al.
8,375,957 B2	2/2013	Hon	8,881,738 B2	11/2014	Bryman
8,381,739 B2	2/2013	Gonda	8,893,726 B2	11/2014	Hon

US D842,536 S

8,897,628 B2	11/2014	Conley et al.	9,078,473 B2	7/2015	Worm et al.
D718,621 S	12/2014	Mitchell et al.	9,078,474 B2	7/2015	Thompson
D718,723 S	12/2014	Clymer et al.	9,078,475 B2	7/2015	Li et al.
D718,933 S	12/2014	Brown, Jr.	9,089,166 B1	7/2015	Scatterday
D719,701 S	12/2014	Scatterday	9,089,168 B2	7/2015	Liu
D720,095 S	12/2014	Alima	9,090,173 B2	7/2015	Oishi
D720,496 S	12/2014	Alima	D736,706 S	8/2015	Huang et al.
D720,497 S	12/2014	Alima	D736,995 S	8/2015	Recio
8,899,238 B2	12/2014	Robinson et al.	D737,508 S	8/2015	Liu
8,899,240 B2	12/2014	Mass	9,095,174 B2	8/2015	Capuano
8,905,040 B2	12/2014	Scatterday et al.	9,095,175 B2	8/2015	Terry et al.
8,910,630 B2	12/2014	Todd	9,099,873 B2	8/2015	Xiang
8,910,639 B2	12/2014	Chang et al.	9,101,729 B2	8/2015	Liu
8,910,640 B2	12/2014	Sears et al.	9,113,659 B2	8/2015	Liu
8,910,641 B2	12/2014	Hon	D737,566 S	9/2015	Gaddis
8,910,783 B2	12/2014	Liu	D738,038 S *	9/2015	Smith D27/170
8,915,254 B2	12/2014	Monsees et al.	D739,973 S *	9/2015	Chao D13/108
8,919,561 B2	12/2014	Boisseau	9,131,733 B2	9/2015	Liu
D721,202 S	1/2015	Liu	D741,001 S	10/2015	Alarcon et al.
D721,577 S	1/2015	Scatterday	D741,002 S	10/2015	Liu
8,925,555 B2	1/2015	Monsees et al.	D741,541 S	10/2015	Liu
8,928,277 B2	1/2015	Xiang et al.	D742,063 S	10/2015	Recio
8,931,492 B2	1/2015	Scatterday	D742,064 S	10/2015	Leidel
D721,972 S	2/2015	Brewer et al.	9,155,336 B2	10/2015	Liu
D722,023 S	2/2015	Brunner et al.	9,166,424 B2	10/2015	Oakley, Jr.
8,948,578 B2	2/2015	Buchberger	9,167,849 B2	10/2015	Adamic
8,950,395 B2	2/2015	Schennum	9,167,850 B2	10/2015	Liu
8,955,522 B1	2/2015	Bowen et al.	9,167,852 B2	10/2015	Xiu
8,960,199 B2	2/2015	Zhuang et al.	9,167,853 B2	10/2015	Xiang
8,961,492 B2	2/2015	Imran et al.	D742,492 S	11/2015	Robinson et al.
8,963,725 B2	2/2015	Xiang	D742,624 S	11/2015	Meyers
D723,735 S	3/2015	Liu	D743,099 S	11/2015	Oglesby
D723,736 S	3/2015	Liu	D744,159 S	11/2015	Lukas
D723,737 S	3/2015	Liu	9,185,937 B2	11/2015	Liu
D724,037 S	3/2015	Yoshioka	9,197,726 B2	11/2015	Stanimirovic et al.
D725,310 S	3/2015	Eksouzian	D744,342 S	12/2015	Blasko et al.
D725,823 S	3/2015	Scatterday et al.	D744,419 S	12/2015	Bowen et al.
8,967,382 B2	3/2015	Liu	D744,696 S	12/2015	Malhi
8,973,587 B2	3/2015	Liu	D745,004 S	12/2015	Kim
8,975,764 B1	3/2015	Abehasera	D745,388 S	12/2015	Taylor
8,978,663 B2	3/2015	Newton	D746,291 S	12/2015	Solomon et al.
8,991,402 B2	3/2015	Bowen et al.	9,198,463 B2	12/2015	Liu
8,993,836 B2	3/2015	Tissier et al.	9,198,464 B2	12/2015	Liu
D726,727 S	4/2015	Holz et al.	9,198,466 B2	12/2015	Liu
9,004,073 B2	4/2015	Tucker et al.	9,204,670 B2	12/2015	Liu
9,010,335 B1	4/2015	Scatterday	9,215,895 B2	12/2015	Bowen et al.
9,016,274 B1	4/2015	White	9,220,302 B2	12/2015	DePiano et al.
9,018,899 B2	4/2015	Xiang	9,220,303 B2	12/2015	Li et al.
D728,855 S	5/2015	Liu	D747,035 S	1/2016	Moradian
D729,030 S	5/2015	Novick et al.	D747,265 S	1/2016	Marini
D729,277 S	5/2015	Uchida	D747,546 S	1/2016	Liu
D729,366 S	5/2015	Kauss et al.	D747,603 S	1/2016	Gaddis
D729,439 S	5/2015	Scatterday	D747,722 S	1/2016	Webb
D729,444 S	5/2015	Leidel	D747,852 S	1/2016	Meyers
D729,445 S	5/2015	Leidel	D748,329 S	1/2016	Bagai et al.
D730,282 S	5/2015	Miller et al.	9,226,525 B2	1/2016	Liu
D730,571 S	5/2015	Chen	9,226,526 B2	1/2016	Liu
D730,572 S	5/2015	Leidel	9,233,217 B2	1/2016	Jones
9,022,026 B2	5/2015	Fang	9,240,695 B2	1/2016	Xiang
9,022,039 B2	5/2015	Hearn	9,240,697 B2	1/2016	Xiang
9,025,291 B2	5/2015	Xiang	D748,852 S	2/2016	Wu
9,028,808 B2	5/2015	Huland	D748,853 S	2/2016	Seibel et al.
9,032,968 B2	5/2015	Glasberg et al.	D749,260 S	2/2016	Wu
9,038,626 B2	5/2015	Yamada et al.	D749,261 S	2/2016	Chen
9,038,642 B2	5/2015	Liu	D749,505 S	2/2016	Verleur et al.
D731,114 S	6/2015	Leidel	D749,510 S	2/2016	Liu
D733,050 S	6/2015	Chiang	D749,781 S	2/2016	Lane
D733,142 S	6/2015	Solomon et al.	D750,320 S	2/2016	Verleur et al.
D733,356 S	6/2015	Leidel	D750,321 S	2/2016	Chen
9,046,278 B2	6/2015	Koller	9,247,773 B2	2/2016	Memari et al.
9,050,431 B2	6/2015	Turner et al.	9,254,002 B2	2/2016	Chong et al.
9,055,617 B2	6/2015	Thorens et al.	9,254,005 B2	2/2016	Liu
9,055,770 B2	6/2015	Liu	9,255,277 B2	2/2016	Bakker et al.
9,060,388 B2	6/2015	Liu	D750,835 S	3/2016	Wei
9,060,548 B2	6/2015	Zheng et al.	D751,250 S	3/2016	Vuong
9,066,543 B2	6/2015	Cameron	D751,527 S	3/2016	Hinokio et al.
9,072,321 B2	7/2015	Liu	D751,755 S	3/2016	Van Riper
9,072,322 B2	7/2015	Liu	D751,757 S	3/2016	Stern
9,078,472 B2	7/2015	Liu	D751,984 S	3/2016	Lin

US D842,536 S

D752,277 S	3/2016	Liu	D762,326 S	7/2016	Liu
D752,278 S	3/2016	Verleur et al.	9,380,810 B2	7/2016	Rose et al.
D752,279 S	3/2016	Liu	9,380,812 B2	7/2016	Chung
D752,280 S	3/2016	Verleur et al.	9,383,053 B2	7/2016	Liu
D752,281 S	3/2016	Alima	9,385,554 B2	7/2016	Xiang
D752,282 S	3/2016	Doster	9,386,803 B2	7/2016	Burke et al.
D752,283 S	3/2016	Doster	D763,203 S	8/2016	Ikegaya et al.
D752,284 S	3/2016	Doster	D763,204 S	8/2016	Ikegaya et al.
D752,285 S	3/2016	Doster	D763,502 S	8/2016	Verleur et al.
D752,286 S	3/2016	Doster	D764,098 S	8/2016	Liu
D752,808 S	3/2016	Hearn	D764,703 S	8/2016	Liu
9,271,525 B2	3/2016	Liu	D765,307 S	8/2016	Liu
9,271,526 B2	3/2016	Liu	D765,308 S	8/2016	Liu
9,271,529 B2	3/2016	Alima	D765,309 S	8/2016	Liu
9,272,103 B2	3/2016	Storz	9,408,416 B2	8/2016	Monsees et al.
9,277,768 B2	3/2016	Xiu	9,413,180 B2	8/2016	Liu
9,277,769 B2	3/2016	Liu	9,414,627 B2	8/2016	Liu
9,281,705 B2	3/2016	Xiang	9,414,628 B2	8/2016	Liu
9,282,772 B2	3/2016	Tucker et al.	9,415,929 B2	8/2016	Liu
9,282,773 B2	3/2016	Greim et al.	9,417,107 B2	8/2016	Xiang
9,289,014 B2	3/2016	Tucker et al.	9,420,831 B2	8/2016	Liu
9,295,286 B2	3/2016	Shin	9,427,022 B2	8/2016	Levin et al.
D753,090 S	4/2016	Langhammer et al.	9,427,023 B2	8/2016	Liu
D753,338 S	4/2016	Chen	9,427,024 B2	8/2016	Liu
D753,873 S	4/2016	Schuessler	9,427,025 B2	8/2016	Liu
D753,874 S	4/2016	Moreno Medina et al.	9,427,026 B2	8/2016	Wu
D754,917 S	4/2016	Salem	D765,907 S	9/2016	Liu
D754,919 S	4/2016	Alarcon et al.	D766,503 S	9/2016	Liu
9,301,545 B2	4/2016	Li et al.	D766,873 S	9/2016	Washio
9,301,549 B2	4/2016	Liu	D767,200 S	9/2016	Liu
9,302,800 B2	4/2016	Holmes et al.	D767,201 S	9/2016	Starr
9,302,825 B2	4/2016	Liu	D767,820 S	9/2016	Jordan et al.
9,308,336 B2	4/2016	Newton	D767,821 S	9/2016	Clark et al.
9,312,687 B2	4/2016	Xiang	D767,822 S	9/2016	Jordan et al.
9,315,890 B1	4/2016	Frick et al.	9,433,242 B1	9/2016	Buffone
9,320,300 B2	4/2016	Hon	9,438,049 B2	9/2016	Xiang
D755,057 S	5/2016	Mutter	9,438,051 B2	9/2016	Firman, II et al.
D755,506 S	5/2016	Neely, III et al.	9,439,455 B2	9/2016	Alarcon et al.
D755,733 S	5/2016	Ikegaya et al.	9,439,456 B2	9/2016	Liu
D755,735 S	5/2016	Kashimoto	9,440,035 B2	9/2016	Chung
D756,030 S	5/2016	Chen	9,451,790 B2	9/2016	Liu
D756,031 S	5/2016	Wu	9,451,793 B2	9/2016	Zhou
D756,559 S	5/2016	Li	9,455,579 B2	9/2016	Xiang
D757,352 S	5/2016	Bagai	D768,068 S	10/2016	Chen
D757,353 S	5/2016	Nunnally et al.	D768,331 S	10/2016	Chen
D757,357 S	5/2016	Helfrich	D768,920 S	10/2016	Jones et al.
D757,690 S	5/2016	Lee et al.	D768,980 S	10/2016	Alexander
D757,994 S	5/2016	Moradian	D769,518 S	10/2016	Liu
D757,995 S	5/2016	Liu	D769,519 S	10/2016	Chen
D758,004 S	5/2016	Freshwater et al.	D769,520 S	10/2016	Hua
9,326,547 B2	5/2016	Tucker et al.	D769,830 S	10/2016	Clymer et al.
9,326,549 B2	5/2016	Hon	D770,088 S	10/2016	Abadi et al.
9,332,787 B2	5/2016	Liu	9,456,632 B2	10/2016	Hon
9,345,269 B2	5/2016	Liu	9,456,633 B2	10/2016	Liu
9,350,102 B2	5/2016	Wu	9,456,634 B2	10/2016	Wang et al.
9,350,178 B2	5/2016	Xiang	9,459,021 B2	10/2016	Greim et al.
9,350,181 B2	5/2016	Xiang	9,462,832 B2	10/2016	Lord
9,351,522 B2	5/2016	Safari	9,465,081 B2	10/2016	Xiang
D758,647 S	6/2016	Liu	9,474,305 B2	10/2016	Liu
D758,649 S	6/2016	Liu	D770,395 S	11/2016	Clymer et al.
D758,650 S	6/2016	Wu	D770,676 S	11/2016	Bennett et al.
D759,031 S	6/2016	Ozolins et al.	D770,678 S	11/2016	Shin
D759,297 S	6/2016	Liu	D770,679 S	11/2016	Weigensberg
D759,303 S	6/2016	Afridi	D771,219 S	11/2016	Gilbarte
D760,431 S	6/2016	Liu	D771,307 S	11/2016	Wu
9,357,802 B2	6/2016	Liu	D771,308 S	11/2016	Saydar et al.
9,360,379 B2	6/2016	Liu	D772,477 S	11/2016	Shin
9,364,025 B2	6/2016	Liu	D772,478 S	11/2016	Liu
9,364,026 B2	6/2016	Liu	D772,479 S	11/2016	Stowers et al.
9,364,027 B2	6/2016	Hon	D772,480 S	11/2016	Hua
9,364,800 B2	6/2016	Dubief	D772,879 S	11/2016	Eliyahu
9,379,364 B2	6/2016	Alima	D773,114 S *	11/2016	Leidel D27/163
D760,645 S	7/2016	Chen	D773,115 S	11/2016	Liu
D760,952 S	7/2016	Mayor	D773,116 S	11/2016	Liu et al.
D761,488 S	7/2016	Alarcon et al.	9,480,285 B2	11/2016	Liu
D761,999 S	7/2016	Liu	9,480,286 B2	11/2016	Liu
D762,000 S	7/2016	Liu	9,497,993 B2	11/2016	Vallar
D762,001 S	7/2016	Liu	9,497,994 B2	11/2016	Liu
D762,003 S	7/2016	Lomeli	9,497,995 B2	11/2016	Liu

US D842,536 S

9,497,997 B2	11/2016	Wu	9,603,386 B2	3/2017	Xiang
9,497,998 B2	11/2016	Chen	9,603,387 B2	3/2017	Liu
9,497,999 B2	11/2016	Lord	9,603,389 B2	3/2017	Chen
9,498,001 B2	11/2016	Wu	9,603,390 B2	3/2017	Li et al.
9,498,002 B1	11/2016	Soreide	D784,609 S	4/2017	Liu
9,498,588 B2	11/2016	Benassayag et al.	D785,234 S	4/2017	Liu
9,502,917 B2	11/2016	Xiang	D785,237 S	4/2017	Wu
9,504,278 B2	11/2016	Liu	9,609,893 B2	4/2017	Novak, III et al.
9,504,279 B2	11/2016	Chen	9,615,605 B2	4/2017	Liu
D773,391 S	12/2016	Haarburger et al.	9,615,606 B2	4/2017	Liu
D773,727 S *	12/2016	Eksouzian D27/101	9,615,607 B2	4/2017	Liu
D773,729 S	12/2016	Jordan et al.	9,620,958 B2	4/2017	Liu
D774,247 S	12/2016	Chen	9,622,511 B2	4/2017	Zhu
D774,248 S	12/2016	Jordan et al.	9,623,592 B2	4/2017	Liu
D774,514 S	12/2016	Turksu et al.	9,627,661 B2	4/2017	Liu
D774,693 S	12/2016	Liu	9,629,391 B2	4/2017	Dube et al.
D774,892 S	12/2016	Liu	9,629,394 B2	4/2017	Aronie et al.
D775,412 S	12/2016	Di Bari	D785,859 S	5/2017	Pang
D775,413 S	12/2016	Liu	D785,862 S	5/2017	Wu
9,510,624 B2	12/2016	Li et al.	D786,789 S	5/2017	Jordan et al.
9,516,898 B2	12/2016	Liu	D787,114 S	5/2017	Scott
9,521,867 B2	12/2016	Xiang	D788,362 S	5/2017	Qiu
9,526,272 B2	12/2016	Liu	9,635,886 B2	5/2017	Tu
9,526,273 B2	12/2016	Liu	9,641,208 B2	5/2017	Sela et al.
9,531,183 B2	12/2016	Xiang	9,642,396 B2	5/2017	Liu
D775,762 S	1/2017	Chen	9,642,397 B2	5/2017	Dai et al.
D776,051 S	1/2017	Wang	9,645,134 B1	5/2017	Farmen et al.
D776,162 S	1/2017	Beck et al.	9,648,905 B2	5/2017	Levitz et al.
D776,270 S	1/2017	Wilcox et al.	9,648,908 B1	5/2017	Rinehart et al.
D776,338 S *	1/2017	Lomeli D27/163	9,648,909 B2	5/2017	Zhou et al.
D776,340 S	1/2017	Seibel et al.	9,655,383 B2	5/2017	Holzherr et al.
D776,659 S	1/2017	Hou	9,655,890 B2	5/2017	Hearn et al.
D777,372 S	1/2017	Liu	9,661,878 B2	5/2017	Liu
D777,976 S	1/2017	Mahlmeister	9,663,266 B2	5/2017	Schwester
9,532,598 B2	1/2017	Liu	D788,697 S	6/2017	Verleur et al.
9,532,599 B2	1/2017	Liu	D790,122 S	6/2017	Hawes et al.
9,532,601 B2	1/2017	Liu	D790,126 S	6/2017	Bennett et al.
9,532,602 B2	1/2017	Liu	D790,129 S	6/2017	Bennett et al.
9,532,604 B2	1/2017	Conley et al.	D790,766 S	6/2017	Li
9,532,605 B2	1/2017	Yamada et al.	9,668,517 B2	6/2017	Liu
9,538,781 B2	1/2017	Zheng	9,668,518 B2	6/2017	Esses
9,538,783 B2	1/2017	Xiang	9,668,519 B2	6/2017	Mishra et al.
9,538,787 B2	1/2017	Liu	9,668,520 B2	6/2017	Boldrini
9,538,789 B2	1/2017	Liu	9,668,521 B2	6/2017	Kuczaj
9,545,489 B2	1/2017	Turner et al.	9,668,522 B2	6/2017	Memari et al.
9,549,572 B2	1/2017	Dincer et al.	9,668,523 B2	6/2017	Tucker et al.
9,549,573 B2	1/2017	Monsees et al.	9,675,108 B2	6/2017	Liu
9,554,596 B2	1/2017	Liu	9,675,113 B2	6/2017	Liu
9,554,597 B2	1/2017	Liu	9,675,114 B2	6/2017	Timmermans
9,555,203 B2	1/2017	Terry et al.	9,675,115 B2	6/2017	Liu
D778,493 S	2/2017	Scott	9,675,116 B2	6/2017	Liu
D778,831 S	2/2017	Chen	9,675,117 B2	6/2017	Li et al.
D779,677 S	2/2017	Chen	9,675,118 B2	6/2017	Chen
D779,719 S	2/2017	Qiu	9,681,687 B2	6/2017	Liu
D780,179 S	2/2017	Bae et al.	9,681,688 B1	6/2017	Rinehart et al.
D780,372 S	2/2017	Liu	9,682,203 B2	6/2017	Dahne et al.
D780,373 S	2/2017	Bennett et al.	9,682,204 B2	6/2017	Matsumoto et al.
9,560,882 B2	2/2017	Xiang	9,682,800 B2	6/2017	Xiang
9,565,873 B2	2/2017	Zheng	9,687,025 B2	6/2017	Cyphert et al.
9,565,876 B2	2/2017	Tsai	9,687,027 B2	6/2017	Poston et al.
9,572,372 B2	2/2017	Liu	9,687,028 B2	6/2017	Park
9,572,373 B2	2/2017	Chen	9,687,029 B2	6/2017	Liu
9,572,374 B2	2/2017	Gabbay	D792,021 S	7/2017	Beer et al.
9,573,751 B2	2/2017	Liu	D792,022 S	7/2017	Li
9,578,002 B2	2/2017	Wu	D792,644 S	7/2017	Jordan et al.
9,578,898 B2	2/2017	Liu	D793,004 S	7/2017	Liu
D780,990 S	3/2017	Liu	9,693,584 B2	7/2017	Hearn et al.
D780,991 S	3/2017	Liu	9,693,586 B2	7/2017	Liu
D782,108 S	3/2017	Jordan et al.	9,693,587 B2	7/2017	Plojoux et al.
D782,728 S	3/2017	Pinder	9,693,588 B2	7/2017	Zhu
D782,729 S	3/2017	Wright et al.	9,695,033 B1	7/2017	Alshouse et al.
9,591,876 B2	3/2017	Alima	9,700,074 B2	7/2017	Liu
9,596,881 B2	3/2017	Chiolini et al.	9,700,075 B2	7/2017	Liu
9,596,884 B2	3/2017	Liu	9,700,076 B2	7/2017	Xiang
9,596,885 B2	3/2017	Liu	9,713,345 B2	7/2017	Farine et al.
9,596,886 B2	3/2017	Liu	9,713,346 B2	7/2017	Hon
9,596,887 B2	3/2017	Newton	9,714,878 B2	7/2017	Powers et al.
9,602,646 B2	3/2017	Stanimirovic et al.	D793,620 S	8/2017	Bennett et al.
9,603,198 B2	3/2017	Liu	9,717,274 B2	8/2017	Daehne et al.

US D842,536 S

9,717,275	B2	8/2017	Liu	2006/0054676	A1	3/2006	Wischusen
9,717,276	B2	8/2017	Brammer et al.	2006/0102175	A1	5/2006	Nelson
9,717,277	B2	8/2017	Mironov	2006/0150991	A1	7/2006	Lee
9,717,278	B2	8/2017	Hon	2006/0185687	A1	8/2006	Hearn et al.
9,717,279	B2	8/2017	Hon	2006/0191546	A1	8/2006	Takano et al.
9,723,872	B2	8/2017	Liu	2006/0191548	A1	8/2006	Strickland et al.
9,723,873	B2	8/2017	Liu	2006/0191594	A1	8/2006	Py
9,723,874	B2	8/2017	Liu	2006/0196518	A1	9/2006	Hon
9,723,875	B2	8/2017	Liu	2006/0254948	A1	11/2006	Herbert et al.
9,723,876	B2	8/2017	Cadieux et al.	2006/0255105	A1	11/2006	Sweet
9,723,877	B2	8/2017	Wong et al.	2007/0006889	A1	1/2007	Kobal et al.
9,730,471	B2	8/2017	Li et al.	2007/0045288	A1	3/2007	Nelson
9,738,622	B2	8/2017	Dull et al.	2007/0062548	A1	3/2007	Horstmann et al.
9,763,478	B2	9/2017	Cameron et al.	2007/0074734	A1	4/2007	Braunshsteyn et al.
9,770,055	B2	9/2017	Cameron et al.	2007/0089757	A1	4/2007	Bryman
9,772,216	B2	9/2017	Poole et al.	2007/0098148	A1	5/2007	Sherman
D799,746	S *	10/2017	Leidel D27/163	2007/0102013	A1	5/2007	Adams et al.
9,775,380	B2	10/2017	Fernando et al.	2007/0125765	A1	6/2007	Nelson
9,802,011	B2	10/2017	Davidson et al.	2007/0144514	A1	6/2007	Yeates et al.
9,806,549	B2	10/2017	Liberti et al.	2007/0163610	A1	7/2007	Lindell et al.
D802,206	S *	11/2017	Huang D27/101	2007/0169773	A1	7/2007	Rock
9,809,567	B2	11/2017	Willis et al.	2007/0191756	A1	8/2007	Tapper
9,814,263	B2	11/2017	Cochand et al.	2007/0215164	A1	9/2007	Mehio
9,814,272	B2	11/2017	Li et al.	2007/0215168	A1	9/2007	Banerjee et al.
9,820,508	B2	11/2017	Arnel et al.	2007/0235046	A1	10/2007	Gedevanishvili
D806,311	S *	12/2017	Smith D27/162	2007/0267033	A1	11/2007	Mishra et al.
9,930,915	B2	4/2018	Worm et al.	2007/0277816	A1	12/2007	Morrison et al.
2001/0015209	A1	8/2001	Zielke	2007/0280652	A1	12/2007	Williams
2001/0032643	A1	10/2001	Hochrainer et al.	2007/0283972	A1	12/2007	Monsees et al.
2001/0032795	A1	10/2001	Weinstein et al.	2007/0295347	A1	12/2007	Paine et al.
2001/0052480	A1	12/2001	Kawaguchi et al.	2008/0000763	A1	1/2008	Cove
2002/0029779	A1	3/2002	Schmidt et al.	2008/0023003	A1	1/2008	Rosenthal
2002/0043554	A1	4/2002	White et al.	2008/0029095	A1	2/2008	Esser
2002/0078951	A1	6/2002	Nichols et al.	2008/0065176	A1	3/2008	Zhang et al.
2002/0088469	A1	7/2002	Rennecamp	2008/0092912	A1	4/2008	Robinson et al.
2002/0142291	A1	10/2002	Bauer et al.	2008/0138423	A1	6/2008	Gonda
2002/0175164	A1	11/2002	Dees et al.	2008/0149118	A1	6/2008	Oglesby et al.
2003/0004426	A1	1/2003	Melker et al.	2008/0207276	A1	8/2008	Burrell
2003/0005926	A1	1/2003	Jones et al.	2008/0214103	A1	9/2008	Nelson et al.
2003/0089377	A1	5/2003	Hajaligol et al.	2008/0216828	A1	9/2008	Wensley et al.
2003/0149372	A1	8/2003	Smith et al.	2008/0241255	A1	10/2008	Rose et al.
2003/0150451	A1	8/2003	Shayan	2008/0257367	A1	10/2008	Paterno et al.
2003/0154991	A1	8/2003	Fournier et al.	2008/0276947	A1	11/2008	Martzel
2004/0031495	A1	2/2004	Steinberg	2008/0286340	A1	11/2008	Andersson et al.
2004/0050382	A1	3/2004	Goodchild	2008/0302375	A1	12/2008	Andersson et al.
2004/0099266	A1	5/2004	Cross et al.	2009/0004249	A1	1/2009	Gonda
2004/0129280	A1	7/2004	Woodson et al.	2009/0071469	A1	3/2009	Abrams
2004/0149296	A1	8/2004	Rostami et al.	2009/0095287	A1	4/2009	Emarlou
2004/0149624	A1	8/2004	Wischusen et al.	2009/0095311	A1	4/2009	Han
2004/0173224	A1	9/2004	Burgard et al.	2009/0111287	A1	4/2009	Lindberg et al.
2004/0173229	A1	9/2004	Crooks et al.	2009/0126745	A1	5/2009	Hon
2004/0182403	A1	9/2004	Andersson et al.	2009/0133691	A1	5/2009	Yamada et al.
2004/0191322	A1	9/2004	Hansson	2009/0133703	A1	5/2009	Strickland et al.
2004/0206350	A1	10/2004	Alston et al.	2009/0133704	A1	5/2009	Strickland et al.
2004/0221857	A1	11/2004	Dominguez	2009/0141196	A1	6/2009	Basner et al.
2004/0226569	A1	11/2004	Yang et al.	2009/0151717	A1	6/2009	Bowen et al.
2004/0237974	A1	12/2004	Min	2009/0188490	A1	7/2009	Han
2005/0016533	A1	1/2005	Schuler et al.	2009/0192443	A1	7/2009	Collins, Jr.
2005/0016549	A1	1/2005	Banerjee et al.	2009/0230117	A1	9/2009	Fernando et al.
2005/0016550	A1	1/2005	Katase	2009/0255534	A1	10/2009	Paterno
2005/0029137	A1	2/2005	Wang	2009/0260641	A1	10/2009	Monsees et al.
2005/0034723	A1	2/2005	Bennett et al.	2009/0260642	A1	10/2009	Monsees et al.
2005/0051453	A1	3/2005	Schuler et al.	2009/0267252	A1	10/2009	Ikeyama
2005/0056280	A1	3/2005	Alston et al.	2009/0272379	A1	11/2009	Thorens et al.
2005/0061759	A1	3/2005	Doucette	2009/0283103	A1	11/2009	Nielsen et al.
2005/0069831	A1	3/2005	St Charles et al.	2009/0288668	A1	11/2009	Inagaki
2005/0081601	A1	4/2005	Lawson	2009/0288669	A1	11/2009	Hutchens
2005/0090798	A1	4/2005	Clark et al.	2009/0293892	A1	12/2009	Williams et al.
2005/0118545	A1	6/2005	Wong	2009/0293895	A1	12/2009	Axelsson et al.
2005/0145533	A1	7/2005	Seligson	2009/0302019	A1	12/2009	Selenski et al.
2005/0161467	A1	7/2005	Jones	2009/0308387	A1	12/2009	Andersen et al.
2005/0172976	A1	8/2005	Newman et al.	2010/0000672	A1	1/2010	Fogle
2005/0229918	A1	10/2005	Shim	2010/0006092	A1	1/2010	Hale et al.
2005/0236006	A1	10/2005	Cowan	2010/0024834	A1	2/2010	Oglesby et al.
2005/0244521	A1	11/2005	Strickland et al.	2010/0031968	A1	2/2010	Sheikh et al.
2005/0268908	A1	12/2005	Bonney et al.	2010/0059073	A1	3/2010	Hoffmann et al.
2005/0268911	A1	12/2005	Cross et al.	2010/0156193	A1	6/2010	Rhodes et al.
2006/0016453	A1	1/2006	Kim	2010/0163063	A1	7/2010	Fernando et al.
2006/0018840	A1	1/2006	Lechuga-Ballesteros et al.	2010/0163065	A1	7/2010	Chang

US D842,536 S

2010/0186757	A1	7/2010	Crooks et al.	2012/0298676	A1	11/2012	Cooks
2010/0200006	A1	8/2010	Robinson et al.	2012/0312313	A1	12/2012	Frija
2010/0200008	A1	8/2010	Taieb	2012/0318882	A1	12/2012	Abehasera
2010/0236562	A1	9/2010	Hearn et al.	2012/0325227	A1	12/2012	Robinson et al.
2010/0242956	A1	9/2010	Yamada et al.	2012/0325228	A1	12/2012	Williams
2010/0242974	A1	9/2010	Pan	2013/0008457	A1	1/2013	Zheng et al.
2010/0242976	A1	9/2010	Katayama et al.	2013/0014755	A1	1/2013	Kumar et al.
2010/0275938	A1	11/2010	Roth et al.	2013/0014772	A1	1/2013	Liu
2010/0276333	A1	11/2010	Couture	2013/0019887	A1	1/2013	Liu
2010/0307116	A1	12/2010	Fisher	2013/0023850	A1	1/2013	Imran et al.
2010/0307518	A1	12/2010	Wang	2013/0025609	A1	1/2013	Liu
2010/0313901	A1	12/2010	Fernando et al.	2013/0037041	A1	2/2013	Worm et al.
2011/0005535	A1	1/2011	Xiu	2013/0042864	A1	2/2013	Adler et al.
2011/0011396	A1	1/2011	Fang	2013/0042865	A1	2/2013	Monsees et al.
2011/0030706	A1	2/2011	Gibson et al.	2013/0047984	A1	2/2013	Dahne et al.
2011/0036346	A1	2/2011	Cohen et al.	2013/0056012	A1	3/2013	Hearn et al.
2011/0036363	A1	2/2011	Urtsev et al.	2013/0056013	A1	3/2013	Terry et al.
2011/0041861	A1	2/2011	Sebastian et al.	2013/0068239	A1	3/2013	Youn
2011/0049226	A1	3/2011	Moreau et al.	2013/0074857	A1	3/2013	Buchberger
2011/0083684	A1	4/2011	Luan et al.	2013/0081642	A1	4/2013	Safari
2011/0094523	A1	4/2011	Thorens et al.	2013/0087160	A1	4/2013	Gherghe
2011/0097060	A1	4/2011	Michael Buzzetti	2013/0099025	A1	4/2013	McDonnell
2011/0108023	A1	5/2011	McKinney et al.	2013/0140200	A1	6/2013	Scatterday
2011/0120482	A1	5/2011	Brenneise	2013/0146489	A1	6/2013	Scatterday
2011/0126831	A1	6/2011	Fernandez Pernia	2013/0152922	A1	6/2013	Benassayag et al.
2011/0155151	A1	6/2011	Newman et al.	2013/0152954	A1	6/2013	Youn
2011/0155153	A1	6/2011	Thorens et al.	2013/0167854	A1	7/2013	Shin
2011/0162667	A1	7/2011	Burke et al.	2013/0168880	A1	7/2013	Duke
2011/0168194	A1	7/2011	Hon	2013/0174842	A1	7/2013	Young et al.
2011/0180433	A1	7/2011	Rennecamp	2013/0182421	A1	7/2013	Popper et al.
2011/0192397	A1	8/2011	Saskar et al.	2013/0186416	A1	7/2013	Gao et al.
2011/0226236	A1	9/2011	Buchberger	2013/0192615	A1	8/2013	Tucker et al.
2011/0226266	A1	9/2011	Tao	2013/0192618	A1	8/2013	Li et al.
2011/0232654	A1	9/2011	Mass	2013/0192619	A1	8/2013	Tucker et al.
2011/0232655	A1	9/2011	Chan et al.	2013/0199528	A1	8/2013	Goodman et al.
2011/0236002	A1	9/2011	Oglesby et al.	2013/0213417	A1	8/2013	Chong et al.
2011/0240047	A1	10/2011	Adamic	2013/0213418	A1	8/2013	Tucker et al.
2011/0263947	A1	10/2011	Utley et al.	2013/0213419	A1	8/2013	Tucker et al.
2011/0265788	A1	11/2011	Wu	2013/0220315	A1	8/2013	Conley et al.
2011/0265806	A1	11/2011	Alarcon et al.	2013/0220847	A1	8/2013	Fisher et al.
2011/0268809	A1	11/2011	Brinkley et al.	2013/0228190	A1	9/2013	Weiss et al.
2011/0277780	A1	11/2011	Terry et al.	2013/0228191	A1	9/2013	Newton
2011/0278189	A1	11/2011	Terry et al.	2013/0233086	A1	9/2013	Besling et al.
2011/0284520	A1	11/2011	Fong	2013/0247924	A1	9/2013	Scatterday et al.
2011/0290248	A1	12/2011	Schennum	2013/0248385	A1	9/2013	Scatterday et al.
2011/0290269	A1	12/2011	Shimizu	2013/0255702	A1	10/2013	Griffith, Jr. et al.
2011/0293535	A1	12/2011	Kosik et al.	2013/0263869	A1	10/2013	Zhu
2011/0308515	A1	12/2011	Snyder et al.	2013/0276802	A1	10/2013	Scatterday
2011/0308521	A1	12/2011	Kofford	2013/0284190	A1	10/2013	Scatterday et al.
2011/0315152	A1	12/2011	Hearn et al.	2013/0284191	A1	10/2013	Scatterday et al.
2011/0315701	A1	12/2011	Everson	2013/0284192	A1	10/2013	Peleg et al.
2012/0006342	A1	1/2012	Rose et al.	2013/0298905	A1	11/2013	Levin et al.
2012/0060853	A1	3/2012	Robinson et al.	2013/0306065	A1	11/2013	Thorens et al.
2012/0077849	A1	3/2012	Howson et al.	2013/0306084	A1	11/2013	Flick
2012/0086391	A1	4/2012	Smith	2013/0312742	A1	11/2013	Monsees et al.
2012/0111346	A1	5/2012	Rinker et al.	2013/0319431	A1	12/2013	Cyphert et al.
2012/0111347	A1	5/2012	Hon	2013/0319435	A1	12/2013	Flick
2012/0118301	A1	5/2012	Montaser	2013/0319436	A1	12/2013	Liu
2012/0118307	A1	5/2012	Tu	2013/0319437	A1	12/2013	Liu
2012/0125353	A1	5/2012	Wollin	2013/0319439	A1	12/2013	Gorelick et al.
2012/0138052	A1	6/2012	Hearn et al.	2013/0319440	A1	12/2013	Capuano
2012/0174914	A1	7/2012	Pirshafiey et al.	2013/0333700	A1	12/2013	Buchberger
2012/0199146	A1	8/2012	Marangos	2013/0333711	A1	12/2013	Liu
2012/0199572	A1	8/2012	Shen et al.	2013/0336358	A1	12/2013	Liu
2012/0199663	A1	8/2012	Qiu	2013/0340775	A1	12/2013	Juster et al.
2012/0204889	A1	8/2012	Xiu	2013/0342157	A1	12/2013	Liu
2012/0211015	A1	8/2012	Li et al.	2014/0000638	A1	1/2014	Sebastian et al.
2012/0227753	A1	9/2012	Newton	2014/0007891	A1	1/2014	Liu
2012/0234315	A1	9/2012	Li et al.	2014/0007892	A1	1/2014	Liu
2012/0234821	A1	9/2012	Shimizu	2014/0014124	A1	1/2014	Glasberg et al.
2012/0247494	A1	10/2012	Oglesby et al.	2014/0014126	A1	1/2014	Peleg et al.
2012/0255567	A1	10/2012	Rose et al.	2014/0020697	A1	1/2014	Liu
2012/0260926	A1	10/2012	Tu et al.	2014/0034052	A1	2/2014	Glusker et al.
2012/0260927	A1	10/2012	Liu	2014/0034071	A1	2/2014	Levitz et al.
2012/0261286	A1	10/2012	Holloway et al.	2014/0035391	A1	2/2014	Kitani
2012/0267383	A1	10/2012	Van Rooyen	2014/0041655	A1	2/2014	Barron et al.
2012/0279512	A1	11/2012	Hon	2014/0041658	A1	2/2014	Goodman et al.
2012/0285475	A1	11/2012	Liu	2014/0048086	A1	2/2014	Zhanghua
2012/0291791	A1	11/2012	Pradeep	2014/0053856	A1	2/2014	Liu

US D842,536 S

2014/0053858	A1	2/2014	Liu	2014/0261474	A1	9/2014	Gonda
2014/0060528	A1	3/2014	Liu	2014/0261479	A1	9/2014	Xu et al.
2014/0060529	A1	3/2014	Zhang	2014/0261483	A1	9/2014	Hopps
2014/0060552	A1	3/2014	Cohen	2014/0261486	A1	9/2014	Potter et al.
2014/0060556	A1	3/2014	Liu	2014/0261487	A1	9/2014	Chapman et al.
2014/0062417	A1	3/2014	Li et al.	2014/0261488	A1	9/2014	Tucker
2014/0069424	A1	3/2014	Poston et al.	2014/0261489	A1	9/2014	Cadieux et al.
2014/0069425	A1	3/2014	Zhang	2014/0261490	A1	9/2014	Kane
2014/0083442	A1	3/2014	Scatterday	2014/0261491	A1	9/2014	Hawes
2014/0096781	A1	4/2014	Sears et al.	2014/0261492	A1	9/2014	Kane et al.
2014/0096782	A1	4/2014	Ampolini et al.	2014/0261493	A1	9/2014	Smith et al.
2014/0107815	A1	4/2014	LaMothe	2014/0261494	A1	9/2014	Scatterday
2014/0109898	A1	4/2014	Li et al.	2014/0261495	A1	9/2014	Novak, III et al.
2014/0109921	A1	4/2014	Chen	2014/0261497	A1	9/2014	Liu
2014/0116455	A1	5/2014	Youn	2014/0261498	A1	9/2014	Liu
2014/0123989	A1	5/2014	LaMothe	2014/0261500	A1	9/2014	Park
2014/0123990	A1	5/2014	Timmermans	2014/0270727	A1	9/2014	Ampolini et al.
2014/0130796	A1	5/2014	Liu	2014/0270729	A1	9/2014	DePiano et al.
2014/0130797	A1	5/2014	Liu	2014/0270730	A1	9/2014	DePiano et al.
2014/0130816	A1	5/2014	Liu	2014/0271946	A1	9/2014	Kobal et al.
2014/0130817	A1	5/2014	Li et al.	2014/0274940	A1	9/2014	Mishra et al.
2014/0144429	A1	5/2014	Wensley et al.	2014/0276536	A1	9/2014	Estes
2014/0144453	A1	5/2014	Capuano et al.	2014/0278250	A1	9/2014	Smith et al.
2014/0150784	A1	6/2014	Liu	2014/0278258	A1	9/2014	Shafer
2014/0150785	A1	6/2014	Malik et al.	2014/0283823	A1	9/2014	Liu
2014/0150810	A1	6/2014	Hon	2014/0283855	A1	9/2014	Hawes et al.
2014/0158129	A1	6/2014	Pratt, Jr. et al.	2014/0283856	A1	9/2014	Xiang
2014/0161301	A1	6/2014	Merenda	2014/0283857	A1	9/2014	Liu
2014/0166028	A1	6/2014	Fuisz et al.	2014/0283858	A1	9/2014	Liu
2014/0166029	A1	6/2014	Weigensberg et al.	2014/0290673	A1	10/2014	Liu
2014/0166030	A1	6/2014	Li et al.	2014/0290676	A1	10/2014	Liu
2014/0166032	A1	6/2014	Gindrat	2014/0290677	A1	10/2014	Liu
2014/0174458	A1	6/2014	Katz	2014/0299137	A1	10/2014	Kieckbusch et al.
2014/0174459	A1	6/2014	Burstyn	2014/0299138	A1	10/2014	Xiang
2014/0175081	A1	6/2014	Hwa	2014/0299139	A1	10/2014	Liu
2014/0178461	A1	6/2014	Rigas	2014/0299140	A1	10/2014	Liu
2014/0182609	A1	7/2014	Liu	2014/0301721	A1	10/2014	Ruscio et al.
2014/0182610	A1	7/2014	Liu	2014/0305450	A1	10/2014	Xiang
2014/0182611	A1	7/2014	Liu	2014/0305451	A1	10/2014	Liu
2014/0182612	A1	7/2014	Chen	2014/0305452	A1	10/2014	Liu
2014/0190477	A1	7/2014	Qiu	2014/0305454	A1	10/2014	Rinker et al.
2014/0190478	A1	7/2014	Liu	2014/0311503	A1	10/2014	Liu
2014/0190496	A1	7/2014	Wensley et al.	2014/0311504	A1	10/2014	Liu
2014/0190501	A1	7/2014	Liu	2014/0311505	A1	10/2014	Liu
2014/0190502	A1	7/2014	Liu	2014/0321837	A1	10/2014	Flick
2014/0190503	A1	7/2014	Li et al.	2014/0332016	A1	11/2014	Bellinger et al.
2014/0196716	A1	7/2014	Liu	2014/0332017	A1	11/2014	Liu
2014/0196718	A1	7/2014	Li et al.	2014/0332018	A1	11/2014	Liu
2014/0196731	A1	7/2014	Scatterday	2014/0332019	A1	11/2014	Liu
2014/0196733	A1	7/2014	Liu	2014/0332020	A1	11/2014	Li et al.
2014/0196734	A1	7/2014	Liu	2014/0332022	A1	11/2014	Li et al.
2014/0196735	A1	7/2014	Liu	2014/0334803	A1	11/2014	Li et al.
2014/0202474	A1	7/2014	Peleg et al.	2014/0334804	A1	11/2014	Choi
2014/0202475	A1	7/2014	Liu	2014/0338680	A1	11/2014	Abramov et al.
2014/0202477	A1	7/2014	Qi et al.	2014/0338681	A1	11/2014	Liu
2014/0209096	A1	7/2014	Cheyene	2014/0338682	A1	11/2014	Liu
2014/0209106	A1	7/2014	Liu	2014/0338683	A1	11/2014	Liu
2014/0209107	A1	7/2014	Liu	2014/0338684	A1	11/2014	Liu
2014/0209108	A1	7/2014	Li et al.	2014/0338685	A1	11/2014	Amir
2014/0209109	A1	7/2014	Larson	2014/0345631	A1	11/2014	Bowen et al.
2014/0216450	A1	8/2014	Liu	2014/0345632	A1	11/2014	Scatterday
2014/0216483	A1	8/2014	Alima	2014/0345633	A1	11/2014	Talon et al.
2014/0216484	A1	8/2014	Liu	2014/0345635	A1	11/2014	Rabinowitz et al.
2014/0224244	A1	8/2014	Liu	2014/0352177	A1	12/2014	Rehkemper
2014/0224267	A1	8/2014	Levitz et al.	2014/0352705	A1	12/2014	Liu
2014/0230835	A1	8/2014	Saliman	2014/0352707	A1	12/2014	Liu
2014/0238421	A1	8/2014	Shapiro	2014/0353856	A1	12/2014	Dubief
2014/0238422	A1	8/2014	Plunkett et al.	2014/0353867	A1	12/2014	Liu
2014/0238423	A1	8/2014	Tucker et al.	2014/0354215	A1	12/2014	Xiang
2014/0238424	A1	8/2014	Macko et al.	2014/0355969	A1	12/2014	Stern
2014/0246031	A1	9/2014	Liu	2014/0356607	A1	12/2014	Woodcock
2014/0246033	A1	9/2014	Daehne et al.	2014/0360512	A1	12/2014	Xiang
2014/0251324	A1	9/2014	Xiang	2014/0360516	A1	12/2014	Liu
2014/0251325	A1	9/2014	Liu	2014/0366894	A1	12/2014	Liu
2014/0251356	A1	9/2014	Xiang	2014/0366895	A1	12/2014	Li et al.
2014/0253144	A1	9/2014	Novak, III et al.	2014/0366896	A1	12/2014	Li et al.
2014/0254055	A1	9/2014	Xiang	2014/0366897	A1	12/2014	Liu
2014/0259026	A1	9/2014	Xiang	2014/0366898	A1	12/2014	Monsees et al.
2014/0261408	A1	9/2014	DePiano et al.	2014/0366902	A1	12/2014	Chiolini et al.

US D842,536 S

Page 11

2014/0373833	A1	12/2014	Liu	2015/0075545	A1	3/2015	Xiang
2014/0373855	A1	12/2014	Zheng	2015/0075546	A1	3/2015	Kueny, Sr. et al.
2014/0373858	A1	12/2014	Liu	2015/0078735	A1	3/2015	Cormack
2014/0376895	A1	12/2014	Han	2015/0080265	A1	3/2015	Elzinga et al.
2014/0378790	A1	12/2014	Cohen	2015/0082859	A1	3/2015	Xiang
2015/0000682	A1	1/2015	Liu	2015/0083144	A1	3/2015	Xiang
2015/0000683	A1	1/2015	Liu	2015/0083145	A1	3/2015	Li et al.
2015/0007834	A1	1/2015	Liu	2015/0083146	A1	3/2015	Goldman et al.
2015/0007835	A1	1/2015	Liu	2015/0083147	A1	3/2015	Schiff et al.
2015/0007836	A1	1/2015	Li et al.	2015/0090256	A1	4/2015	Chung
2015/0013692	A1	1/2015	Liu	2015/0090277	A1	4/2015	Xiang
2015/0013693	A1	1/2015	Fuisz et al.	2015/0090278	A1	4/2015	Schiff et al.
2015/0013696	A1	1/2015	Plojoux et al.	2015/0090279	A1	4/2015	Chen
2015/0013700	A1	1/2015	Liu	2015/0090280	A1	4/2015	Chen
2015/0013701	A1	1/2015	Liu	2015/0090281	A1	4/2015	Chen
2015/0013702	A1	1/2015	Liu	2015/0100441	A1	4/2015	Alarcon et al.
2015/0015187	A1	1/2015	Xiang	2015/0101606	A1	4/2015	White
2015/0020822	A1	1/2015	Janardhan et al.	2015/0101622	A1	4/2015	Liu
2015/0020823	A1	1/2015	Lipowicz et al.	2015/0101623	A1	4/2015	Liu
2015/0020824	A1	1/2015	Bowen et al.	2015/0101625	A1	4/2015	Newton et al.
2015/0020825	A1	1/2015	Galloway et al.	2015/0101626	A1	4/2015	Li et al.
2015/0020826	A1	1/2015	Liu	2015/0101945	A1	4/2015	Scatterday
2015/0020827	A1	1/2015	Liu	2015/0102777	A1	4/2015	Cooper
2015/0020828	A1	1/2015	Liu	2015/0105455	A1	4/2015	Bjorncrantz
2015/0020829	A1	1/2015	Li	2015/0107609	A1	4/2015	Liu
2015/0020830	A1	1/2015	Koller	2015/0107610	A1	4/2015	Metrangolo et al.
2015/0020831	A1	1/2015	Weigensberg et al.	2015/0107611	A1	4/2015	Metrangolo et al.
2015/0020833	A1	1/2015	Conley et al.	2015/0107612	A1	4/2015	Liu
2015/0027454	A1	1/2015	Li et al.	2015/0108019	A1	4/2015	Liu
2015/0027455	A1	1/2015	Peleg et al.	2015/0114407	A1	4/2015	Duncan et al.
2015/0027456	A1	1/2015	Janardhan et al.	2015/0114410	A1	4/2015	Doster
2015/0027457	A1	1/2015	Janardhan et al.	2015/0114504	A1	4/2015	Cecka et al.
2015/0027460	A1	1/2015	Liu	2015/0117842	A1	4/2015	Brammer et al.
2015/0027461	A1	1/2015	Liu	2015/0122252	A1	5/2015	Frija
2015/0027462	A1	1/2015	Liu	2015/0122274	A1	5/2015	Cohen et al.
2015/0027463	A1	1/2015	Liu	2015/0122278	A1	5/2015	Hardgrove et al.
2015/0027464	A1	1/2015	Liu	2015/0128965	A1	5/2015	Lord
2015/0027465	A1	1/2015	Liu	2015/0128966	A1	5/2015	Lord
2015/0027466	A1	1/2015	Xiang	2015/0128967	A1	5/2015	Robinson et al.
2015/0027467	A1	1/2015	Liu	2015/0128969	A1	5/2015	Chapman et al.
2015/0027468	A1	1/2015	Li et al.	2015/0128970	A1	5/2015	Liu
2015/0027469	A1	1/2015	Tucker et al.	2015/0128971	A1	5/2015	Verleur et al.
2015/0027470	A1	1/2015	Kane et al.	2015/0128972	A1	5/2015	Verleur et al.
2015/0027471	A1	1/2015	Feldman et al.	2015/0128973	A1	5/2015	Li et al.
2015/0027472	A1	1/2015	Amir	2015/0128976	A1	5/2015	Verleur et al.
2015/0027473	A1	1/2015	Graf	2015/0128977	A1	5/2015	Li et al.
2015/0034102	A1	2/2015	Faramarzian	2015/0136153	A1	5/2015	Lord
2015/0034103	A1	2/2015	Hon	2015/0136155	A1	5/2015	Verleur et al.
2015/0034104	A1	2/2015	Zhou	2015/0136156	A1	5/2015	Liu
2015/0034105	A1	2/2015	Liu	2015/0136157	A1	5/2015	Liu
2015/0034106	A1	2/2015	Liu	2015/0136158	A1	5/2015	Stevens et al.
2015/0034107	A1	2/2015	Liu	2015/0142387	A1	5/2015	Alarcon et al.
2015/0034507	A1	2/2015	Liu	2015/0144145	A1	5/2015	Chang et al.
2015/0035540	A1	2/2015	Xiang	2015/0144147	A1	5/2015	Li et al.
2015/0038567	A1	2/2015	Herkenroth et al.	2015/0144148	A1	5/2015	Chen
2015/0040927	A1	2/2015	Li et al.	2015/0150302	A1	6/2015	Metrangolo et al.
2015/0040928	A1	2/2015	Saydar et al.	2015/0150303	A1	6/2015	Jensen
2015/0040929	A1	2/2015	Hon	2015/0150305	A1	6/2015	Shenkal
2015/0041482	A1	2/2015	Liu	2015/0150306	A1	6/2015	Chen
2015/0047658	A1	2/2015	Cyphert et al.	2015/0150307	A1	6/2015	Liu
2015/0047659	A1	2/2015	Liu	2015/0150308	A1	6/2015	Monsees et al.
2015/0047660	A1	2/2015	Liu	2015/0157053	A1	6/2015	Mayor
2015/0047661	A1	2/2015	Blackley et al.	2015/0157054	A1	6/2015	Liu
2015/0047662	A1	2/2015	Hopps	2015/0157055	A1	6/2015	Lord
2015/0047663	A1	2/2015	Liu	2015/0157056	A1	6/2015	Bowen et al.
2015/0053215	A1	2/2015	Liu	2015/0163859	A1	6/2015	Schneider et al.
2015/0053216	A1	2/2015	Liu	2015/0164138	A1	6/2015	Liu
2015/0053217	A1	2/2015	Steingraber et al.	2015/0164141	A1	6/2015	Newton
2015/0053220	A1	2/2015	Levy et al.	2015/0164142	A1	6/2015	Li et al.
2015/0057341	A1	2/2015	Perry	2015/0164143	A1	6/2015	Maas
2015/0059779	A1	3/2015	Alarcon et al.	2015/0164144	A1	6/2015	Liu
2015/0059780	A1	3/2015	Davis et al.	2015/0164145	A1	6/2015	Zhou
2015/0059782	A1	3/2015	Liu	2015/0164146	A1	6/2015	Li et al.
2015/0059783	A1	3/2015	Liu	2015/0164147	A1	6/2015	Verleur et al.
2015/0059784	A1	3/2015	Liu	2015/0167976	A1	6/2015	Recio
2015/0059785	A1	3/2015	Liu	2015/0173124	A1	6/2015	Qiu
2015/0068523	A1	3/2015	Powers et al.	2015/0173417	A1	6/2015	Gennrich et al.
2015/0068543	A1	3/2015	Liu	2015/0173419	A1	6/2015	Tu
2015/0068545	A1	3/2015	Moldoveanu et al.	2015/0173421	A1	6/2015	Hsieh

US D842,536 S

2015/0173422	A1	6/2015	Liu	2015/0272223	A1	10/2015	Weigensberg et al.
2015/0181928	A1	7/2015	Liu	2015/0276262	A1	10/2015	Dai et al.
2015/0181937	A1	7/2015	Dubief et al.	2015/0280273	A1	10/2015	Liu
2015/0181939	A1	7/2015	Liu	2015/0282524	A1	10/2015	Elhalwani
2015/0181940	A1	7/2015	Liu	2015/0282525	A1	10/2015	Plojoux et al.
2015/0181941	A1	7/2015	Liu	2015/0282526	A1	10/2015	Wu
2015/0181943	A1	7/2015	Li et al.	2015/0282527	A1	10/2015	Henry, Jr.
2015/0181944	A1	7/2015	Li et al.	2015/0282529	A1	10/2015	Li et al.
2015/0184846	A1	7/2015	Liu	2015/0282530	A1	10/2015	Johnson et al.
2015/0186837	A1	7/2015	Bianco et al.	2015/0288468	A1	10/2015	Xiang
2015/0189695	A1	7/2015	Xiang	2015/0289565	A1	10/2015	Cadieux et al.
2015/0189915	A1	7/2015	Liu	2015/0289567	A1	10/2015	Liu
2015/0189918	A1	7/2015	Liu	2015/0295921	A1	10/2015	Cao
2015/0189919	A1	7/2015	Liu	2015/0296883	A1	10/2015	Wu
2015/0189920	A1	7/2015	Liu	2015/0296885	A1	10/2015	Liu
2015/0196055	A1	7/2015	Liu	2015/0296886	A1	10/2015	Li et al.
2015/0196056	A1	7/2015	Liu	2015/0296887	A1	10/2015	Zhu
2015/0196057	A1	7/2015	Wu	2015/0296888	A1	10/2015	Liu
2015/0196058	A1	7/2015	Lord	2015/0296889	A1	10/2015	Liu
2015/0196059	A1	7/2015	Liu	2015/0304401	A1	10/2015	Liu
2015/0196060	A1	7/2015	Wensley et al.	2015/0304402	A1	10/2015	Liu
2015/0196062	A1	7/2015	Li et al.	2015/0305403	A1	10/2015	Coelho Belo Fernandes De Carvalho
2015/0200385	A1	7/2015	Liu	2015/0305404	A1	10/2015	Rosales
2015/0201674	A1	7/2015	Dooley et al.	2015/0305406	A1	10/2015	Li et al.
2015/0201675	A1	7/2015	Lord	2015/0305407	A1	10/2015	Li et al.
2015/0201676	A1	7/2015	Shin	2015/0305408	A1	10/2015	Liu
2015/0208724	A1	7/2015	Wu	2015/0305409	A1	10/2015	Verleur et al.
2015/0208725	A1	7/2015	Tsai	2015/0305464	A1	10/2015	Nelson, Jr. et al.
2015/0208726	A1	7/2015	Liu	2015/0313275	A1	11/2015	Anderson et al.
2015/0208728	A1	7/2015	Lord	2015/0313282	A1	11/2015	Ademe et al.
2015/0208729	A1	7/2015	Monsees et al.	2015/0313283	A1	11/2015	Collett et al.
2015/0208730	A1	7/2015	Li et al.	2015/0313284	A1	11/2015	Liu
2015/0208731	A1	7/2015	Malamud et al.	2015/0313285	A1	11/2015	Waller et al.
2015/0216232	A1	8/2015	Bless et al.	2015/0313287	A1	11/2015	Verleur et al.
2015/0216233	A1	8/2015	Sears et al.	2015/0313288	A1	11/2015	Liu
2015/0216234	A1	8/2015	Chung	2015/0313868	A1	11/2015	Morgan
2015/0216235	A1	8/2015	Liu	2015/0320114	A1	11/2015	Wu
2015/0216237	A1	8/2015	Wensley et al.	2015/0320116	A1	11/2015	Bleloch et al.
2015/0217067	A1	8/2015	Hearn et al.	2015/0321804	A1	11/2015	Koller et al.
2015/0217068	A1	8/2015	Wakalopulos	2015/0322451	A1	11/2015	Kudithipudi et al.
2015/0223520	A1	8/2015	Phillips et al.	2015/0327595	A1	11/2015	Scatterday
2015/0223521	A1	8/2015	Menting et al.	2015/0327596	A1	11/2015	Alarcon et al.
2015/0223522	A1	8/2015	Ampolini et al.	2015/0327597	A1	11/2015	Li et al.
2015/0223523	A1	8/2015	McCullough	2015/0327598	A1	11/2015	Xiang
2015/0224268	A1	8/2015	Henry et al.	2015/0328415	A1	11/2015	Minskoff et al.
2015/0227471	A1	8/2015	Stafford et al.	2015/0332379	A1	11/2015	Alarcon
2015/0230521	A1	8/2015	Talon	2015/0333542	A1	11/2015	Alarcon et al.
2015/0237914	A1	8/2015	Han	2015/0333552	A1	11/2015	Alarcon
2015/0237916	A1	8/2015	Farine et al.	2015/0333561	A1	11/2015	Alarcon
2015/0237917	A1	8/2015	Lord	2015/0335071	A1	11/2015	Brinkley et al.
2015/0237918	A1	8/2015	Liu	2015/0335072	A1	11/2015	Giller
2015/0238723	A1	8/2015	Knudsen	2015/0335074	A1	11/2015	Leung
2015/0245654	A1	9/2015	Memari et al.	2015/0335075	A1	11/2015	Minskoff et al.
2015/0245655	A1	9/2015	Memari et al.	2015/0342254	A1	12/2015	Mironov et al.
2015/0245657	A1	9/2015	Memari et al.	2015/0342255	A1	12/2015	Wu
2015/0245658	A1	9/2015	Worm et al.	2015/0342256	A1	12/2015	Chen
2015/0245659	A1	9/2015	DePiano et al.	2015/0342257	A1	12/2015	Chen
2015/0245660	A1	9/2015	Lord	2015/0342258	A1	12/2015	Chen
2015/0245661	A1	9/2015	Milin	2015/0342259	A1	12/2015	Baker et al.
2015/0245665	A1	9/2015	Memari et al.	2015/0351449	A1	12/2015	Righetti
2015/0245666	A1	9/2015	Memari et al.	2015/0351454	A1	12/2015	Huang
2015/0245667	A1	9/2015	Memari et al.	2015/0351455	A1	12/2015	Liu
2015/0245668	A1	9/2015	Memari et al.	2015/0351456	A1	12/2015	Johnson et al.
2015/0245669	A1	9/2015	Cadieux et al.	2015/0351457	A1	12/2015	Liu
2015/0257441	A1	9/2015	Gerkin	2015/0357608	A1	12/2015	Huang
2015/0257444	A1	9/2015	Chung	2015/0357839	A1	12/2015	Cai et al.
2015/0257445	A1	9/2015	Henry, Jr. et al.	2015/0359258	A1	12/2015	Mishra et al.
2015/0257446	A1	9/2015	Chung	2015/0359261	A1	12/2015	Li et al.
2015/0257447	A1	9/2015	Sullivan	2015/0359262	A1	12/2015	Liu et al.
2015/0257449	A1	9/2015	Gabbay	2015/0359263	A1	12/2015	Bellinger
2015/0257451	A1	9/2015	Brannon et al.	2015/0359264	A1	12/2015	Fernando et al.
2015/0258289	A1	9/2015	Henry, Jr. et al.	2015/0359265	A1	12/2015	Liu
2015/0272211	A1	10/2015	Chung	2015/0366250	A1	12/2015	Landau
2015/0272215	A1	10/2015	Esses	2015/0366265	A1	12/2015	Lansing
2015/0272217	A1	10/2015	Chen	2015/0366266	A1	12/2015	Chen
2015/0272218	A1	10/2015	Chen	2015/0366267	A1	12/2015	Liu
2015/0272220	A1	10/2015	Spinka et al.	2015/0366268	A1	12/2015	Shabat
2015/0272221	A1	10/2015	Liu	2015/0374035	A1	12/2015	Sanchez et al.
2015/0272222	A1	10/2015	Spinka et al.				

US D842,536 S

Page 13

2015/0374039	A1	12/2015	Zhu	2016/0120218	A1	5/2016	Schennum et al.
2015/0374040	A1	12/2015	Chen	2016/0120220	A1	5/2016	Malgat et al.
2016/0000147	A1	1/2016	Li et al.	2016/0120222	A1	5/2016	Bagai et al.
2016/0000148	A1	1/2016	Liu	2016/0120223	A1	5/2016	Keen et al.
2016/0000149	A1	1/2016	Scatterday	2016/0120224	A1	5/2016	Mishra et al.
2016/0002649	A1	1/2016	Kudithipudi et al.	2016/0120225	A1	5/2016	Mishra et al.
2016/0007650	A1	1/2016	Duncan et al.	2016/0120226	A1	5/2016	Rado
2016/0007651	A1	1/2016	Ampolini et al.	2016/0120227	A1	5/2016	Levitz et al.
2016/0007653	A1	1/2016	Tu	2016/0120228	A1	5/2016	Rostami et al.
2016/0007654	A1	1/2016	Zhu	2016/0121058	A1	5/2016	Chen
2016/0007655	A1	1/2016	Li et al.	2016/0128384	A1	5/2016	Luciani et al.
2016/0010103	A1	1/2016	Kudithipudi et al.	2016/0128385	A1	5/2016	Lin
2016/0015082	A1	1/2016	Liu	2016/0128387	A1	5/2016	Chen
2016/0018347	A1	1/2016	Drbal et al.	2016/0128388	A1	5/2016	Liu
2016/0020048	A1	1/2016	Ware	2016/0128389	A1	5/2016	Lamb et al.
2016/0021771	A1	1/2016	Zhang et al.	2016/0128390	A1	5/2016	Liu
2016/0021930	A1	1/2016	Minskoff et al.	2016/0129205	A1	5/2016	Shahaf et al.
2016/0021931	A1	1/2016	Hawes et al.	2016/0131629	A1	5/2016	Cadieux, Jr. et al.
2016/0021932	A1	1/2016	Silvestrini et al.	2016/0132898	A1	5/2016	Cadieux et al.
2016/0021933	A1	1/2016	Thorens et al.	2016/0134143	A1	5/2016	Liu
2016/0021934	A1	1/2016	Cadieux et al.	2016/0135494	A1	5/2016	Liu et al.
2016/0029225	A1	1/2016	Hu	2016/0135500	A1	5/2016	Hearn et al.
2016/0029694	A1	2/2016	Clements et al.	2016/0135501	A1	5/2016	Liu
2016/0029697	A1	2/2016	Shafer	2016/0135503	A1	5/2016	Liu
2016/0029698	A1	2/2016	Xiang	2016/0135504	A1	5/2016	Li et al.
2016/0029699	A1	2/2016	Li et al.	2016/0135505	A1	5/2016	Li et al.
2016/0029700	A1	2/2016	Li et al.	2016/0135506	A1	5/2016	Sanchez et al.
2016/0037826	A1	2/2016	Hearn et al.	2016/0135507	A1	5/2016	Thorens et al.
2016/0044961	A1	2/2016	Liu	2016/0136153	A1	5/2016	Jenkins
2016/0044964	A1	2/2016	Liu	2016/0136213	A1	5/2016	Paul
2016/0044965	A1	2/2016	Liu	2016/0138795	A1	5/2016	Meinhart et al.
2016/0044966	A1	2/2016	Li et al.	2016/0143354	A1	5/2016	Liu
2016/0044967	A1	2/2016	Bowen et al.	2016/0143357	A1	5/2016	Liu
2016/0044968	A1	2/2016	Bowen et al.	2016/0143358	A1	5/2016	Zhu
2016/0049682	A1	2/2016	Won et al.	2016/0143359	A1	5/2016	Xiang
2016/0051716	A1	2/2016	Wheelock	2016/0143360	A1	5/2016	Sanchez et al.
2016/0053988	A1	2/2016	Quintana	2016/0143361	A1	5/2016	Juster et al.
2016/0057811	A1	2/2016	Alarcon et al.	2016/0143362	A1	5/2016	Boldrini
2016/0058066	A1	3/2016	Banks et al.	2016/0143363	A1	5/2016	Boldrini
2016/0058071	A1	3/2016	Hearn	2016/0143365	A1	5/2016	Liu
2016/0058072	A1	3/2016	Liu	2016/0144458	A1	5/2016	Boldrini
2016/0058073	A1	3/2016	Chen	2016/0150820	A1	6/2016	Liu
2016/0058074	A1	3/2016	Liu	2016/0150821	A1	6/2016	Liu
2016/0073677	A1	3/2016	Kappel et al.	2016/0150823	A1	6/2016	Liu
2016/0073678	A1	3/2016	Fujisawa et al.	2016/0150824	A1	6/2016	Memari et al.
2016/0073690	A1	3/2016	Liu	2016/0150826	A1	6/2016	Liu
2016/0073691	A1	3/2016	Liu	2016/0150827	A1	6/2016	Liu
2016/0073692	A1	3/2016	Alarcon et al.	2016/0150828	A1	6/2016	Goldstein et al.
2016/0073693	A1	3/2016	Reevell	2016/0150872	A1	6/2016	Zayat
2016/0073694	A1	3/2016	Liu	2016/0157523	A1	6/2016	Liu
2016/0080469	A1	3/2016	Liu	2016/0157524	A1	6/2016	Bowen et al.
2016/0081393	A1	3/2016	Black	2016/0157525	A1	6/2016	Tucker et al.
2016/0081394	A1	3/2016	Alarcon et al.	2016/0158782	A1	6/2016	Henry, Jr. et al.
2016/0081395	A1	3/2016	Thorens et al.	2016/0165952	A1	6/2016	Liu
2016/0088874	A1	3/2016	Lipowicz	2016/0165955	A1	6/2016	Horne
2016/0089508	A1	3/2016	Smith et al.	2016/0166564	A1	6/2016	Myers et al.
2016/0091194	A1	3/2016	Liu	2016/0167846	A1	6/2016	Zahr et al.
2016/0095352	A1	4/2016	Liu	2016/0174076	A1	6/2016	Wu
2016/0095353	A1	4/2016	Liu	2016/0174609	A1	6/2016	Mironov
2016/0095354	A1	4/2016	Wu	2016/0174611	A1	6/2016	Monsees et al.
2016/0095355	A1	4/2016	Hearn	2016/0174613	A1	6/2016	Zuber et al.
2016/0095356	A1	4/2016	Chan	2016/0176564	A1	6/2016	Garthaffner
2016/0095357	A1	4/2016	Burton	2016/0177285	A1	6/2016	Voerman et al.
2016/0099592	A1	4/2016	Gatta et al.	2016/0183592	A1	6/2016	Liu
2016/0100456	A1	4/2016	Tsai	2016/0183593	A1	6/2016	Liu
2016/0100632	A1	4/2016	Debono et al.	2016/0183594	A1	6/2016	Liu
2016/0101909	A1	4/2016	Schennum et al.	2016/0183595	A1	6/2016	Grimandi et al.
2016/0106144	A1	4/2016	Muehlbauer et al.	2016/0183597	A1	6/2016	Li et al.
2016/0106151	A1	4/2016	Swepston et al.	2016/0189216	A1	6/2016	Liu
2016/0106152	A1	4/2016	Liu	2016/0192705	A1	7/2016	Borkovec et al.
2016/0106154	A1	4/2016	Lord	2016/0192706	A1	7/2016	Kananen
2016/0106155	A1	4/2016	Reevell	2016/0192707	A1	7/2016	Li et al.
2016/0106156	A1	4/2016	Qiu	2016/0192708	A1	7/2016	Dermitt et al.
2016/0106936	A1	4/2016	Kimmel	2016/0192709	A1	7/2016	Liu
2016/0109115	A1	4/2016	Lipowicz	2016/0192710	A1	7/2016	Liu
2016/0113323	A1	4/2016	Liu	2016/0198759	A1	7/2016	Kuntawala et al.
2016/0113325	A1	4/2016	Liu	2016/0198763	A1	7/2016	Adkins et al.
2016/0113326	A1	4/2016	Li et al.	2016/0198765	A1	7/2016	Liu
2016/0113327	A1	4/2016	Wu	2016/0198766	A1	7/2016	Liu

US D842,536 S

2016/0198767	A1	7/2016	Verleur	2016/0278163	A1	9/2016	Chen
2016/0198768	A1	7/2016	Liu	2016/0278431	A1	9/2016	Liu
2016/0198769	A1	7/2016	Liu	2016/0278432	A1	9/2016	Liu
2016/0198770	A1	7/2016	Alarcon	2016/0278433	A1	9/2016	Xiang
2016/0200463	A1	7/2016	Hodges et al.	2016/0278434	A1	9/2016	Liu
2016/0201224	A1	7/2016	Xiang	2016/0278435	A1	9/2016	Choukroun et al.
2016/0204637	A1	7/2016	Alarcon et al.	2016/0278436	A1	9/2016	Verleur et al.
2016/0205998	A1	7/2016	Matsumoto et al.	2016/0280450	A1	9/2016	Hearn et al.
2016/0205999	A1	7/2016	Liu	2016/0284197	A1	9/2016	Liu
2016/0206000	A1	7/2016	Lord et al.	2016/0285983	A1	9/2016	Liu
2016/0206002	A1	7/2016	Borkovec et al.	2016/0286856	A1	10/2016	Liu
2016/0206005	A1	7/2016	Yamada et al.	2016/0286858	A1	10/2016	Liu
2016/0206006	A1	7/2016	Li et al.	2016/0286859	A1	10/2016	Liu
2016/0211693	A1	7/2016	Stevens et al.	2016/0286860	A1	10/2016	Flayler
2016/0212520	A1	7/2016	Merenda	2016/0286862	A1	10/2016	Silvettrini
2016/0213060	A1	7/2016	Thaler	2016/0286863	A1	10/2016	Lin
2016/0213061	A1	7/2016	Liu	2016/0286864	A1	10/2016	Lin
2016/0213062	A1	7/2016	Doyle	2016/0286865	A1	10/2016	King et al.
2016/0213065	A1	7/2016	Wensley et al.	2016/0295913	A1	10/2016	Guo et al.
2016/0213066	A1	7/2016	Zitzke et al.	2016/0295915	A1	10/2016	Jochnowitz et al.
2016/0213067	A1	7/2016	Hon	2016/0295916	A1	10/2016	Malgat et al.
2016/0213866	A1	7/2016	Tan	2016/0295917	A1	10/2016	Malgat et al.
2016/0219932	A1	8/2016	Glaser	2016/0295918	A1	10/2016	Liu
2016/0219933	A1	8/2016	Henry, Jr. et al.	2016/0295920	A1	10/2016	Liu
2016/0219934	A1	8/2016	Li et al.	2016/0295922	A1	10/2016	John et al.
2016/0219936	A1	8/2016	Alarcon	2016/0295923	A1	10/2016	Lin
2016/0219937	A1	8/2016	Rado	2016/0295924	A1	10/2016	Liu
2016/0219938	A1	8/2016	Mamoun et al.	2016/0295925	A1	10/2016	Chen
2016/0221707	A1	8/2016	Xu et al.	2016/0295926	A1	10/2016	Zuber
2016/0226286	A1	8/2016	Xiang	2016/0297341	A1	10/2016	Wallace et al.
2016/0227837	A1	8/2016	Hammel et al.	2016/0302471	A1	10/2016	Bowen et al.
2016/0227838	A1	8/2016	Johnson et al.	2016/0302483	A1	10/2016	Liu
2016/0227839	A1	8/2016	Zuber et al.	2016/0302484	A1	10/2016	Gupta et al.
2016/0227840	A1	8/2016	Xiang	2016/0302485	A1	10/2016	Alima
2016/0227841	A1	8/2016	Li et al.	2016/0302486	A1	10/2016	Eroch
2016/0227842	A1	8/2016	Xiang	2016/0302487	A1	10/2016	Chen
2016/0233705	A1	8/2016	Liu	2016/0302488	A1	10/2016	Fernando et al.
2016/0233708	A1	8/2016	Liu	2016/0309775	A1	10/2016	Parker
2016/0235119	A1	8/2016	Liu	2016/0309779	A1	10/2016	Liu
2016/0235120	A1	8/2016	Liu	2016/0309780	A1	10/2016	Chen et al.
2016/0235121	A1	8/2016	Rogan et al.	2016/0309781	A1	10/2016	Malgat et al.
2016/0235124	A1	8/2016	Krietzman	2016/0309783	A1	10/2016	Hopps et al.
2016/0235125	A1	8/2016	Safari	2016/0309784	A1	10/2016	Silvestrini et al.
2016/0242463	A1	8/2016	Liu	2016/0309785	A1	10/2016	Holtz
2016/0242464	A1	8/2016	Liu	2016/0309786	A1	10/2016	Holtz et al.
2016/0242465	A1	8/2016	Zheng et al.	2016/0309789	A1	10/2016	Thomas, Jr.
2016/0242466	A1	8/2016	Lord et al.	2016/0315488	A1	10/2016	Moon
2016/0242467	A1	8/2016	Vaughn	2016/0316818	A1	11/2016	Liu
2016/0242468	A1	8/2016	Liu	2016/0316820	A1	11/2016	Liu
2016/0249680	A1	9/2016	Liu	2016/0316821	A1	11/2016	Liu
2016/0249682	A1	9/2016	Leadley et al.	2016/0316822	A1	11/2016	Liu
2016/0249683	A1	9/2016	Li et al.	2016/0321879	A1	11/2016	Oh et al.
2016/0249684	A1	9/2016	Liu	2016/0323404	A1	11/2016	Liu
2016/0255876	A1	9/2016	Rostami	2016/0324211	A1	11/2016	Yankelevich
2016/0255878	A1	9/2016	Huang et al.	2016/0324213	A1	11/2016	Liu
2016/0260156	A1	9/2016	Liu	2016/0324215	A1	11/2016	Mironov et al.
2016/0261021	A1	9/2016	Marion et al.	2016/0324217	A1	11/2016	Cameron
2016/0262443	A1	9/2016	Piccirilli et al.	2016/0324218	A1	11/2016	Wang et al.
2016/0262445	A1	9/2016	Benjak et al.	2016/0324219	A1	11/2016	Li et al.
2016/0262449	A1	9/2016	Liu	2016/0325055	A1	11/2016	Cameron
2016/0262450	A1	9/2016	Liu	2016/0325858	A1	11/2016	Ampolini et al.
2016/0262451	A1	9/2016	Liu	2016/0331022	A1	11/2016	Cameron
2016/0262452	A1	9/2016	Zhu	2016/0331023	A1	11/2016	Cameron
2016/0262453	A1	9/2016	Ampolini et al.	2016/0331024	A1	11/2016	Cameron
2016/0262454	A1	9/2016	Sears et al.	2016/0331025	A1	11/2016	Cameron
2016/0262455	A1	9/2016	Chen	2016/0331026	A1	11/2016	Cameron
2016/0262456	A1	9/2016	Borkovec et al.	2016/0331027	A1	11/2016	Cameron
2016/0262457	A1	9/2016	Borkovec et al.	2016/0331028	A1	11/2016	Xu
2016/0262459	A1	9/2016	Monsees et al.	2016/0331029	A1	11/2016	Contreras
2016/0262526	A1	9/2016	Gonzalez	2016/0331030	A1	11/2016	Ampolini et al.
2016/0268824	A1	9/2016	Liu	2016/0331032	A1	11/2016	Malgat et al.
2016/0270441	A1	9/2016	Lewis et al.	2016/0331033	A1	11/2016	Hopps et al.
2016/0270442	A1	9/2016	Liu	2016/0331034	A1	11/2016	Cameron
2016/0270443	A1	9/2016	Liu	2016/0331035	A1	11/2016	Cameron
2016/0270444	A1	9/2016	Lin	2016/0331037	A1	11/2016	Cameron
2016/0270445	A1	9/2016	Liu	2016/0331038	A1	11/2016	Farine et al.
2016/0270446	A1	9/2016	Shenkal et al.	2016/0331039	A1	11/2016	Thorens et al.
2016/0270447	A1	9/2016	Borkovec	2016/0331040	A1	11/2016	Nakano et al.
2016/0271347	A1	9/2016	Raichman	2016/0332754	A1	11/2016	Brown et al.

US D842,536 S

Page 15

2016/0334847	A1	11/2016	Cameron	2017/0006917	A1	1/2017	Alvarez
2016/0337141	A1	11/2016	Cameron	2017/0006918	A1	1/2017	Chen et al.
2016/0337362	A1	11/2016	Cameron	2017/0006919	A1	1/2017	Liu
2016/0337444	A1	11/2016	Cameron	2017/0006920	A1	1/2017	Liu
2016/0338402	A1	11/2016	Buehler et al.	2017/0006921	A1	1/2017	Lemay et al.
2016/0338405	A1	11/2016	Liu	2017/0006922	A1	1/2017	Wang et al.
2016/0338406	A1	11/2016	Liu	2017/0013875	A1	1/2017	Schennum et al.
2016/0338407	A1	11/2016	Kerdelmelidis	2017/0013876	A1	1/2017	Schennum et al.
2016/0338408	A1	11/2016	Guenther, Jr. et al.	2017/0013878	A1	1/2017	Schuler et al.
2016/0338409	A1	11/2016	Varone	2017/0013880	A1	1/2017	O'Brien et al.
2016/0338410	A1	11/2016	Batista et al.	2017/0013881	A1	1/2017	Liu
2016/0338411	A1	11/2016	Liu	2017/0013882	A1	1/2017	Liu
2016/0338412	A1	11/2016	Monsees et al.	2017/0013883	A1	1/2017	Han et al.
2016/0338413	A1	11/2016	Li et al.	2017/0013885	A1	1/2017	Qiu
2016/0338945	A1	11/2016	Knight	2017/0014582	A1	1/2017	Skoda
2016/0345621	A1	12/2016	Li et al.	2017/0018000	A1	1/2017	Cameron
2016/0345625	A1	12/2016	Liu	2017/0019951	A1	1/2017	Louveau et al.
2016/0345626	A1	12/2016	Wong et al.	2017/0020188	A1	1/2017	Cameron
2016/0345627	A1	12/2016	Liu	2017/0020191	A1	1/2017	Lamb et al.
2016/0345628	A1	12/2016	Sabet	2017/0020193	A1	1/2017	Davis et al.
2016/0345630	A1	12/2016	Mironov et al.	2017/0020194	A1	1/2017	Rehders
2016/0345631	A1	12/2016	Monsees et al.	2017/0020195	A1	1/2017	Cameron
2016/0345632	A1	12/2016	Lipowicz	2017/0020196	A1	1/2017	Cameron
2016/0345633	A1	12/2016	DePiano et al.	2017/0020197	A1	1/2017	Cameron
2016/0345634	A1	12/2016	Fernando et al.	2017/0020198	A1	1/2017	Naqwi et al.
2016/0345636	A1	12/2016	Liu	2017/0020201	A1	1/2017	Xiang
2016/0351044	A1	12/2016	Liu	2017/0020791	A1	1/2017	Moszner et al.
2016/0353798	A1	12/2016	Liu	2017/0021969	A1	1/2017	Smith et al.
2016/0353800	A1	12/2016	Di Carlo	2017/0023952	A1	1/2017	Henry, Jr. et al.
2016/0353805	A1	12/2016	Hawes et al.	2017/0027221	A1	2/2017	Liu
2016/0356751	A1	12/2016	Blackley	2017/0027223	A1	2/2017	Eksouzian
2016/0360784	A1	12/2016	Liu	2017/0027224	A1	2/2017	Volodarsky
2016/0360785	A1	12/2016	Bless et al.	2017/0027227	A1	2/2017	Lipowicz
2016/0360786	A1	12/2016	Bellinger et al.	2017/0027228	A1	2/2017	Rastogi
2016/0360787	A1	12/2016	Bailey	2017/0027229	A1	2/2017	Cameron
2016/0360788	A1	12/2016	Wang	2017/0027230	A1	2/2017	Fornarelli
2016/0360789	A1	12/2016	Hawes et al.	2017/0027231	A1	2/2017	Xiang
2016/0360790	A1	12/2016	Calfee et al.	2017/0027232	A1	2/2017	Scheck et al.
2016/0360792	A1	12/2016	Liu	2017/0027233	A1	2/2017	Mironov
2016/0360793	A1	12/2016	Liu	2017/0027234	A1	2/2017	Farine et al.
2016/0363570	A1	12/2016	Blackley	2017/0033568	A1	2/2017	Holzherr
2016/0363917	A1	12/2016	Blackley	2017/0033836	A1	2/2017	Bernauer et al.
2016/0366725	A1	12/2016	Tucker et al.	2017/0035101	A1	2/2017	Balder
2016/0366927	A1	12/2016	Liu	2017/0035109	A1	2/2017	Liu
2016/0366928	A1	12/2016	Liu	2017/0035110	A1	2/2017	Keen
2016/0366933	A1	12/2016	Liu	2017/0035111	A1	2/2017	Slurink et al.
2016/0366935	A1	12/2016	Liu	2017/0035112	A1	2/2017	Thorens
2016/0366936	A1	12/2016	Liu	2017/0035113	A1	2/2017	Thorens
2016/0366937	A1	12/2016	Liu	2017/0035114	A1	2/2017	Lord
2016/0366938	A1	12/2016	Wu	2017/0035115	A1	2/2017	Monsees et al.
2016/0366939	A1	12/2016	Alarcon et al.	2017/0035117	A1	2/2017	Lin
2016/0366940	A1	12/2016	Liu	2017/0035118	A1	2/2017	Liu
2016/0366941	A1	12/2016	Lin	2017/0035119	A1	2/2017	Otto
2016/0366942	A1	12/2016	Liu	2017/0041646	A1	2/2017	Pizzurro et al.
2016/0366943	A1	12/2016	Li et al.	2017/0042225	A1	2/2017	Liu
2016/0366945	A1	12/2016	Rado	2017/0042227	A1	2/2017	Gavriellov et al.
2016/0366947	A1	12/2016	Monsees et al.	2017/0042228	A1	2/2017	Liu
2016/0367925	A1	12/2016	Blackley	2017/0042229	A1	2/2017	Liu
2016/0368670	A1	12/2016	Beardsall	2017/0042230	A1	2/2017	Cameron
2016/0368677	A1	12/2016	Parsons et al.	2017/0042231	A1	2/2017	Cameron
2016/0370335	A1	12/2016	Blackley	2017/0042242	A1	2/2017	Hon
2016/0371437	A1	12/2016	Alarcon et al.	2017/0042243	A1	2/2017	Plojoux et al.
2016/0371464	A1	12/2016	Bricker	2017/0042245	A1	2/2017	Buchberger et al.
2016/0374390	A1	12/2016	Liu	2017/0042246	A1	2/2017	Lau et al.
2016/0374391	A1	12/2016	Liu	2017/0042247	A1	2/2017	Xiang
2016/0374392	A1	12/2016	Liu	2017/0042248	A1	2/2017	Xiang
2016/0374393	A1	12/2016	Chen	2017/0042250	A1	2/2017	Takeuchi et al.
2016/0374394	A1	12/2016	Hawes et al.	2017/0046357	A1	2/2017	Cameron
2016/0374395	A1	12/2016	Jordan et al.	2017/0046722	A1	2/2017	Ertugrul
2016/0374396	A1	12/2016	Jordan et al.	2017/0046738	A1	2/2017	Cameron
2016/0374397	A1	12/2016	Jordan et al.	2017/0047756	A1	2/2017	Xiang
2016/0374398	A1	12/2016	Amir	2017/0048691	A1	2/2017	Liu
2016/0374399	A1	12/2016	Monsees et al.	2017/0049149	A1	2/2017	Carty
2016/0374400	A1	12/2016	Monsees et al.	2017/0049150	A1	2/2017	Xue et al.
2016/0374401	A1	12/2016	Liu	2017/0049151	A1	2/2017	Xue et al.
2017/0000190	A1	1/2017	Wu	2017/0049152	A1	2/2017	Liu
2017/0000192	A1	1/2017	Li	2017/0049153	A1	2/2017	Guo et al.
2017/0006915	A1	1/2017	Li et al.	2017/0049154	A1	2/2017	Batista
2017/0006916	A1	1/2017	Liu	2017/0049155	A1	2/2017	Liu

US D842,536 S

2017/0049156	A1	2/2017	Wang et al.	2017/0112192	A1	4/2017	Shan
2017/0050798	A1	2/2017	Ludewig et al.	2017/0112193	A1	4/2017	Chen
2017/0055577	A1	3/2017	Batista	2017/0112196	A1	4/2017	Sur et al.
2017/0055579	A1	3/2017	Kuna et al.	2017/0112197	A1	4/2017	Li et al.
2017/0055586	A1	3/2017	Liu	2017/0113819	A1	4/2017	Marz
2017/0055588	A1	3/2017	Cameron	2017/0117654	A1	4/2017	Cruz
2017/0055589	A1	3/2017	Fernando et al.	2017/0118292	A1	4/2017	Xiang
2017/0064994	A1	3/2017	Xu et al.	2017/0118584	A1	4/2017	Xiang
2017/0064999	A1	3/2017	Perez et al.	2017/0119040	A1	5/2017	Cameron
2017/0065000	A1	3/2017	Sears et al.	2017/0119044	A1*	5/2017	Oligschlaeger A24F 15/00
2017/0065001	A1	3/2017	Li et al.	2017/0119050	A1	5/2017	Blandino et al.
2017/0066556	A1	3/2017	Liu	2017/0119052	A1	5/2017	Williams et al.
2017/0071249	A1	3/2017	Ampolini et al.	2017/0119053	A1	5/2017	Henry, Jr. et al.
2017/0071251	A1	3/2017	Goch	2017/0119054	A1	5/2017	Zinovik et al.
2017/0071252	A1	3/2017	Liu	2017/0119055	A1	5/2017	Liu
2017/0071256	A1	3/2017	Verleur et al.	2017/0119057	A1	5/2017	Liu
2017/0071257	A1	3/2017	Lin	2017/0119058	A1	5/2017	Cameron
2017/0071258	A1	3/2017	Li et al.	2017/0119060	A1	5/2017	Li et al.
2017/0071260	A1	3/2017	Li et al.	2017/0119061	A1	5/2017	Li et al.
2017/0071262	A1	3/2017	Liu	2017/0127722	A1	5/2017	Davis et al.
2017/0079110	A1	3/2017	Plattner	2017/0127723	A1	5/2017	Wu
2017/0079319	A1	3/2017	Muhammed et al.	2017/0127724	A1	5/2017	Liu
2017/0079321	A1	3/2017	Golz	2017/0127725	A1	5/2017	Buchberger et al.
2017/0079322	A1	3/2017	Li et al.	2017/0127726	A1	5/2017	Xiang
2017/0079323	A1	3/2017	Wang	2017/0127728	A1	5/2017	Li et al.
2017/0079324	A1	3/2017	Eksouzian	2017/0129661	A1	5/2017	Van Tassell, III et al.
2017/0079327	A1	3/2017	Wu et al.	2017/0135397	A1	5/2017	Buehler et al.
2017/0079328	A1	3/2017	Wu	2017/0135398	A1	5/2017	Scott et al.
2017/0079329	A1	3/2017	Zitzke	2017/0135399	A1	5/2017	Gavriellov et al.
2017/0079330	A1	3/2017	Mironov et al.	2017/0135400	A1	5/2017	Liu
2017/0079331	A1	3/2017	Monsees et al.	2017/0135401	A1	5/2017	Dickens
2017/0079332	A1	3/2017	Li et al.	2017/0135402	A1	5/2017	Zitzke
2017/0086496	A1	3/2017	Cameron	2017/0135403	A1	5/2017	Liu
2017/0086497	A1	3/2017	Cameron	2017/0135407	A1	5/2017	Cameron
2017/0086498	A1	3/2017	Daryani	2017/0135408	A1	5/2017	Cameron
2017/0086499	A1	3/2017	Mize	2017/0135409	A1	5/2017	Cameron
2017/0086500	A1	3/2017	Li et al.	2017/0135410	A1	5/2017	Cameron
2017/0086501	A1	3/2017	Buehler et al.	2017/0135411	A1	5/2017	Cameron
2017/0086502	A1	3/2017	Hearn et al.	2017/0135412	A1	5/2017	Cameron
2017/0086503	A1	3/2017	Cameron	2017/0136193	A1	5/2017	Cameron
2017/0086504	A1	3/2017	Cameron	2017/0136194	A1	5/2017	Cameron
2017/0086505	A1	3/2017	Cameron	2017/0136301	A1	5/2017	Cameron
2017/0086506	A1	3/2017	Rado	2017/0143035	A1	5/2017	Pucci
2017/0086507	A1	3/2017	Rado	2017/0143037	A9	5/2017	Larson
2017/0086508	A1	3/2017	Mironov et al.	2017/0143038	A1	5/2017	Dickens
2017/0091490	A1	3/2017	Cameron	2017/0143040	A1	5/2017	Liu
2017/0091853	A1	3/2017	Cameron	2017/0143043	A1	5/2017	Liu
2017/0092106	A1	3/2017	Cameron	2017/0143917	A1	5/2017	Cohen et al.
2017/0092900	A1	3/2017	Yang	2017/0144827	A1	5/2017	Batista
2017/0093960	A1	3/2017	Cameron	2017/0146005	A1	5/2017	Edelen
2017/0093981	A1	3/2017	Cameron	2017/0150753	A1	6/2017	Macko
2017/0094998	A1	4/2017	Bernauer et al.	2017/0150754	A1	6/2017	Lin
2017/0094999	A1	4/2017	Hearn et al.	2017/0150755	A1	6/2017	Batista
2017/0095000	A1	4/2017	Spirito et al.	2017/0150756	A1	6/2017	Rexroad et al.
2017/0095001	A1	4/2017	Liu	2017/0150758	A1	6/2017	Fernando et al.
2017/0095002	A1	4/2017	Silvestrini	2017/0156397	A1	6/2017	Sur et al.
2017/0095003	A1	4/2017	Mironov	2017/0156398	A1	6/2017	Sur et al.
2017/0095004	A1	4/2017	Liu	2017/0156400	A1	6/2017	Liu
2017/0095005	A1	4/2017	Monsees et al.	2017/0156401	A1	6/2017	Liu
2017/0095518	A1	4/2017	Bjorncrantz	2017/0156402	A1	6/2017	Liu
2017/0095623	A1	4/2017	Trzeciecki	2017/0156403	A1	6/2017	Gill et al.
2017/0099877	A1	4/2017	Worm et al.	2017/0156404	A1	6/2017	Novak, III et al.
2017/0099879	A1	4/2017	Heidl	2017/0156408	A1	6/2017	Li et al.
2017/0099880	A1	4/2017	Hawes	2017/0158436	A1	6/2017	Slurink
2017/0101256	A1	4/2017	Zeitlin et al.	2017/0162523	A1	6/2017	Hu
2017/0102013	A1	4/2017	Wallman et al.	2017/0162979	A1	6/2017	Liu
2017/0105448	A1	4/2017	Scarpulla	2017/0164655	A1	6/2017	Chen
2017/0105449	A1	4/2017	Hearn et al.	2017/0164656	A1	6/2017	Eusepi et al.
2017/0105450	A1	4/2017	Reed et al.	2017/0164657	A1	6/2017	Batista
2017/0105451	A1	4/2017	Fornarelli	2017/0164658	A1	6/2017	Lin et al.
2017/0105452	A1	4/2017	Mironov et al.	2017/0170439	A1	6/2017	Jarvis et al.
2017/0105453	A1	4/2017	Li et al.	2017/0172204	A1	6/2017	Kane et al.
2017/0105454	A1	4/2017	Li et al.	2017/0172205	A1	6/2017	Chang et al.
2017/0105455	A1	4/2017	Qiu	2017/0172207	A1	6/2017	Liu
2017/0108210	A1	4/2017	Meinhart et al.	2017/0172208	A1	6/2017	Mironov
2017/0108840	A1	4/2017	Hawes et al.	2017/0172209	A1	6/2017	Saydar et al.
2017/0109877	A1	4/2017	Peleg et al.	2017/0172213	A1	6/2017	Hon
2017/0112182	A1	4/2017	Arnold	2017/0172214	A1	6/2017	Li et al.
2017/0112190	A1	4/2017	Buchberger	2017/0172215	A1	6/2017	Li et al.

US D842,536 S

2017/0181223	A1	6/2017	Sur et al.	2017/0231273	A1	8/2017	Xiang
2017/0181467	A1	6/2017	Cameron	2017/0231275	A1	8/2017	Guenther
2017/0181468	A1	6/2017	Bowen et al.	2017/0231276	A1	8/2017	Mironov et al.
2017/0181470	A1	6/2017	Li	2017/0231277	A1	8/2017	Mironov et al.
2017/0181471	A1	6/2017	Phillips et al.	2017/0231278	A1	8/2017	Mironov et al.
2017/0181473	A1	6/2017	Batista et al.	2017/0231279	A1	8/2017	Watson
2017/0181474	A1	6/2017	Cameron	2017/0231280	A1	8/2017	Anton
2017/0181475	A1	6/2017	Cameron	2017/0231281	A1	8/2017	Hatton et al.
2017/0181476	A1	6/2017	Li et al.	2017/0231282	A1	8/2017	Bowen et al.
2017/0181928	A1	6/2017	Collins et al.	2017/0231283	A1	8/2017	Gadas
2017/0185364	A1	6/2017	Cameron	2017/0231284	A1	8/2017	Newns
2017/0186122	A1	6/2017	Levings et al.	2017/0231285	A1	8/2017	Holzherr et al.
2017/0188626	A1	7/2017	Davis et al.	2017/0231286	A1	8/2017	Borkovec et al.
2017/0188627	A1	7/2017	Sur	2017/0233114	A1	8/2017	Christensen et al.
2017/0188628	A1	7/2017	Montgomery	2017/0238596	A1	8/2017	Matsumoto et al.
2017/0188629	A1	7/2017	Dickens et al.	2017/0238605	A1	8/2017	Matsumoto et al.
2017/0188631	A1	7/2017	Lin	2017/0238606	A1	8/2017	Matsumoto et al.
2017/0188632	A1	7/2017	Hon	2017/0238608	A1	8/2017	Matsumoto et al.
2017/0188634	A1	7/2017	Plojoux et al.	2017/0238609	A1	8/2017	Schlipf
2017/0188635	A1	7/2017	Force et al.	2017/0238611	A1	8/2017	Buchberger
2017/0188636	A1	7/2017	Li et al.	2017/0238612	A1	8/2017	Daryani et al.
2017/0196263	A1	7/2017	Sur	2017/0238613	A1	8/2017	Suess et al.
2017/0196264	A1	7/2017	Liu	2017/0238614	A1	8/2017	Li et al.
2017/0196265	A1	7/2017	Liu	2017/0238617	A1	8/2017	Scatterday
2017/0196267	A1	7/2017	Zou et al.	2017/0241857	A1	8/2017	Hearn et al.
2017/0196268	A1	7/2017	Reevell	2017/0245543	A1	8/2017	Karles et al.
2017/0196269	A1	7/2017	Bernauer et al.	2017/0245546	A1	8/2017	Huang
2017/0196270	A1	7/2017	Vick et al.	2017/0245547	A1	8/2017	Lipowicz
2017/0196271	A1	7/2017	Levitz et al.	2017/0245550	A1	8/2017	Freelander
2017/0196272	A1	7/2017	Li et al.	2017/0245551	A1	8/2017	Reevell
2017/0196273	A1	7/2017	Qiu	2017/0245554	A1	8/2017	Perez et al.
2017/0202265	A1	7/2017	Hawes et al.	2017/0246399	A1	8/2017	Forlani et al.
2017/0202266	A1	7/2017	Sur	2017/0246405	A1	8/2017	Wensley et al.
2017/0202267	A1	7/2017	Liu	2017/0246407	A1	8/2017	Matsumoto et al.
2017/0202268	A1	7/2017	Li et al.	2017/0250552	A1	8/2017	Liu
2017/0207499	A1	7/2017	Leadley	2017/0251714	A1	9/2017	Mishra et al.
2017/0208857	A1	7/2017	Branton et al.	2017/0251718	A1	9/2017	Armoush et al.
2017/0208858	A1	7/2017	Li	2017/0251719	A1	9/2017	Cyphert et al.
2017/0208862	A1	7/2017	Li et al.	2017/0251721	A1	9/2017	Rostami et al.
2017/0208863	A1	7/2017	Davis et al.	2017/0251722	A1	9/2017	Kobal et al.
2017/0208864	A1	7/2017	Anderson, Jr. et al.	2017/0251723	A1	9/2017	Kobal et al.
2017/0208865	A1	7/2017	Nettenstrom et al.	2017/0251724	A1	9/2017	Lamb et al.
2017/0208866	A1	7/2017	Liu	2017/0251725	A1	9/2017	Buchberger et al.
2017/0208867	A1	7/2017	Li et al.	2017/0251726	A1	9/2017	Nielsen
2017/0208868	A1	7/2017	Li et al.	2017/0251727	A1	9/2017	Nielsen
2017/0208869	A1	7/2017	Li et al.	2017/0251728	A1	9/2017	Peleg et al.
2017/0208870	A1	7/2017	Liu	2017/0251729	A1	9/2017	Li et al.
2017/0208882	A1	7/2017	Lambertz	2017/0258129	A1	9/2017	Haun
2017/0214261	A1	7/2017	Gratton	2017/0258132	A1	9/2017	Rostami et al.
2017/0215470	A1	8/2017	Piccirilli et al.	2017/0258134	A1	9/2017	Kane
2017/0215473	A1	8/2017	Nakano et al.	2017/0258137	A1	9/2017	Smith et al.
2017/0215474	A1	8/2017	Li	2017/0258138	A1	9/2017	Rostami et al.
2017/0215476	A1	8/2017	Dickens et al.	2017/0258139	A1	9/2017	Rostami et al.
2017/0215477	A1	8/2017	Reevell	2017/0258140	A1	9/2017	Rostami et al.
2017/0215478	A1	8/2017	Harrison et al.	2017/0258142	A1	9/2017	Hatton et al.
2017/0215479	A1	8/2017	Kies	2017/0258143	A1	9/2017	Lederer
2017/0215480	A1	8/2017	Qiu	2017/0259170	A1	9/2017	Bowen et al.
2017/0215481	A1	8/2017	Li et al.	2017/0259954	A1	9/2017	Schwester
2017/0215482	A1	8/2017	Levitz et al.	2017/0261200	A1	9/2017	Stultz
2017/0215483	A1	8/2017	Li et al.	2017/0265517	A1	9/2017	Swede et al.
2017/0215484	A1	8/2017	Xiang	2017/0265522	A1	9/2017	Li et al.
2017/0215485	A1	8/2017	Zitzke	2017/0265524	A1	9/2017	Cadieux et al.
2017/0217607	A1	8/2017	Slurink	2017/0265525	A1	9/2017	Li et al.
2017/0219199	A1	8/2017	Lou et al.	2017/0266397	A1	9/2017	Mayle et al.
2017/0219391	A1	8/2017	Lin et al.	2017/0273353	A1	9/2017	Gindrat
2017/0222468	A1	8/2017	Schennum et al.	2017/0273354	A1	9/2017	Tucker et al.
2017/0224013	A1	8/2017	Huang	2017/0273355	A1	9/2017	Rogers et al.
2017/0224014	A1	8/2017	Fraser	2017/0273357	A1	9/2017	Barbuck
2017/0224016	A1	8/2017	Reevell	2017/0273358	A1	9/2017	Batista et al.
2017/0224017	A1	8/2017	Li et al.	2017/0273359	A1	9/2017	Liu
2017/0224018	A1	8/2017	Li et al.	2017/0273360	A1	9/2017	Brinkley et al.
2017/0224022	A1	8/2017	Liu	2017/0273361	A1	9/2017	Li et al.
2017/0224023	A1	8/2017	Lin et al.	2017/0273914	A1	9/2017	Knudsen
2017/0224024	A1	8/2017	Jochnowitz et al.	2017/0280767	A1	10/2017	Li et al.
2017/0229885	A1	8/2017	Bernauer	2017/0280768	A1	10/2017	Lipowicz
2017/0229888	A1	8/2017	Liu	2017/0280769	A1	10/2017	Li et al.
2017/0231266	A1	8/2017	Mishra et al.	2017/0280770	A1	10/2017	Wang et al.
2017/0231267	A1	8/2017	Shi et al.	2017/0280771	A1	10/2017	Courbat et al.
2017/0231269	A1	8/2017	Besso et al.	2017/0280775	A1	10/2017	Manca et al.

2017/0280776	A1	10/2017	Manca et al.	EP	0532194	A1	3/1993
2017/0280778	A1	10/2017	Force	EP	0535695	A2	4/1993
2017/0281883	A1	10/2017	Li et al.	EP	0762258	A2	3/1997
2017/0283154	A1	10/2017	Karles et al.	EP	2110033	A1	10/2009
2017/0285810	A1	10/2017	Krah	EP	2186507	A2	5/2010
2017/0290368	A1	10/2017	Hearn	EP	2399636	A1	12/2011
2017/0290369	A1	10/2017	Norasak	EP	2573900	A1	3/2013
2017/0290370	A1	10/2017	Garthaffner et al.	EP	2614731	A1	7/2013
2017/0290371	A1	10/2017	Davis et al.	EP	2711006	A1	3/2014
2017/0290373	A1	10/2017	Hon	EP	2641669	B1	5/2014
2017/0290998	A1	10/2017	Poston et al.	EP	2789248	A1	10/2014
2017/0295840	A1	10/2017	Rath et al.	EP	2493342	B1	12/2014
2017/0295843	A1	10/2017	Storch	EP	2856893	A1	4/2015
2017/0295844	A1	10/2017	Thevenaz et al.	EP	2862454	A1	4/2015
2017/0295845	A1	10/2017	Bajpai et al.	EP	2862457	A1	4/2015
2017/0295846	A1	10/2017	Liu	EP	2944206	A1	11/2015
2017/0295847	A1	10/2017	Liu	EP	2952110	A1	12/2015
2017/0295848	A1	10/2017	LaMothe	EP	2989912	A1	3/2016
2017/0295849	A1	10/2017	Cadieux et al.	EP	3001918	A1	4/2016
2017/0297892	A1	10/2017	Li et al.	EP	3007305	A1	4/2016
2017/0301898	A1	10/2017	Lin et al.	EP	3012213	A1	4/2016
2017/0302089	A1	10/2017	Bernauer et al.	EP	3016233	A1	5/2016
2017/0302324	A1	10/2017	Stanimirovic et al.	EP	3023016	A1	5/2016
2017/0303597	A1	10/2017	Tsui	EP	3023351	A1	5/2016
2017/0311648	A1	11/2017	Gill et al.	EP	3023947	A1	5/2016
2017/0318860	A1	11/2017	Adair	EP	3025598	A1	6/2016
2017/0318861	A1	11/2017	Thorens	EP	3026779	A1	6/2016
2017/0325503	A1	11/2017	Liu	EP	3031338	A1	6/2016
2017/0325504	A1	11/2017	Liu	EP	3047742	A1	7/2016
2017/0325506	A1	11/2017	Batista	EP	3056099	A1	8/2016
2017/0332695	A1	11/2017	Zappoli et al.	EP	3061358	A1	8/2016
2017/0333415	A1	11/2017	Williams	EP	3075270	A1	10/2016
2017/0333650	A1	11/2017	Buchberger et al.	EP	3075271	A1	10/2016
2017/0333651	A1	11/2017	Qiu	EP	3081102	A1	10/2016
2017/0334605	A1	11/2017	Murphy et al.	EP	3085638	A1	10/2016
2017/0367406	A1	12/2017	Schuler et al.	EP	3087853	A1	11/2016
2018/0000160	A1	1/2018	Taschner et al.	EP	3097803	A1	11/2016
2018/0037381	A1	2/2018	White et al.	EP	3103355	A1	12/2016
2018/0042306	A1	2/2018	Atkins et al.	EP	3103356	A1	12/2016
2018/0043114	A1	2/2018	Bowen et al.	EP	3111787	A1	1/2017
2018/0043115	A1	2/2018	Gould et al.	EP	3130238	A1	2/2017
2018/0077967	A1	3/2018	Hatton et al.	EP	3132843	A1	2/2017
2018/0093050	A1	4/2018	Stenzler et al.	EP	3135139	A1	3/2017
2018/0093051	A1	4/2018	Stenzler et al.	EP	3135603	A1	3/2017

FOREIGN PATENT DOCUMENTS

AU	2014206215	A1	8/2014	EP	3143882	A3	3/2017
AU	2014208287	A1	8/2014	EP	3143884	A3	4/2017
AU	2017202891	A1	5/2017	EP	3155908	A1	4/2017
CA	2641869	A1	5/2010	EP	3158880	A1	4/2017
CN	1122213	A	5/1996	EP	3158881	A1	4/2017
CN	201018481	Y	2/2008	EP	3195738	A2	7/2017
CN	201430916	Y	3/2010	EP	3165102	A3	8/2017
CN	101869356	A	10/2010	EP	3199043	A1	8/2017
CN	301547686	S	5/2011	EP	3205220	A1	8/2017
CN	301970169	S	6/2012	EP	3205597	A1	8/2017
CN	102754924	A	10/2012	EP	3213649	A1	9/2017
CN	302396126	S	4/2013	ES	3225118	A1	10/2017
CN	103141944	A	6/2013	GB	3228198	A1	10/2017
CN	302799554	S	4/2014	GB	3228345	A1	10/2017
CN	302810246	S	4/2014	IE	2118034	A1	9/1998
CN	302884434	S	8/2014	JP	1025630	A	4/1966
CN	302926289	S	8/2014	JP	1065678	A	4/1967
CN	302950830	S	9/2014	JP	2533174	A	6/2016
CN	303089422	S	1/2015	JP	S20050615		9/2005
CN	303091331	S	1/2015	JP	62278975		12/1987
CN	303103390	S	2/2015	JP	H06114105	A	4/1994
CN	303210086	S	5/2015	JP	09-075058		3/1997
CN	303103389	S	11/2015	JP	H09075058	A	3/1997
CN	303568163	S	1/2016	JP	11178563		6/1999
DE	9410665	U1	10/1994	JP	2000203639	A	7/2000
DE	19854005	A1	5/2000	JP	2000236865	A	9/2000
DE	19854012	A1	5/2000	JP	2001161819	A	6/2001
EM	002626416-001		4/2015	JP	2001165437	A	6/2001
EM	002626416-002		4/2015	JP	2006320285	A	11/2006
EP	0283672	A2	9/1988	JP	2006320286	A	11/2006
EP	0358114	A2	3/1990	JP	2009213428	A	9/2009
EP	0503767	A1	9/1992	JP	2010020929	A	1/2010
				JP	2011024430	A	2/2011
				JP	2012005412	A	1/2012
				JP	5387257	B2	1/2014

US D842,536 S

JP	2015504669	A	2/2015	WO	WO-2014101401	A1	7/2014
JP	201712730	A	1/2017	WO	WO-2014101734	A1	7/2014
TW	201436722	A	10/2014	WO	WO-2014106323	A1	7/2014
TW	201438608	A	10/2014	WO	WO-2014110761	A1	7/2014
TW	201524383	A	7/2015	WO	WO-2014113949	A1	7/2014
WO	WO-9712639	A1	4/1997	WO	WO-2014117382	A1	8/2014
WO	WO-2000005976	A1	2/2000	WO	WO-2014121509	A1	8/2014
WO	WO-0028842	A1	5/2000	WO	WO-2014125340	A1	8/2014
WO	WO-03055486	A1	7/2003	WO	WO-2014127446	A1	8/2014
WO	WO-03056948	A1	7/2003	WO	WO-2014134781	A1	9/2014
WO	WO-03082031	A1	10/2003	WO	WO-2014144678	A2	9/2014
WO	WO-03101454	A1	12/2003	WO	WO-2014146270	A1	9/2014
WO	WO-2004064548	A1	8/2004	WO	WO-2014147470	A2	9/2014
WO	WO-2004080216	A1	9/2004	WO	WO-2014161181	A1	10/2014
WO	WO-2005020726	A1	3/2005	WO	WO-2014166039	A1	10/2014
WO	WO-2005060366	A2	7/2005	WO	WO-2014167530	A1	10/2014
WO	WO-2006021153	A1	3/2006	WO	WO-2014169437	A1	10/2014
WO	WO-2007066374	A1	6/2007	WO	WO-2014169667	A1	10/2014
WO	WO-2007078273	A1	7/2007	WO	WO-2014185937	A1	11/2014
WO	WO-2007095109	A2	8/2007	WO	WO-2014186983	A1	11/2014
WO	WO-2007117675	A2	10/2007	WO	WO-2014194499	A1	12/2014
WO	WO-2007/141520	A1	12/2007	WO	WO-2014195687	A1	12/2014
WO	WO-2008077271	A1	7/2008	WO	WO-2014198042	A1	12/2014
WO	WO-2008151777	A2	12/2008	WO	WO-2014201610	A1	12/2014
WO	WO-2009003204	A2	1/2009	WO	WO-2014201611	A1	12/2014
WO	WO-2010003480	A1	1/2010	WO	WO-2014201646	A1	12/2014
WO	WO-2010118122	A1	10/2010	WO	WO-2014201664	A1	12/2014
WO	WO-2010118644	A1	10/2010	WO	WO-2014201666	A1	12/2014
WO	WO-2010140841	A2	12/2010	WO	WO-2014201668	A1	12/2014
WO	WO-2010144637	A1	12/2010	WO	WO-2014205749	A1	12/2014
WO	WO-2010145805	A1	12/2010	WO	WO-2014205780	A1	12/2014
WO	WO-2011010334	A1	1/2011	WO	WO-2014205807	A1	12/2014
WO	WO-2011050964	A1	5/2011	WO	WO-2014205811	A1	12/2014
WO	WO-2011125058	A1	10/2011	WO	WO-2014206148	A1	12/2014
WO	WO-2012019533	A1	2/2012	WO	WO-2015000125	A1	1/2015
WO	WO-2012043941	A1	4/2012	WO	WO-2015000180	A1	1/2015
WO	WO-2012062600	A1	5/2012	WO	WO-2015003327	A1	1/2015
WO	WO-2012088675	A1	7/2012	WO	WO-2015003372	A1	1/2015
WO	WO-2012091249	A1	7/2012	WO	WO-2015003374	A1	1/2015
WO	WO-2012100523	A1	8/2012	WO	WO-2015006929	A1	1/2015
WO	WO-2012129812	A1	10/2012	WO	WO-2015010242	A1	1/2015
WO	WO-2012134117	A2	10/2012	WO	WO-2015010277	A1	1/2015
WO	WO-2012164033	A1	12/2012	WO	WO-2015010284	A1	1/2015
WO	WO-2012173322	A1	12/2012	WO	WO-2015010291	A1	1/2015
WO	WO-2012174677	A1	12/2012	WO	WO-2015010310	A1	1/2015
WO	WO-D079112-0010		12/2012	WO	WO-2015010336	A1	1/2015
WO	WO-2013012157	A1	1/2013	WO	WO-2015010345	A1	1/2015
WO	WO-2013020220	A1	2/2013	WO	WO-2015010349	A1	1/2015
WO	WO-2013030202	A1	3/2013	WO	WO-2015013890	A1	2/2015
WO	WO-2013034453	A1	3/2013	WO	WO-2015013891	A1	2/2015
WO	WO-2013040193	A2	3/2013	WO	WO-2015013892	A1	2/2015
WO	WO-2013044537	A1	4/2013	WO	WO-2015013926	A1	2/2015
WO	WO-2013076750	A1	5/2013	WO	WO-2015013950	A1	2/2015
WO	WO-2013083635	A1	6/2013	WO	WO-2015013967	A1	2/2015
WO	WO-2013089551	A1	6/2013	WO	WO-2015015156	A1	2/2015
WO	WO-2013110208	A1	8/2013	WO	WO-2015017971	A1	2/2015
WO	WO-2013110209	A1	8/2013	WO	WO-2015018026	A1	2/2015
WO	WO-2013110210	A1	8/2013	WO	WO-2015018120	A1	2/2015
WO	WO-2013113173	A1	8/2013	WO	WO-2015021612	A1	2/2015
WO	WO-2013113174	A1	8/2013	WO	WO-2015021646	A1	2/2015
WO	WO-2013113612	A1	8/2013	WO	WO-2015021651	A1	2/2015
WO	WO-2013116983	A1	8/2013	WO	WO-2015021652	A1	2/2015
WO	WO-2013131763	A1	9/2013	WO	WO-2015021655	A1	2/2015
WO	WO-2013142678	A1	9/2013	WO	WO-2015021658	A1	2/2015
WO	WO-2013150406	A2	10/2013	WO	WO-2015024239	A1	2/2015
WO	WO-2013156658	A1	10/2013	WO	WO-2015024247	A1	2/2015
WO	WO-2013165878	A1	11/2013	WO	WO-2015026081	A1	2/2015
WO	WO-2013171206	A1	11/2013	WO	WO-2015027383	A1	3/2015
WO	WO-2013174001	A1	11/2013	WO	WO-2015027435	A1	3/2015
WO	WO-2014020539	A1	2/2014	WO	WO-2015027436	A1	3/2015
WO	WO-2014020953	A1	2/2014	WO	WO-2015027470	A1	3/2015
WO	WO-2014023171	A1	2/2014	WO	WO-2015028815	A1	3/2015
WO	WO-2014032280	A1	3/2014	WO	WO-2015032050	A1	3/2015
WO	WO-2014040915	A1	3/2014	WO	WO-2015032055	A1	3/2015
WO	WO-2014047948	A1	4/2014	WO	WO-2015032078	A1	3/2015
WO	WO-2014047955	A1	4/2014	WO	WO-2015032093	A1	3/2015
WO	WO-2014067236	A1	5/2014	WO	WO-2015035510	A1	3/2015
WO	WO-2014071747	A1	5/2014	WO	WO-2015035547	A1	3/2015
WO	WO-2014101119	A1	7/2014	WO	WO-2015035557	A1	3/2015

US D842,536 S

WO	WO-2015035587	A1	3/2015	WO	WO-2015161406	A1	10/2015
WO	WO-2015035623	A1	3/2015	WO	WO-2015161407	A1	10/2015
WO	WO-2015035689	A1	3/2015	WO	WO-2015161485	A1	10/2015
WO	WO-2015037925	A1	3/2015	WO	WO-2015161486	A1	10/2015
WO	WO-2015039275	A1	3/2015	WO	WO-2015161491	A1	10/2015
WO	WO-2015039280	A1	3/2015	WO	WO-2015161514	A1	10/2015
WO	WO-2015039332	A1	3/2015	WO	WO-2015161553	A1	10/2015
WO	WO-2015042790	A1	4/2015	WO	WO-2015161555	A1	10/2015
WO	WO-2015042811	A1	4/2015	WO	WO-2015161557	A1	10/2015
WO	WO-2015042848	A1	4/2015	WO	WO-2015068044	A3	11/2015
WO	WO-2015042943	A1	4/2015	WO	WO-2015165067	A1	11/2015
WO	WO-2015051509	A1	4/2015	WO	WO-2015165081	A1	11/2015
WO	WO-2015051538	A1	4/2015	WO	WO-2015165083	A1	11/2015
WO	WO-2015054815	A1	4/2015	WO	WO-2015165086	A1	11/2015
WO	WO-2015054961	A1	4/2015	WO	WO-2015165105	A1	11/2015
WO	WO-2015055314	A1	4/2015	WO	WO-2015165146	A1	11/2015
WO	WO-2015058340	A1	4/2015	WO	WO-2015168827	A1	11/2015
WO	WO-2015058341	A1	4/2015	WO	WO-2015168828	A1	11/2015
WO	WO-2015058367	A1	4/2015	WO	WO-2015168853	A1	11/2015
WO	WO-2015058387	A1	4/2015	WO	WO-2015168904	A1	11/2015
WO	WO-2015062041	A1	5/2015	WO	WO-2015168912	A1	11/2015
WO	WO-2015066136	A1	5/2015	WO	WO-2015172331	A1	11/2015
WO	WO-2015066927	A1	5/2015	WO	WO-2015172361	A1	11/2015
WO	WO-2015070398	A1	5/2015	WO	WO-2015172368	A1	11/2015
WO	WO-2015070405	A1	5/2015	WO	WO-2015172382	A1	11/2015
WO	WO-2015071703	A1	5/2015	WO	WO-2015172383	A1	11/2015
WO	WO-2015073975	A1	5/2015	WO	WO-2015172384	A1	11/2015
WO	WO-2015074187	A1	5/2015	WO	WO-2015172387	A1	11/2015
WO	WO-2015074265	A1	5/2015	WO	WO-2015172388	A1	11/2015
WO	WO-2015074308	A1	5/2015	WO	WO-2015172389	A1	11/2015
WO	WO-2015077998	A1	6/2015	WO	WO-2015172390	A1	11/2015
WO	WO-2015077999	A1	6/2015	WO	WO-2015172606	A1	11/2015
WO	WO-2015078010	A1	6/2015	WO	WO-2015174657	A1	11/2015
WO	WO-2015079197	A1	6/2015	WO	WO-2015174708	A1	11/2015
WO	WO-2015089711	A1	6/2015	WO	WO-2015175979	A1	11/2015
WO	WO-2015091346	A2	6/2015	WO	WO-2015176210	A1	11/2015
WO	WO-2015013327	A3	7/2015	WO	WO-2015176230	A1	11/2015
WO	WO-2015106434	A1	7/2015	WO	WO-2015176300	A1	11/2015
WO	WO-2015106440	A1	7/2015	WO	WO-2015176580	A1	11/2015
WO	WO-2015107551	A2	7/2015	WO	WO-2015180027	A1	12/2015
WO	WO-2015107552	A1	7/2015	WO	WO-2015180061	A1	12/2015
WO	WO-2015109476	A1	7/2015	WO	WO-2015180062	A1	12/2015
WO	WO-2015109532	A1	7/2015	WO	WO-2015180071	A1	12/2015
WO	WO-2015109540	A1	7/2015	WO	WO-2015180088	A1	12/2015
WO	WO-2015109616	A1	7/2015	WO	WO-2015180089	A1	12/2015
WO	WO-2015109618	A1	7/2015	WO	WO-2015180145	A1	12/2015
WO	WO-2015117285	A1	8/2015	WO	WO-2015184580	A1	12/2015
WO	WO-2015120588	A1	8/2015	WO	WO-2015184590	A1	12/2015
WO	WO-2015120591	A1	8/2015	WO	WO-2015184620	A1	12/2015
WO	WO-2015120623	A1	8/2015	WO	WO-2015184747	A1	12/2015
WO	WO-2015123831	A1	8/2015	WO	WO-2015188295	A1	12/2015
WO	WO-2015127609	A1	9/2015	WO	WO-2015188296	A1	12/2015
WO	WO-2015128599	A1	9/2015	WO	WO-2015189613	A1	12/2015
WO	WO-2015137815	A1	9/2015	WO	WO-2015190810	A1	12/2015
WO	WO-2015140312	A1	9/2015	WO	WO-2015192301	A1	12/2015
WO	WO-2015140336	A1	9/2015	WO	WO-2015192326	A1	12/2015
WO	WO-2015140768	A2	9/2015	WO	WO-2015192336	A1	12/2015
WO	WO-2015143637	A1	10/2015	WO	WO-2015192337	A1	12/2015
WO	WO-2015143648	A1	10/2015	WO	WO-2015192377	A1	12/2015
WO	WO-2015143749	A1	10/2015	WO	WO-2015193456	A1	12/2015
WO	WO-2015143765	A1	10/2015	WO	WO-2015196331	A1	12/2015
WO	WO-2015144057	A1	10/2015	WO	WO-2015196332	A1	12/2015
WO	WO-2015149311	A1	10/2015	WO	WO-2015196357	A1	12/2015
WO	WO-2015149330	A1	10/2015	WO	WO-2015196367	A1	12/2015
WO	WO-2015149332	A1	10/2015	WO	WO-2015196395	A1	12/2015
WO	WO-2015149338	A1	10/2015	WO	WO-2015196463	A1	12/2015
WO	WO-2015149368	A1	10/2015	WO	WO-2015148649	A3	1/2016
WO	WO-2015149403	A1	10/2015	WO	WO-2016000113	A1	1/2016
WO	WO-2015149406	A1	10/2015	WO	WO-2016000130	A1	1/2016
WO	WO-2015150068	A1	10/2015	WO	WO-2016000135	A1	1/2016
WO	WO-2015154309	A1	10/2015	WO	WO-2016000136	A1	1/2016
WO	WO-2015154619	A1	10/2015	WO	WO-2016000139	A1	1/2016
WO	WO-2015157891	A1	10/2015	WO	WO-2016000206	A1	1/2016
WO	WO-2015157893	A1	10/2015	WO	WO-2016000207	A1	1/2016
WO	WO-2015157900	A1	10/2015	WO	WO-2016000214	A1	1/2016
WO	WO-2015157901	A1	10/2015	WO	WO-2016000232	A1	1/2016
WO	WO-2015157928	A1	10/2015	WO	WO-2016000233	A1	1/2016
WO	WO-2015158522	A1	10/2015	WO	WO-2016000305	A1	1/2016
WO	WO-2015158548	A1	10/2015	WO	WO-2016008067	A1	1/2016

US D842,536 S

Page 21

WO	WO-2016008096	A1	1/2016	WO	WO-2016065521	A1	5/2016
WO	WO-2016008217	A1	1/2016	WO	WO-2016065532	A1	5/2016
WO	WO-2016009202	A1	1/2016	WO	WO-2016065533	A1	5/2016
WO	WO-2016011573	A1	1/2016	WO	WO-2016065596	A1	5/2016
WO	WO-2016012769	A1	1/2016	WO	WO-2016065598	A1	5/2016
WO	WO-2016015196	A1	2/2016	WO	WO-2016065599	A1	5/2016
WO	WO-2016015245	A1	2/2016	WO	WO-2016065605	A1	5/2016
WO	WO-2016015246	A1	2/2016	WO	WO-2016065606	A1	5/2016
WO	WO-2016015247	A1	2/2016	WO	WO-2016065607	A1	5/2016
WO	WO-2016015264	A1	2/2016	WO	WO-2016070553	A1	5/2016
WO	WO-2016015712	A1	2/2016	WO	WO-2016071027	A1	5/2016
WO	WO-2016019353	A1	2/2016	WO	WO-2016071705	A1	5/2016
WO	WO-2016019508	A1	2/2016	WO	WO-2016071706	A1	5/2016
WO	WO-2016019550	A1	2/2016	WO	WO-2016074228	A1	5/2016
WO	WO-2016019573	A1	2/2016	WO	WO-2016074229	A1	5/2016
WO	WO-2016020675	A1	2/2016	WO	WO-2016074230	A1	5/2016
WO	WO-2016023173	A1	2/2016	WO	WO-2016074234	A1	5/2016
WO	WO-2016023176	A1	2/2016	WO	WO-2016074237	A1	5/2016
WO	WO-2016023177	A1	2/2016	WO	WO-2016076178	A1	5/2016
WO	WO-2016023181	A1	2/2016	WO	WO-2016079001	A1	5/2016
WO	WO-2016023182	A1	2/2016	WO	WO-2016079151	A1	5/2016
WO	WO-2016023183	A1	2/2016	WO	WO-2016079152	A1	5/2016
WO	WO-2016023212	A1	2/2016	WO	WO-2016079155	A1	5/2016
WO	WO-2016023651	A1	2/2016	WO	WO-2016079468	A1	5/2016
WO	WO-2016023824	A1	2/2016	WO	WO-2016079533	A1	5/2016
WO	WO-2016023965	A1	2/2016	WO	WO-2016079729	A1	5/2016
WO	WO-2016026104	A1	2/2016	WO	WO-2016058992	A3	6/2016
WO	WO-2016026105	A1	2/2016	WO	WO-2016059003	A3	6/2016
WO	WO-2016026156	A1	2/2016	WO	WO-2016082074	A1	6/2016
WO	WO-2016026811	A1	2/2016	WO	WO-2016082103	A1	6/2016
WO	WO-2016028544	A1	2/2016	WO	WO-2016082116	A1	6/2016
WO	WO-2016029344	A1	3/2016	WO	WO-2016082136	A1	6/2016
WO	WO-2016029382	A1	3/2016	WO	WO-2016082158	A1	6/2016
WO	WO-2016029386	A1	3/2016	WO	WO-2016082179	A1	6/2016
WO	WO-2016029389	A1	3/2016	WO	WO-2016082180	A1	6/2016
WO	WO-2016029429	A1	3/2016	WO	WO-2016082183	A1	6/2016
WO	WO-2016029464	A1	3/2016	WO	WO-2016082217	A1	6/2016
WO	WO-2016029468	A1	3/2016	WO	WO-2016082232	A1	6/2016
WO	WO-2016029470	A1	3/2016	WO	WO-2016082479	A1	6/2016
WO	WO-2016029473	A1	3/2016	WO	WO-2016086382	A1	6/2016
WO	WO-2016029567	A1	3/2016	WO	WO-2016090426	A1	6/2016
WO	WO-2016030661	A1	3/2016	WO	WO-2016090531	A1	6/2016
WO	WO-2016033721	A1	3/2016	WO	WO-2016090533	A1	6/2016
WO	WO-2016033734	A1	3/2016	WO	WO-2016090593	A1	6/2016
WO	WO-2016033783	A1	3/2016	WO	WO-2016090601	A1	6/2016
WO	WO-2016033817	A1	3/2016	WO	WO-2016090602	A1	6/2016
WO	WO-2016034100	A1	3/2016	WO	WO-2016090962	A1	6/2016
WO	WO-2016038029	A1	3/2016	WO	WO-2016092259	A1	6/2016
WO	WO-2016040575	A1	3/2016	WO	WO-2016095101	A1	6/2016
WO	WO-2016041114	A1	3/2016	WO	WO-2016095206	A1	6/2016
WO	WO-2016041140	A1	3/2016	WO	WO-2016095220	A1	6/2016
WO	WO-2016041141	A1	3/2016	WO	WO-2016095234	A1	6/2016
WO	WO-2016041207	A1	3/2016	WO	WO-2016095297	A1	6/2016
WO	WO-2016041209	A1	3/2016	WO	WO-2016096337	A1	6/2016
WO	WO-2016045058	A1	3/2016	WO	WO-2016096482	A1	6/2016
WO	WO-2016046116	A1	3/2016	WO	WO-2016096497	A1	6/2016
WO	WO-2015192834	A3	4/2016	WO	WO-2016096733	A1	6/2016
WO	WO-2016049822	A1	4/2016	WO	WO-2016096762	A1	6/2016
WO	WO-2016049823	A1	4/2016	WO	WO-2016099045	A1	6/2016
WO	WO-2016049855	A1	4/2016	WO	WO-2016099276	A1	6/2016
WO	WO-2016049863	A1	4/2016	WO	WO-2016101141	A1	6/2016
WO	WO-2016050246	A1	4/2016	WO	WO-2016101142	A1	6/2016
WO	WO-2016050247	A1	4/2016	WO	WO-2016101143	A1	6/2016
WO	WO-2016054793	A1	4/2016	WO	WO-2016101144	A1	6/2016
WO	WO-2016055653	A1	4/2016	WO	WO-2016101150	A1	6/2016
WO	WO-2016058139	A1	4/2016	WO	WO-2016101183	A1	6/2016
WO	WO-2016058187	A1	4/2016	WO	WO-2016101200	A1	6/2016
WO	WO-2016058189	A1	4/2016	WO	WO-2016101202	A1	6/2016
WO	WO-2016059000	A1	4/2016	WO	WO-2016101203	A1	6/2016
WO	WO-2016060576	A1	4/2016	WO	WO-2016101248	A1	6/2016
WO	WO-2016061729	A1	4/2016	WO	WO-2016103202	A1	6/2016
WO	WO-2016061730	A1	4/2016	WO	WO-2016105191	A1	6/2016
WO	WO-2016061822	A1	4/2016	WO	WO-2016036236	A3	7/2016
WO	WO-2016061859	A1	4/2016	WO	WO-2016106476	A1	7/2016
WO	WO-2016062168	A1	4/2016	WO	WO-2016106483	A1	7/2016
WO	WO-2016062777	A1	4/2016	WO	WO-2016106493	A1	7/2016
WO	WO-2016063775	A1	4/2016	WO	WO-2016106495	A1	7/2016
WO	WO-2017068098	A1	4/2016	WO	WO-2016106499	A1	7/2016
WO	WO-2016065520	A1	5/2016	WO	WO-2016106500	A1	7/2016

US D842,536 S

Page 22

WO	WO-2016106512	A1	7/2016	WO	WO-2016141593	A1	9/2016
WO	WO-2016108693	A1	7/2016	WO	WO-2016145611	A1	9/2016
WO	WO-2016108694	A1	7/2016	WO	WO-2016145612	A1	9/2016
WO	WO-2016109929	A1	7/2016	WO	WO-2016145613	A1	9/2016
WO	WO-2016109930	A1	7/2016	WO	WO-2016145634	A1	9/2016
WO	WO-2016109931	A1	7/2016	WO	WO-2016145656	A1	9/2016
WO	WO-2016109932	A1	7/2016	WO	WO-2016145663	A1	9/2016
WO	WO-2016109933	A1	7/2016	WO	WO-2016149896	A1	9/2016
WO	WO-2016109942	A1	7/2016	WO	WO-2016149932	A1	9/2016
WO	WO-2016109964	A1	7/2016	WO	WO-2016149942	A1	9/2016
WO	WO-2016109965	A1	7/2016	WO	WO-2016150019	A1	9/2016
WO	WO-2016110522	A1	7/2016	WO	WO-2016150979	A1	9/2016
WO	WO-2016112491	A1	7/2016	WO	WO-2016154792	A1	10/2016
WO	WO-2016112493	A1	7/2016	WO	WO-2016154797	A1	10/2016
WO	WO-2016112533	A1	7/2016	WO	WO-2016154798	A1	10/2016
WO	WO-2016112534	A1	7/2016	WO	WO-2016154815	A1	10/2016
WO	WO-2016112541	A1	7/2016	WO	WO-2016154895	A1	10/2016
WO	WO-2016112542	A1	7/2016	WO	WO-2016154896	A1	10/2016
WO	WO-2016112561	A1	7/2016	WO	WO-2016154897	A1	10/2016
WO	WO-2016112579	A1	7/2016	WO	WO-2016154900	A1	10/2016
WO	WO-2016115689	A1	7/2016	WO	WO-2016154994	A1	10/2016
WO	WO-2016115691	A1	7/2016	WO	WO-2016155003	A1	10/2016
WO	WO-2016115701	A1	7/2016	WO	WO-2016155103	A1	10/2016
WO	WO-2016115715	A1	7/2016	WO	WO-2016155104	A1	10/2016
WO	WO-2016116754	A1	7/2016	WO	WO-2016155105	A1	10/2016
WO	WO-2016116755	A1	7/2016	WO	WO-2016155316	A1	10/2016
WO	WO-2016118005	A1	7/2016	WO	WO-2016156103	A1	10/2016
WO	WO-2016119098	A1	8/2016	WO	WO-2016156217	A1	10/2016
WO	WO-2016119099	A1	8/2016	WO	WO-2016156413	A1	10/2016
WO	WO-2016119101	A1	8/2016	WO	WO-2016161554	A1	10/2016
WO	WO-2016119119	A1	8/2016	WO	WO-2016161673	A1	10/2016
WO	WO-2016119121	A1	8/2016	WO	WO-2016162446	A1	10/2016
WO	WO-2016119144	A1	8/2016	WO	WO-2016162492	A1	10/2016
WO	WO-2016119145	A1	8/2016	WO	WO-2016165055	A1	10/2016
WO	WO-2016119163	A1	8/2016	WO	WO-2016165057	A1	10/2016
WO	WO-2016119167	A1	8/2016	WO	WO-2016165063	A1	10/2016
WO	WO-2016119170	A1	8/2016	WO	WO-2016165125	A1	10/2016
WO	WO-2016119225	A1	8/2016	WO	WO-2016166049	A1	10/2016
WO	WO-2016119248	A1	8/2016	WO	WO-2016166456	A1	10/2016
WO	WO-2016119273	A1	8/2016	WO	WO-2016166661	A1	10/2016
WO	WO-2016119496	A1	8/2016	WO	WO-2016166670	A1	10/2016
WO	WO-2016122417	A1	8/2016	WO	WO-2016168274	A1	10/2016
WO	WO-2016123763	A1	8/2016	WO	WO-2016168986	A1	10/2016
WO	WO-2016123764	A1	8/2016	WO	WO-2016169019	A1	10/2016
WO	WO-2016123770	A1	8/2016	WO	WO-2016169052	A1	10/2016
WO	WO-2016123779	A1	8/2016	WO	WO-2016169063	A1	10/2016
WO	WO-2016123780	A1	8/2016	WO	WO-2016169669	A1	10/2016
WO	WO-2016123781	A1	8/2016	WO	WO-2016169796	A1	10/2016
WO	WO-2016124017	A1	8/2016	WO	WO-2016169797	A1	10/2016
WO	WO-2016124019	A1	8/2016	WO	WO-2016172802	A1	11/2016
WO	WO-2016124695	A1	8/2016	WO	WO-2016172821	A1	11/2016
WO	WO-2016124740	A1	8/2016	WO	WO-2016172843	A1	11/2016
WO	WO-2016124741	A1	8/2016	WO	WO-2016172847	A1	11/2016
WO	WO-2016127287	A1	8/2016	WO	WO-2016172867	A1	11/2016
WO	WO-2016127293	A1	8/2016	WO	WO-2016172898	A1	11/2016
WO	WO-2016127327	A1	8/2016	WO	WO-2016172907	A1	11/2016
WO	WO-2016127360	A1	8/2016	WO	WO-2016172908	A1	11/2016
WO	WO-2016127361	A1	8/2016	WO	WO-2016172909	A1	11/2016
WO	WO-2016127389	A1	8/2016	WO	WO-2016172954	A1	11/2016
WO	WO-2016127390	A1	8/2016	WO	WO-2016174179	A1	11/2016
WO	WO-2016127396	A1	8/2016	WO	WO-2016176800	A1	11/2016
WO	WO-2016127397	A1	8/2016	WO	WO-2016177604	A1	11/2016
WO	WO-2016127401	A1	8/2016	WO	WO-2016179356	A1	11/2016
WO	WO-2016127406	A1	8/2016	WO	WO-2016179664	A1	11/2016
WO	WO-2016127468	A1	8/2016	WO	WO-2016179776	A1	11/2016
WO	WO-2016127839	A1	8/2016	WO	WO-2016179828	A1	11/2016
WO	WO-2016128562	A1	8/2016	WO	WO-2016183724	A1	11/2016
WO	WO-2016131755	A1	8/2016	WO	WO-2016184247	A1	11/2016
WO	WO-2016132026	A1	8/2016	WO	WO-2016184824	A1	11/2016
WO	WO-2016134544	A1	9/2016	WO	WO-2016171997	A3	12/2016
WO	WO-2016135503	A1	9/2016	WO	WO-2016187803	A1	12/2016
WO	WO-2016138608	A1	9/2016	WO	WO-2016187943	A1	12/2016
WO	WO-2016138665	A1	9/2016	WO	WO-2016188140	A1	12/2016
WO	WO-2016138689	A1	9/2016	WO	WO-2016188141	A1	12/2016
WO	WO-2016141508	A1	9/2016	WO	WO-2016188142	A1	12/2016
WO	WO-2016141555	A1	9/2016	WO	WO-2016188967	A1	12/2016
WO	WO-2016141556	A1	9/2016	WO	WO-2016189086	A1	12/2016
WO	WO-2016141581	A1	9/2016	WO	WO-2016191946	A1	12/2016
WO	WO-2016141592	A1	9/2016	WO	WO-2016193336	A1	12/2016

US D842,536 S

WO	WO-2016193365	A1	12/2016	WO	WO-2017036879	A1	3/2017
WO	WO-2016193743	A1	12/2016	WO	WO-2017041251	A1	3/2017
WO	WO-2016197485	A1	12/2016	WO	WO-2017042081	A1	3/2017
WO	WO-2016197658	A1	12/2016	WO	WO-2017045132	A1	3/2017
WO	WO-2016198417	A1	12/2016	WO	WO-2017045897	A1	3/2017
WO	WO-2016198459	A1	12/2016	WO	WO-2017045898	A1	3/2017
WO	WO-2016198879	A1	12/2016	WO	WO-2017045899	A1	3/2017
WO	WO-2016199062	A1	12/2016	WO	WO-2017046247	A1	3/2017
WO	WO-2016199065	A1	12/2016	WO	WO-2017046334	A1	3/2017
WO	WO-2016199066	A1	12/2016	WO	WO-2017046363	A1	3/2017
WO	WO-2016200252	A1	12/2016	WO	WO-2017046566	A1	3/2017
WO	WO-2016200253	A1	12/2016	WO	WO-2017049653	A1	3/2017
WO	WO-2016200255	A1	12/2016	WO	WO-2017049654	A1	3/2017
WO	WO-2016200259	A1	12/2016	WO	WO-2017051150	A1	3/2017
WO	WO-2016200382	A1	12/2016	WO	WO-2017051174	A1	3/2017
WO	WO-2016201602	A1	12/2016	WO	WO-2017051348	A1	3/2017
WO	WO-2016201606	A1	12/2016	WO	WO-2017051349	A1	3/2017
WO	WO-2016201911	A1	12/2016	WO	WO-2017046593	A3	4/2017
WO	WO-2016202028	A1	12/2016	WO	WO-2017054424	A1	4/2017
WO	WO-2016202033	A1	12/2016	WO	WO-2017054627	A1	4/2017
WO	WO-2016202301	A1	12/2016	WO	WO-2017054634	A1	4/2017
WO	WO-2016202302	A1	12/2016	WO	WO-2017055564	A1	4/2017
WO	WO-2016202303	A1	12/2016	WO	WO-2017055584	A1	4/2017
WO	WO-2016202304	A1	12/2016	WO	WO-2017055793	A1	4/2017
WO	WO-2016207357	A1	12/2016	WO	WO-2017055795	A1	4/2017
WO	WO-2016208757	A1	12/2016	WO	WO-2017055799	A1	4/2017
WO	WO-2016208760	A1	12/2016	WO	WO-2017055801	A1	4/2017
WO	WO-2016193705	A3	1/2017	WO	WO-2017055802	A1	4/2017
WO	WO-2017000239	A1	1/2017	WO	WO-2017055803	A1	4/2017
WO	WO-2017001270	A1	1/2017	WO	WO-2017055866	A1	4/2017
WO	WO-2017001817	A1	1/2017	WO	WO-2017056103	A1	4/2017
WO	WO-2017001818	A1	1/2017	WO	WO-2017057286	A1	4/2017
WO	WO-2017001819	A1	1/2017	WO	WO-2017059571	A1	4/2017
WO	WO-2017001820	A1	1/2017	WO	WO-2017060279	A1	4/2017
WO	WO-2017005835	A1	1/2017	WO	WO-2017063256	A1	4/2017
WO	WO-2017007252	A1	1/2017	WO	WO-2017063535	A1	4/2017
WO	WO-2017008616	A1	1/2017	WO	WO-2017064051	A1	4/2017
WO	WO-2017009002	A1	1/2017	WO	WO-2017064322	A1	4/2017
WO	WO-2017011419	A1	1/2017	WO	WO-2017064323	A1	4/2017
WO	WO-2017012099	A1	1/2017	WO	WO-2017064324	A1	4/2017
WO	WO-2017012105	A1	1/2017	WO	WO-2017064487	A1	4/2017
WO	WO-2017012257	A1	1/2017	WO	WO-2017066938	A1	4/2017
WO	WO-2017012335	A1	1/2017	WO	WO-2017066955	A1	4/2017
WO	WO-2016172921	A8	2/2017	WO	WO-2017067066	A1	4/2017
WO	WO-2016178098	A3	2/2017	WO	WO-2017067326	A1	4/2017
WO	WO-2017015791	A1	2/2017	WO	WO-2017068099	A1	4/2017
WO	WO-2017015794	A1	2/2017	WO	WO-2017068100	A1	4/2017
WO	WO-2017015832	A1	2/2017	WO	WO-2016096745	A9	5/2017
WO	WO-2017015859	A1	2/2017	WO	WO-2016173568	A3	5/2017
WO	WO-2017016323	A1	2/2017	WO	WO-2016198026	A3	5/2017
WO	WO-2017017970	A1	2/2017	WO	WO-2017051350	A3	5/2017
WO	WO-2017020220	A1	2/2017	WO	WO-2017070871	A1	5/2017
WO	WO-2017020221	A1	2/2017	WO	WO-2017071297	A1	5/2017
WO	WO-2017020275	A1	2/2017	WO	WO-2017071298	A1	5/2017
WO	WO-2017020290	A1	2/2017	WO	WO-2017072239	A1	5/2017
WO	WO-2017023589	A1	2/2017	WO	WO-2017072277	A1	5/2017
WO	WO-2017024477	A1	2/2017	WO	WO-2017072284	A1	5/2017
WO	WO-2017024478	A1	2/2017	WO	WO-2017075753	A1	5/2017
WO	WO-2017024799	A1	2/2017	WO	WO-2017075759	A1	5/2017
WO	WO-2017024926	A1	2/2017	WO	WO-2017075827	A1	5/2017
WO	WO-2017025383	A1	2/2017	WO	WO-2017075883	A1	5/2017
WO	WO-2017028167	A1	2/2017	WO	WO-2017075975	A1	5/2017
WO	WO-2017028295	A1	2/2017	WO	WO-2017076247	A1	5/2017
WO	WO-2017029268	A1	2/2017	WO	WO-2017076590	A1	5/2017
WO	WO-2017029269	A1	2/2017	WO	WO-2017081480	A1	5/2017
WO	WO-2017029270	A1	2/2017	WO	WO-2017082728	A1	5/2017
WO	WO-2017021536	A3	3/2017	WO	WO-2017084107	A1	5/2017
WO	WO-2017031662	A1	3/2017	WO	WO-2017084488	A1	5/2017
WO	WO-2017031678	A1	3/2017	WO	WO-2017084489	A1	5/2017
WO	WO-2017031681	A1	3/2017	WO	WO-2017084818	A1	5/2017
WO	WO-2017033007	A1	3/2017	WO	WO-2017084848	A1	5/2017
WO	WO-2017033021	A1	3/2017	WO	WO-2017084849	A1	5/2017
WO	WO-2017033132	A1	3/2017	WO	WO-2017084920	A2	5/2017
WO	WO-2017035720	A1	3/2017	WO	WO-2017085240	A1	5/2017
WO	WO-2017036818	A1	3/2017	WO	WO-2017085242	A1	5/2017
WO	WO-2017036819	A1	3/2017	WO	WO-2017081176	A3	6/2017
WO	WO-2017036828	A1	3/2017	WO	WO-2017088660	A1	6/2017
WO	WO-2017036829	A1	3/2017	WO	WO-2017089931	A1	6/2017
WO	WO-2017036865	A1	3/2017	WO	WO-2017091926	A1	6/2017

WO WO-2017092144 A1 6/2017
 WO WO-2017093452 A1 6/2017
 WO WO-2017093535 A1 6/2017
 WO WO-2017096512 A1 6/2017
 WO WO-2017096971 A1 6/2017
 WO WO-2017096988 A1 6/2017
 WO WO-2017097172 A1 6/2017
 WO WO-2017097173 A1 6/2017
 WO WO-2017097821 A1 6/2017
 WO WO-2017101030 A1 6/2017
 WO WO-2017101058 A1 6/2017
 WO WO-2017101705 A1 6/2017
 WO WO-2017102633 A1 6/2017
 WO WO-2017102686 A1 6/2017
 WO WO-2017102969 A1 6/2017
 WO WO-2017107546 A1 6/2017
 WO WO-2017108268 A1 6/2017
 WO WO-2017108392 A1 6/2017
 WO WO-2017108394 A1 6/2017
 WO WO-2017108429 A1 6/2017
 WO WO-2017109448 A2 6/2017
 WO WO-2017109868 A1 6/2017
 WO WO-2017110713 A1 6/2017
 WO WO-2017036426 A3 7/2017
 WO WO-2017113106 A1 7/2017
 WO WO-2017113513 A1 7/2017
 WO WO-2017113845 A1 7/2017
 WO WO-2017114389 A1 7/2017
 WO WO-2017117725 A1 7/2017
 WO WO-2017117742 A1 7/2017
 WO WO-2017118135 A1 7/2017
 WO WO-2017118138 A1 7/2017
 WO WO-2017118347 A1 7/2017
 WO WO-2017121156 A1 7/2017
 WO WO-2017121253 A1 7/2017
 WO WO-2017121296 A1 7/2017
 WO WO-2017121546 A1 7/2017
 WO WO-2017121979 A1 7/2017
 WO WO-2017122196 A1 7/2017
 WO WO-2017124419 A1 7/2017
 WO WO-2017124662 A1 7/2017
 WO WO-2017124957 A1 7/2017
 WO WO-2017128038 A1 8/2017
 WO WO-2017133056 A1 8/2017
 WO WO-2017137138 A1 8/2017
 WO WO-2017137554 A1 8/2017
 WO WO-2017139963 A1 8/2017
 WO WO-2017141017 A1 8/2017
 WO WO-2017141018 A1 8/2017
 WO WO-2017141358 A1 8/2017
 WO WO-2017143494 A1 8/2017
 WO WO-2017143495 A1 8/2017
 WO WO-2017143515 A1 8/2017
 WO WO-2017143865 A1 8/2017
 WO WO-2017143953 A1 8/2017
 WO WO-2017144400 A1 8/2017
 WO WO-2017144861 A1 8/2017
 WO WO-2017149288 A1 9/2017
 WO WO-2017152481 A1 9/2017
 WO WO-2017153051 A1 9/2017
 WO WO-2017153270 A1 9/2017
 WO WO-2017156694 A1 9/2017
 WO WO-2017156695 A1 9/2017
 WO WO-2017156696 A1 9/2017
 WO WO-2017156733 A1 9/2017
 WO WO-2017156743 A1 9/2017
 WO WO-2017161715 A1 9/2017
 WO WO-2017161725 A1 9/2017
 WO WO-2017163044 A1 9/2017
 WO WO-2017163045 A1 9/2017
 WO WO-2017163046 A1 9/2017
 WO WO-2017163047 A1 9/2017
 WO WO-2017163050 A1 9/2017
 WO WO-2017163051 A1 9/2017
 WO WO-2017163052 A1 9/2017
 WO WO-2017164474 A1 9/2017
 WO WO-2017166263 A1 10/2017
 WO WO-2017166334 A1 10/2017
 WO WO-2017167169 A1 10/2017

WO WO-2017167513 A1 10/2017
 WO WO-2017173669 A1 10/2017
 WO WO-2017173947 A1 10/2017
 WO WO-2017173951 A1 10/2017
 WO WO-2017174754 A1 10/2017
 WO WO-2017175166 A1 10/2017
 WO WO-2017176111 A1 10/2017
 WO WO-2017176113 A1 10/2017
 WO WO-2017177897 A1 10/2017

OTHER PUBLICATIONS

“Commission Regulation (EC) No. 1275/2008,” Official Journal of the European Union, Dec. 17, 2008.

“Guideline Accompanying Commission Regulation (EC) No. 1275/2008,” Official Journal of the European Union, Oct. 2009.

“Lighter.” Merriam-Webster Online Dictionary. 2009. Merriam-Webster Online. Jun. 8, 2009 [<http://www.merriam-webster.com/dictionary/lighter>].

AMB. Manual:TranX160/Rev.10-06. published 2004-2006.

Baker et al., “The pyrolysis of tobacco ingredients,” J. Anal. Appl. Pyrolysis, vol. 71, pp. 223-311 (2004).

Bombick, et al. Chemical and biological studies of a new cigarette that primarily heats tobacco. Part 2. In vitro toxicology of mainstream smoke condensate. Food and Chemical Toxicology. 1997; 36:183-190.

Bombick, et al. Chemical and biological studies of a new cigarette that primarily heats tobacco. Part 3. In vitro toxicity of whole smoke. Food and Chemical Toxicology. 1998; 36:191-197.

Borgerding, et al. Chemical and biological studies of a new cigarette that primarily heats tobacco. Part 1. Chemical composition of mainstream smoke. Food and Chemical Toxicology. 1997; 36:169-182.

Breland, Alison, et al. “Electronic cigarettes: what are they and what do they do?.” Annals of the New York Academy of Sciences 1394.1 (2017): 5-30.

Brown, Christopher J., et al., “Electronic cigarettes: product characterisation and design considerations.” Tobacco control 23.suppl 2 (2014): ii4-ii10.

Bullen, et al., “Effect of an electronic nicotine delivery device (e cigarette) on desire to smoke and withdrawal, user preferences and nicotine delivery: randomized cross-over trial,” Tobacco Control, 19(2), pp. 98-103. Apr. 2010.

Burch, et al., “Effect of pH on nicotine absorption and side effects produced by aerosolized nicotine,” Journal of Aerosol Medicine: Deposition, Clearance, and Effects in the Lung, 6(1), pp. 45-52. 1993.

Capponnetto, et al., “Successful smoking cessation with cigarettes in smokers with a documented history of recurring relapses: a case series,” Journal of Medical Case Reports; 5(1), 6 pages. 2011.

Davis & Nielsen, “Marketing, Processing and Storage: Green Leaf Threshing and Redrying Tobacco,” Tobacco Production, Chemistry and Technology, (1999) Section 10B, pp. 330-333, Bill Ward, Expert Leaf Tobacco Company, Wilson, North Carolina, USA.

E-Cigarette Forum; pg-gv-peg (discussion/posting); retrieved from the Internet: <https://e-cigarette-forum.com/forum/threads/pg-gv-peg.177551>; 7 pgs.; Apr. 8, 2011.

ECF; Any interest in determining nicotine—by DVAP; (<https://www.e-cigarette-forum.com/forum/threads/any-interest-in-determining-nicotine-by-dvap.35922/>); blog posts dated: 2009; 8 pgs.; print/retrieval date: Jul. 31, 2014.

Electronic Vaporization Device/ Gizmodo Pax 2 Vaporizer/ Gizmodo; retrieved from <http://gizmodo.com/pax-2-vaporizer-reviews-its-like-smoking-in-the-future-1718310779>; posted Jul. 23, 2015, retrieved Oct. 17, 2016.

Farsalinos, et al., “Electronic cigarettes do not damage the heart,” European Society of Cardiology, 4 pages, (<http://www.escardio.org/The-ESC/Press-Office/Press-releases/Electronic-cigarettes-do-not-damage-the-heart>). Aug. 25, 2012.

Farsalinos, Konstantinos E., et al. “Protocol proposal for, and evaluation of, consistency in nicotine delivery from the liquid to the aerosol of electronic cigarettes atomizers: regulatory implications.” Addiction 111.6 (2016): 1069-1076.

- Farsalinos, Konstantinos E., et al. *Analytical Assessment of e-Cigarettes: From Contents to Chemical and Particle Exposure Profiles*. pp. 1-35. Elsevier, 2016.
- FC Vaporizer Review Forum; Pax Vaporizer by Ploom; retrieved from : <http://fuckcombustion.com/threads/pax-vaporizer-by-ploom.6223/>; pp. 2 & 11 (2 pgs.); retrieval date: Nov. 16, 2015.
- Flouris, et al., "Acute impact of active and passive electronic cigarette smoking on serum cotinine and lung function," *Inhal. Toxicol.*, 25(2), pp. 91-101. Feb. 2013.
- Food & Drug Administration; Warning letter to the Compounding Pharmacy, retrieved Oct. 10, 2014 from <http://www.fda.gov/ICECI/EnforcementActions/WarningLetters/2002/ucm144843.htm>, 3 pages. Apr. 9, 2002.
- Geiss, Otmar, Ivana Bianchi, and Josefa Barrero-Moreno. "Correlation of volatile carbonyl yields emitted by e-cigarettes with the temperature of the heating coil and the perceived sensorial quality of the generated vapours." *International journal of hygiene and environmental health* 219.3 (2016): 268-277.
- Gillman, I. G., et al. "Effect of variable power levels on the yield of total aerosol mass and formation of aldehydes in e-cigarette aerosols." *Regulatory Toxicology and Pharmacology* 75 (2016): 58-65.
- Giorgio, Agostino. "E-Cig Digital Design for the Smoke Control Optimization." *International Journal of Applied Engineering Research* 11.8 (2016): 6018-6023.
- Goniewicz, et al., "Nicotine levels in electronic cigarettes," *Nicotine Tobacco Research*, 15(1), pp. 158-166, Jan. 2013.
- Gregory, Andrew, "E-cigarettes to go on prescription under move to class them as medicines," *Mirror*, Jun. 12, 2013. <http://www.mirror.co.uk/news/uk-news/e-cigarettes-go-prescription-under-move-1949018>.
- Grotenhermen, et al., Developing science-based per se limits for driving under the influence of cannabis (DUIC): findings and recommendations by an expert panel; retrieved Feb. 9, 2017 from (<http://www.canorml.org/healthfacts/DUICreport.2005.pdf>); Sep. 2005.
- Harvest Vapor, American Blend Tobacco (product info), retrieved from the internet (<http://harvestvapor.com/>), 2 pages. Oct. 10, 2014.
- Hurt, et al., "Treating tobacco dependence in a medical setting," *CA: A Cancer Journal for Clinicians*, 59(5), pp. 314-326. Sep. 2009.
- Ijoy. "Who we are." *IJOY Diamond PD270 Kit*, Date Accessed Feb. 20, 2018. www.ijoycig.com/product/item-473.html.
- Inchem; Benzoic Acid; JECFA Evaluation Summary; retrieved Oct. 10, 2014 from http://www.inchem.org/documents/jecfa/feceval/jec_184.htm, 2 pages. May 28, 2005.
- Inchem; Levulinic Acid; JECFA Evaluation Summary; retrieved Oct. 10, 2014 from http://www.inchem.org/documents/jecfa/feceval/jec_1266.htm, 2 pages. Mar. 10, 2003.
- Inchem; Pyruvic Acid; JECFA Evaluation Summary; retrieved Oct. 10, 2014 from http://www.inchem.org/documents/jecfa/feceval/jec_2072.htm, 2 pages. Jan. 29, 2003.
- Inchem; Sorbic Acid; JECFA Evaluation Summary; retrieved Oct. 10, 2014 from http://www.inchem.org/documents/jecfa/feceval/jec_2181.htm, 2 pages. May 29, 2005.
- Ingebretsen et al., "Electronic Cigarette aerosol particle size distribution measurements", *Inhalation Toxicology*, 2012; 24 (14): 976-984.
- Kanger K1 Stabilized Wood DNA 75 BOX MOD—KangerTech*. Date Accessed Feb. 20, 2018. <https://kangeronline.com/products/kanger-k1-stabilized-wood-dna-75-box-mod>.
- Kuo et al. Applications of Turbulent and Multiphase Combustion, Appendix D: Particle Size—U.S. Sieve Size and Tyler Screen Mesh Equivalents, 2012, p. 541-543.
- Marshall, John R., Shahram Lotfipour, and Bharath Chakravarthy. "Growing Trend of Alternative Tobacco Use Among the Nation's Youth: A New Generation of Addicts." *Western Journal of Emergency Medicine* 17.2 (2016): 139.
- McCann et al., "Detection of carcinogens as mutagens in the *Salmonella*/microsome test: Assay of 300 chemicals: discussion." *Proct. Nat. Acad. Sci, USA*, Mar. 1976, vol. 73 (3), 950-954.
- Mylaps, "Rechargeable Transponder Battery Status and Charging Instructions," Sep. 9, 2010.
- Nicoli et al., Mammalian tumor xenografts induce neovascularization in Zebrafish embryos. *Cancer Research*, 67:2927-2931 (2007).
- Pax Labs, Inc.; JUUL product information © 2016; retrieved from <https://www.juulvapor.com/shop-juul/>; 6 pgs.; retrieved Mar. 9, 2016.
- Perfetti, "Structural study of nicotine salts," *Beitrage Zur Tabakforschung International, Contributions to Tobacco Research*, 12(2), pp. 43-54. Jun. 1983.
- Polosa, Riccardo, et al. "Effect of an electronic nicotine delivery device (e-Cigarette) on smoking reduction and cessation: a prospective 6-month pilot study." *BMC public health* 11.1 (2011): 786.
- Poynton, Simon, et al. "A novel hybrid tobacco product that delivers a tobacco flavour note with vapour aerosol (part 1): Product operation and preliminary aerosol chemistry assessment." *Food and Chemical Toxicology* (2017).
- Poynton, Simon, et al. "A novel hybrid tobacco product that delivers a tobacco flavour note with vapour aerosol (Part 1): product operation and preliminary aerosol chemistry assessment." *Food and Chemical Toxicology* 106 (2017): 522-532.
- Seeman, et al., "The form of nicotine in tobacco. Thermal transfer of nicotine and nicotine acid salts to nicotine in the gas phase," *J Aric Food Chem*, 47(12), pp. 5133-5145. Dec. 1999.
- Smok. *Pro Color—SMOK® Innovation keeps changing the vaping experience!*, Date Accessed Feb. 20, 2018. www.smoktech.com/kit/procolor.
- SRNT Subcommittee on Biochemical Verification, "Biochemical verification of tobacco use and cessation," *Nicotine & Tobacco Research* 4, pp. 149-159, 2002.
- Tarantola, Andrew. "The Pax 2 vaporizer makes its predecessor look half-Baked." *Engadget*, Jul. 14, 2016, www.engadget.com/2015/04/20/pax-2-vaporizer-review/. Accessed Sep. 5, 2017.
- Torikai et al., "Effects of temperature, atmosphere and pH on the generation of smoke compounds during tobacco pyrolysis," *Food and Chemical Toxicology* 42 (2004) 1409-1417.
- Vansickel, et al. "A clinical laboratory model for evaluating the acute effects of electronic cigarettes: Nicotine delivery profile and cardiovascular and subjective effects," *Cancer Epidemiology Biomarkers Prevention*, 19(9), pp. 1945-1953. Jul. 20, 2010.
- Vansickel, et al., "Electronic cigarettes: effective nicotine delivery after acute administration," *Nicotine & Tobacco Research*, 15(1), pp. 267-270. Jan. 2013.
- VapeWorld; Original PAX Vaporizers for Portable and Home Use; retrieved from: <https://www.vapeworld.com/pax-vaporizer-by-ploom?gclid=CPCi1PKojskCFU06gQodPr>; 9 pgs.; retrieved Nov. 13, 2015.
- Vapresso (Shenzhen Smoore Technology Limited). "Target Pro Vape Mod." *Vape Batteries & Mods | Target Pro Vape Mod | Vapresso*, Date Accessed Feb. 20, 2018. www.vapresso.com/vape-batteries-and-mods/target-pro-vape-mod.
- Vapresso (Shenzhen Smoore Technology Limited). "Tarot Pro Vape Mod." *Vape Batteries & Mods | Tarot Pro Vape Mod | Vapresso*, Date Accessed Feb. 20, 2018. www.vapresso.com/vape-batteries-and-mods/tarot-pro-vape-mod.
- Wells. "Glycerin as a Constituent of Cosmetics and Toilet Preparations." *Journal of the Society of Cosmetic Chemists*, 1958; 9(1): 19-25.
- Williams, Monique, and Prue Talbot. "Variability among electronic cigarettes in the pressure drop, airflow rate, and aerosol production." *Nicotine & Tobacco Research* 13.12 (2011).
- Youtube, "Pax 2 Unboxing," retrieved from www.youtube.com/watch?v=Vjccs8co3YY, posted Apr. 20, 2015.
- YouTube; Firefly Vaporizer Review w/ Usage Tips by the Vape Critic; retrieved from the internet (<http://www.youtube.com/watch?v=1J38N0AV7wl>); published Dec. 10, 2013; download/ print date: Feb. 18, 2015.
- Youtube; Pax by Ploom Vaporizer Review; posted Aug. 14, 2013, retrieved Sep. 8, 2016, <https://www.youtube.com/watch?v=Jm06zW3-cxQ>.
- Zhang, et al., "In vitro partical size distributions in electronic and conventional cigarette aerosols suggest comparable deposition patterns," *Nicotine Tobacco Research*, 15(2), pp. 501-508. Feb. 2013.
- Pierce, D. *This Might Just Be the First Great E-Cig*. [online] *Wired*, published on Apr. 21, 2015. Available at: https://www.wired.com/2015/04/pax-juul-ecig/?mbid=social_twitter.

The Verge. *Startup behind the Lambo of vaporizers just launched an intelligent e-cigarette*. [online], published on Apr. 21, 2015. Available at: <https://www.theverge.com/2015/4/21/8458629/pax-labs-e-cigarette-juul>.

Engadget. *Juul is the e-cig that will finally stop me from smoking (I hope)*. [online], published on Jun. 3, 2015. Available at: <https://www.engadget.com/2015/06/03/pax-labs-juul-e-cigarette/#/>.

* cited by examiner

Primary Examiner — Michael A. Pratt

(74) *Attorney, Agent, or Firm* — Mintz Levin Cohn Ferris Glovsky and Popeo, P.C.

(57) **CLAIM**

The ornamental design for a vaporizer cartridge, as shown and described.

DESCRIPTION

1.1 is a right side, front, and top perspective view of a vaporizer cartridge showing a first embodiment of our design;

1.2 is a bottom, front, and right side perspective view thereof;

1.3 is a front view thereof, the rear view thereof being identical;

1.4 is a left side view thereof, the right side view thereof being identical;

1.5 is bottom view thereof; and

1.6 is a top view thereof.

2.1 is a right side, front, and top perspective view of a vaporizer cartridge showing a second embodiment of our design;

2.2 is a bottom, front, and right side perspective view thereof;

2.3 is a front view thereof, the rear view thereof being identical;

2.4 is a left side view thereof, the right side view thereof being identical;

2.5 is bottom view thereof; and

2.6 is a top view thereof.

3.1 is a right side, front, and top perspective view of a vaporizer cartridge showing a third embodiment of our design;

3.2 is a bottom, front, and right side perspective view thereof;

3.3 is a front view thereof, the rear view thereof being identical;

3.4 is a left side view thereof, the right side view thereof being identical;

3.5 is bottom view thereof; and

3.6 is a top view thereof.

4.1 is a right side, front, and top perspective view of a vaporizer cartridge showing a fourth embodiment of our design;

4.2 is a bottom, front, and right side perspective view thereof;

4.3 is a front view thereof;

4.4 is a left side view thereof;

4.5 is bottom view thereof; and,

4.6 is a top view thereof.

1 Claim, 24 Drawing Sheets

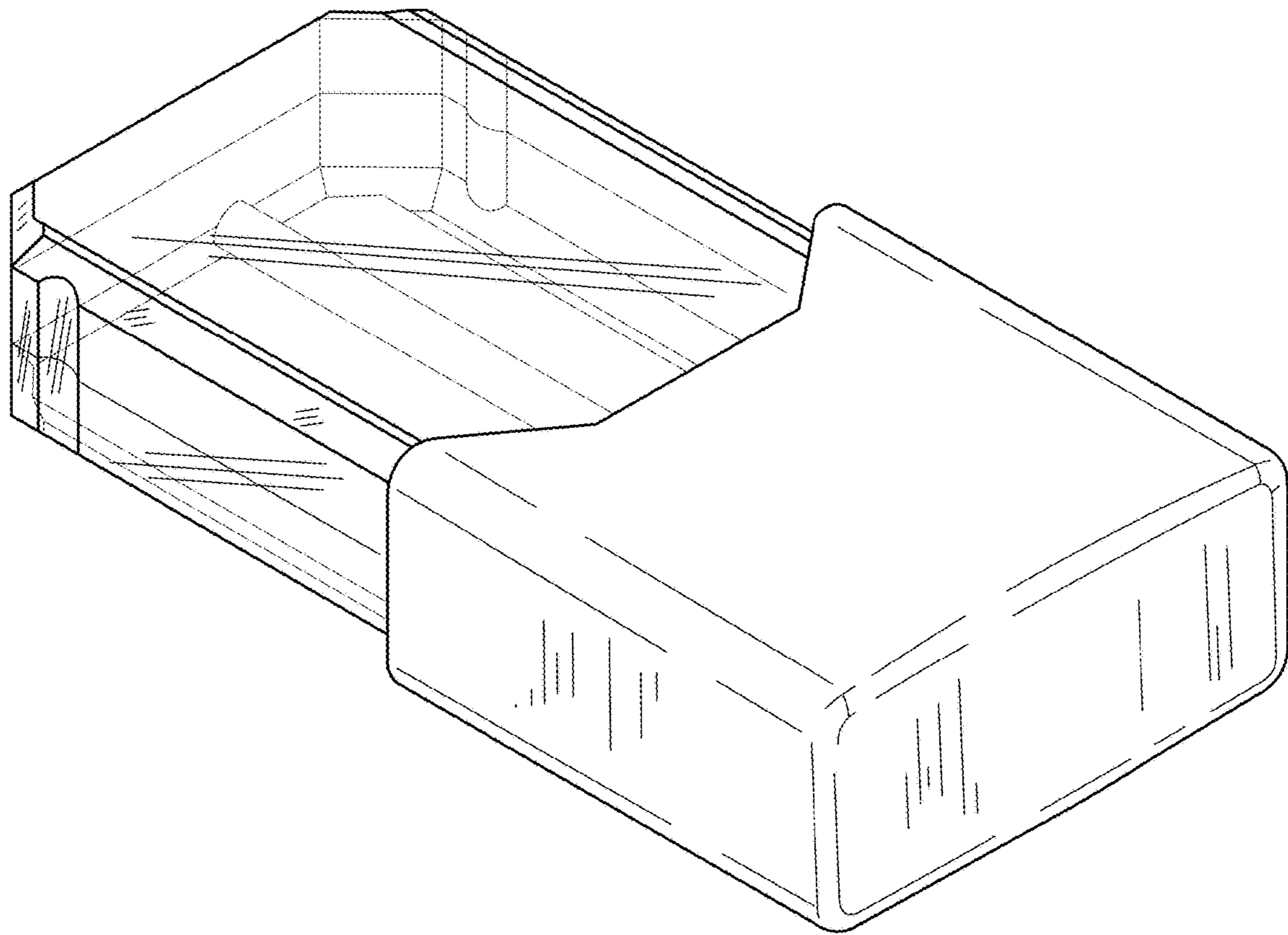

1.1

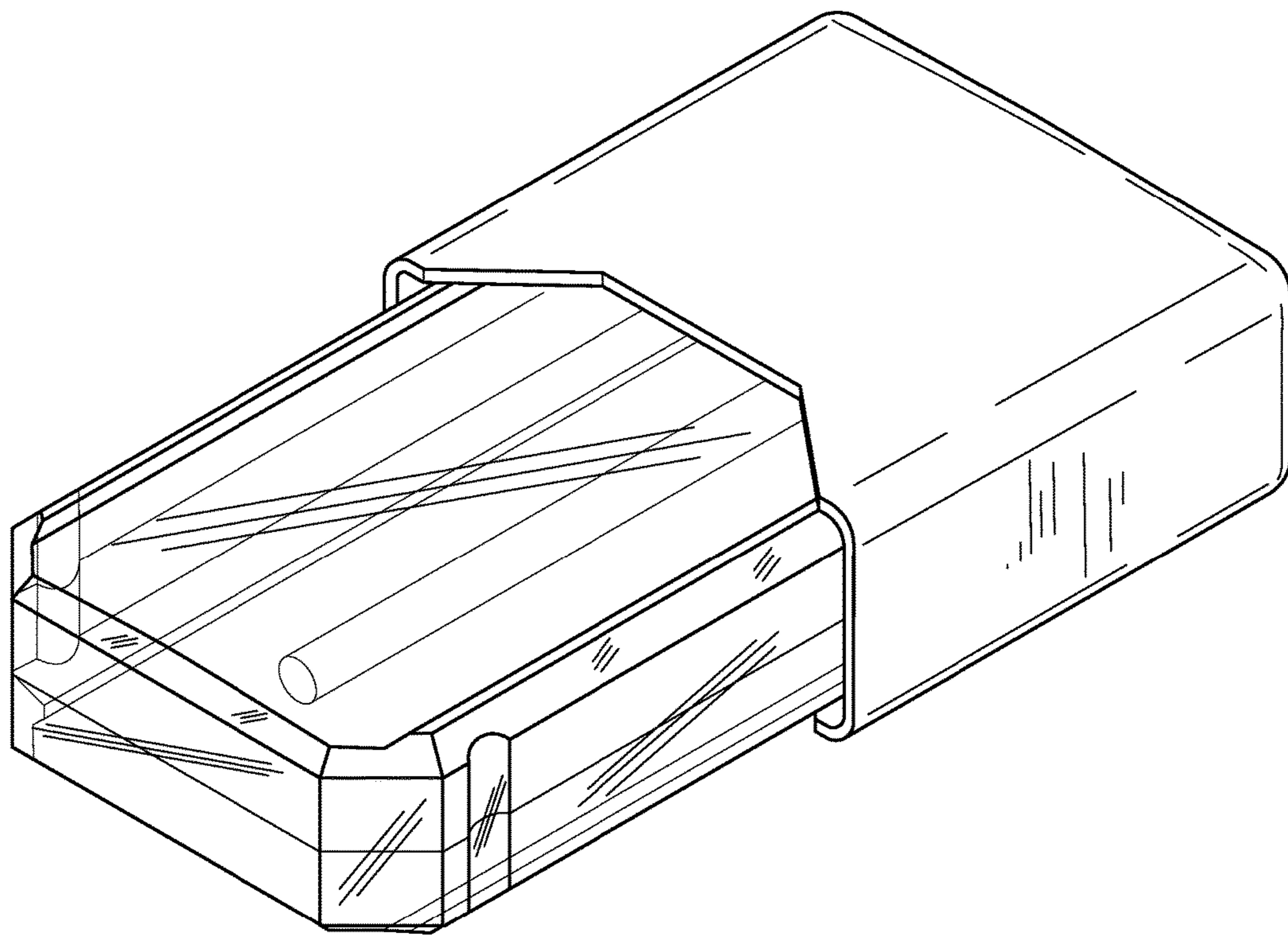

1.2

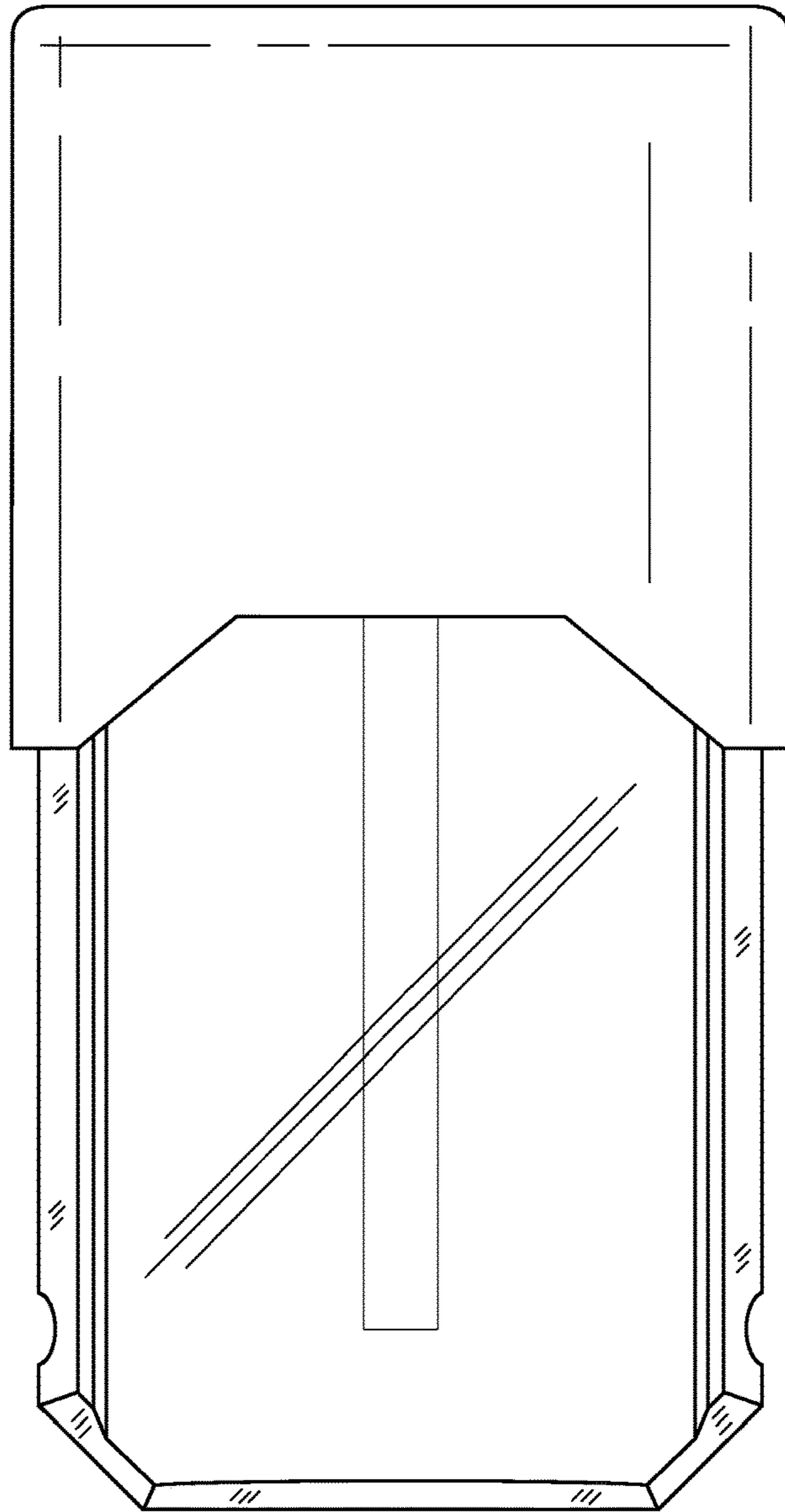

1.3

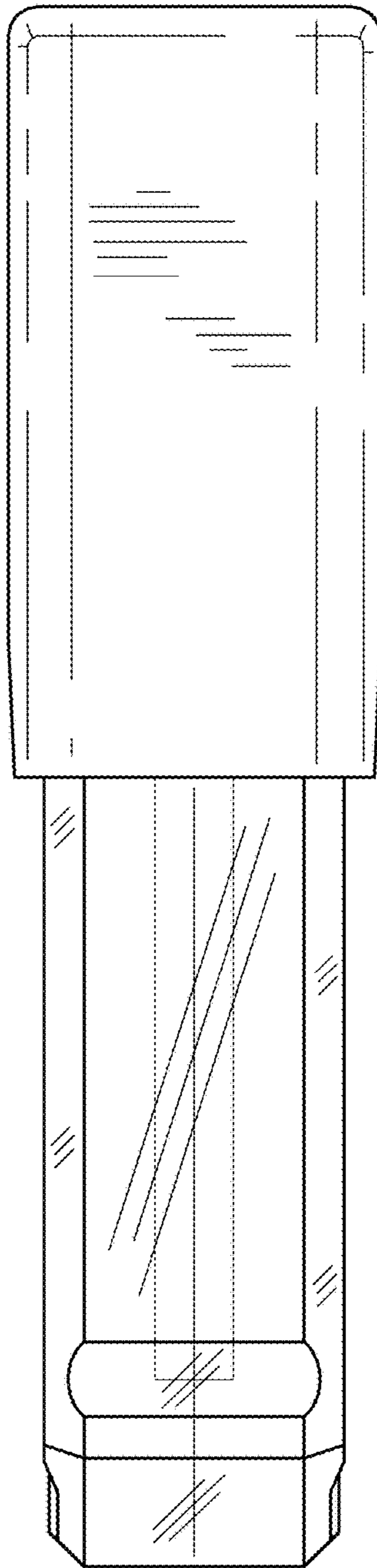

1.4

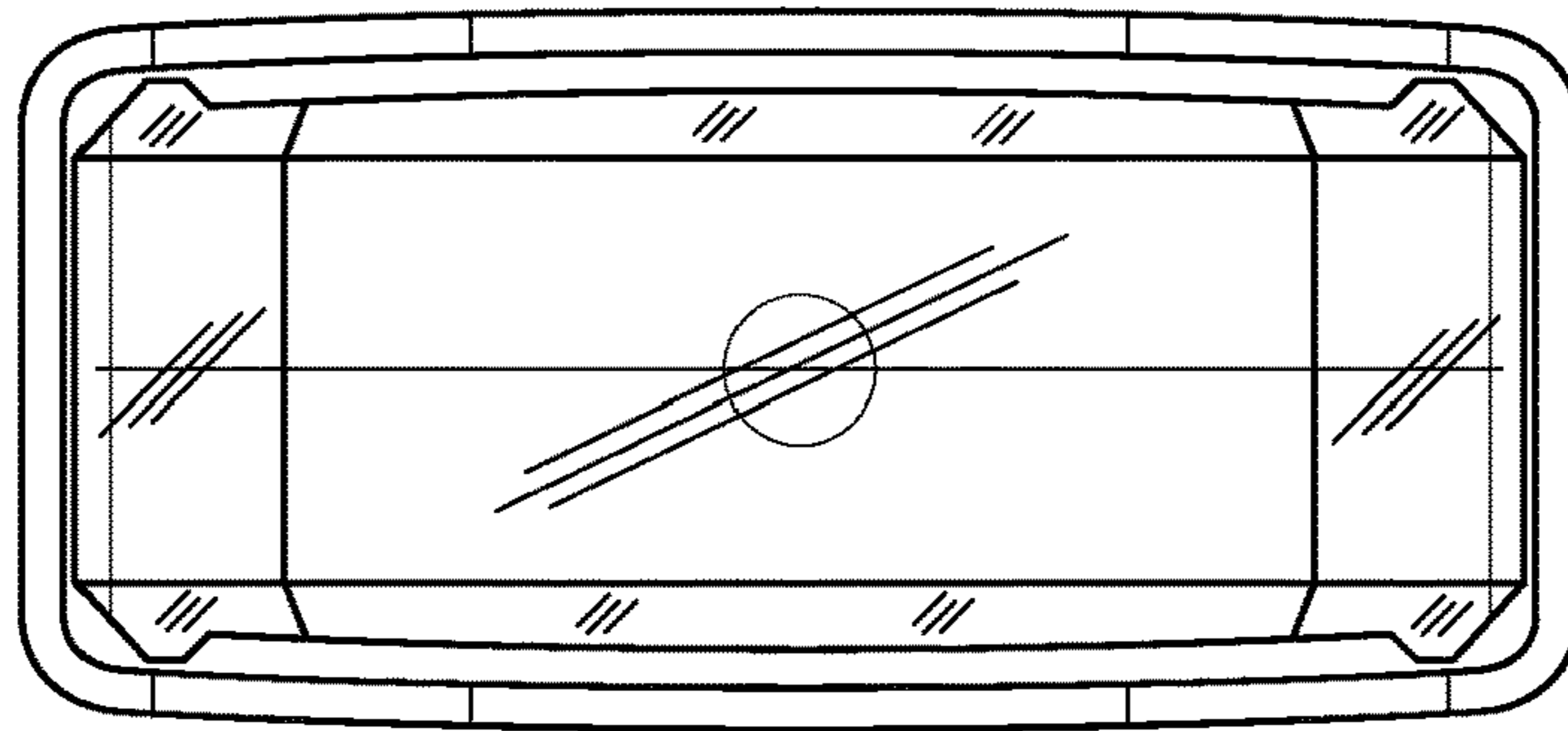

1.5

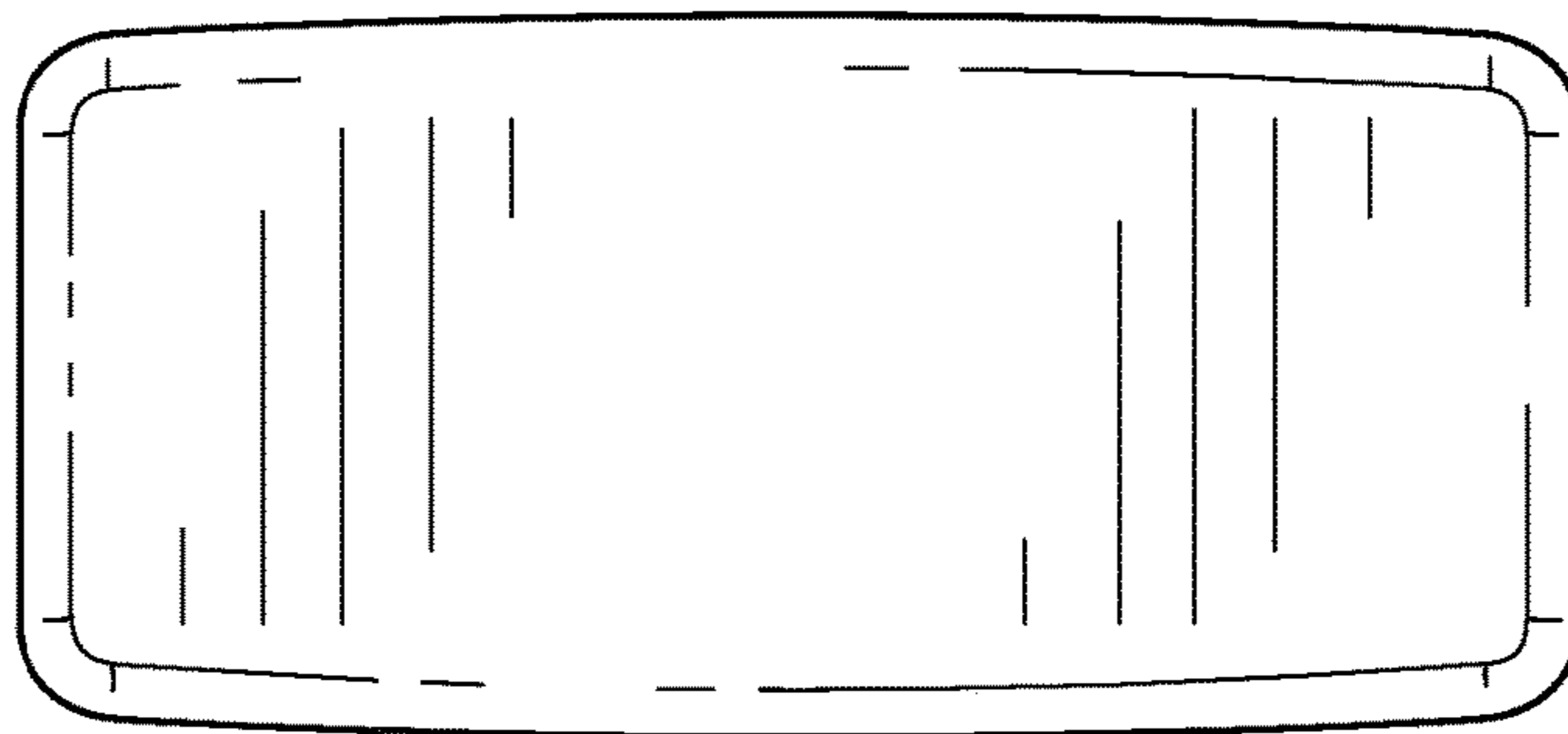

1.6

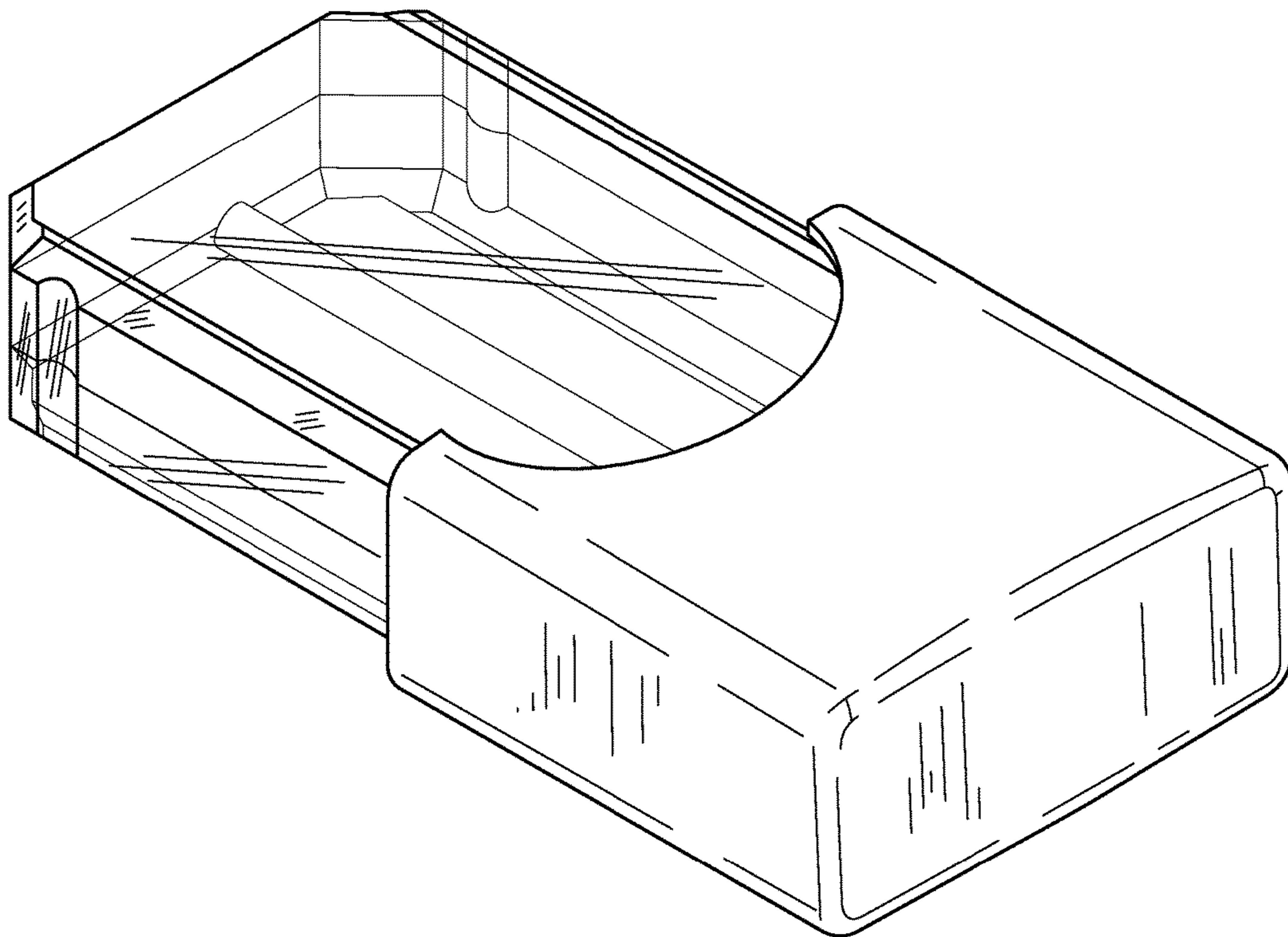

2.1

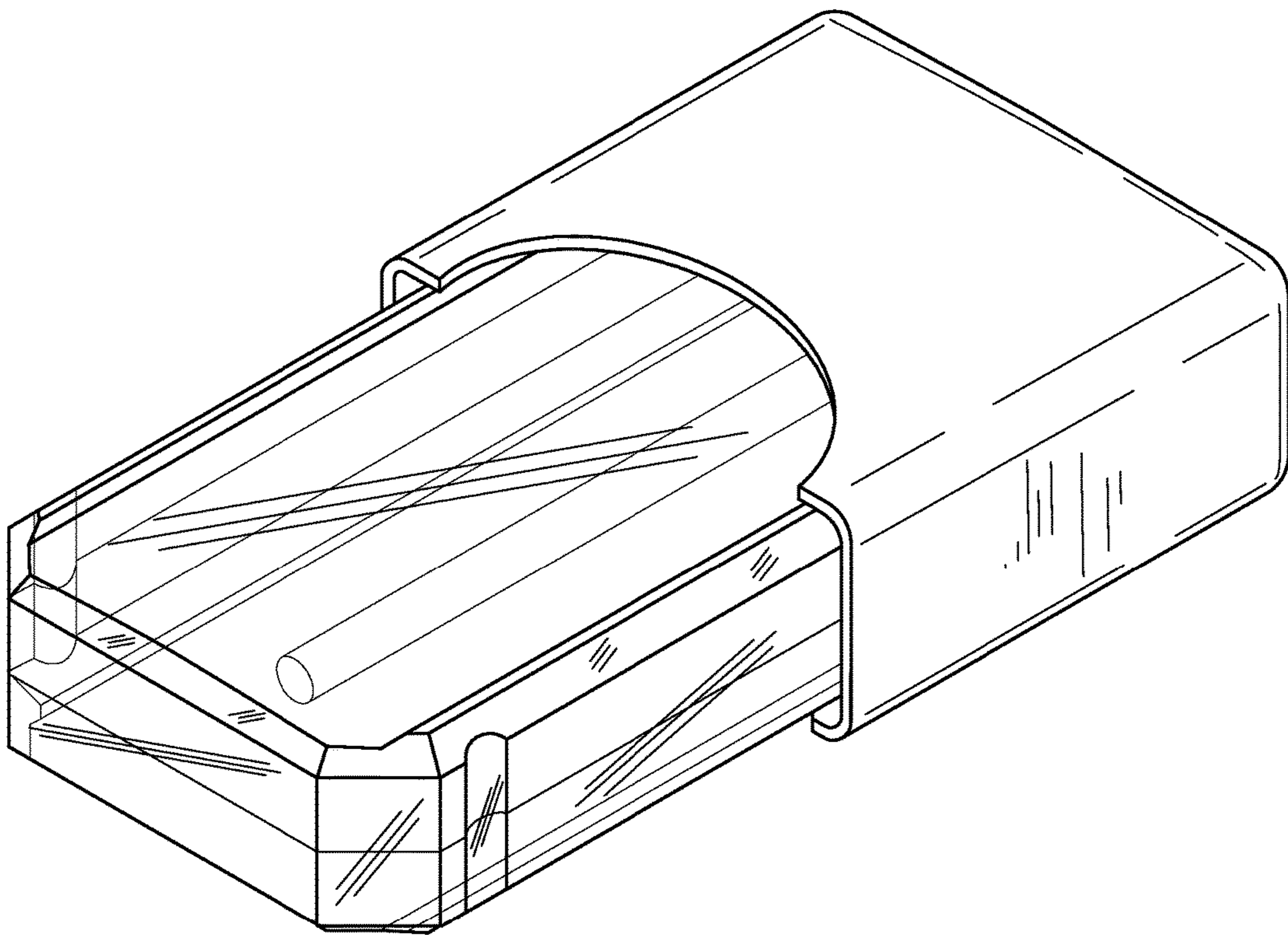

2.2

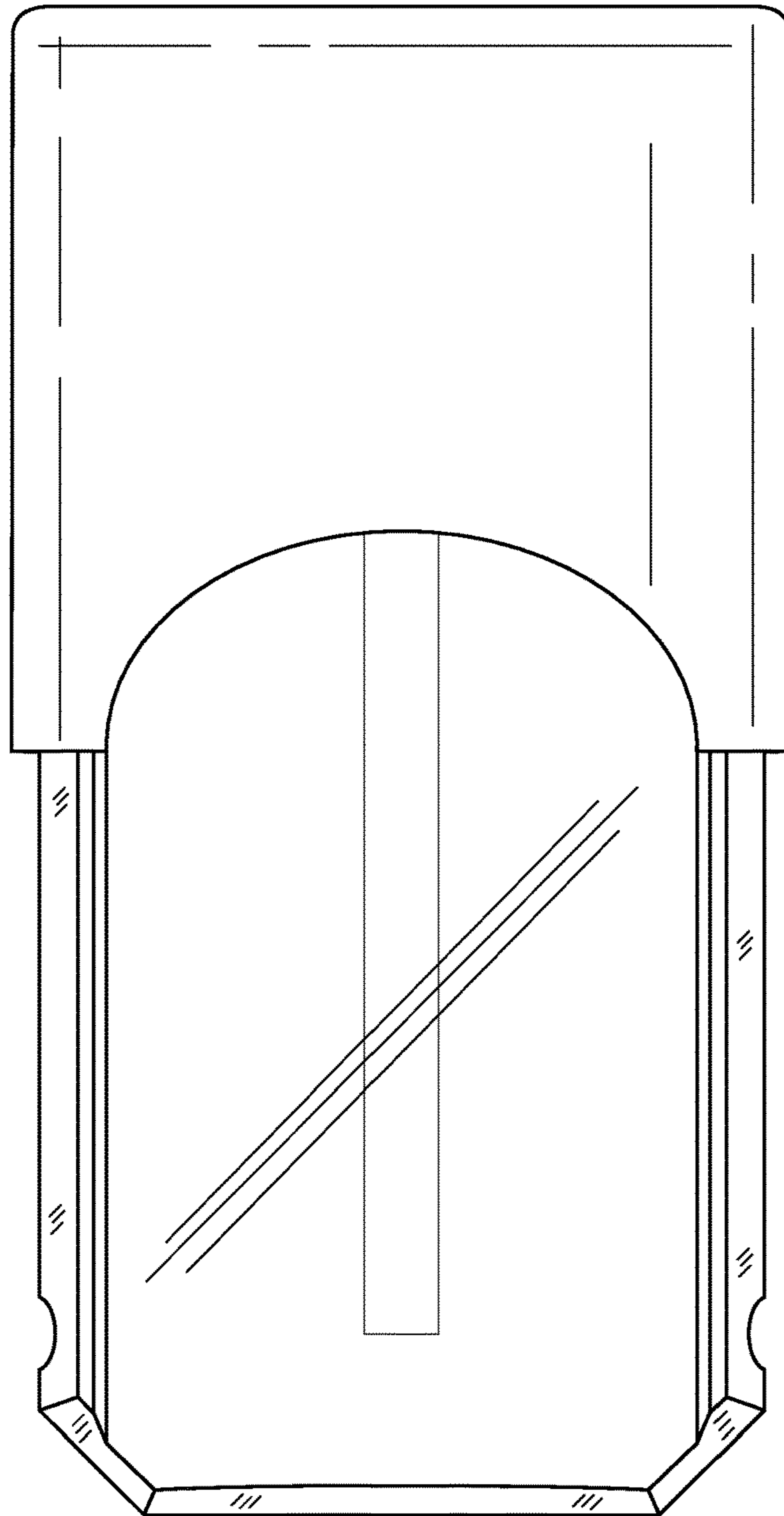

2.3

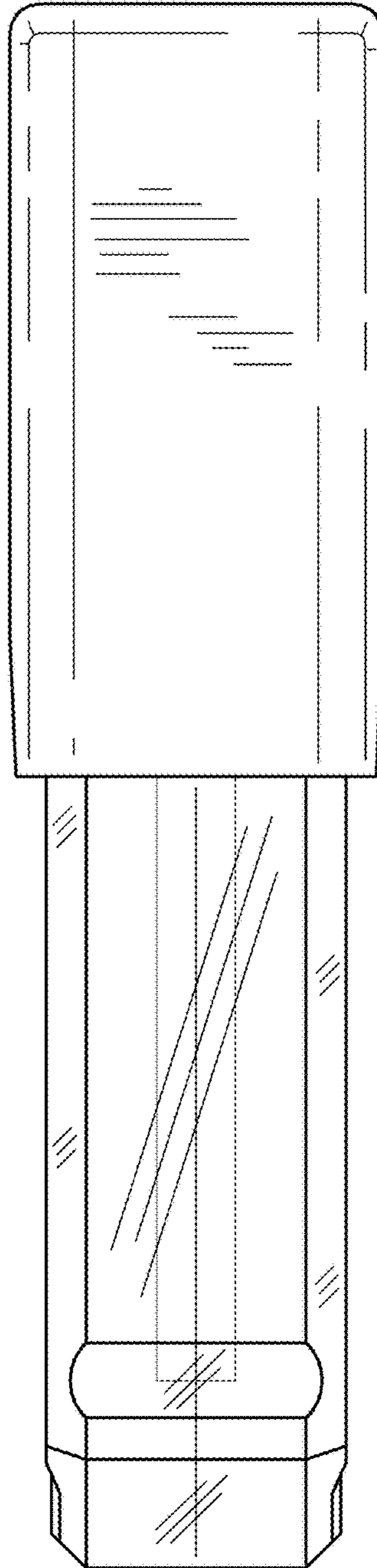

2.4

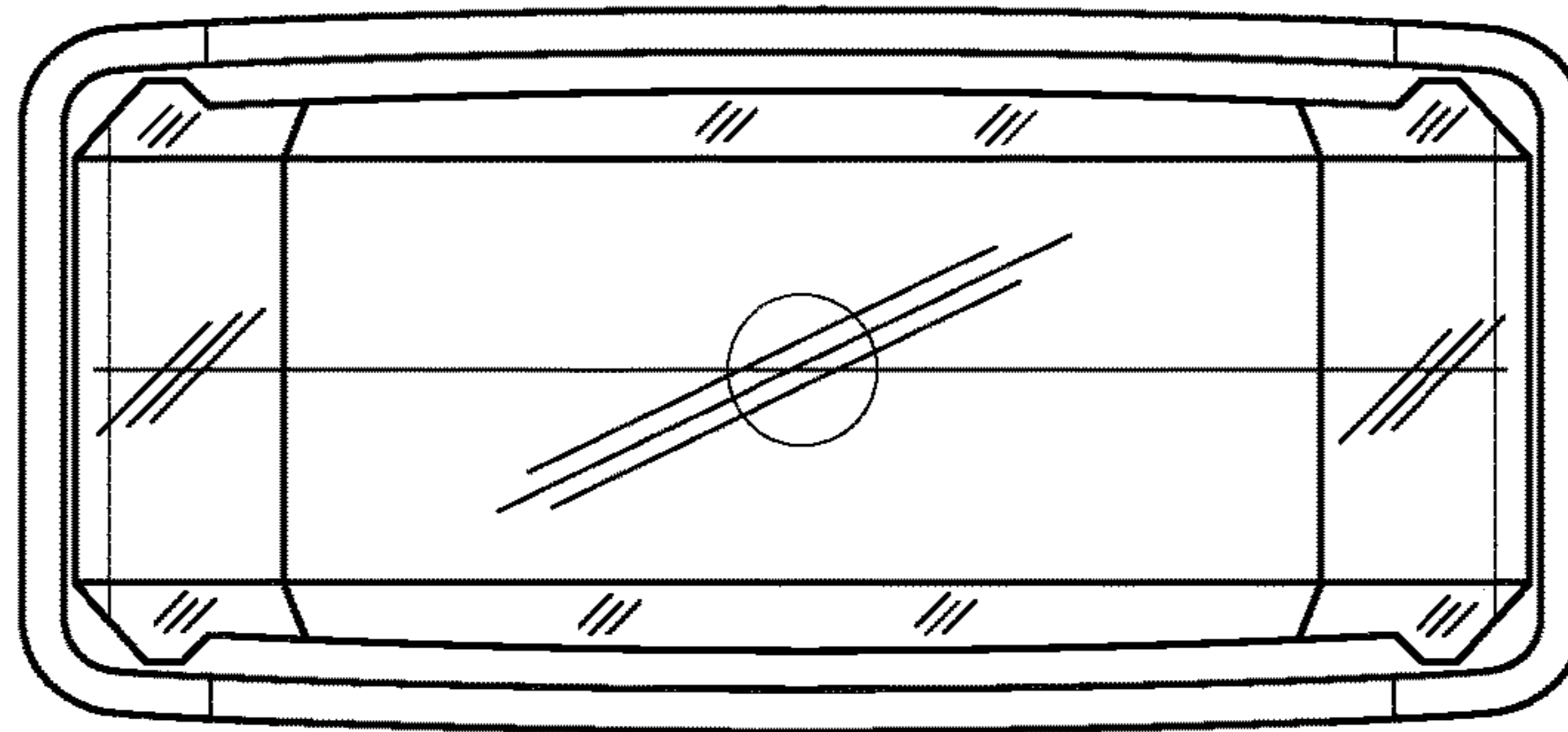

2.5

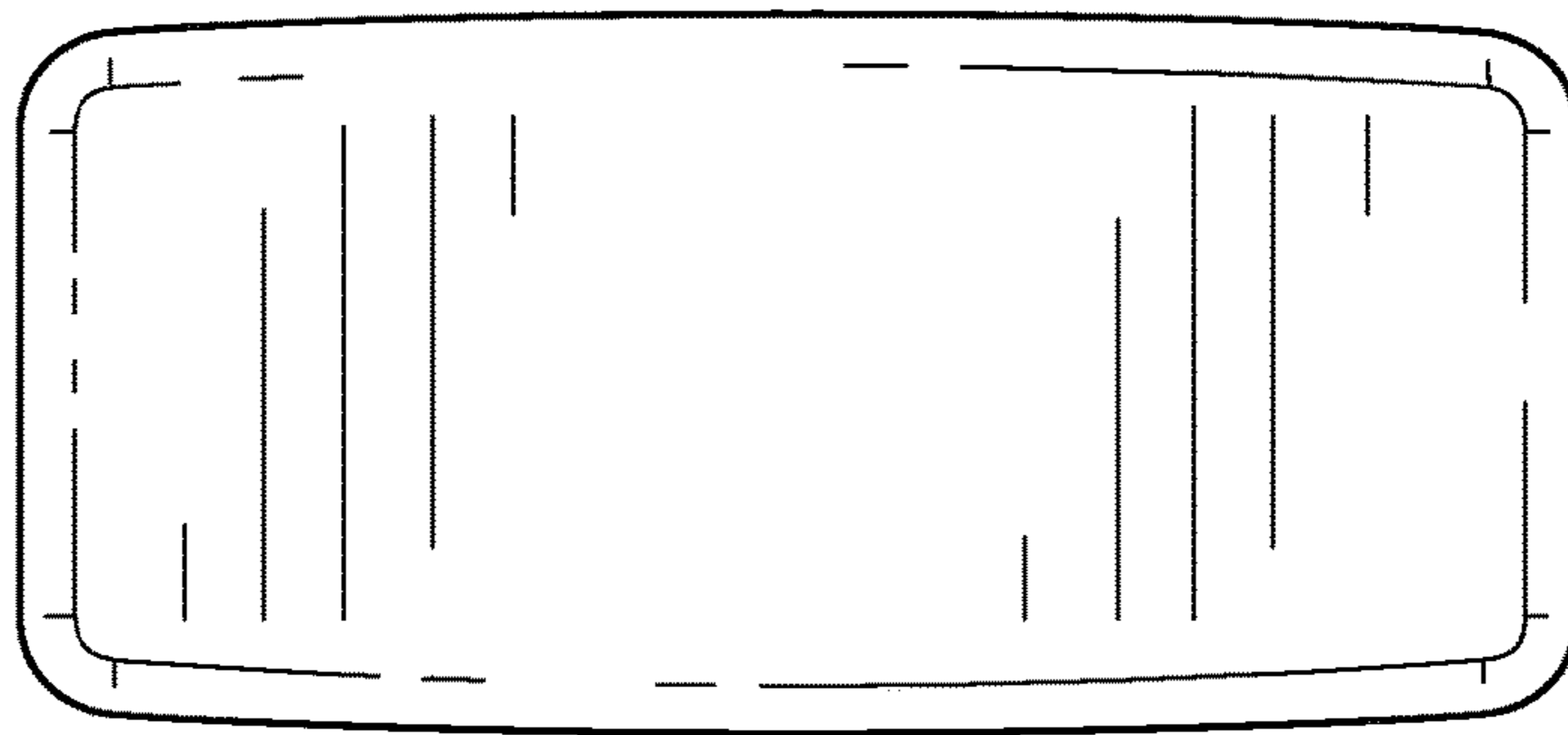

2.6

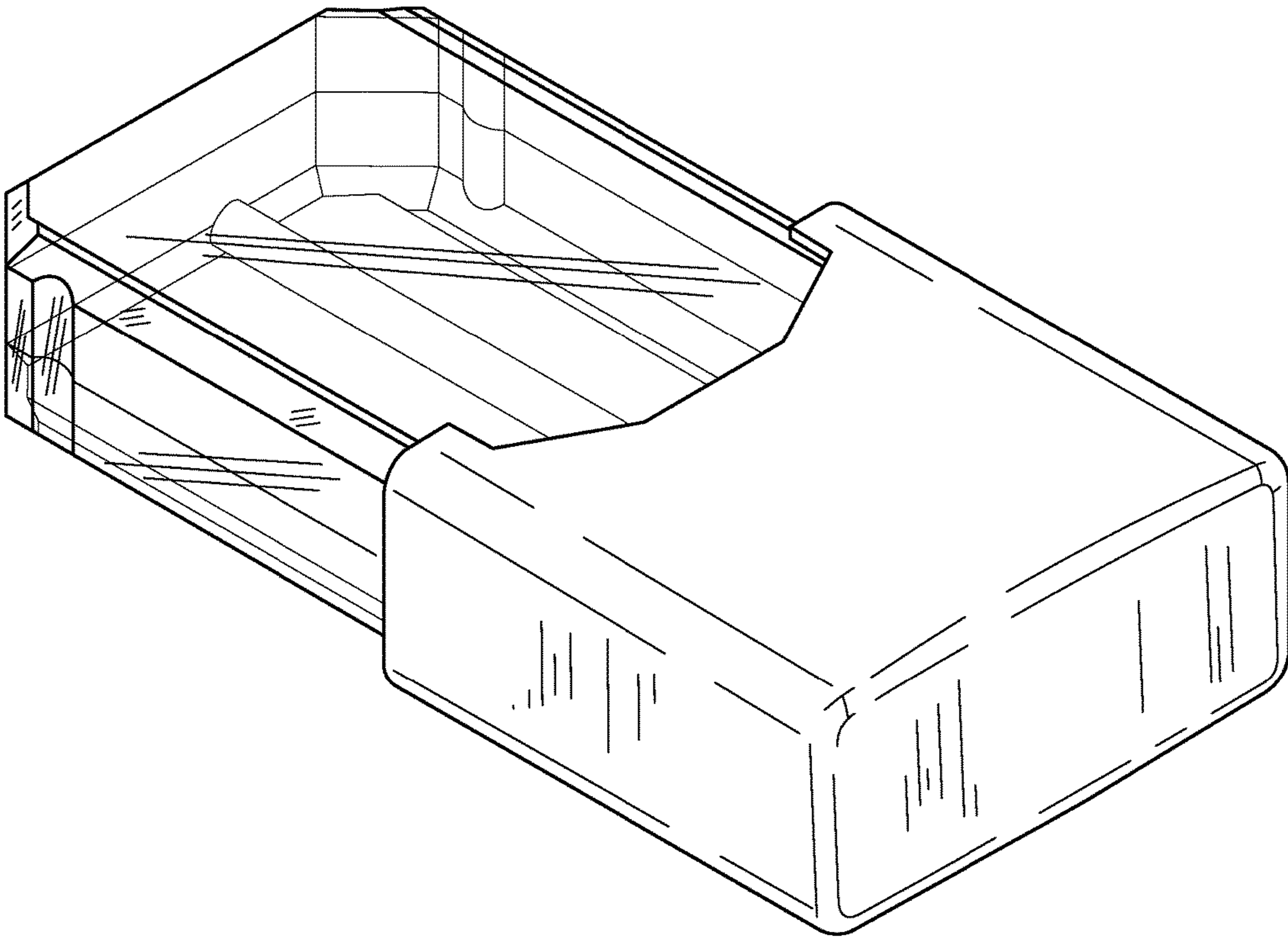

3.1

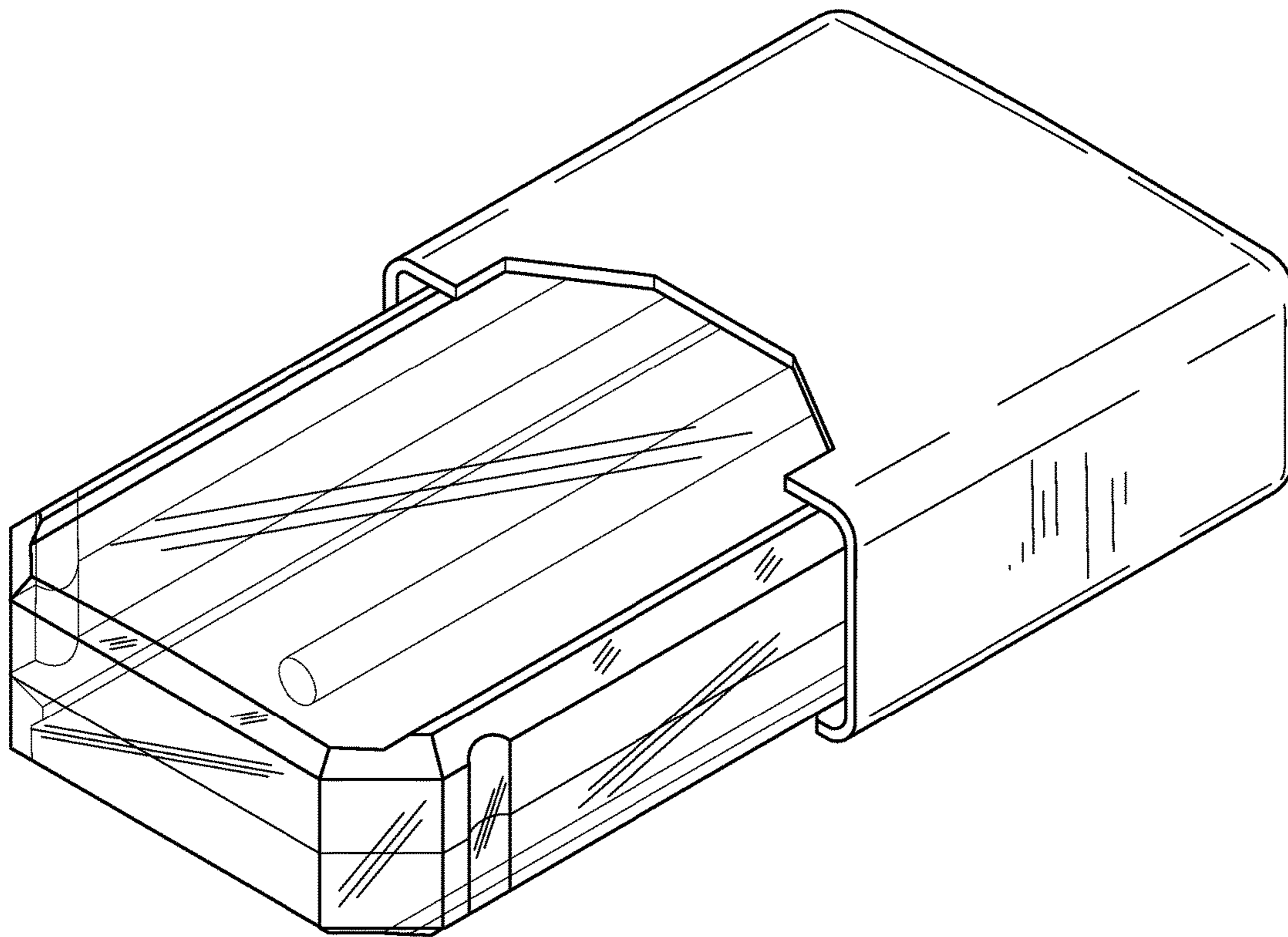

3.2

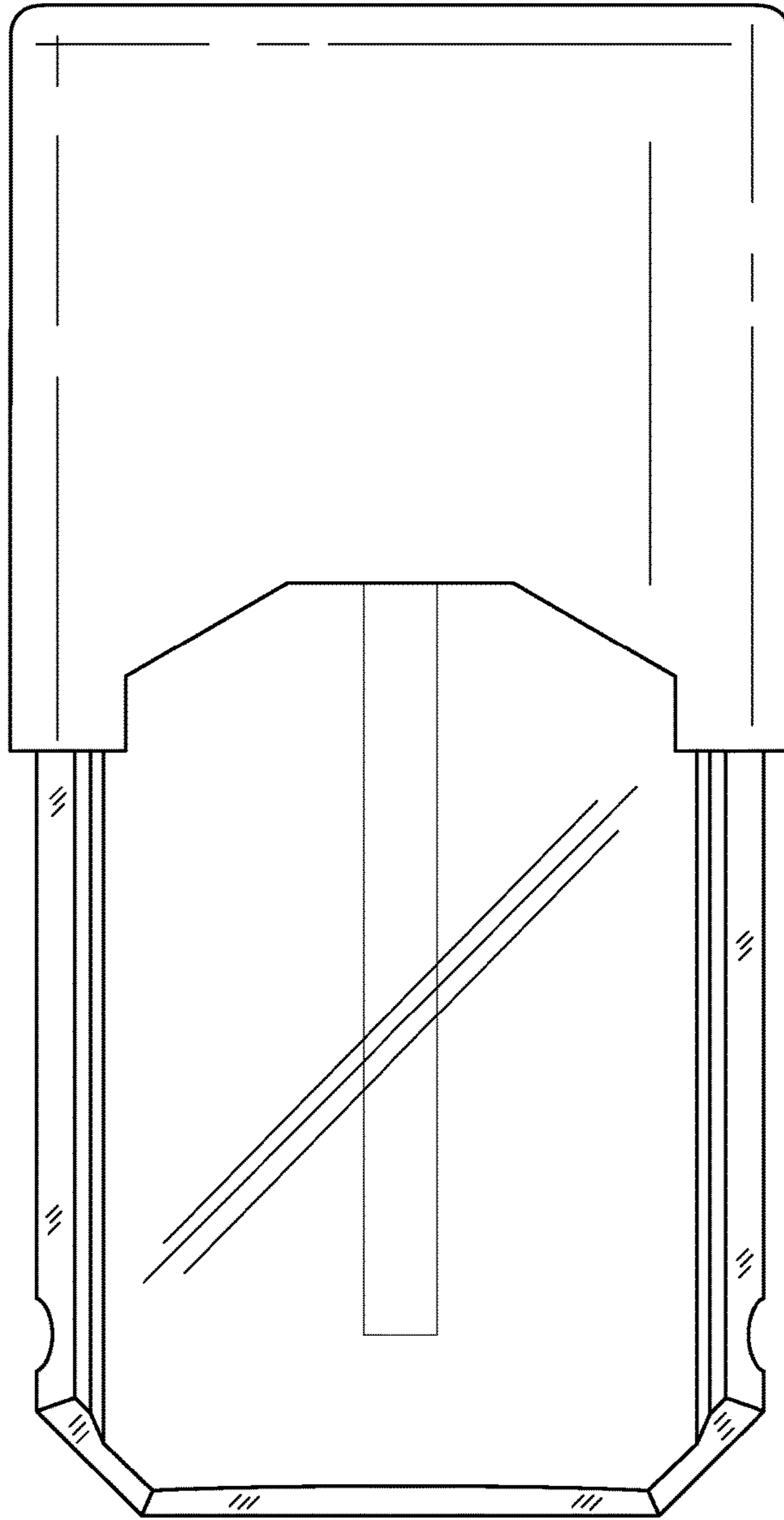

3.3

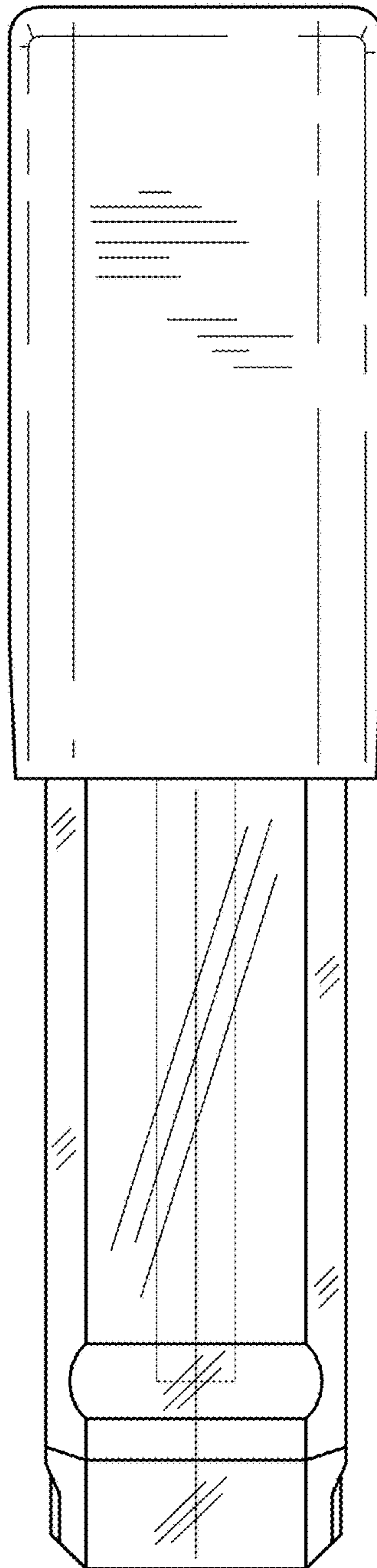

3.4

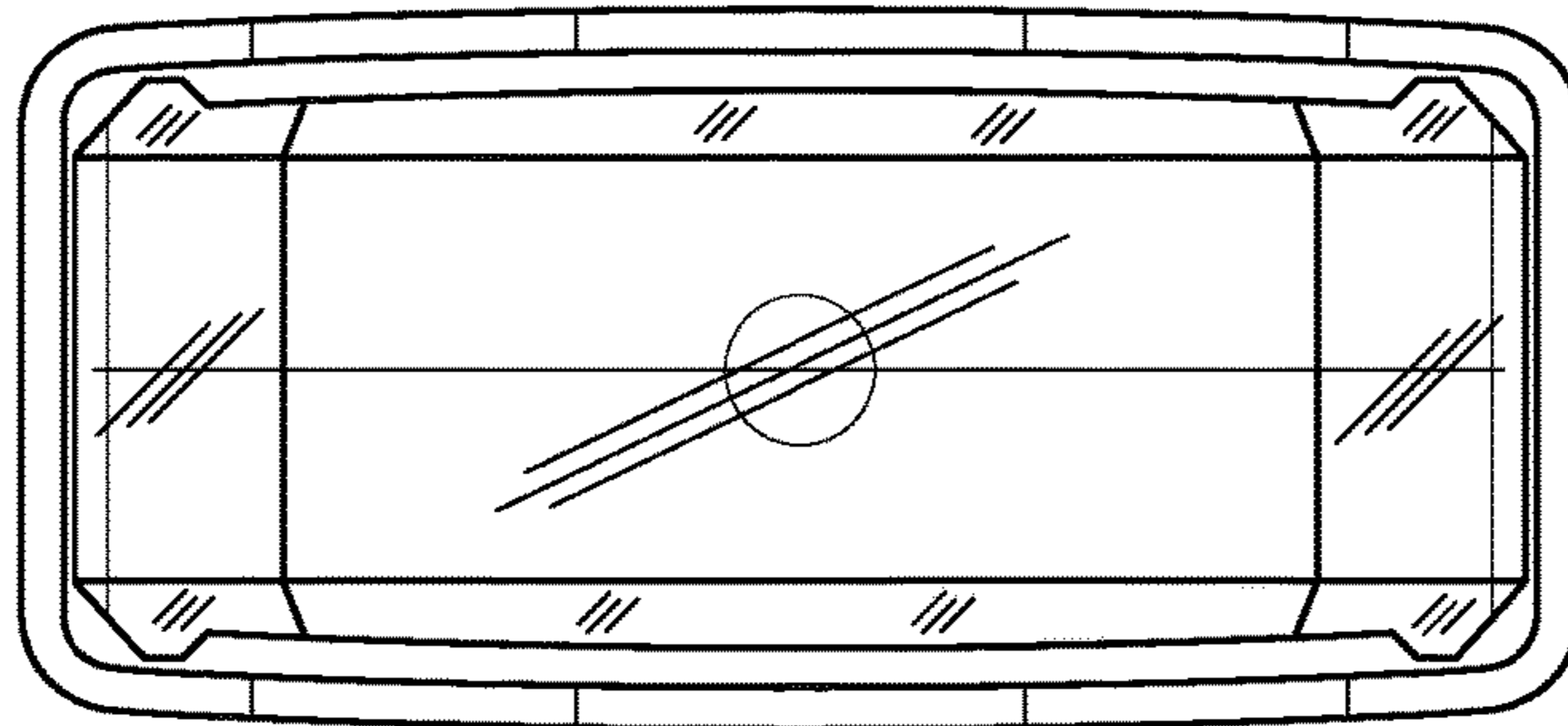

3.5

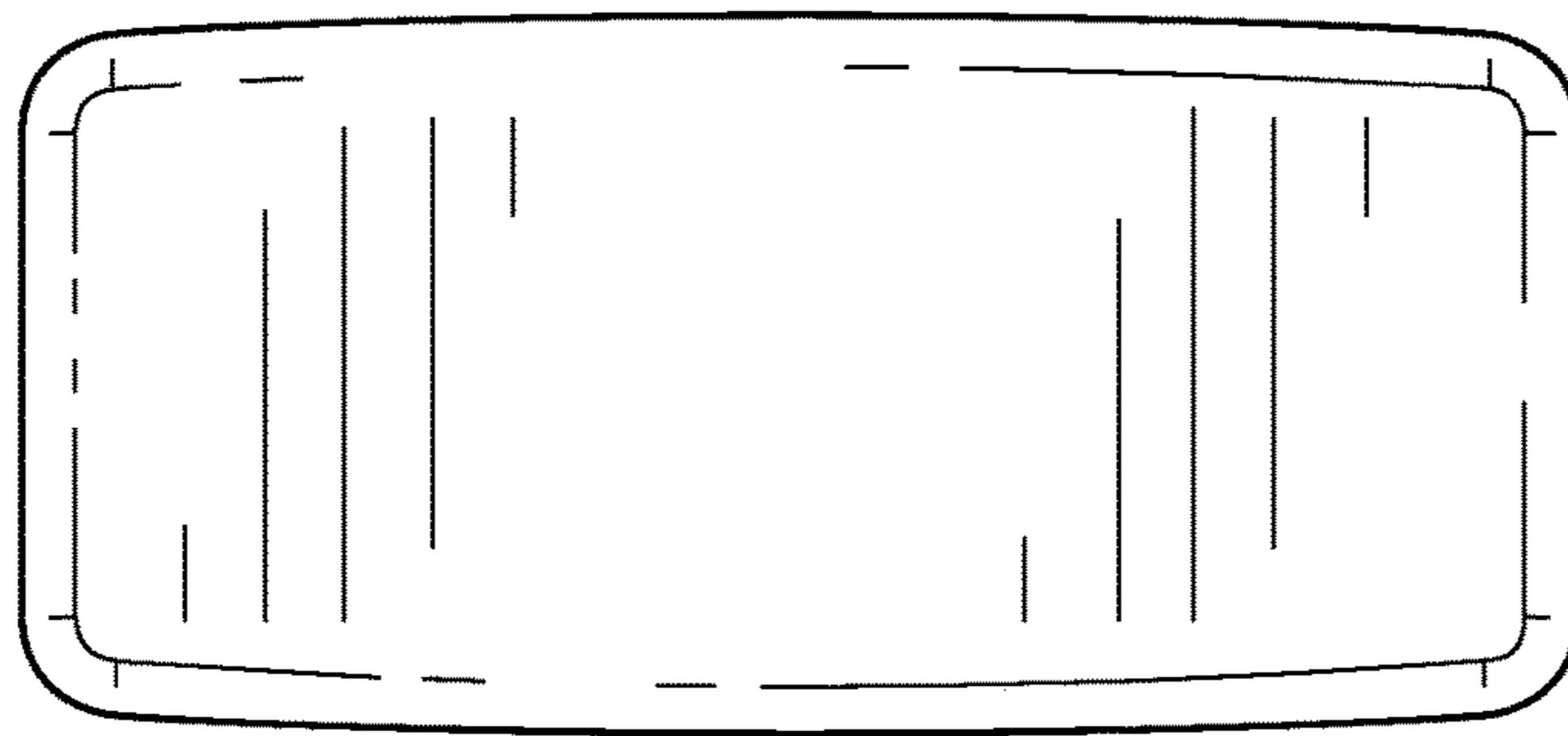

3.6

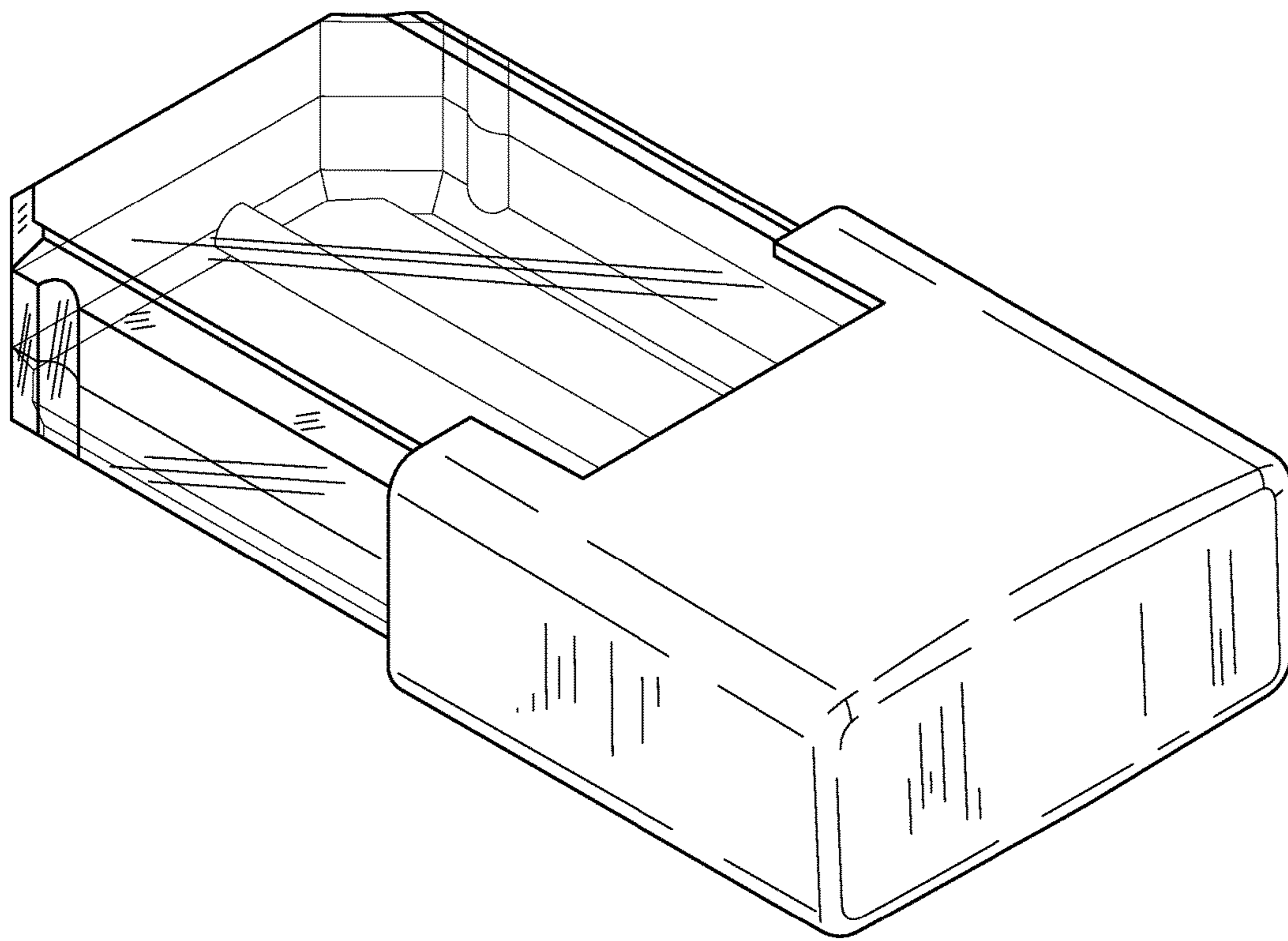

4.1

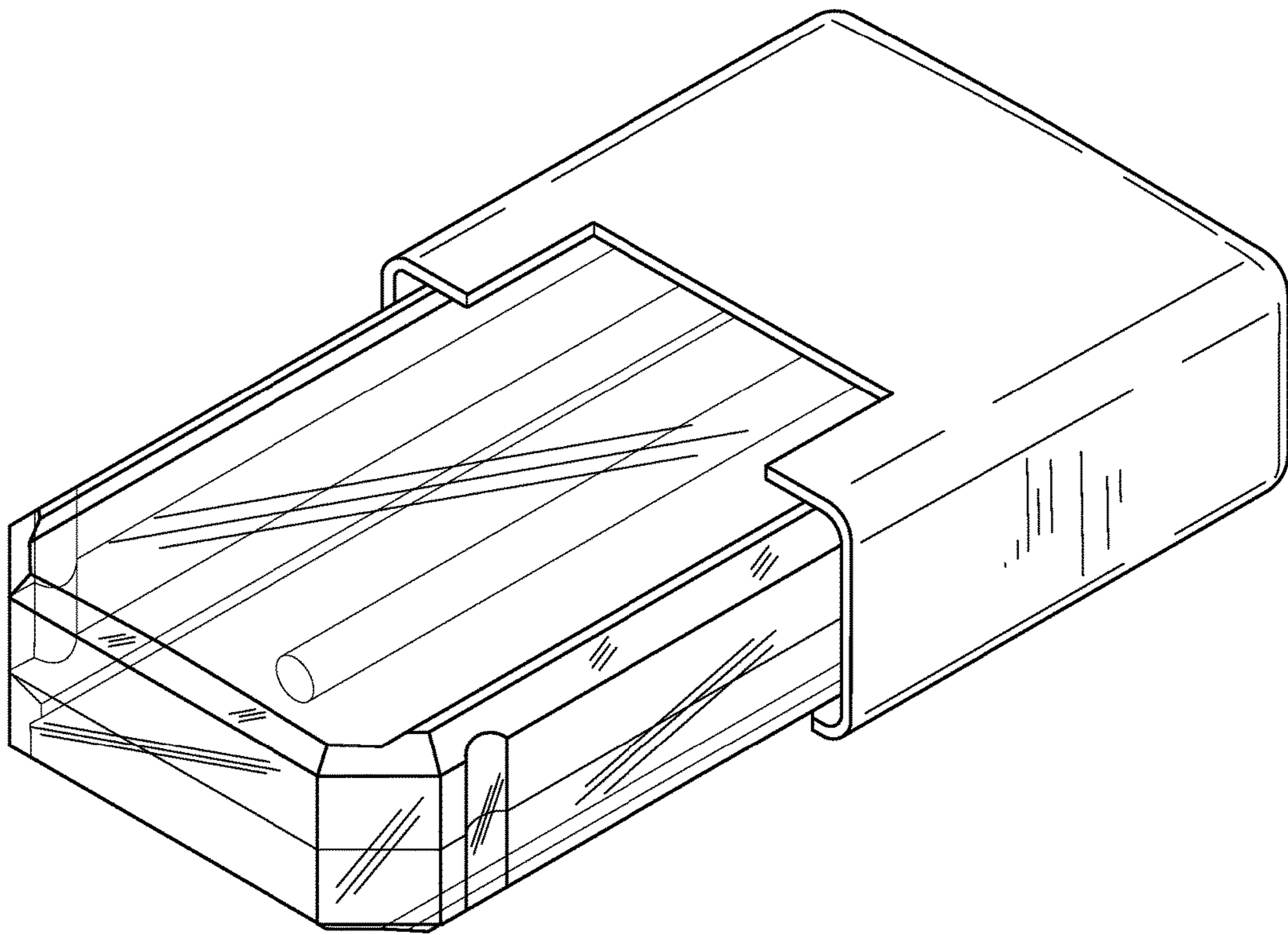

4.2

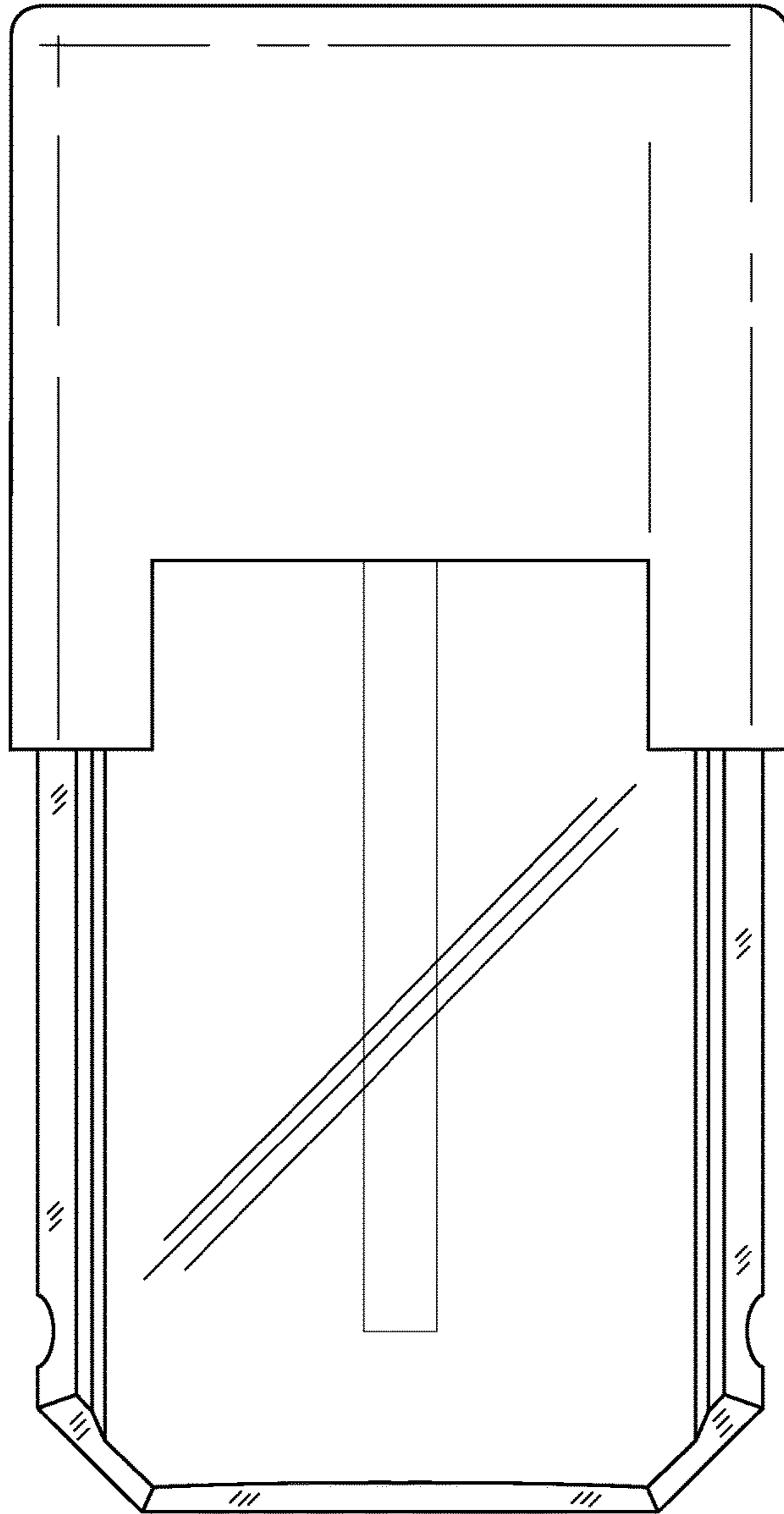

4.3

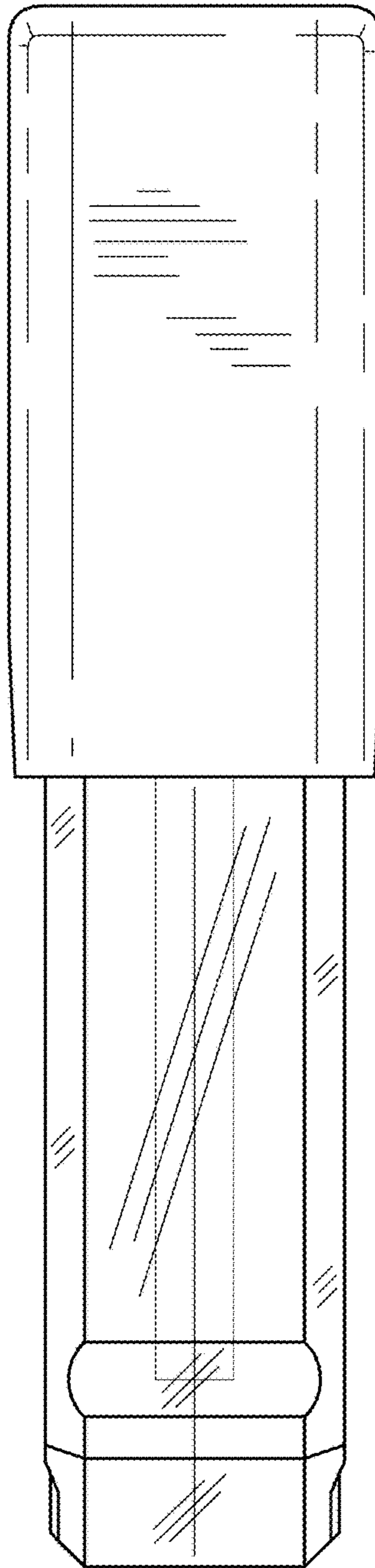

4.4

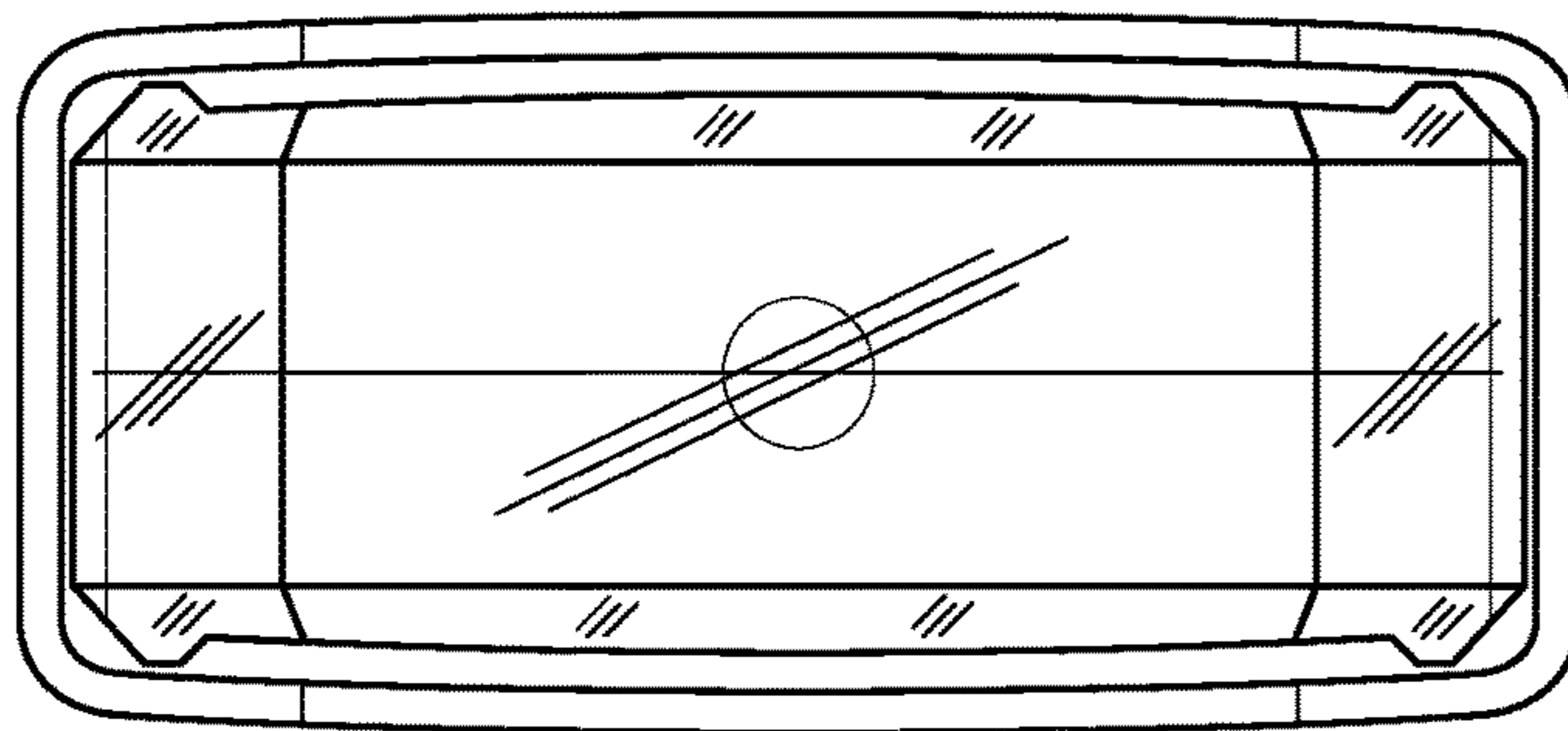

4.5

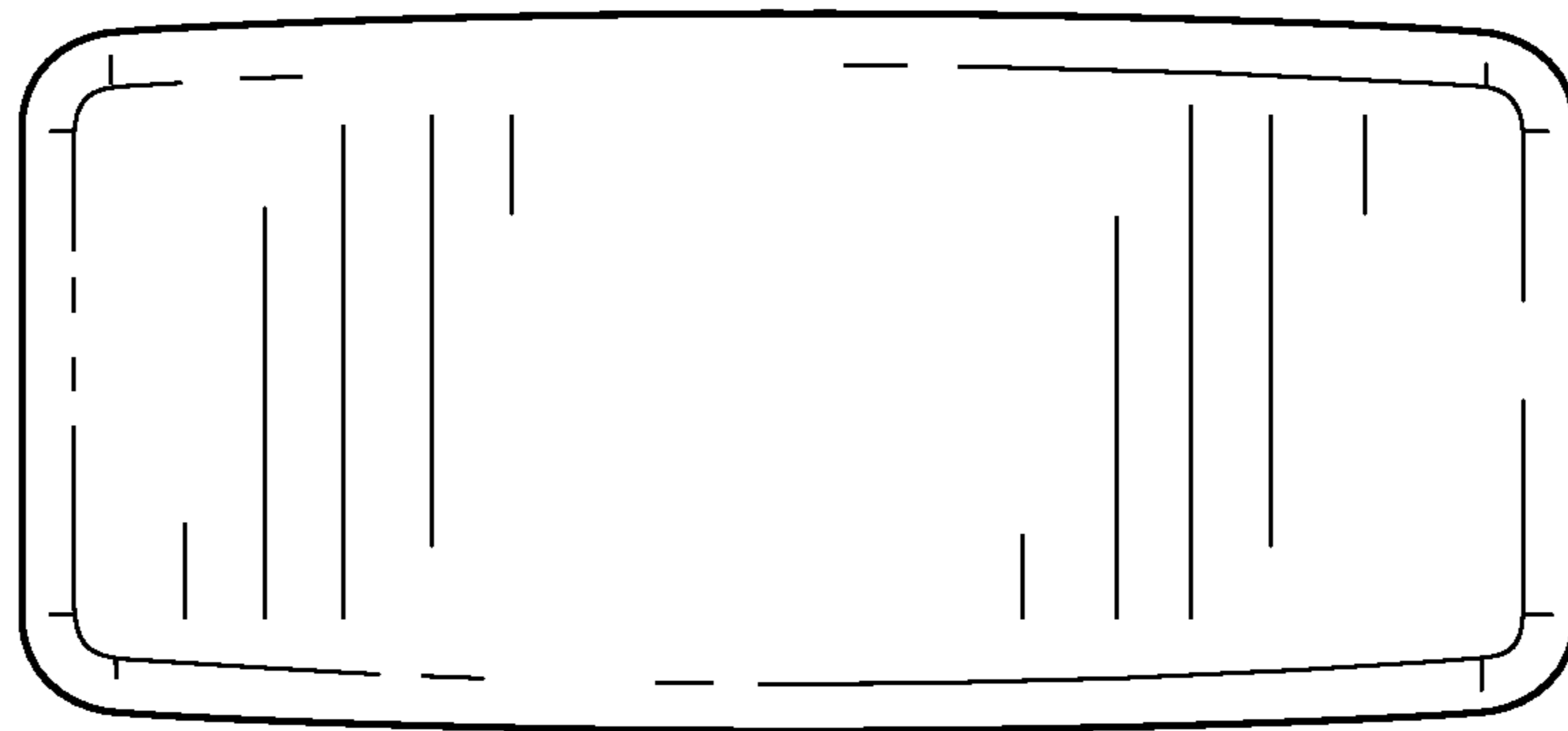

4.6

UNITED STATES PATENT AND TRADEMARK OFFICE
CERTIFICATE OF CORRECTION

PATENT NO. : D842,536 S
APPLICATION NO. : 35/001170
DATED : March 5, 2019
INVENTOR(S) : Adam Bowen et al.

Page 1 of 1

It is certified that error appears in the above-identified patent and that said Letters Patent is hereby corrected as shown below:

On the Title Page

Item (30), at Column 1, please add:

Foreign Application Priority Data

Chinese Application No. 201630043696.6, filed on February 8, 2016.

Signed and Sealed this
Twelfth Day of May, 2020

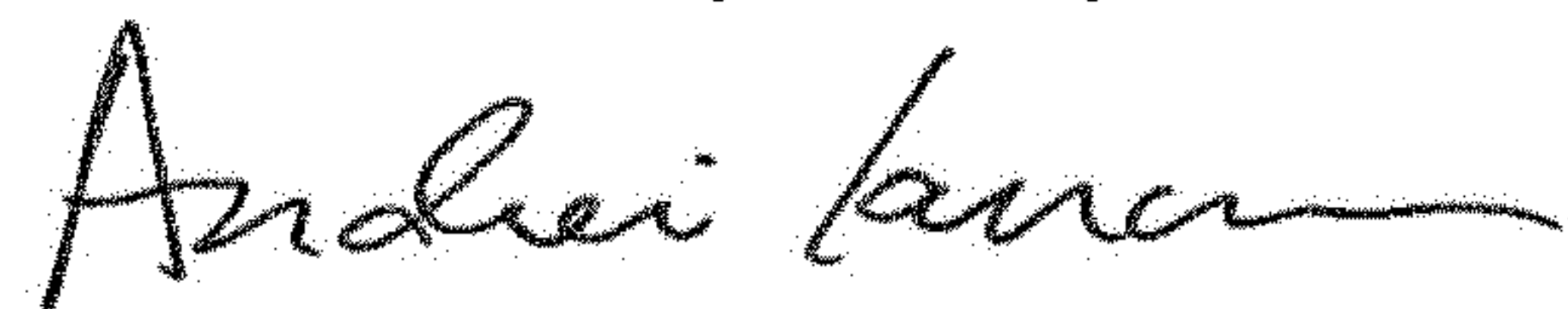

Andrei Iancu
Director of the United States Patent and Trademark Office