



US00D842086S

(12) **United States Design Patent**
Vandenberg

(10) **Patent No.:** **US D842,086 S**
(45) **Date of Patent:** **** Mar. 5, 2019**

- (54) **SCREW**
- (71) Applicant: **National Nail Corp.**, Grand Rapids, MI (US)
- (72) Inventor: **Roger A. Vandenberg**, Hudsonville, MI (US)
- (73) Assignee: **National Nail Corp.**, Grand Rapids, MI (US)
- (**) Term: **15 Years**
- (21) Appl. No.: **29/638,273**
- (22) Filed: **Feb. 26, 2018**
- (51) **LOC (11) Cl.** **08-08**
- (52) **U.S. Cl.**
USPC **D8/387**
- (58) **Field of Classification Search**
USPC D8/387, 382, 385, 388, 391, 393, 349, D8/354, 383, 499
CPC F16B 13/00; F16B 13/124; F16B 23/00; F16B 23/0015; F16B 23/0023; F16B 23/003; F16B 23/0038; F16B 23/0046; F16B 23/0061; F16B 25/0036; F16B 25/0052; F16B 25/0057; F16B 25/0063; F16B 25/103; F16B 25/106; F16B 33/02; F16B 35/04; F16B 35/06; F16B 35/041; F16B 35/048
See application file for complete search history.

- 2,994,878 A 8/1961 Abrahamsen
- 3,010,496 A 11/1961 Bruce
- 3,012,247 A 12/1961 Sillars
- 3,147,484 A 9/1964 Nelson
- 3,177,755 A 4/1965 Kahn
- (Continued)

FOREIGN PATENT DOCUMENTS

- CA 1242601 10/1988
- CH 695482 6/2006
- (Continued)

OTHER PUBLICATIONS

- Fiberon DeckPilot 3/09.
- (Continued)

Primary Examiner — Sandra S Snapp
Assistant Examiner — Ieisha N Price
 (74) *Attorney, Agent, or Firm* — Warner Norcross + Judd, LLP

(57) **CLAIM**

The ornamental design for screw, as shown and described.

DESCRIPTION

FIG. 1 is a first perspective view of the screw embodying the new design;
 FIG. 2 is a second perspective view thereof;
 FIG. 3 is a left side view thereof;
 FIG. 4 is a right side view thereof;
 FIG. 5 is a point end view thereof; and,
 FIG. 6 is a head end view thereof.
 FIGS. 1-6 show features of a screw in broken lines. These features do not form any part of the claimed design. The broken lines immediately adjacent the solid-line portions of the design form the boundary of the design, with the broken lines forming no part of the claimed design.

1 Claim, 3 Drawing Sheets

- (56) **References Cited**
U.S. PATENT DOCUMENTS
- 126,366 A 4/1872 Wills
- 137,414 A 4/1873 Burdick
- 138,784 A 5/1873 Bourn
- 411,202 A 9/1889 Rose
- 877,831 A 1/1908 Creedon
- 984,323 A 2/1911 Vauclain
- 2,774,969 A 12/1956 Samples

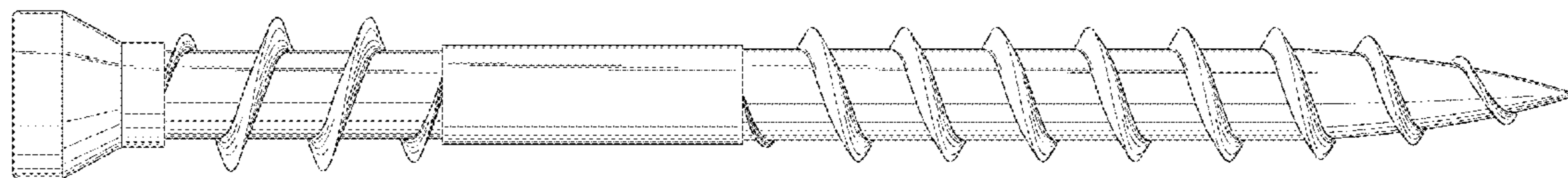

(56)

References Cited

U.S. PATENT DOCUMENTS

3,207,023 A	9/1965	Knohl	6,769,332 B2	8/2004	Muro
3,316,949 A	5/1967	Canfield	6,843,402 B2	1/2005	Sims et al.
3,357,295 A	12/1967	Smith	6,887,023 B1	5/2005	Lu et al.
3,360,176 A	12/1967	Gehl	6,915,724 B2	7/2005	Kigel et al.
3,738,218 A	6/1973	Gutshall	6,941,635 B2	9/2005	Craven
3,942,405 A	3/1976	Wagner	6,941,847 B2	9/2005	Habermehl et al.
4,018,254 A	4/1977	DeCaro	7,037,059 B2	5/2006	Dicke
4,068,554 A	1/1978	Hirabayashi	7,044,460 B2	5/2006	Bolton
4,123,186 A	10/1978	Hoadley	7,090,453 B2	8/2006	Lin
4,146,071 A	3/1979	Mueller et al.	7,156,600 B2	1/2007	Panasik et al.
4,209,275 A	6/1980	Kim	7,165,481 B2	1/2007	Kikuchi
4,241,638 A	12/1980	Shimizu et al.	7,231,854 B2	6/2007	Kikuchi
4,323,326 A	4/1982	Okada et al.	D557,130 S	12/2007	Kashikura et al.
4,329,099 A	5/1982	Shimizu et al.	D557,131 S	12/2007	Liu
4,439,077 A	3/1984	Godsted	7,344,057 B2	3/2008	Dion et al.
4,572,720 A	2/1986	Rockenfeller et al.	D567,644 S	4/2008	Liu
4,586,862 A	5/1986	Yamasaki	7,424,840 B1	9/2008	Huang
4,625,597 A	12/1986	Cast	7,454,996 B2	11/2008	Hsu
4,653,244 A *	3/1987	Farrell E04F 13/0837	D581,776 S	12/2008	Yin-Feng
		411/399	7,487,699 B2	2/2009	Xu
4,834,602 A	5/1989	Takasaki	D604,153 S	11/2009	Wantz
5,015,134 A *	5/1991	Gotoh F16B 25/0015	7,682,118 B2	3/2010	Gong et al.
		411/386	7,682,119 B2	3/2010	Chen
5,064,324 A	11/1991	Ragaller	7,695,228 B2	4/2010	Craven
5,083,483 A	1/1992	Takagi	D614,942 S	5/2010	Gaudron
5,188,496 A	2/1993	Giannuzzi	7,866,236 B2	1/2011	Hsu
5,217,339 A *	6/1993	O'Connor E04D 3/3603	RE42,207 E	3/2011	Janusz
		411/161	D634,186 S	3/2011	Kemper
5,282,708 A	2/1994	Giannuzzi	D637,071 S	5/2011	Gaudron et al.
5,322,396 A	6/1994	Blacker	D637,896 S	5/2011	Dotsey
5,337,635 A	8/1994	Habermehl	7,950,312 B2	5/2011	Matthiesen et al.
5,341,706 A	8/1994	Takagi	7,992,469 B2	8/2011	Chang et al.
5,351,586 A	10/1994	Habermehl et al.	D647,393 S	10/2011	Carrillo et al.
5,452,630 A	9/1995	Haas et al.	8,162,196 B2	4/2012	Gasser et al.
5,469,767 A	11/1995	Habermehl	8,192,124 B2	6/2012	Wolpert et al.
5,531,142 A	7/1996	Adamo	D662,808 S *	7/2012	Vandenberg B25B 23/00
5,531,143 A	7/1996	Habermehl et al.			D8/387
5,568,753 A	10/1996	Habermehl et al.	8,348,571 B2	1/2013	Shih
5,570,618 A	11/1996	Habermehl et al.	8,360,702 B2	1/2013	Yu
5,687,624 A	11/1997	Tsuge et al.	8,382,414 B2	2/2013	Vandenberg
D391,135 S	2/1998	Habermehl et al.	D677,147 S	3/2013	Vandenberg
5,839,332 A	11/1998	Fujiyama et al.	8,480,343 B2	7/2013	Vandenberg
5,871,486 A	2/1999	Huebner et al.	D708,509 S *	7/2014	Lin D8/387
5,884,541 A	3/1999	Habermehl et al.	D708,510 S *	7/2014	Lin D8/387
5,904,079 A	5/1999	Tsuge et al.	9,695,860 B2 *	7/2017	Pieciak, Jr. F16B 25/0015
5,918,512 A	7/1999	Habermehl et al.	2003/0235483 A1 *	12/2003	Chen F16B 25/0015
5,927,163 A	7/1999	Habermehl et al.			411/387.7
5,934,162 A	8/1999	Habermehl	2004/0141827 A1	7/2004	Dicke
5,988,025 A	11/1999	Sasaki et al.	2005/0265806 A1	12/2005	Craven
6,022,177 A *	2/2000	Hofer F16B 5/0275	2005/0278934 A1	12/2005	Orchard
		411/399	2007/0128001 A1 *	6/2007	Su F16B 5/0275
6,027,004 A	2/2000	Ramella et al.			411/413
6,089,132 A	7/2000	Habermehl	2007/0217887 A1	9/2007	Lin
6,098,442 A	8/2000	Walldorf et al.	2008/0025816 A1	1/2008	Chen et al.
6,109,144 A	8/2000	Muro	2008/0031705 A1 *	2/2008	Severns F16B 5/0275
6,109,146 A	8/2000	Muro			411/413
6,158,939 A	12/2000	Grossberndt et al.	2008/0080951 A1	4/2008	Lin
6,244,140 B1	6/2001	Habermehl	2008/0264218 A1	10/2008	Wang et al.
6,296,433 B1	10/2001	Forsell et al.	2008/0276761 A1	11/2008	Hale et al.
6,322,307 B1	11/2001	Glover	2008/0296341 A1	12/2008	Francescon
6,328,516 B1	12/2001	Hettich	2009/0142159 A1	6/2009	Wolpert et al.
6,332,741 B1	12/2001	Janusz	2009/0245972 A1 *	10/2009	Lin F16B 5/0275
6,345,940 B2	2/2002	Anjanappa et al.			411/411
6,394,712 B1	5/2002	Weinstein et al.	2009/0314143 A1	12/2009	Chen
6,425,306 B1	7/2002	Habermehl	2010/0083610 A1	4/2010	King
6,439,085 B1	8/2002	Habermehl	2011/0167757 A1	7/2011	Vandenberg
6,453,780 B2	9/2002	Habermehl	2011/0170985 A1 *	7/2011	Vandenberg F16B 25/0015
6,481,937 B1	11/2002	Sommerfeld et al.			411/393
D469,007 S *	1/2003	Chen D8/387	2011/0232430 A1	9/2011	Hale
6,514,026 B1	2/2003	Gerhard	2012/0000327 A1	1/2012	Park
6,592,015 B1	7/2003	Gostylla et al.	2012/0048909 A1	3/2012	Gensmann et al.
6,601,480 B1	8/2003	Habermehl	2012/0073410 A1	3/2012	Hoffman et al.
6,604,901 B1	8/2003	Grossberndt et al.	2013/0051955 A1	2/2013	Su et al.
6,623,228 B1	9/2003	Hettich et al.	2013/0189052 A1 *	7/2013	Barenski, Jr. F16B 35/00
6,666,638 B2	12/2003	Craven			411/402
			2013/0302110 A1 *	11/2013	Park F16B 25/0036
					411/387.1

(56)

References Cited

U.S. PATENT DOCUMENTS

2014/0286728	A1*	9/2014	Park	F16B 25/0015 411/411
2014/0314522	A1*	10/2014	Lin	F16B 25/0057 411/387.1
2015/0233407	A1*	8/2015	Pieciak, Jr.	F16B 25/0042 411/417
2016/0186794	A1*	6/2016	Belinda	F16B 25/0015 411/387.1
2017/0016468	A1*	1/2017	Lin	F16B 25/0015
2017/0227039	A1*	8/2017	Shih	F16B 25/0015
2018/0017092	A1*	1/2018	Hasegawa	F16B 15/02

FOREIGN PATENT DOCUMENTS

DE	4228727	3/1994
DE	4331689	3/1994
EP	1595627	11/2005
EP	1920890	5/2008
EP	1932623	6/2008

EP	1938928	7/2008
EP	2258518	12/2010
EP	2397706	12/2011
EP	2076362	3/2012
GB	191001226	12/1910
GB	167620	8/1921
GB	1009630	11/1965
GB	2127927	4/1984
JP	7217625	8/1995
JP	10329049	12/1998
JP	2000257616	9/2000
JP	2004308732	11/2004
WO	2007091487	8/2007

OTHER PUBLICATIONS

Fiberon DeckPilot 12/09.
<http://www.woodworkersjournal.com/todays-wood-screw-technology-2/> downloaded Feb. 23, 2018.
<http://www.starbornindustries.com/cap-tor-xd-product> downloaded Feb. 26, 2018.

* cited by examiner

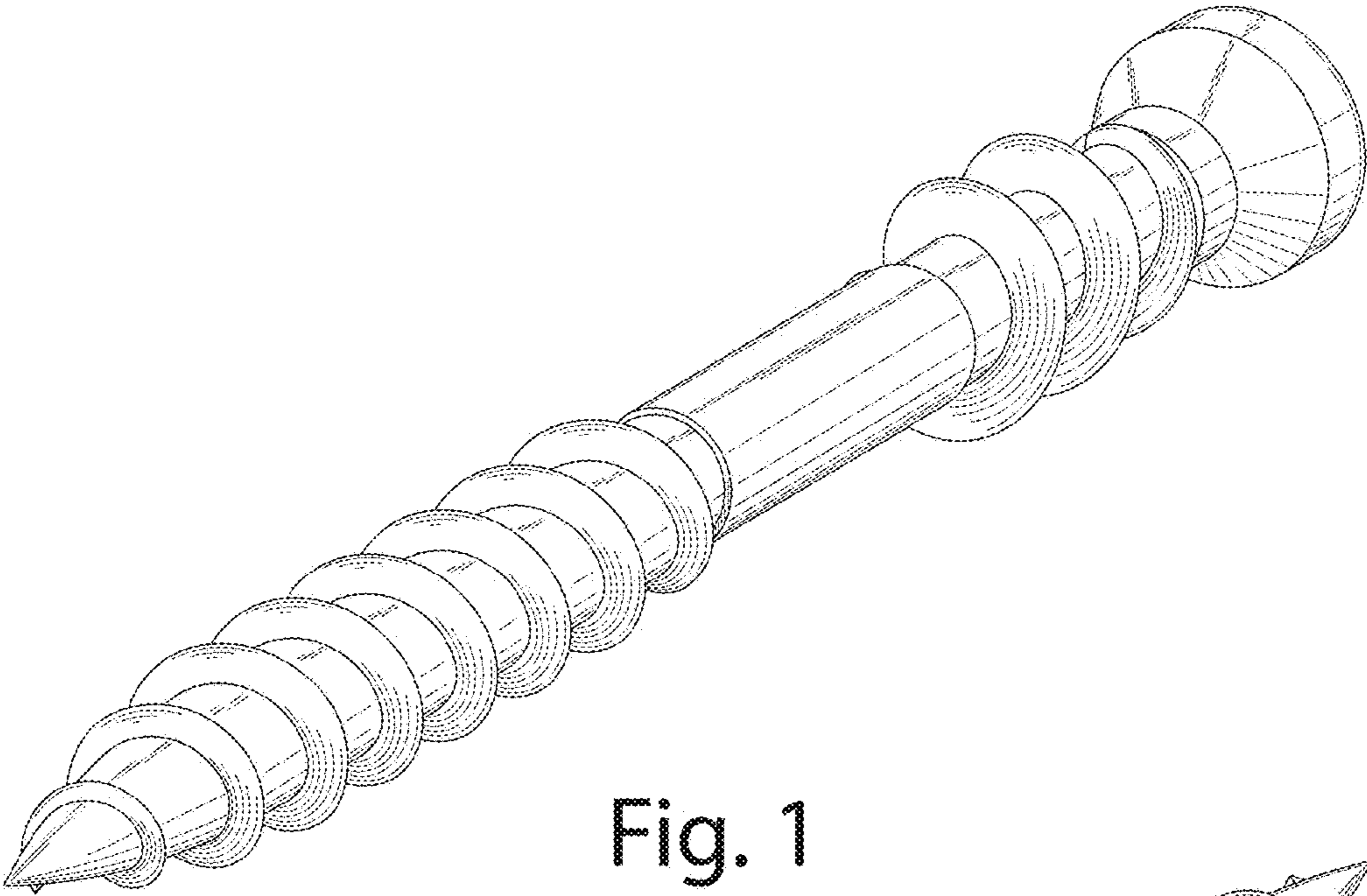

Fig. 1

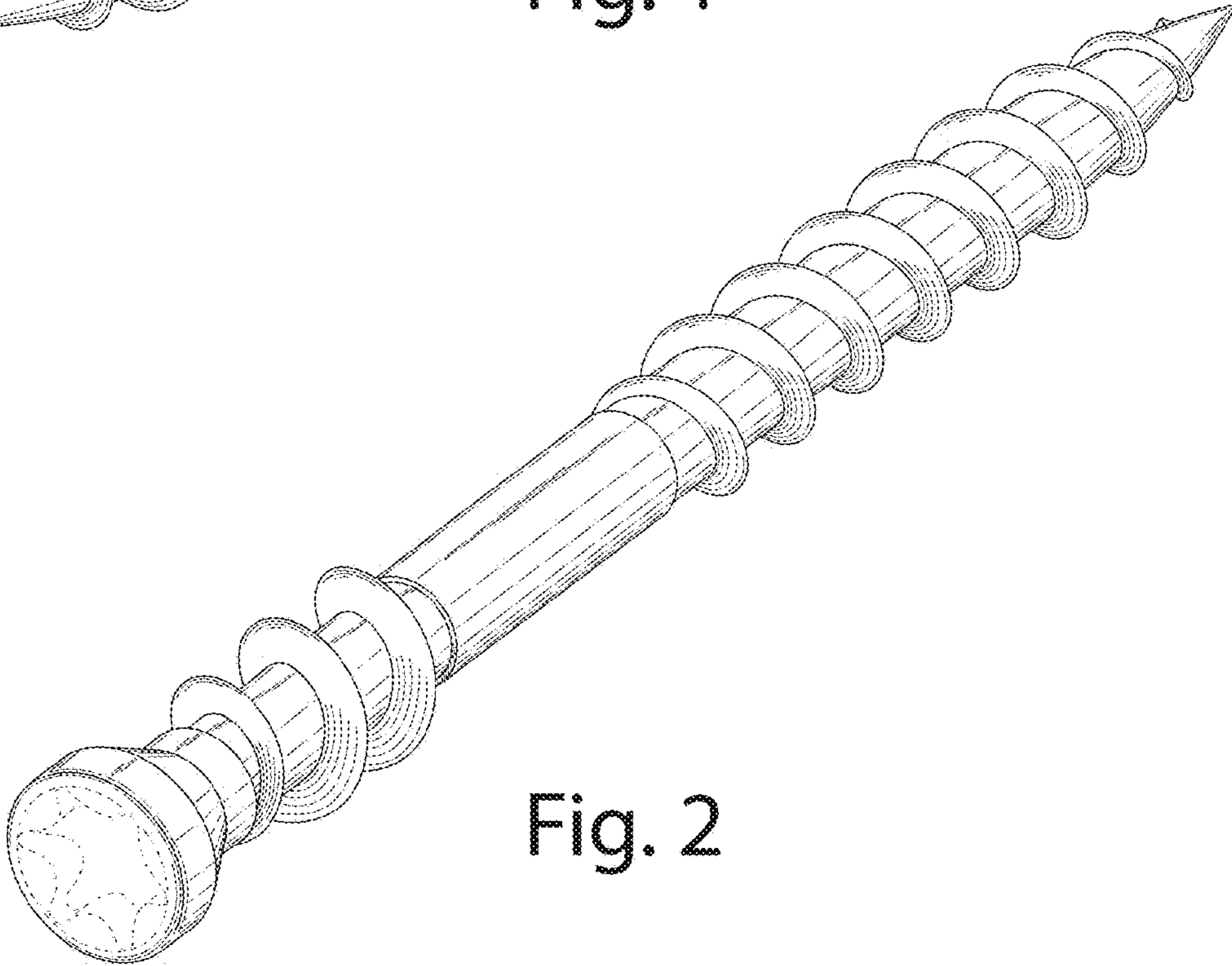

Fig. 2

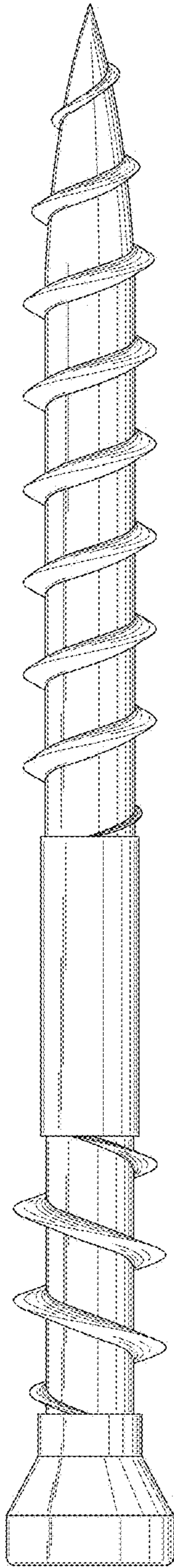

Fig. 3

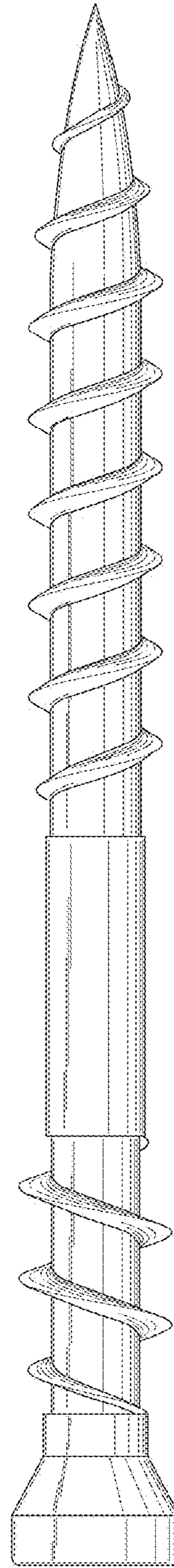

Fig. 4

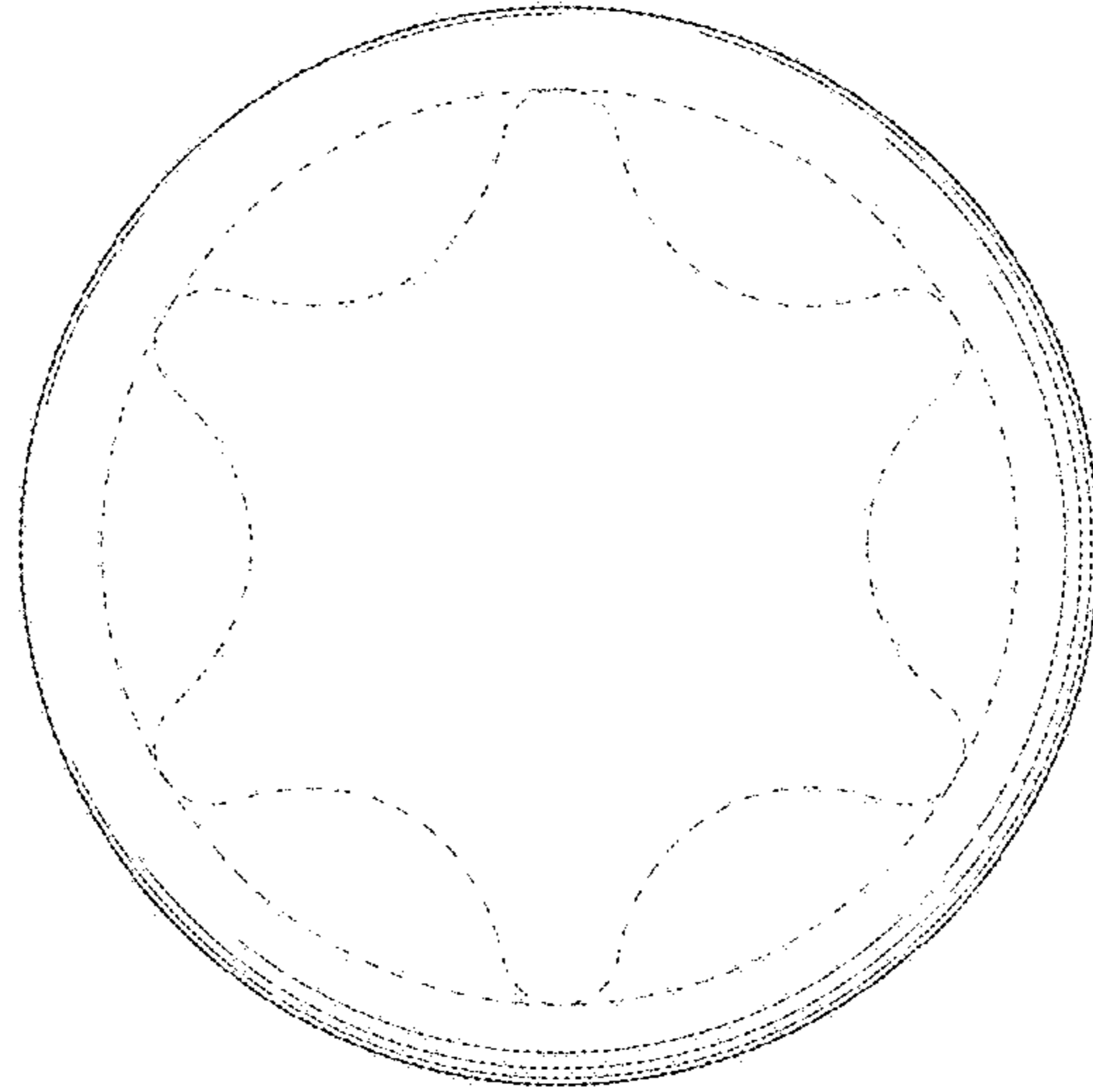

Fig. 5

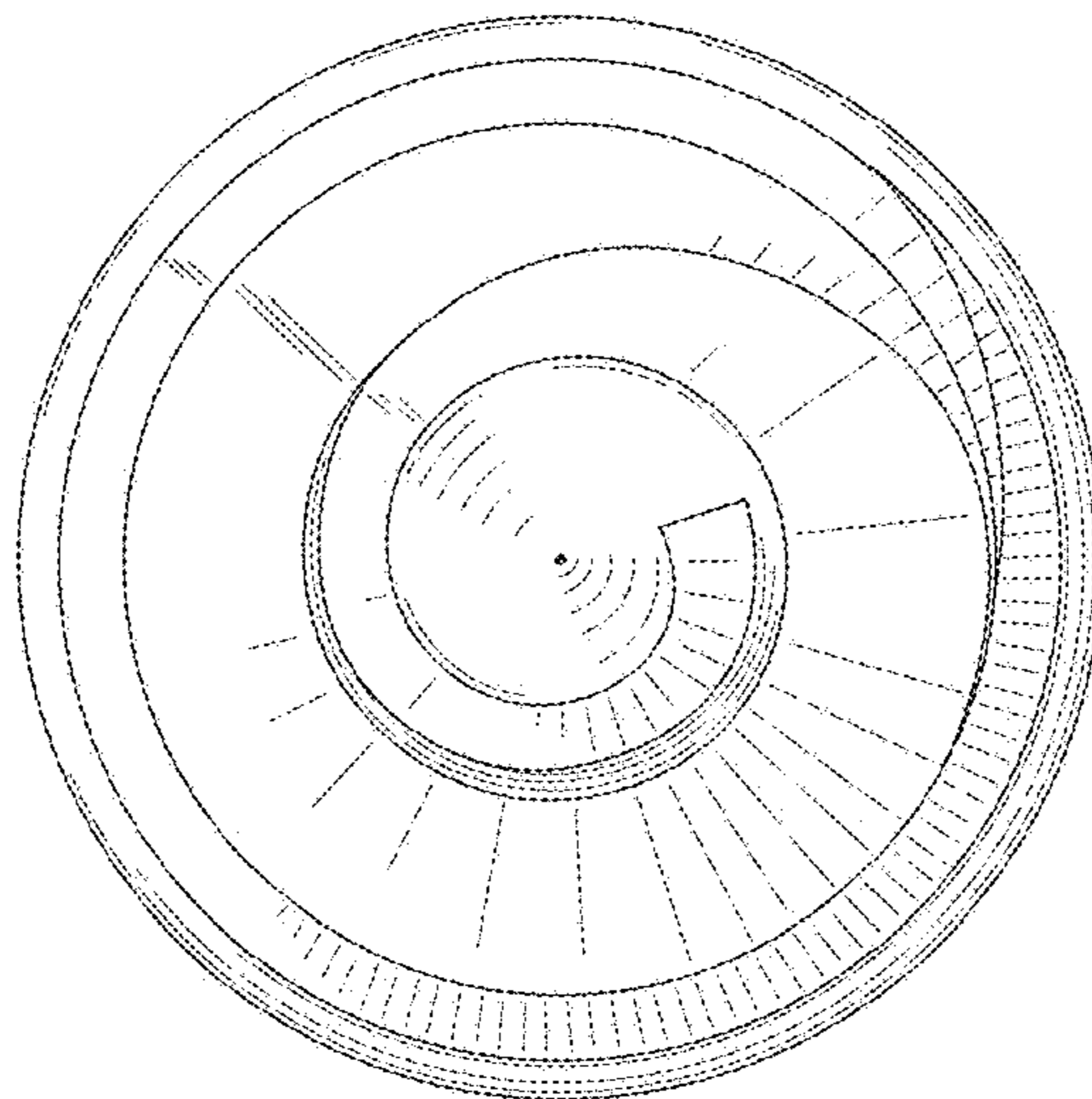

Fig. 6