



US00D841765S

(12) **United States Design Patent**  
**Tappeiner**

(10) **Patent No.:** **US D841,765 S**

(45) **Date of Patent:** **\*\* Feb. 26, 2019**

- (54) **FOUNTAIN**
- (71) Applicant: **FKA Distributing Co., LLC**,  
Commerce Township, MI (US)
- (72) Inventor: **Marc Tappeiner**, Santa Barbara, CA  
(US)
- (73) Assignee: **FKA Distributing Co., LLC**,  
Commerce Township, MI (US)
- (\*\*) Term: **15 Years**
- (21) Appl. No.: **29/625,277**
- (22) Filed: **Nov. 8, 2017**
- (51) **LOC (11) Cl.** ..... **23-01**
- (52) **U.S. Cl.**  
USPC ..... **D23/201**
- (58) **Field of Classification Search**  
USPC ..... D23/201; D11/131; 239/17-23  
CPC ..... B05B 17/08; F21W 2121/02  
See application file for complete search history.

- D394,301 S \* 5/1998 Fisher ..... D23/201
- 5,992,757 A \* 11/1999 Smith ..... B05B 17/08  
239/17
- D419,637 S \* 1/2000 Lavon ..... D23/201
- D454,612 S \* 3/2002 Chang ..... D23/201
- D454,613 S \* 3/2002 Wood ..... D23/201
- 6,981,652 B2 \* 1/2006 Lin ..... B05B 17/08  
239/16
- D557,173 S \* 12/2007 Grantham ..... D11/144
- 7,845,580 B2 \* 12/2010 Liao ..... B05B 17/08  
239/16
- D678,462 S \* 3/2013 Whitis ..... B05B 17/08  
D23/201

\* cited by examiner

*Primary Examiner* — Robin V Webster

(74) *Attorney, Agent, or Firm* — Brooks Kushman P.C.

(57) **CLAIM**

The ornamental design for a fountain, as shown and described.

**DESCRIPTION**

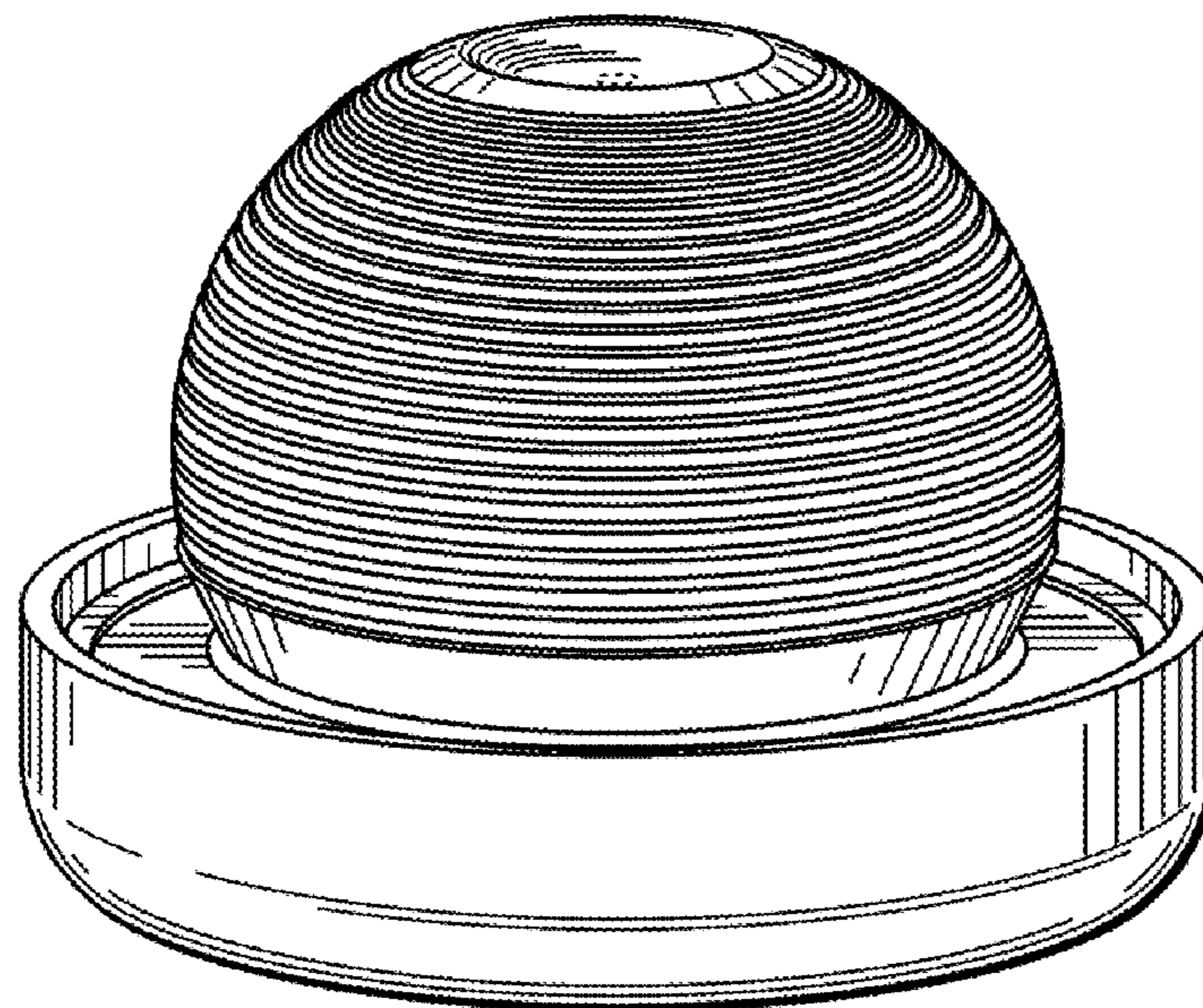
FIG. 1 is a perspective view of a fountain showing my new design;  
 FIG. 2 is a side view of the fountain of FIG. 1;  
 FIG. 3 is a top view of the fountain of FIG. 1; and,  
 FIG. 4 is a bottom view of the fountain of FIG. 1.  
 The broken line showing of a portion of the fountain in FIG. 3 is included for the purpose of illustrating and forms no part of the claimed design.

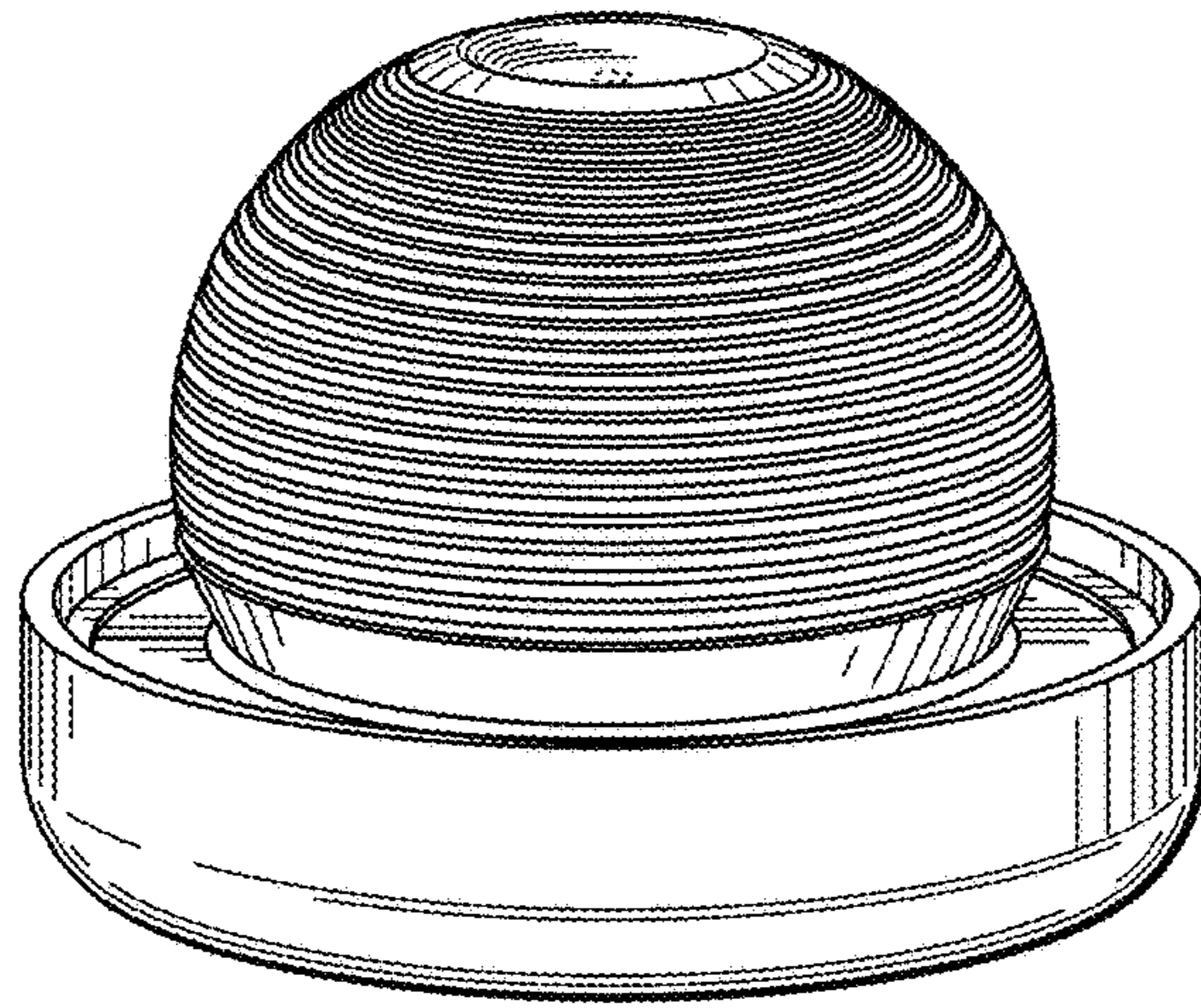
**1 Claim, 2 Drawing Sheets**

(56) **References Cited**

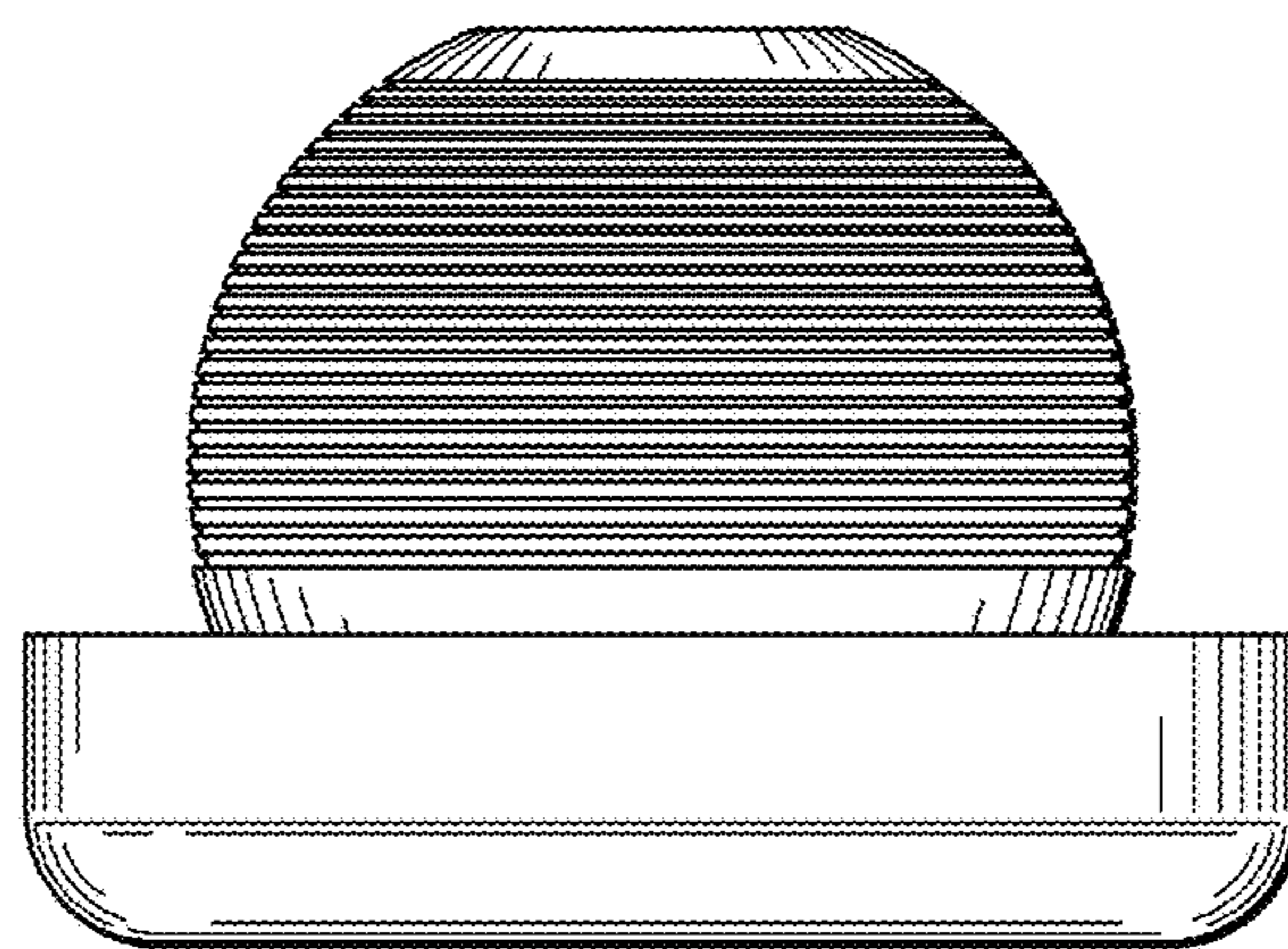
U.S. PATENT DOCUMENTS

- D113,465 S \* 2/1939 Ohrenschall ..... D23/201
- D161,154 S \* 12/1950 Bartholomew ..... B05B 17/08  
D23/201
- D221,755 S \* 9/1971 Johnson ..... D23/201

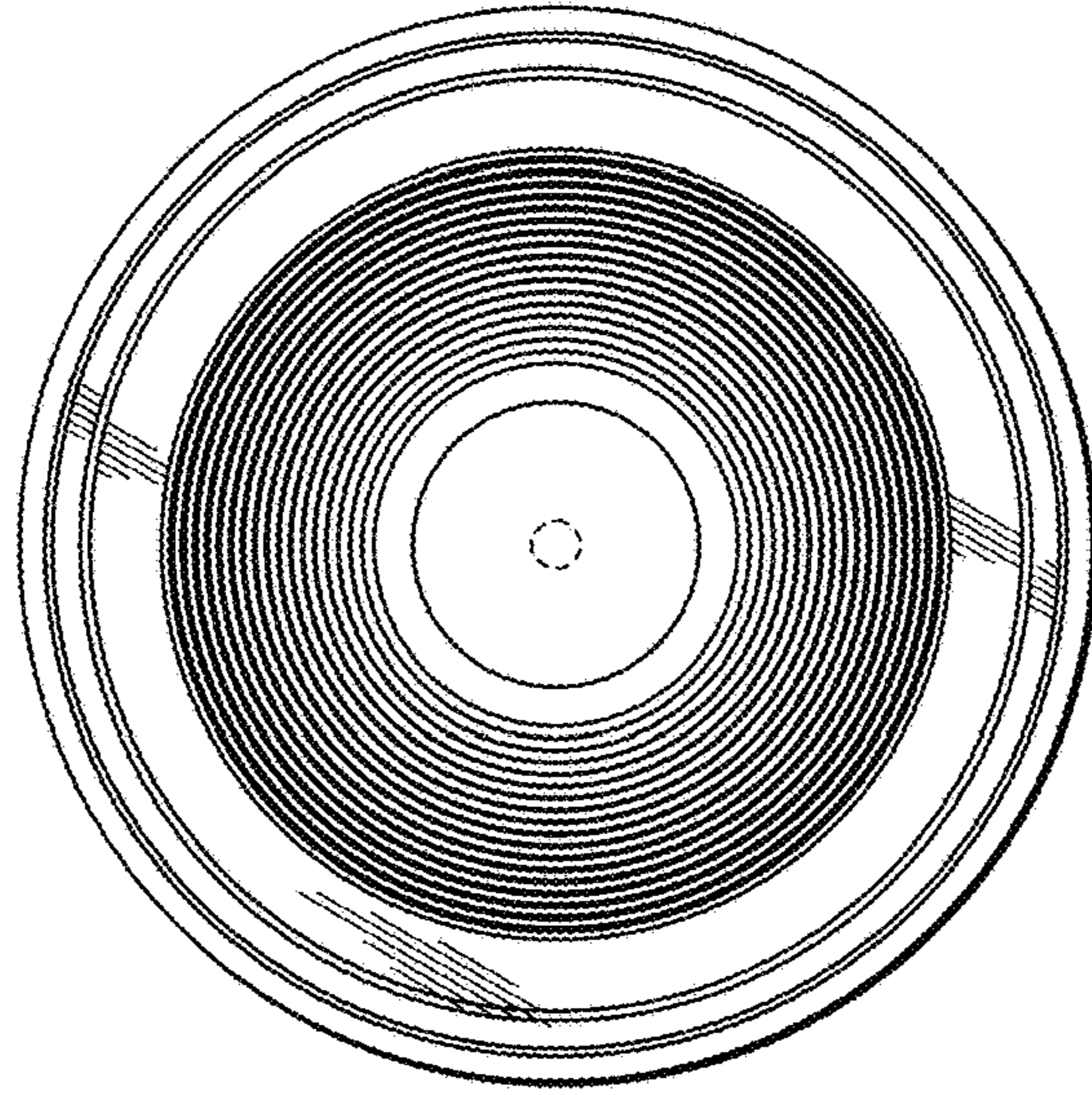




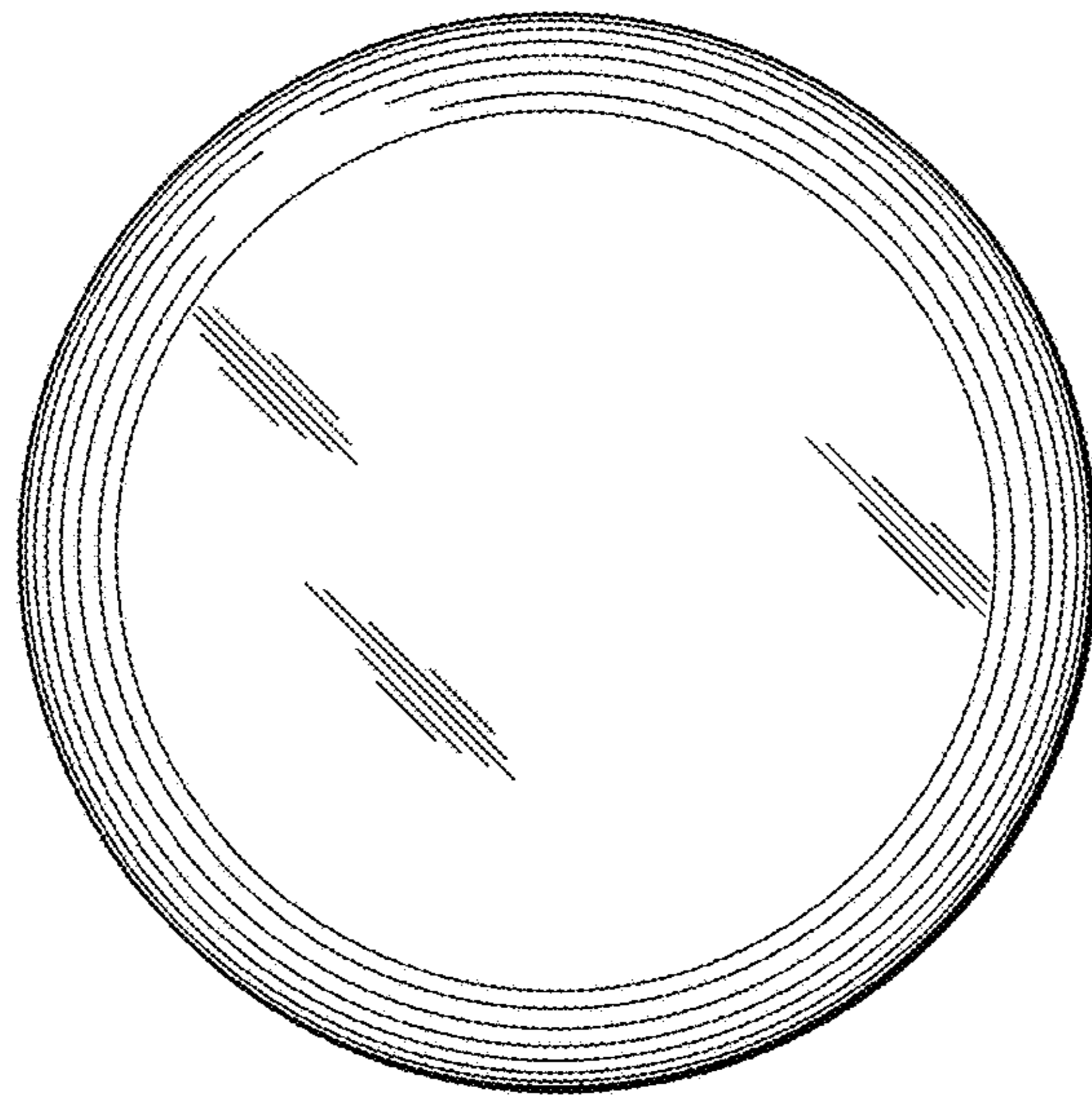
**FIG. 1**



**FIG. 2**



**FIG. 3**



**FIG. 4**