



US00D841712S

(12) **United States Design Patent**
Hontani et al.

(10) **Patent No.:** **US D841,712 S**

(45) **Date of Patent:** **** Feb. 26, 2019**

(54) **INDUSTRIAL ROBOT**

(71) Applicant: **NACHI-FUJIKOSHI CORP.**, Tokyo (JP)

(72) Inventors: **Takeshi Hontani**, Toyama (JP); **Shinya Sasaki**, Tokyo (JP)

(73) Assignee: **NACHI-FUJIKOSHI CORP.**, Tokyo (JP)

(**) Term: **15 Years**

(21) Appl. No.: **29/634,452**

(22) Filed: **Jan. 22, 2018**

(30) **Foreign Application Priority Data**

Jul. 24, 2017 (JP) 2017-015854

(51) **LOC (11) Cl.** **15-99**

(52) **U.S. Cl.**
USPC **D15/199**

(58) **Field of Classification Search**
USPC 15/122, 199; 21/578-583, 621, 622;
23/259, 262, 263
CPC A63H 3/00; B25J 9/00; B25J 9/104; B25J
9/161; B25J 9/1617; G05B 19/00; G05B
2219/33105; G05B 2219/36433; G05B
2219/39335; G05B 2219/39427; G05B
2219/40304; G06C 7/60; G06N 3/00;
G06N 3/004; G06N 3/006; G06N 3/008;
G06N 5/00

See application file for complete search history.

(56) **References Cited**

U.S. PATENT DOCUMENTS

D461,484 S * 8/2002 Kraft D15/199
D646,703 S * 10/2011 Wong D15/199
D650,820 S * 12/2011 Long D15/199

D655,324 S * 3/2012 Wong D15/199
D670,319 S * 11/2012 Liu D15/199
D677,294 S * 3/2013 Long D15/199
D692,041 S * 10/2013 Selic D15/199
D716,357 S * 10/2014 Gombert D15/199
D761,339 S * 7/2016 White, Jr. D15/199
D766,348 S * 9/2016 Long D15/199
D776,178 S * 1/2017 Ries D15/199
D802,041 S * 11/2017 He D15/199
D824,977 S * 8/2018 Everman D15/199
D830,439 S * 10/2018 Park D15/199
2010/0131099 A1* 5/2010 Birkenbach G05B 19/402
700/254
2011/0064554 A1* 3/2011 Ito B25J 9/047
414/735
2011/0107866 A1* 5/2011 Oka B25J 9/0084
74/490.03
2013/0116821 A1* 5/2013 Joly B25J 9/161
700/254
2013/0125694 A1* 5/2013 Long B25J 11/0075
74/490.01

(Continued)

Primary Examiner — Patricia A Palasik

(74) *Attorney, Agent, or Firm* — Christensen, Fonder,
Dardi & Herbert PLLC

(57) **CLAIM**

The ornamental design for an industrial robot, as shown and described.

DESCRIPTION

FIG. 1 is a front, top, and right side perspective view of an industrial robot;
FIG. 2 is a rear, top, and left side perspective view thereof;
FIG. 3 is a front view thereof;
FIG. 4 is a rear view thereof;
FIG. 5 is a top plan view thereof;
FIG. 6 is a bottom plan view thereof;
FIG. 7 is a right side view thereof; and,
FIG. 8 is a left side view thereof.

1 Claim, 8 Drawing Sheets

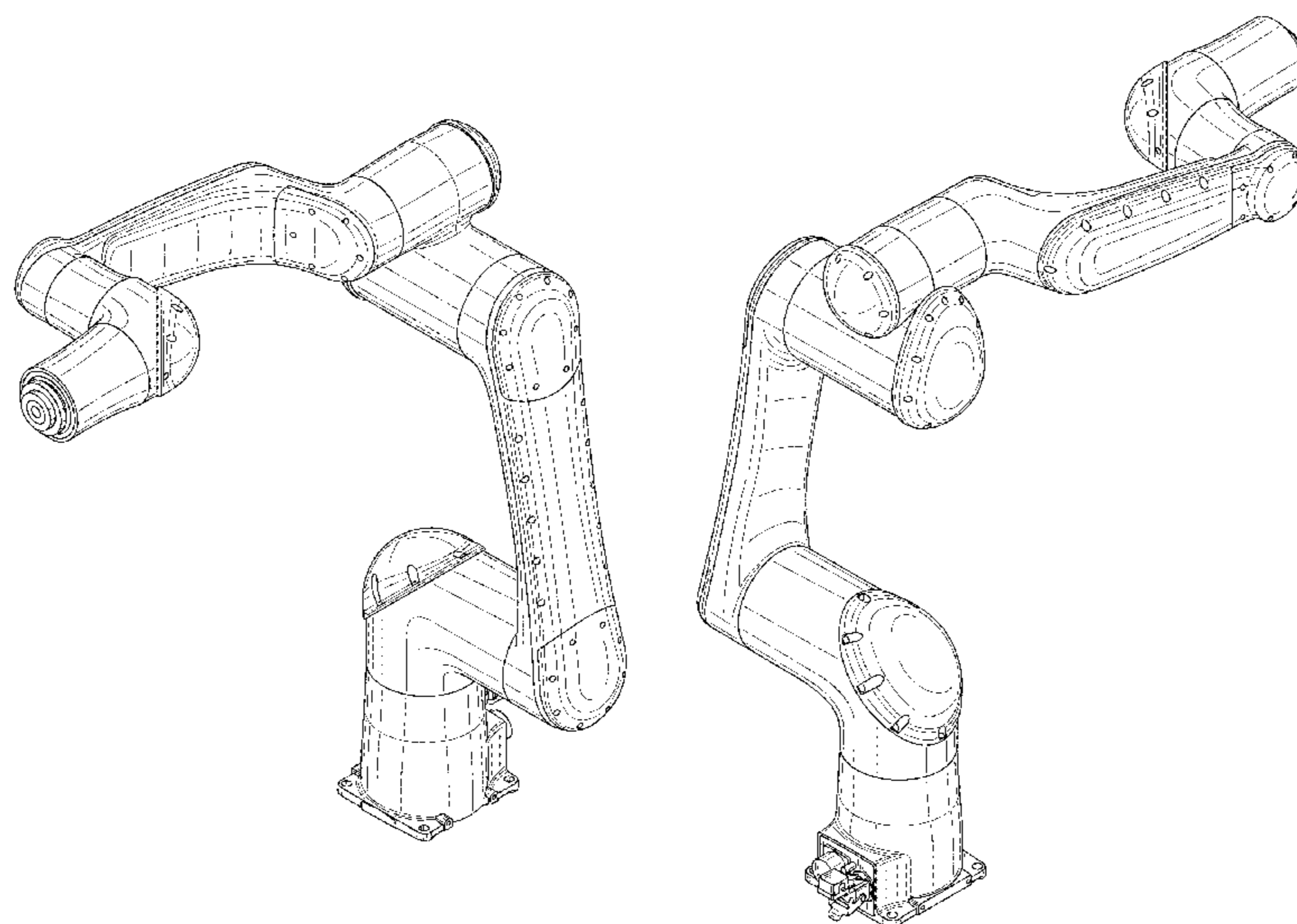

(56)

References Cited

U.S. PATENT DOCUMENTS

2014/0102239 A1* 4/2014 Umeno B25J 15/0033
74/490.01
2014/0137687 A1* 5/2014 Nogami B25J 18/00
74/490.03
2016/0331482 A1* 11/2016 Hares B25J 9/1689

* cited by examiner

FIG. 1

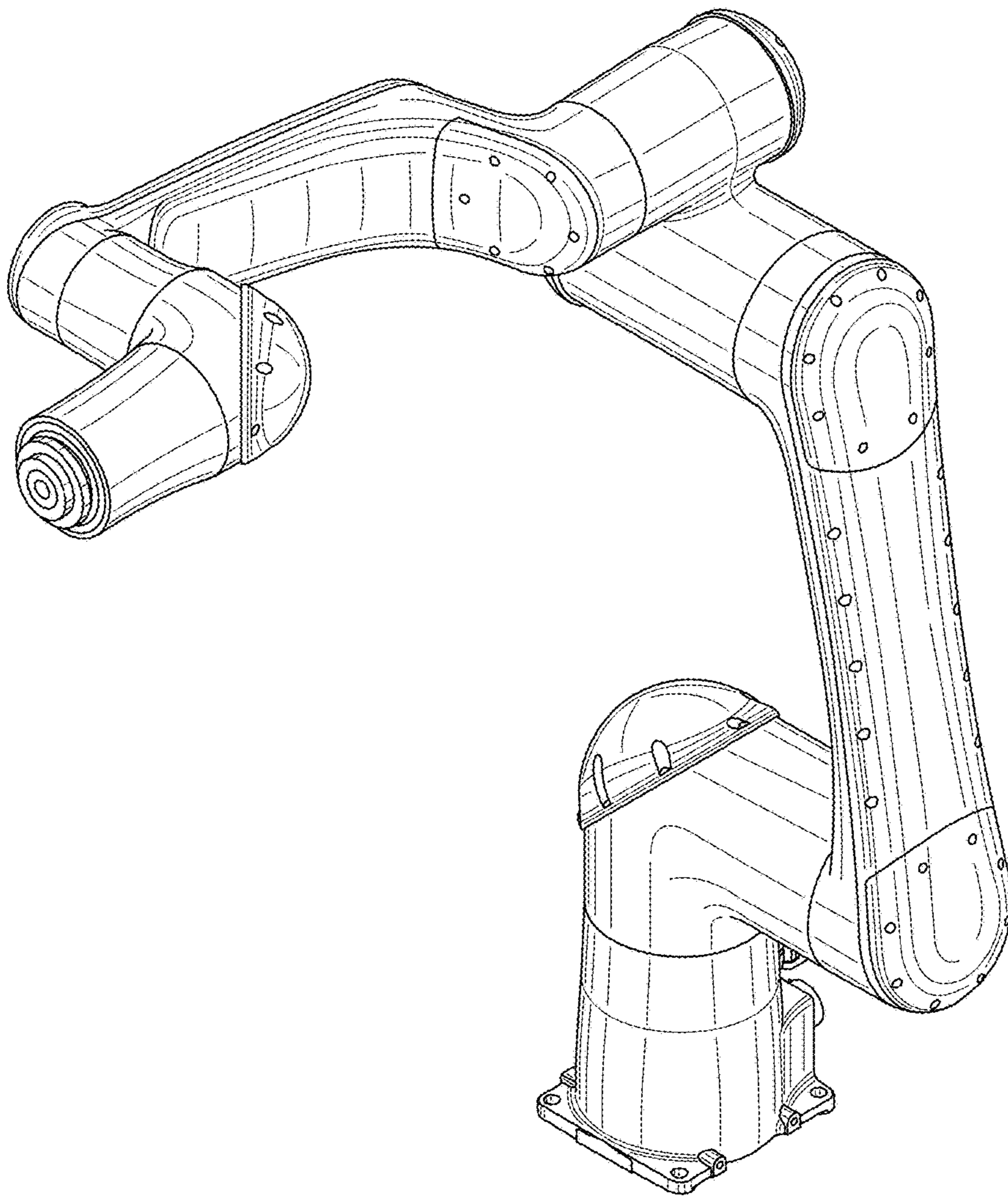

FIG. 2

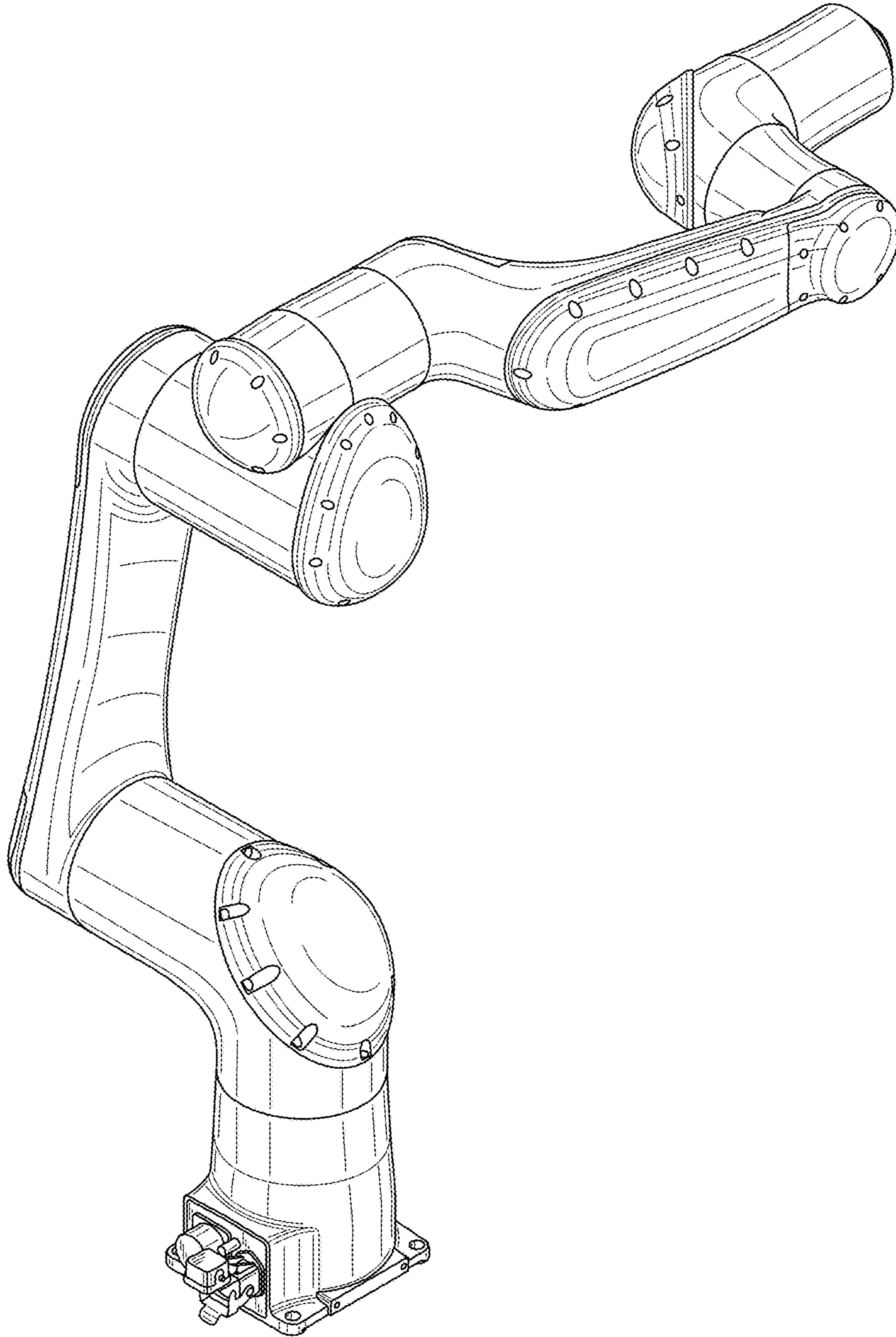

FIG. 3

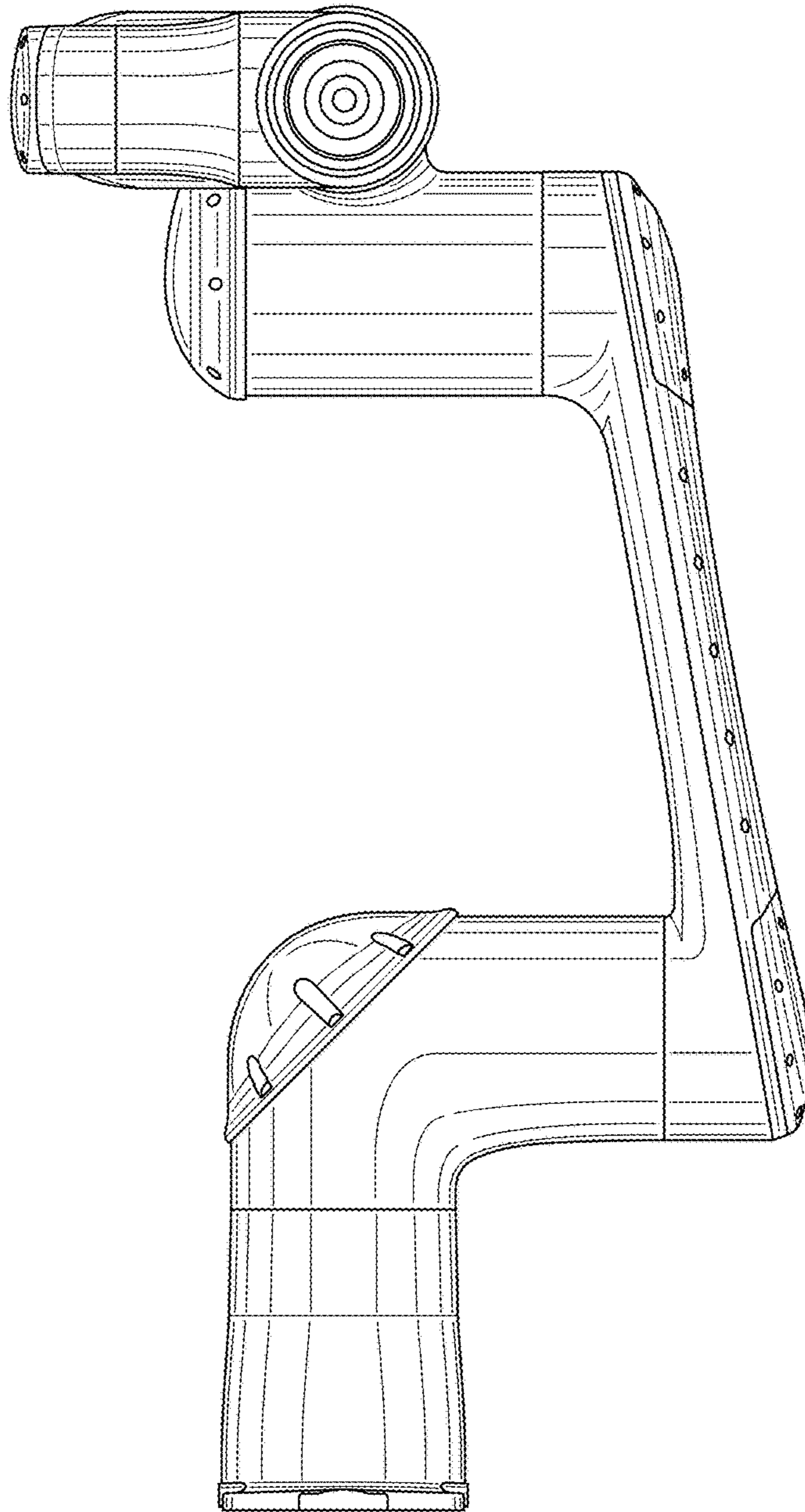

FIG. 4

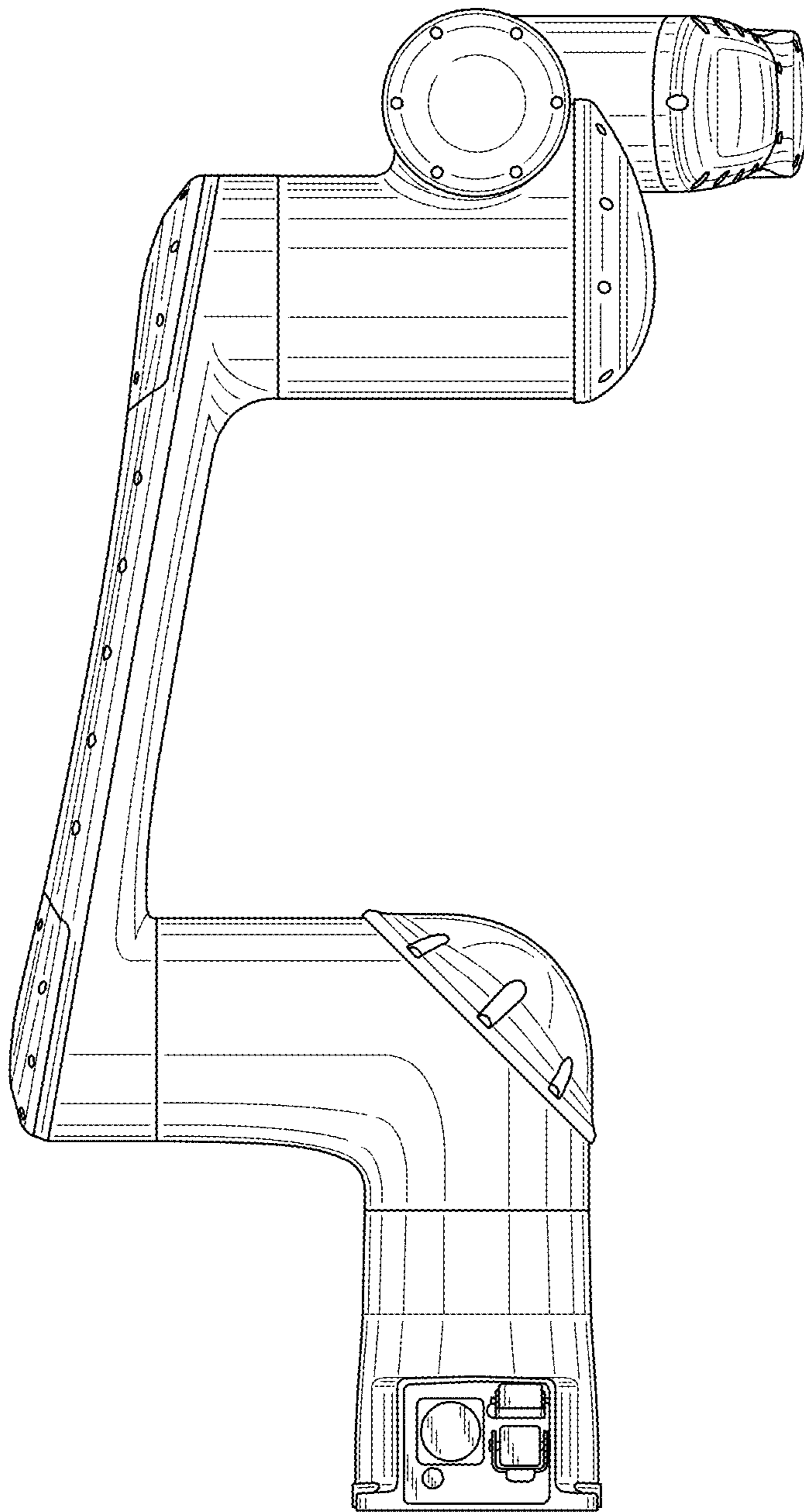

FIG. 5

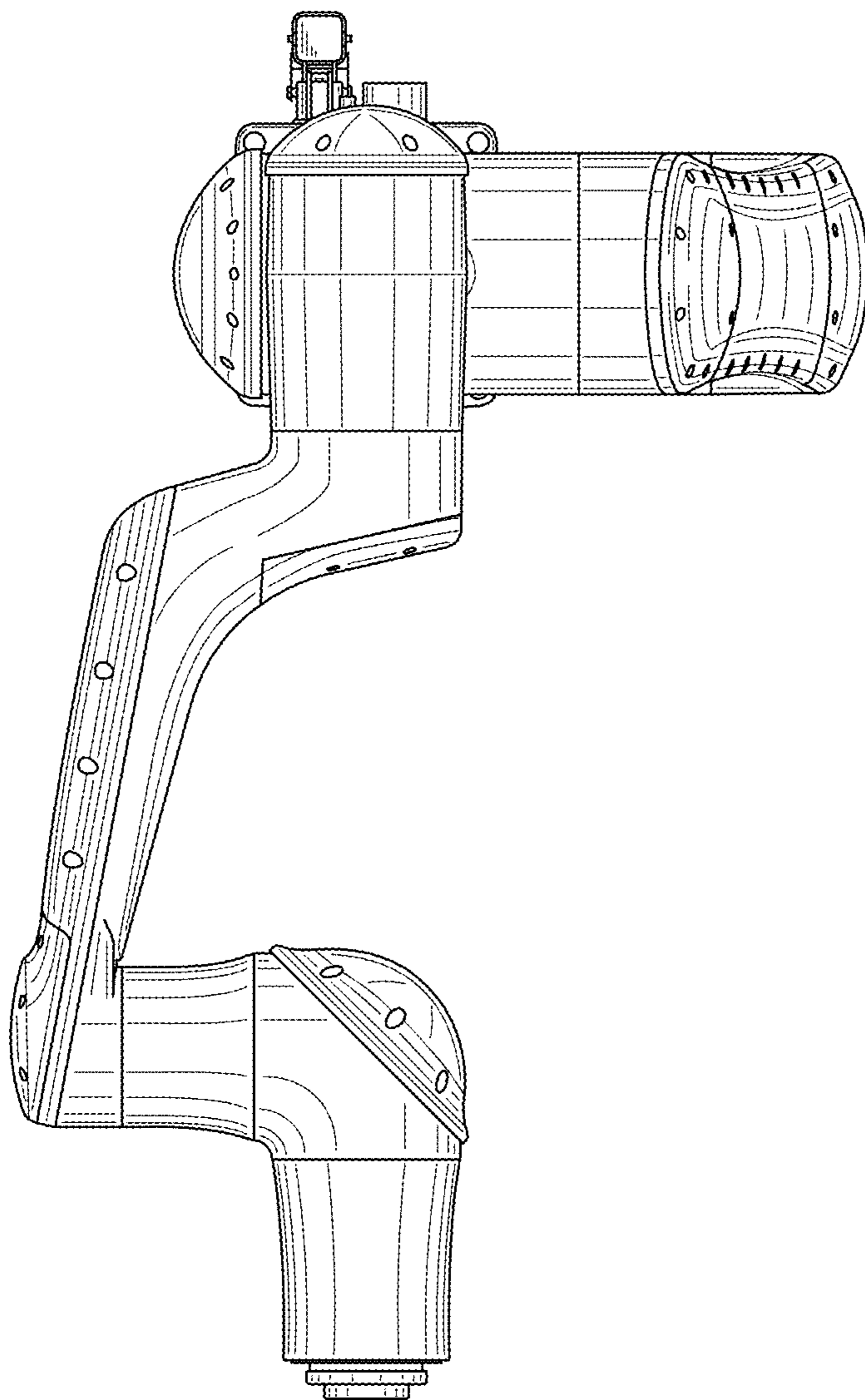

FIG. 6

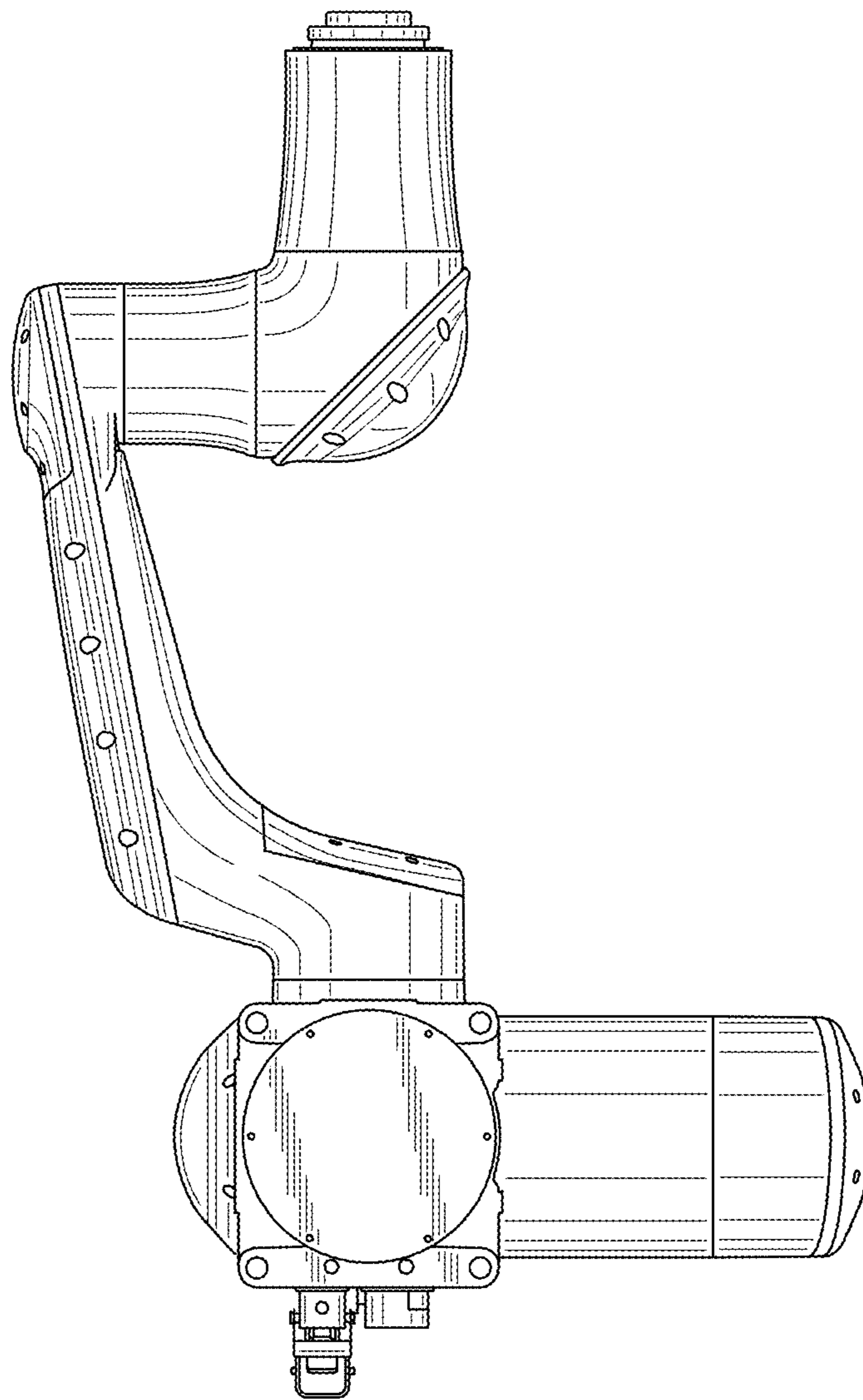

FIG. 7

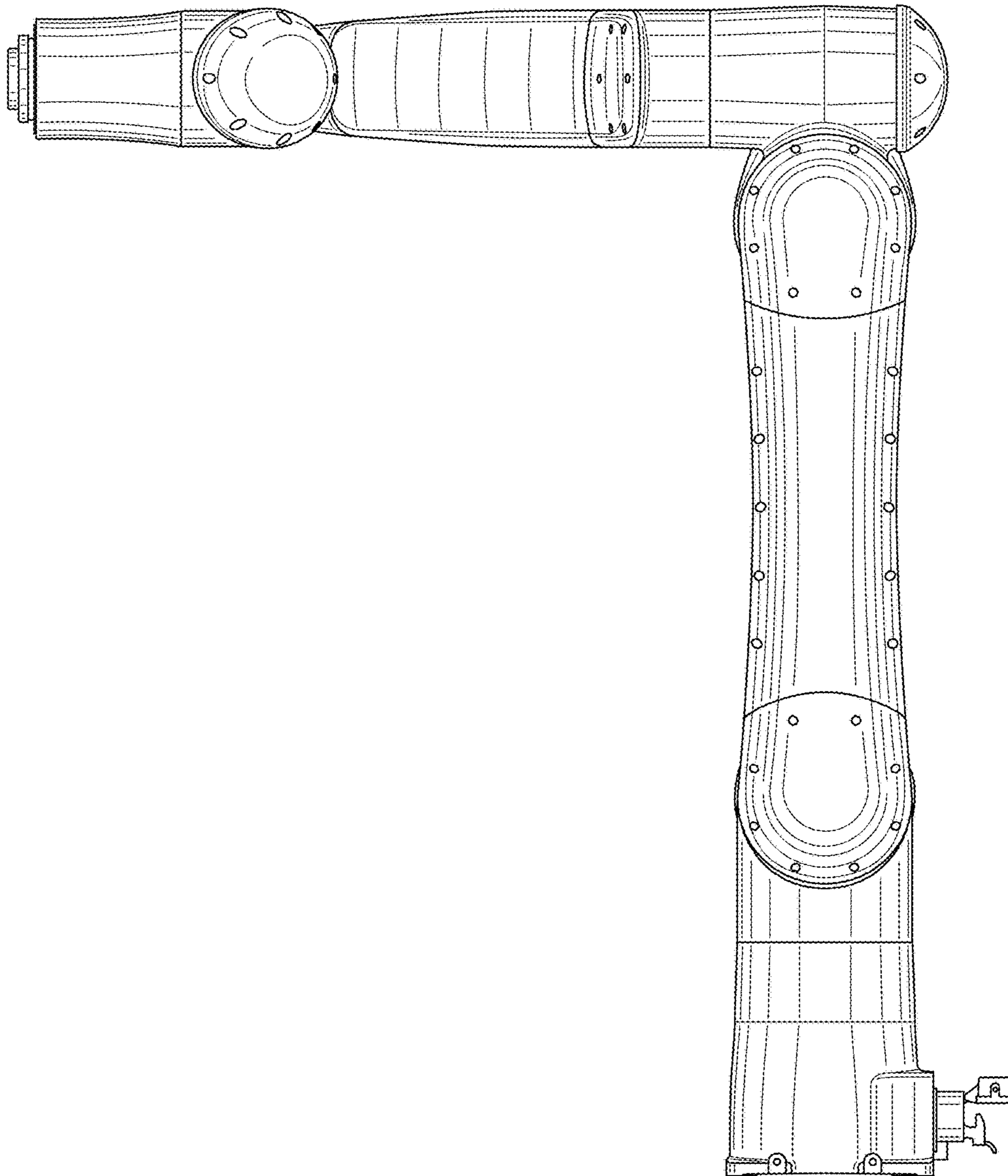

FIG. 8

