



US00D841564S

(12) **United States Design Patent** (10) **Patent No.:** **US D841,564 S**
Sartin (45) **Date of Patent:** **** Feb. 26, 2019**

(54) **CARGO CARRIER**

(71) Applicant: **PAKMULE, LLC**, Houston, TX (US)

(72) Inventor: **Kansas Ryan Sartin**, Houston, TX (US)

(73) Assignee: **PAKMULE, LLC**, Houston, TX (US)

(**) Term: **15 Years**

(21) Appl. No.: **29/625,572**

(22) Filed: **Nov. 10, 2017**

(51) **LOC (11) Cl.** **12-16**

(52) **U.S. Cl.**
USPC **D12/406**

(58) **Field of Classification Search**
USPC D12/400–406; D6/610–611
CPC B60R 9/00; B60R 9/02; B60R 9/04; B60R 9/08; B60R 9/042; B60R 9/0423; B60R 9/0426; B60R 9/045; B60R 9/048; B60R 9/0485; B60R 9/05; B60R 9/052; B60R 9/055; B60R 9/058; B60R 9/06; B60R 9/065; B60R 9/10; B60R 9/12
See application file for complete search history.

(56) **References Cited**

U.S. PATENT DOCUMENTS

D459,287 S *	6/2002	Beard	D12/406
D528,965 S *	9/2006	Wang	D12/406
D586,287 S *	2/2009	McBride	D12/106
D593,927 S *	6/2009	Walton	D12/406
D660,748 S *	5/2012	Cooley	D12/101
D713,775 S *	9/2014	Lagermann	D12/406

(Continued)

Primary Examiner — Katrina A Betton

(74) *Attorney, Agent, or Firm* — Edmonds & Cmaidalka, P.C.

(57) **CLAIM**

The ornamental design for a cargo carrier, as shown and described.

DESCRIPTION

FIG. 1 is perspective view showing a rear side of a cargo carrier, and its top side;
 FIG. 2 is a perspective view of the carrier of FIG. 1 showing the rear and bottom sides;
 FIG. 3 is a perspective view of the carrier of FIG. 1 showing the front side;
 FIG. 4 is a perspective view of the carrier of FIG. 1 showing the rear side;
 FIG. 5 is a perspective view of the carrier of FIG. 1 showing the top side;
 FIG. 6 is a perspective view thereof of the carrier of FIG. 1 the bottom side;
 FIG. 7 is a right side elevation view of the carrier of FIG. 1;
 FIG. 8 is a left side elevation view of the carrier of FIG. 1;
 FIG. 9 is a rear elevation view of the carrier of FIG. 1;
 FIG. 10 is a front elevation view of the carrier of FIG. 1;
 FIG. 11 is perspective view showing a rear side of a second embodiment of the cargo carrier, and its top side;
 FIG. 12 is a perspective view of the carrier of FIG. 11 showing the rear and bottom sides;
 FIG. 13 is a perspective view of the carrier of FIG. 11 showing the top side;
 FIG. 14 is a perspective view of the carrier of FIG. 11 showing the bottom side;
 FIG. 15 is a right side elevation view of the carrier of FIG. 11;
 FIG. 16 is a left side elevation view of the carrier of FIG. 11;
 FIG. 17 is a rear elevation view of the carrier of FIG. 11; and,
 FIG. 18 is a front elevation view of the carrier of FIG. 11.
 The broken lines in the drawings represent portions of the structure that form no part of the claimed design.

1 Claim, 9 Drawing Sheets

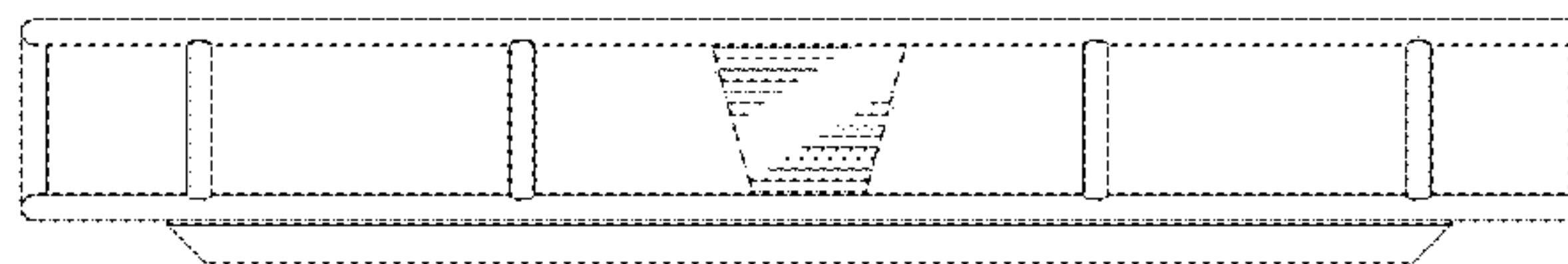
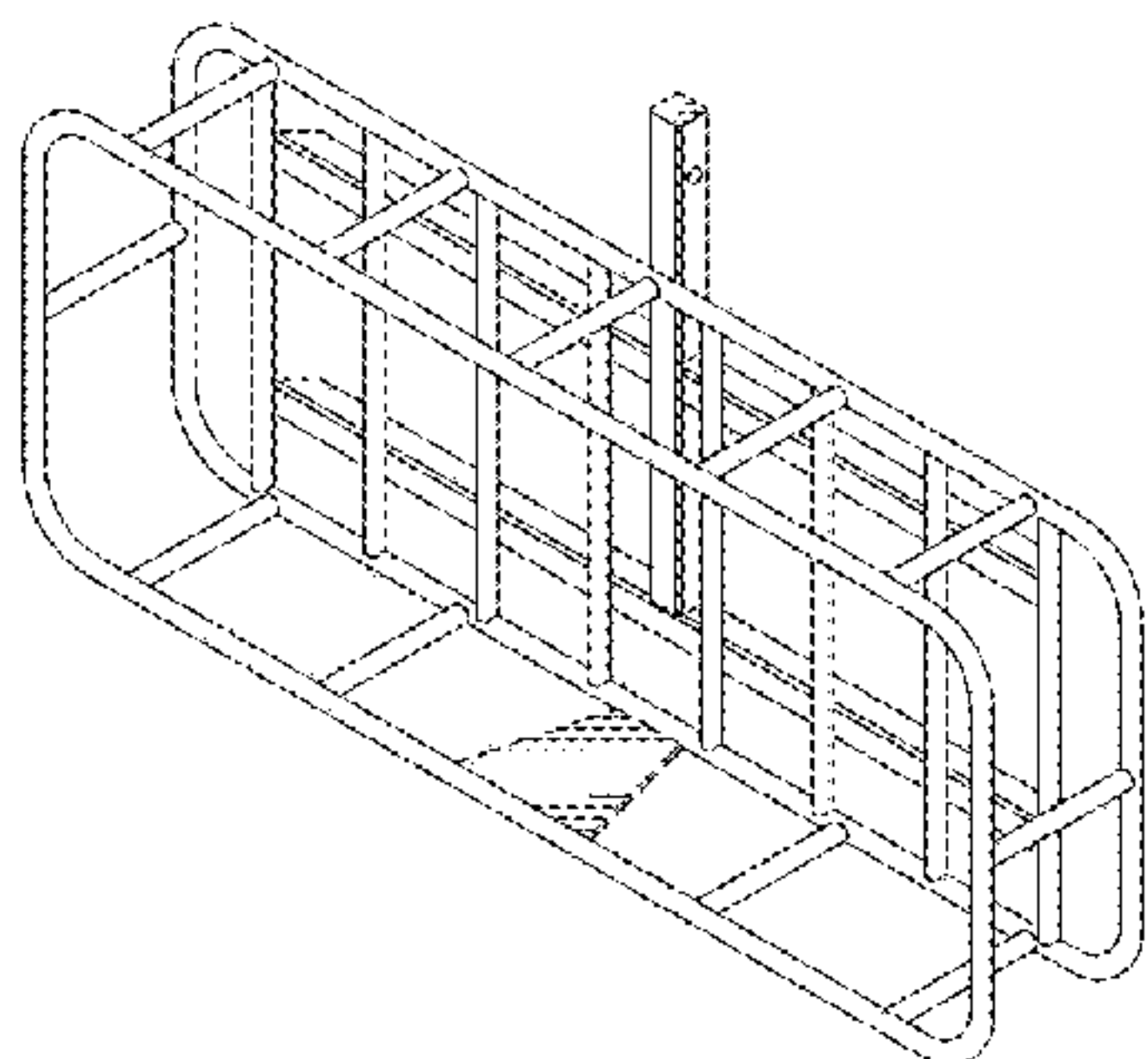

(56)

References Cited

U.S. PATENT DOCUMENTS

D743,870 S	*	11/2015	Galley	D12/406
D754,055 S	*	4/2016	Harrison	D12/406
D755,686 S	*	5/2016	Clark	D12/406
D790,433 S	*	6/2017	Descoteaux	D12/406
D808,888 S	*	1/2018	Puchkoff	D12/406
D817,852 S	*	5/2018	Mifsud	D12/406

* cited by examiner

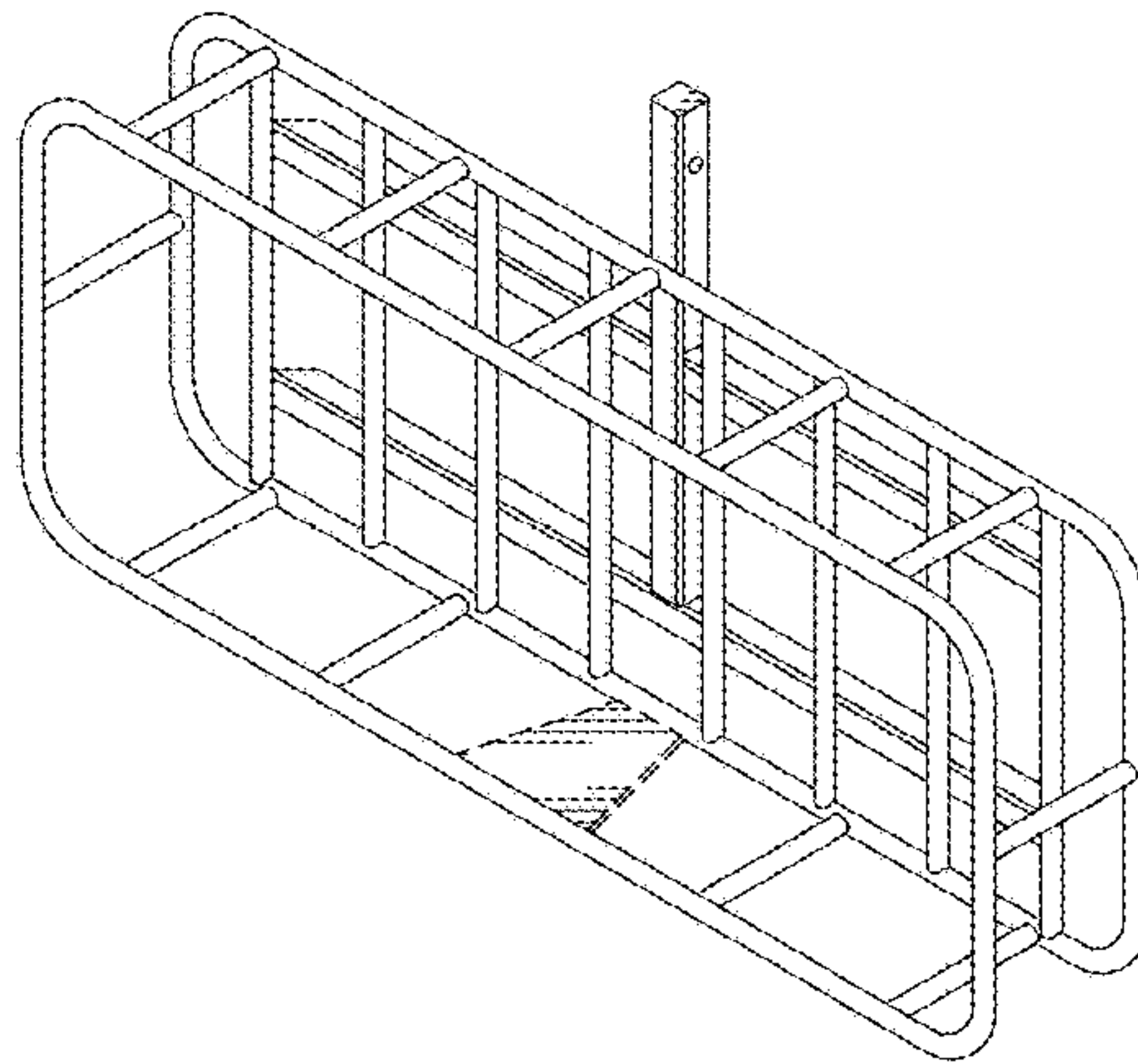

FIG. 1

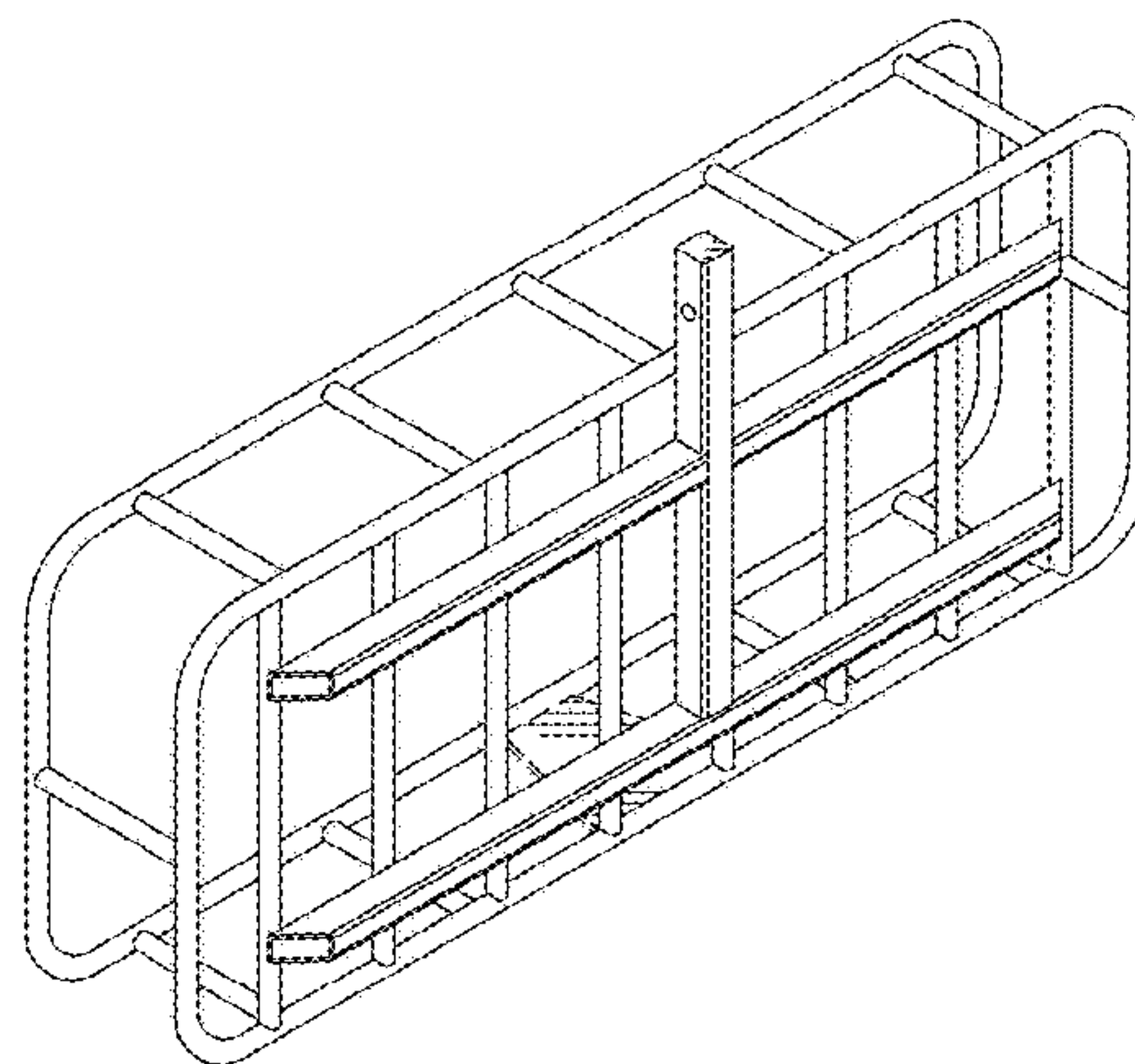

FIG. 2

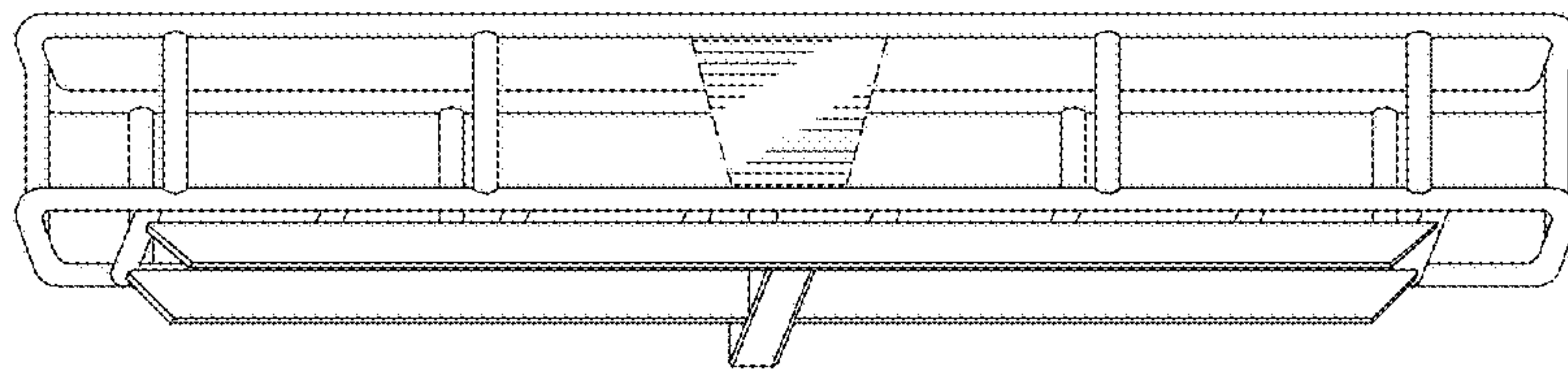

FIG. 3

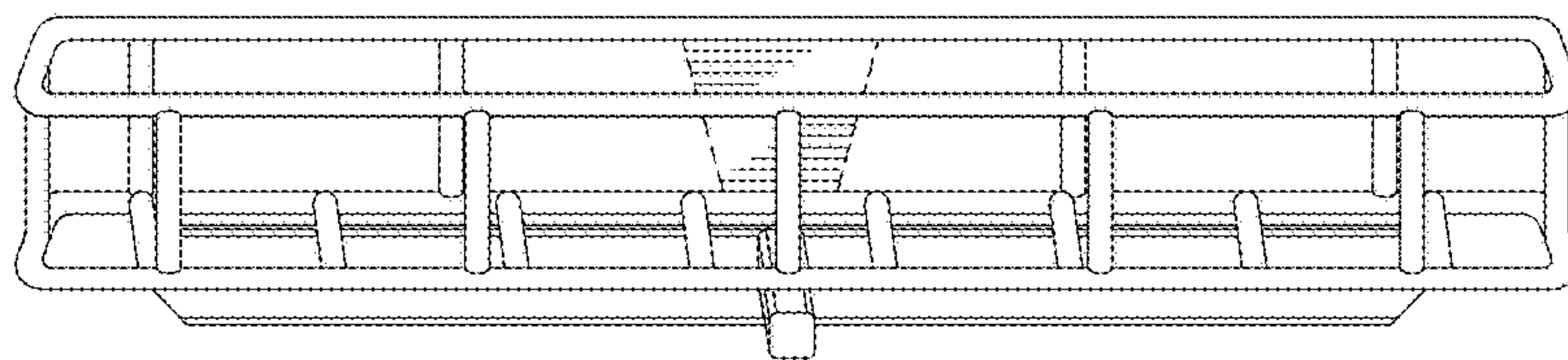

FIG. 4

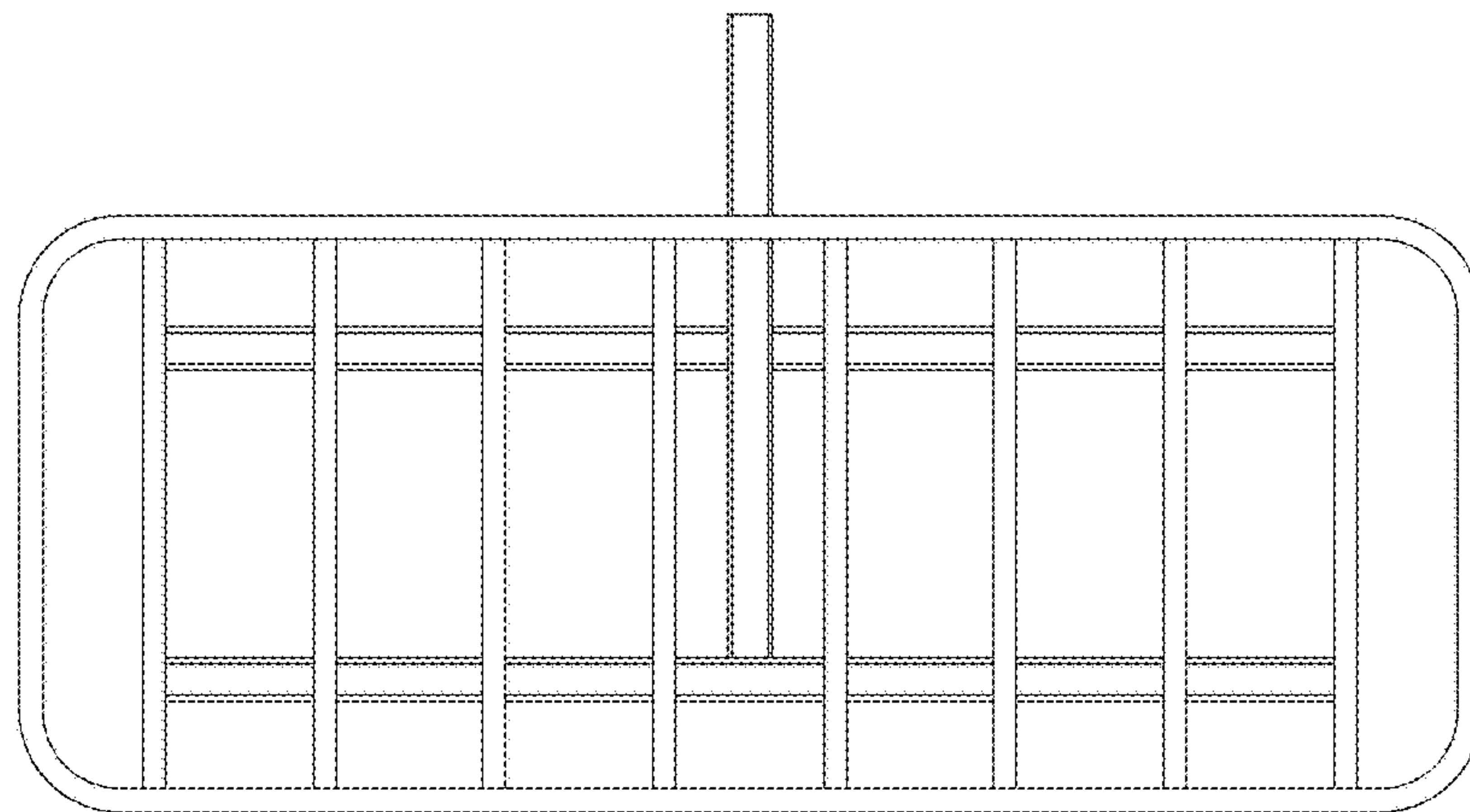

FIG. 5

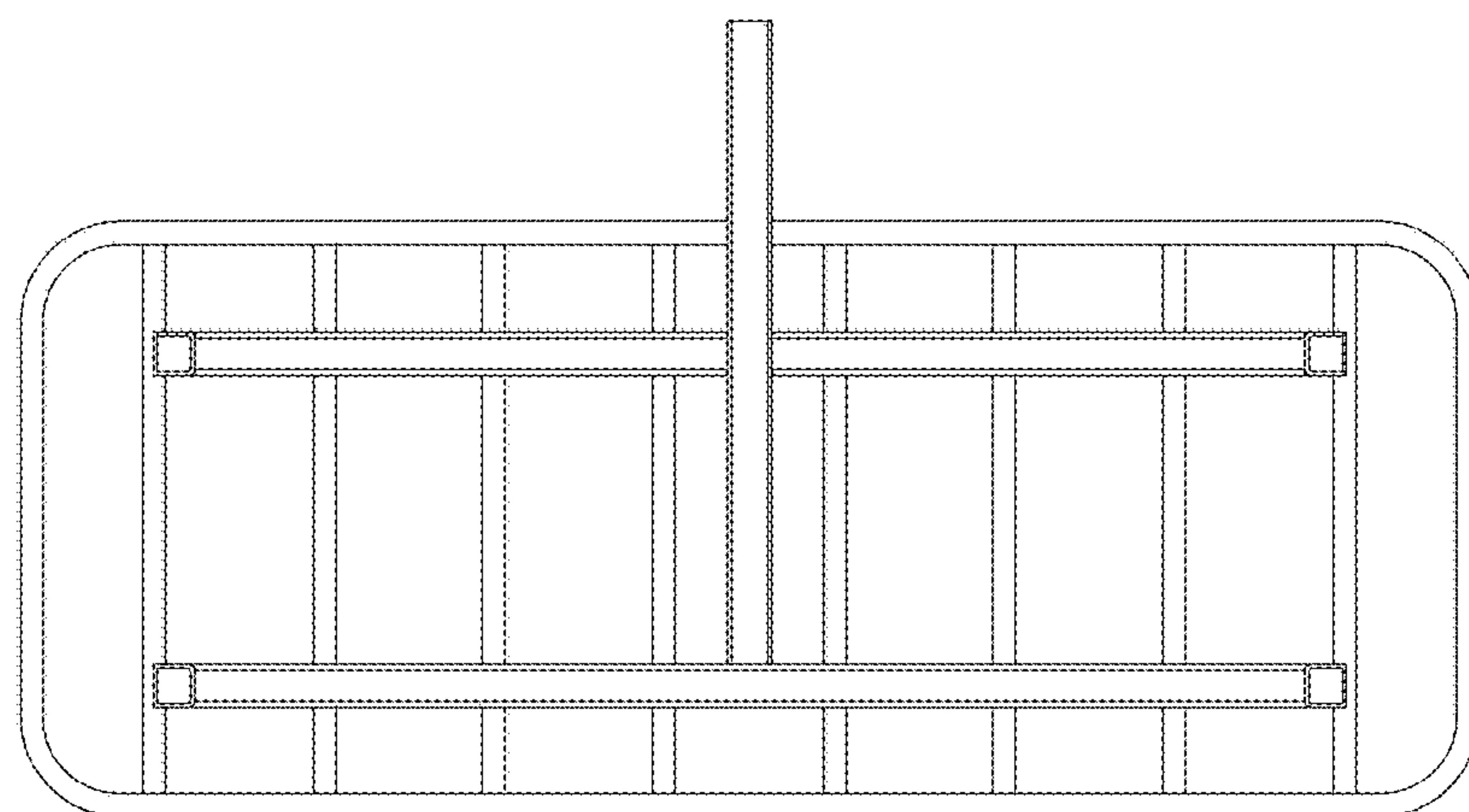

FIG. 6

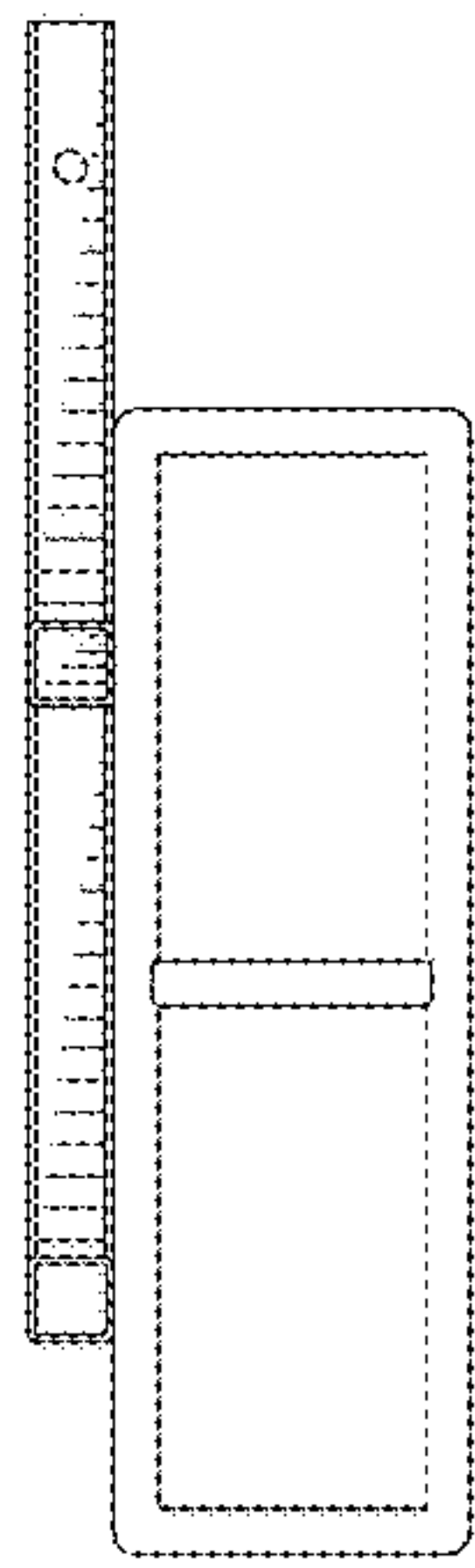

FIG. 7

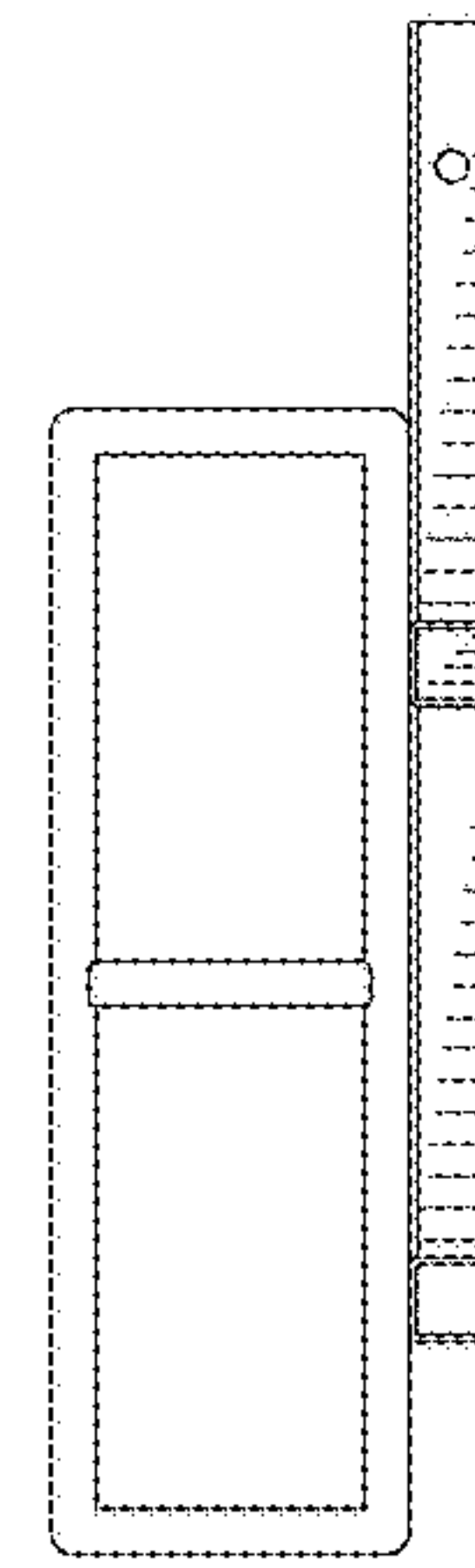

FIG. 8

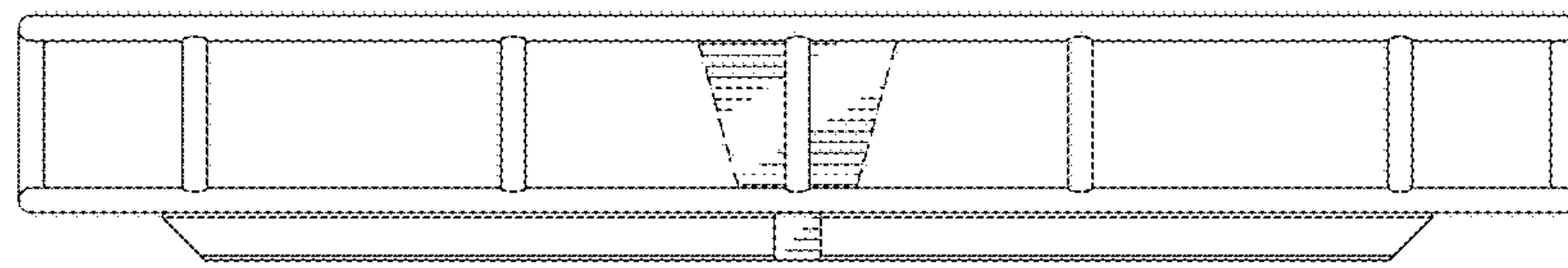

FIG. 9

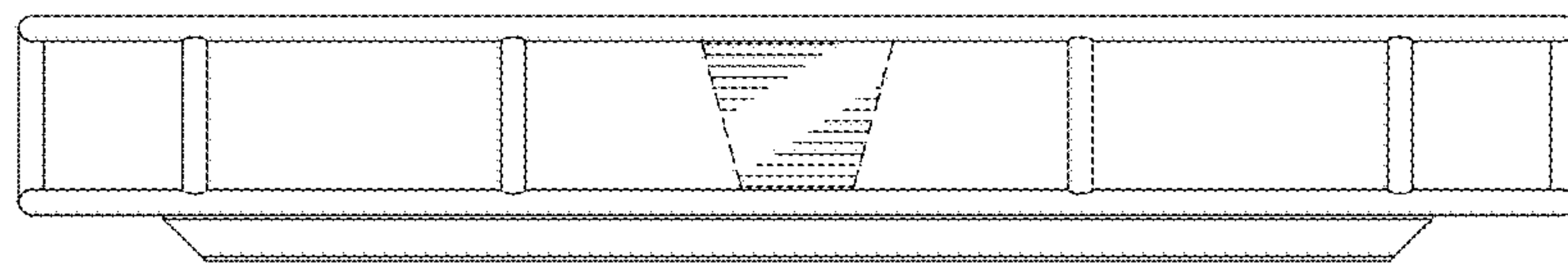

FIG. 10

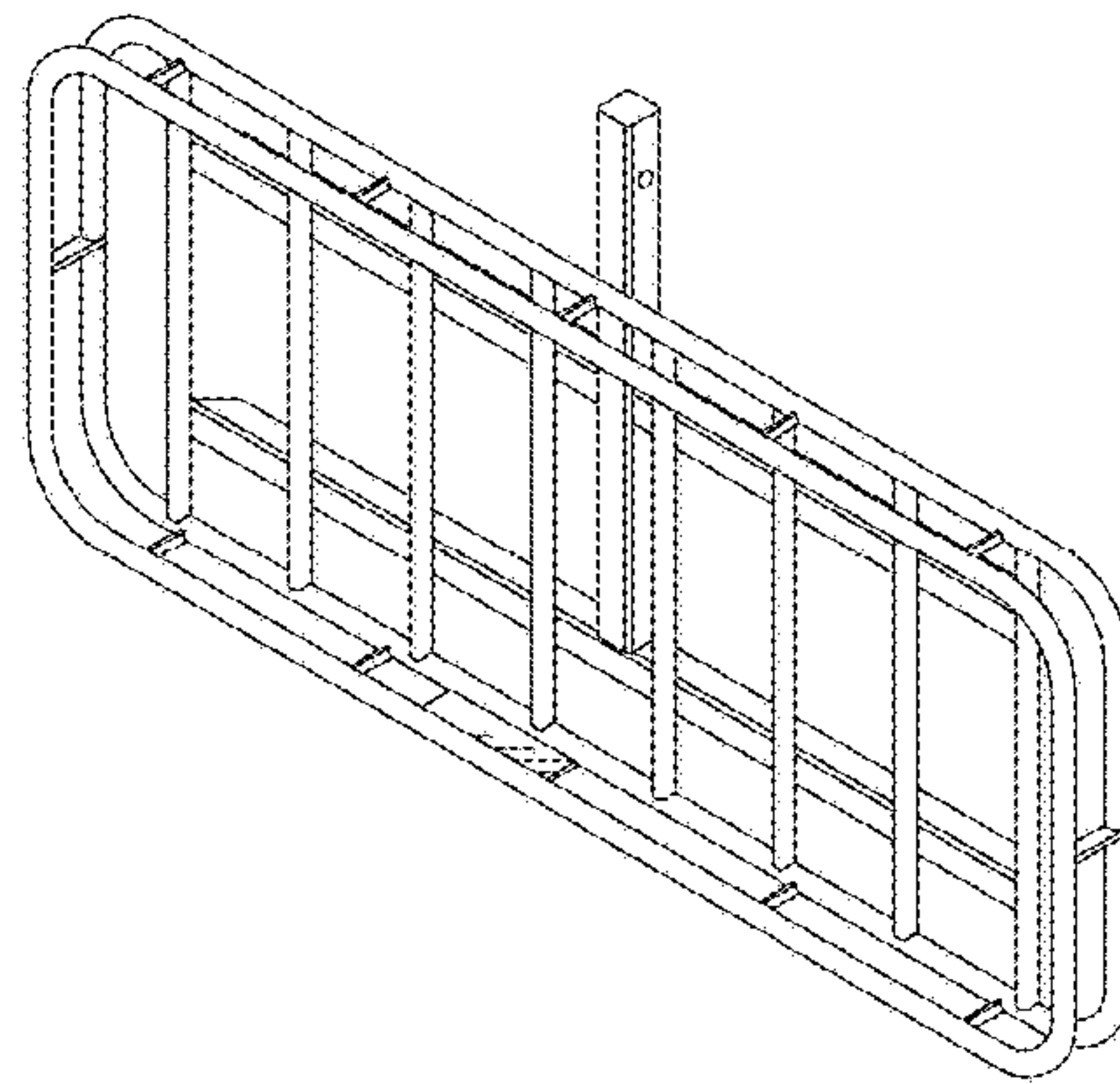

FIG. 11

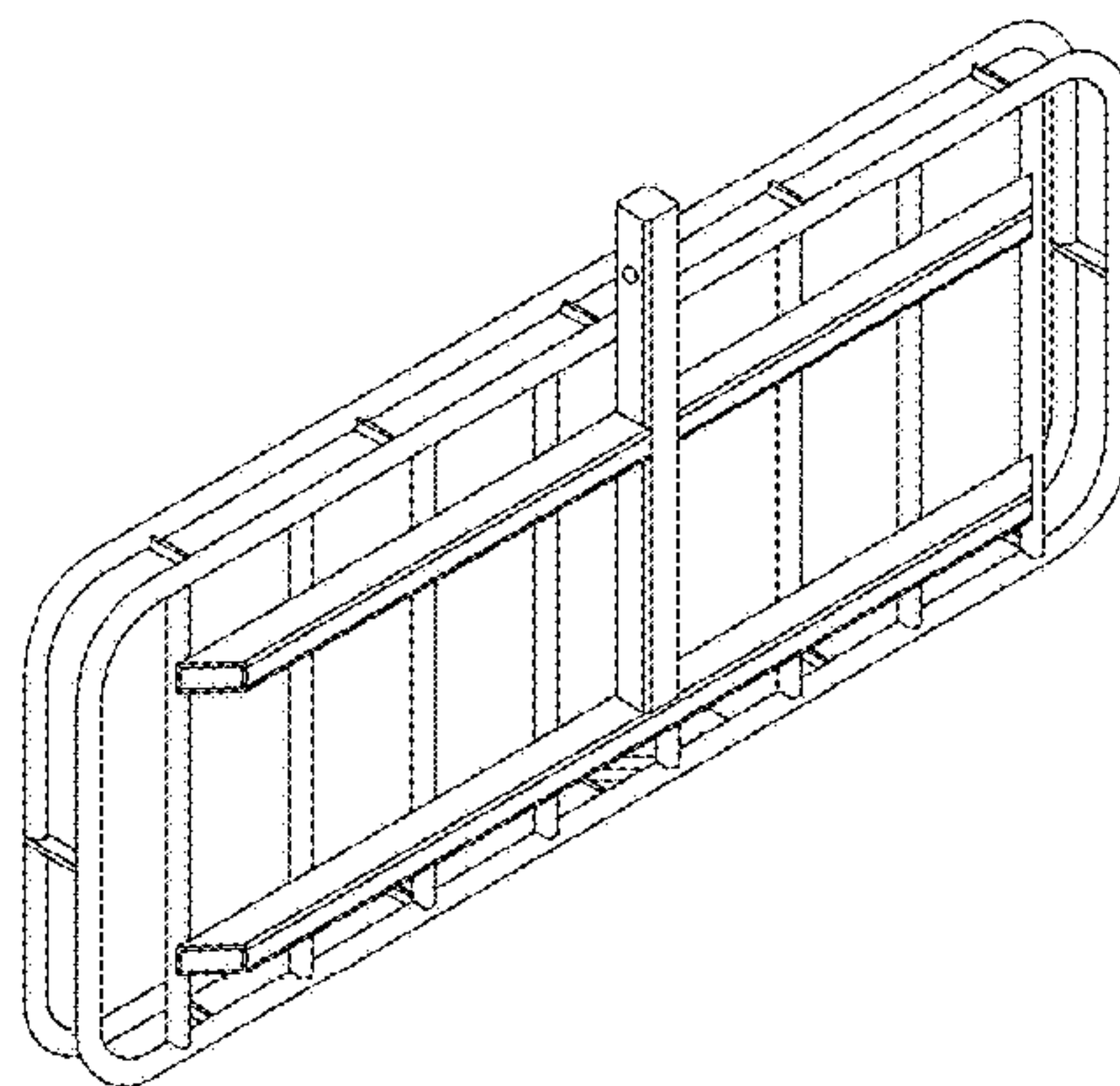

FIG. 12

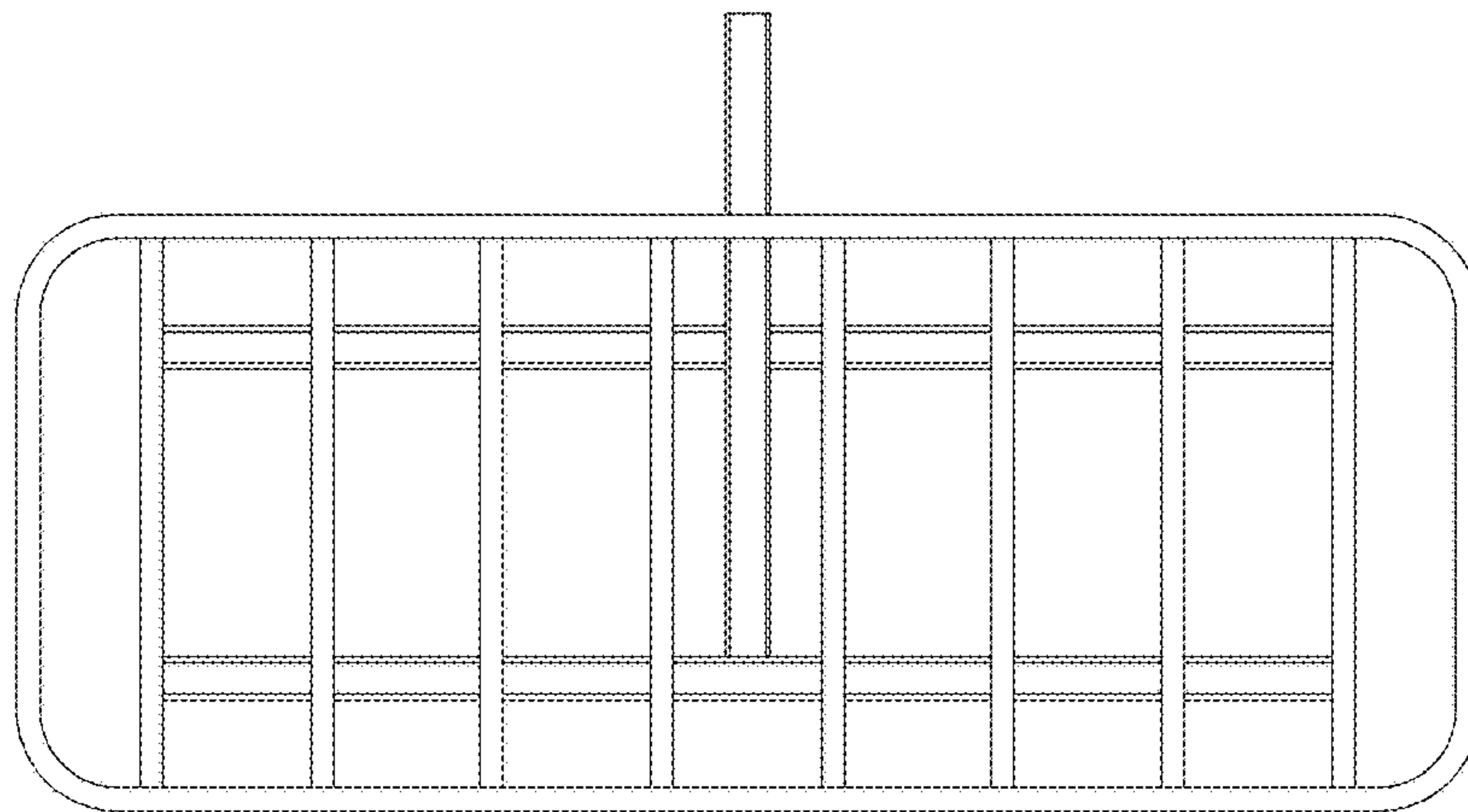

FIG. 13

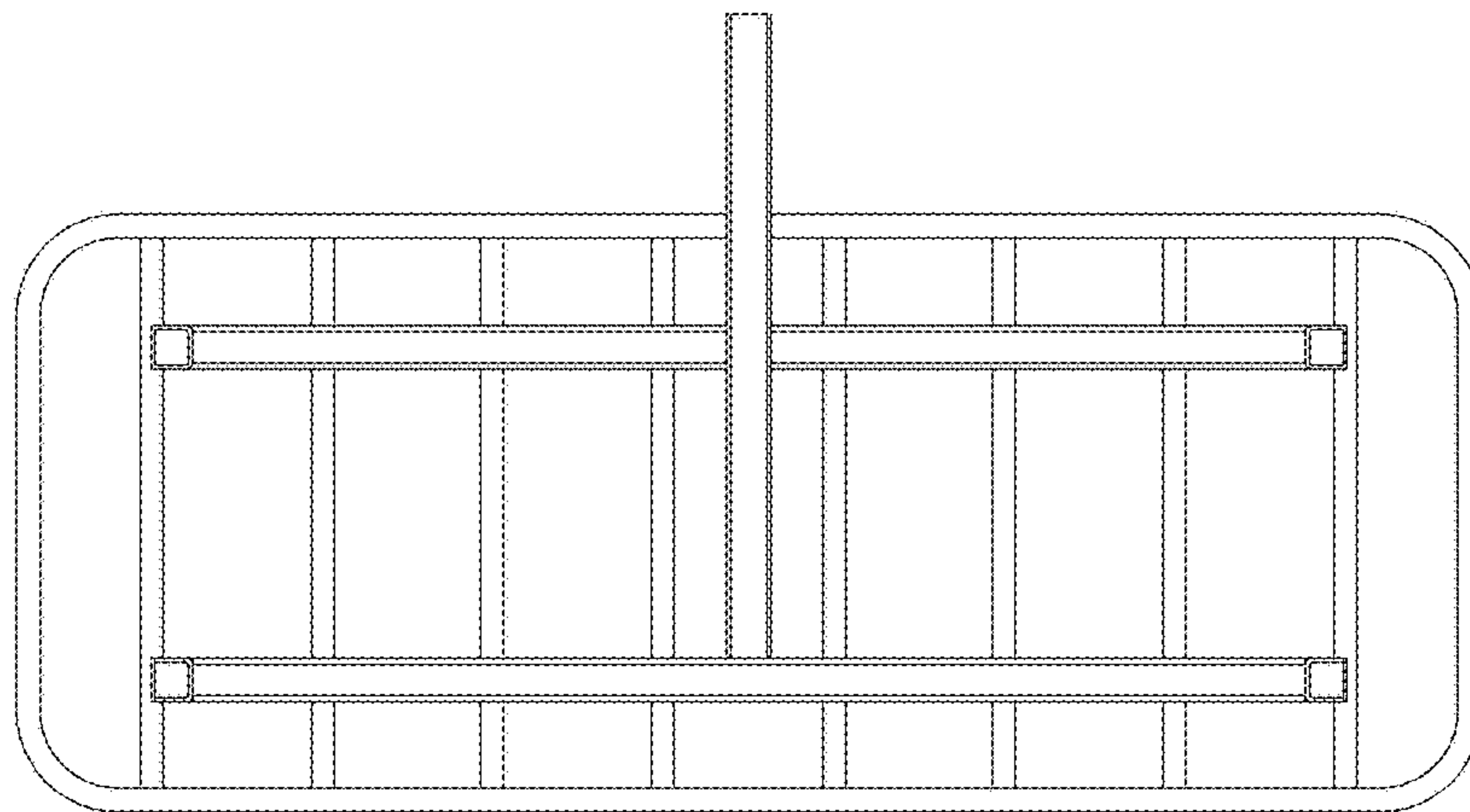

FIG. 14

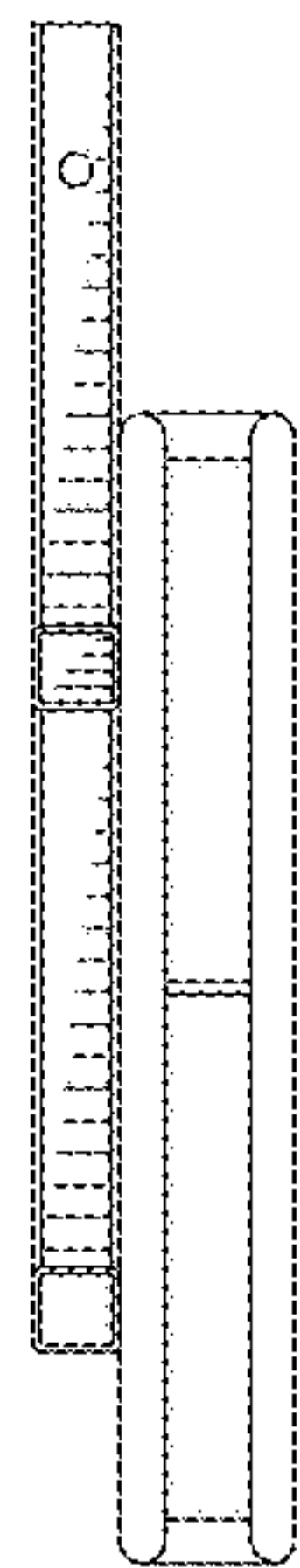

FIG. 15

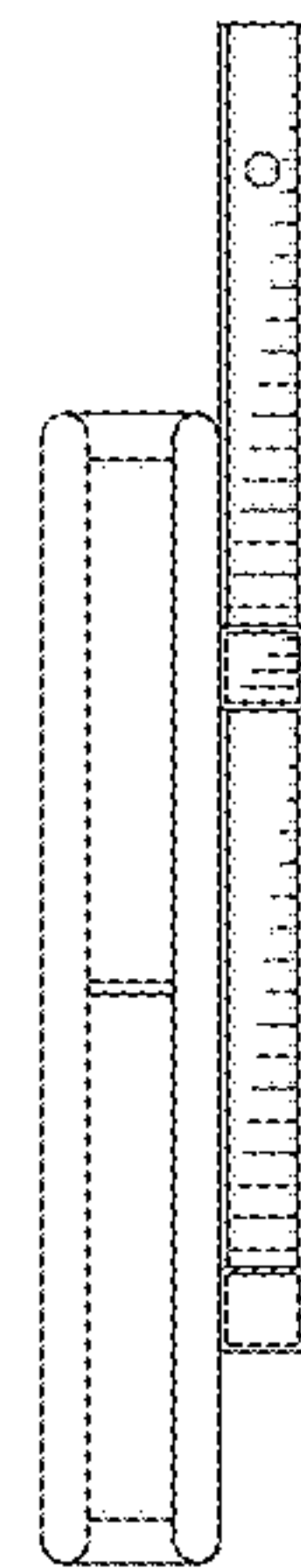

FIG. 16

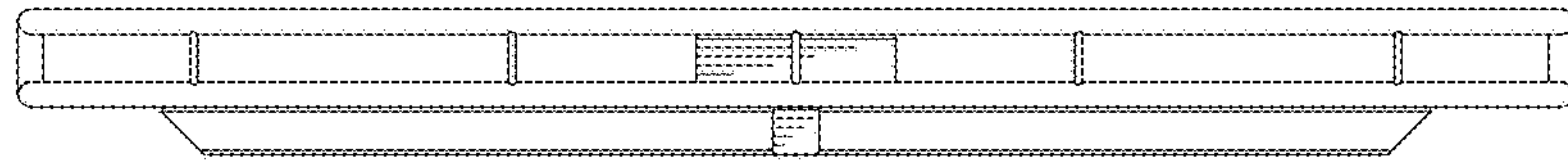

FIG. 17

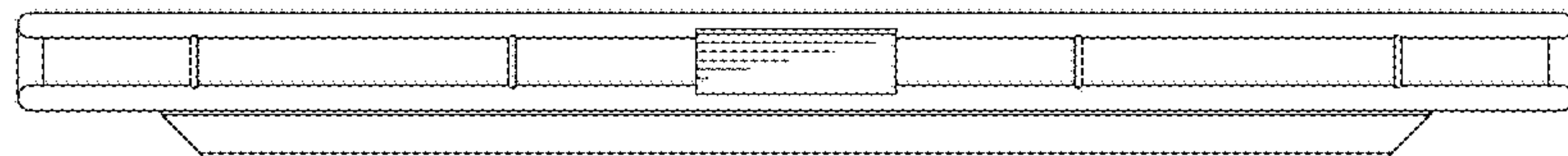

FIG. 18