



US00D841305S

(12) **United States Design Patent** (10) **Patent No.:** **US D841,305 S**
Holmes (45) **Date of Patent:** **** Feb. 26, 2019**

- (54) **SHOE UPPER**
- (71) Applicant: **NIKE, Inc.**, Beaverton, OR (US)
- (72) Inventor: **Edmund Holmes**, Portland, OR (US)
- (73) Assignee: **NIKE, Inc.**, Beaverton, OR (US)
- (**) Term: **15 Years**
- (21) Appl. No.: **29/626,016**
- (22) Filed: **Nov. 14, 2017**
- (51) **LOC (11) Cl.** **02-04**
- (52) **U.S. Cl.**
USPC **D2/972**
- (58) **Field of Classification Search**
USPC D2/896-900, 902-907, 909-911, 923,
D2/943, 946, 969, 970, 972
CPC A43B 3/10; A43B 3/16; A43B 23/00
See application file for complete search history.

- D783,994 S * 4/2017 Chang D2/972
- D802,284 S * 11/2017 McCullagh D2/972
- D829,432 S * 10/2018 Sokol D2/973

* cited by examiner

Primary Examiner — Rashida C. Walshon
(74) *Attorney, Agent, or Firm* — Shook, Hardy and Bacon L.L.P.

(57) **CLAIM**

The ornamental design for a shoe upper, as shown and described.

DESCRIPTION

FIG. 1 is a side view of a shoe showing my design; FIG. 2 is a front perspective view thereof; and, FIG. 3 is a rear perspective view thereof. The long-and-short broken lines form an unclaimed boundary around at least a portion of the claimed subject matter, and form no part of the claim. The even-length broken lines, which show the remainder of the article, are directed to environment, represent unclaimed subject matter, and form no part of the claimed design. The contrast in shading within the claimed boundary represents a contrast in appearance only.

1 Claim, 3 Drawing Sheets

- (56) **References Cited**
U.S. PATENT DOCUMENTS
D641,968 S * 7/2011 Miner D2/972
D653,439 S * 2/2012 Hatfield D2/972
D683,124 S * 5/2013 Raasch D2/972
D696,846 S * 1/2014 Klug D2/972
D707,946 S * 7/2014 Avar D2/972

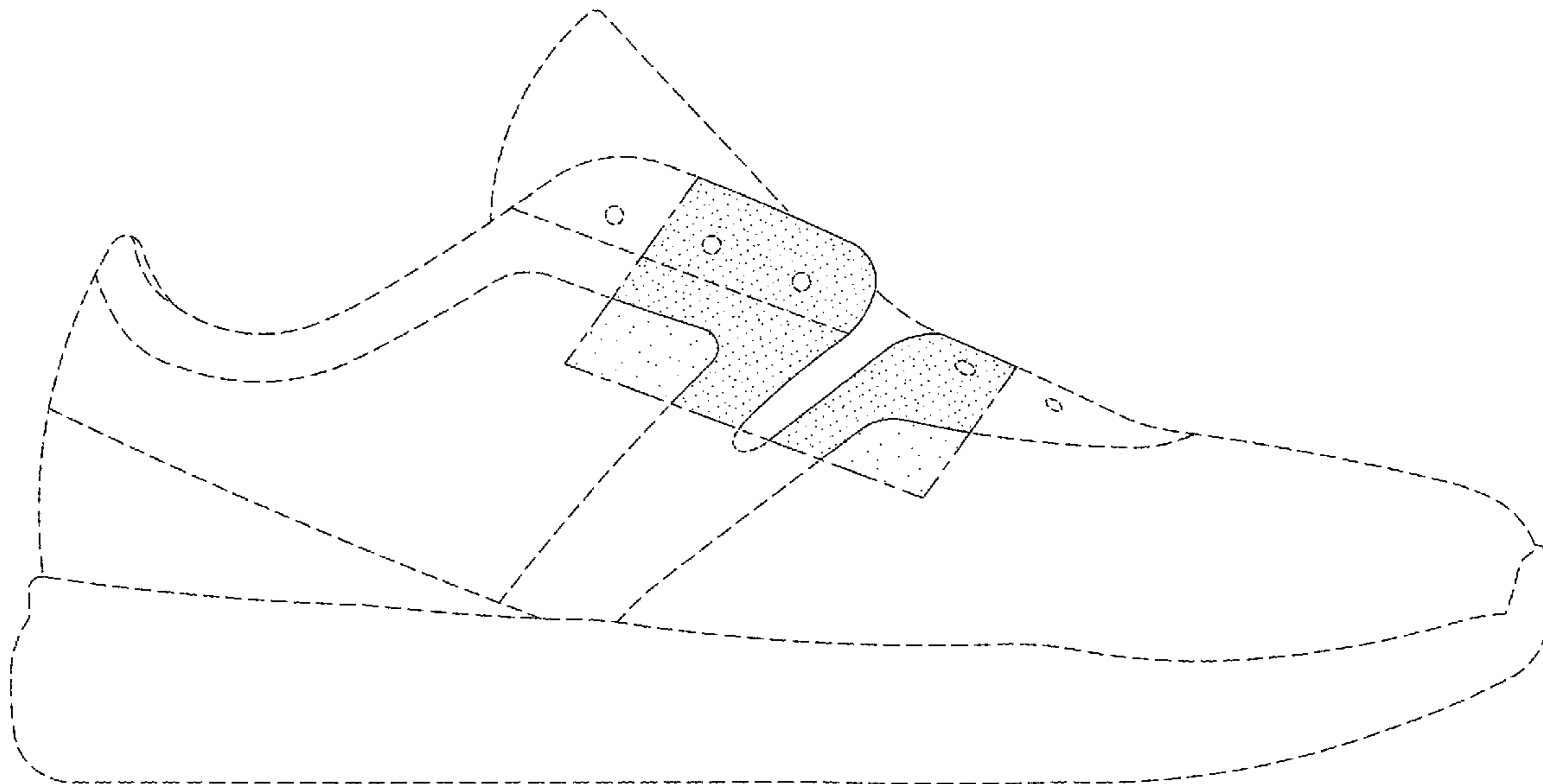

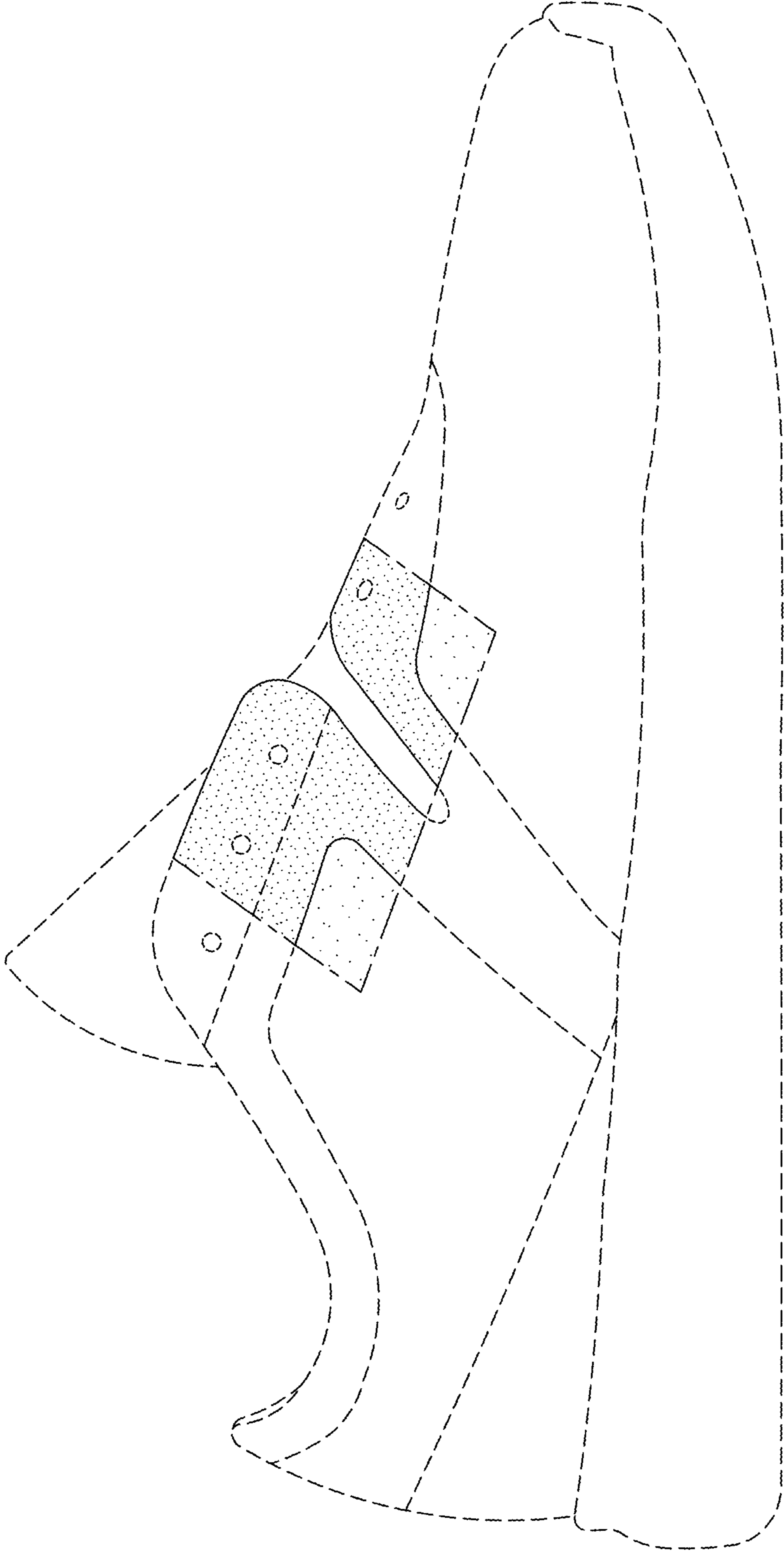

FIG. 1

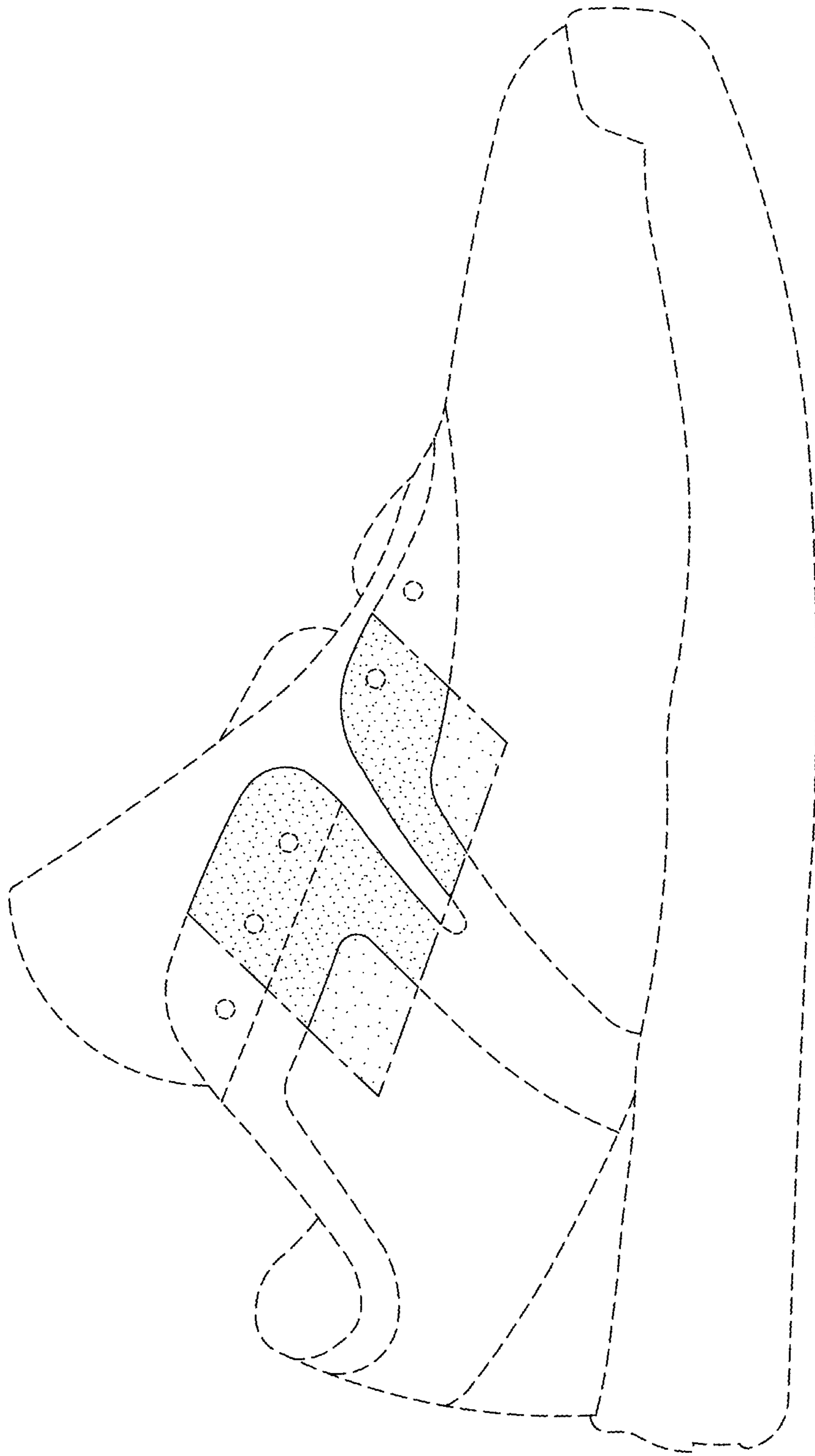

FIG. 2

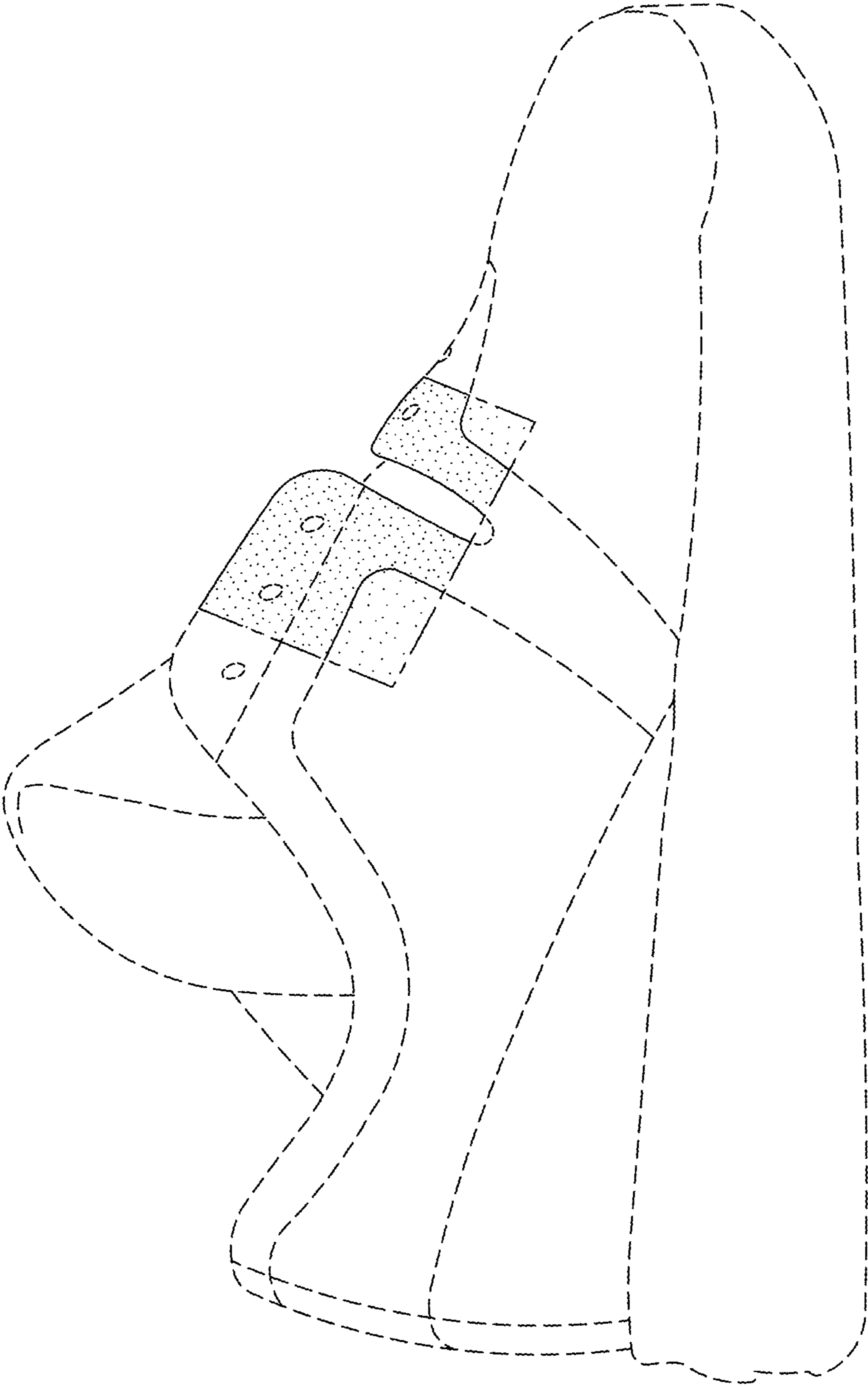

FIG. 3