



US00D841069S

(12) **United States Design Patent**
Ihara

(10) **Patent No.:** **US D841,069 S**

(45) **Date of Patent:** **** Feb. 19, 2019**

(54) **INFRARED MICROSCOPE**

(71) Applicant: **SHIMADZU CORPORATION**, Kyoto (JP)

(72) Inventor: **Kaoru Ihara**, Kyoto (JP)

(73) Assignee: **SHIMADZU CORPORATION**, Kyoto (JP)

(**) Term: **15 Years**

(21) Appl. No.: **29/566,423**

(22) Filed: **May 31, 2016**

(30) **Foreign Application Priority Data**

Feb. 2, 2016 (JP) 2016-002179

(51) **LOC (11) Cl.** **16-06**

(52) **U.S. Cl.**
USPC **D16/131**

(58) **Field of Classification Search**
USPC D18/50; D24/216; D14/125; D10/75,
D10/81; D16/130-136, 225
CPC .. G02B 21/008; G02B 21/0088; G02B 21/20;
G02B 21/22; G02B 21/24
See application file for complete search history.

(56) **References Cited**

U.S. PATENT DOCUMENTS

D387,080 S *	12/1997	Miyazawa	D16/225
D392,303 S *	3/1998	Hern	D14/125
D527,464 S *	8/2006	Ina	D24/216
D622,760 S *	8/2010	Kimura	D18/50
D657,407 S *	4/2012	Okamoto	D16/131
D663,338 S *	7/2012	Okamoto	D16/131
D674,830 S *	1/2013	Stoiakine	D16/131
D681,089 S *	4/2013	Au	D16/131
D687,475 S *	8/2013	Oonuma	D16/131
D690,341 S *	9/2013	Tsuda	D16/131
D690,754 S *	10/2013	Tsuda	D16/131

D708,245 S *	7/2014	Matoba	H01J 37/26 D16/131
D711,950 S *	8/2014	Matoba	D16/131
D731,910 S *	6/2015	Muraoka	D10/81
D759,517 S *	6/2016	Kawai	D10/75

(Continued)

OTHER PUBLICATIONS

Infrared Microscope I AIM-9000 Infrared Microscope I Shimadzu, posted date May 12, 2016, (c) 2017 Shimadzu.com [online], [site visited Aug. 30, 2017], Available at <http://www.shimadzu.com/news/c-od0gjn0000004mvi.html>.*

Primary Examiner — Manpreet S Matharu

Assistant Examiner — Holly E Thurman

(74) *Attorney, Agent, or Firm* — JCIPRNET

(57) **CLAIM**

The ornamental design for an infrared microscope, as shown and described.

DESCRIPTION

FIG. 1 is a perspective view of an infrared microscope showing my new design;
FIG. 2 is another perspective view thereof;
FIG. 3 is a front view thereof;
FIG. 4 is a rear view thereof;
FIG. 5 is a left side view thereof;
FIG. 6 is a right side view thereof;
FIG. 7 is a top view thereof; and
FIG. 8 is a bottom view thereof;
FIG. 9 is a cross-section view thereof, taken along the line 9-9 of FIG. 3;
FIG. 10 is a cross-section view thereof, taken along the line 10-10 of FIG. 3; and,
FIG. 11 is a cross-section view thereof, taken along the line 11-11 of FIG. 3.
The broken lines depict portions of the infrared microscope and form no part of the claimed design.

1 Claim, 11 Drawing Sheets

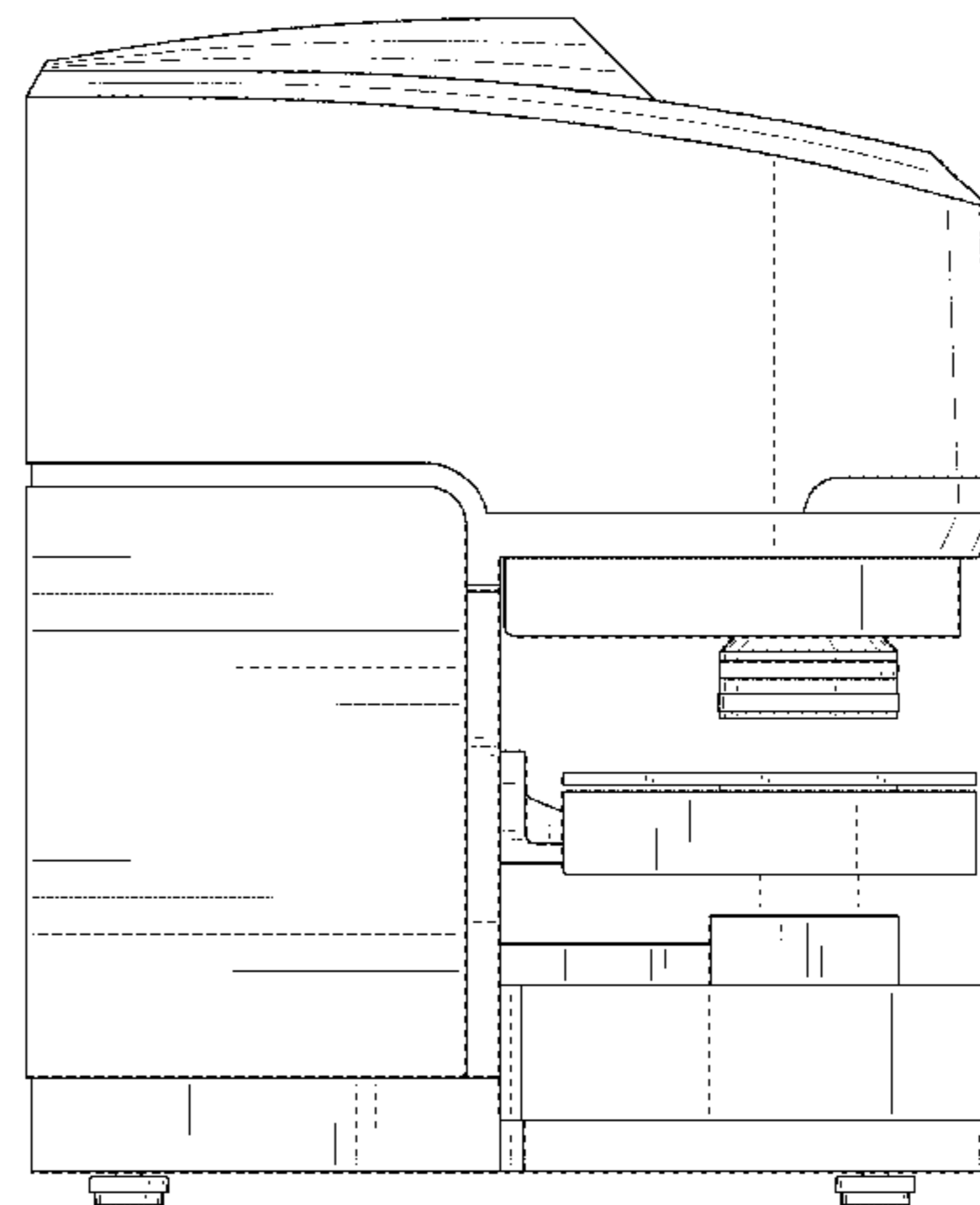
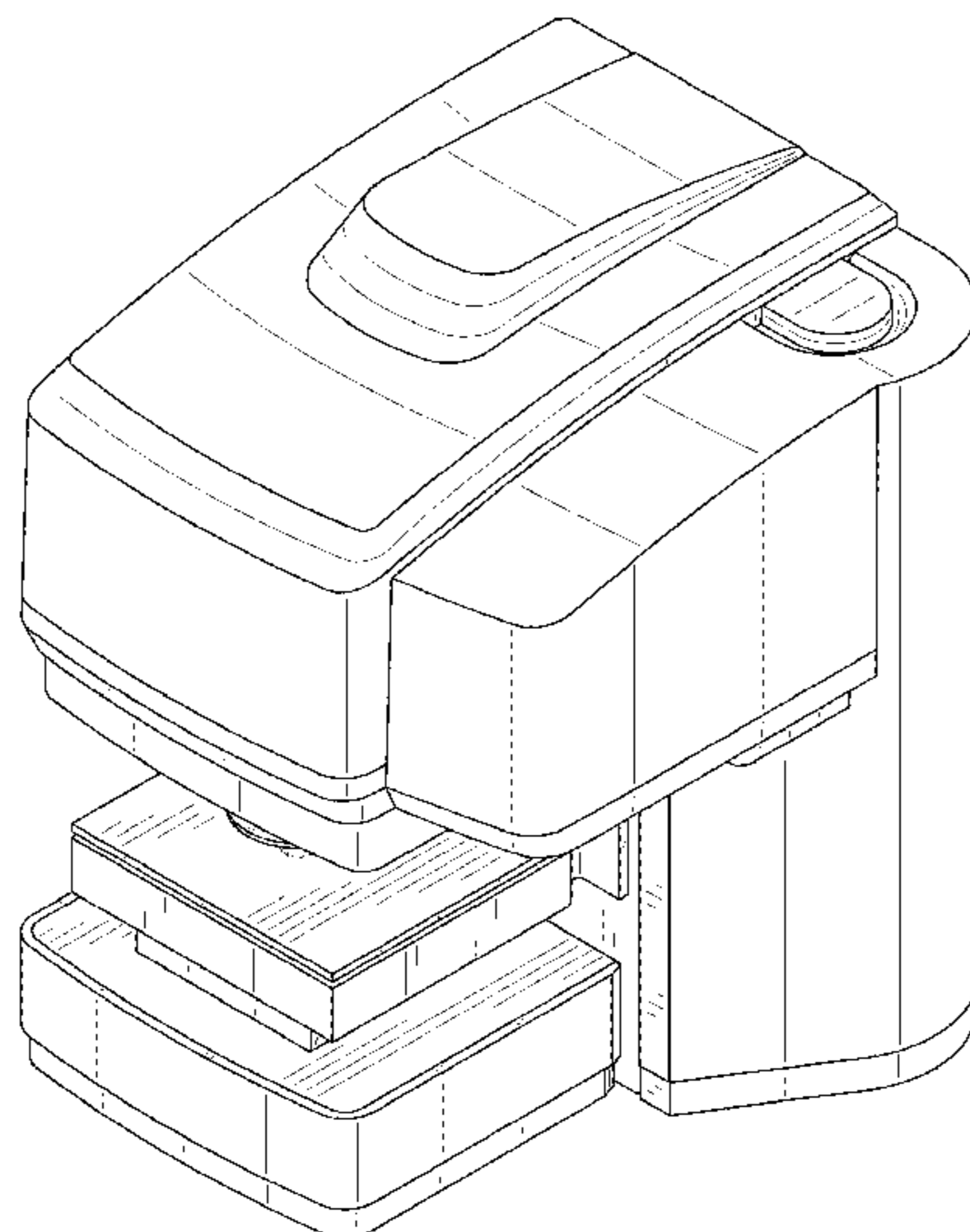

(56)

References Cited

U.S. PATENT DOCUMENTS

D784,433 S * 4/2017 Weber D16/131
D785,690 S * 5/2017 Klein D16/131

* cited by examiner

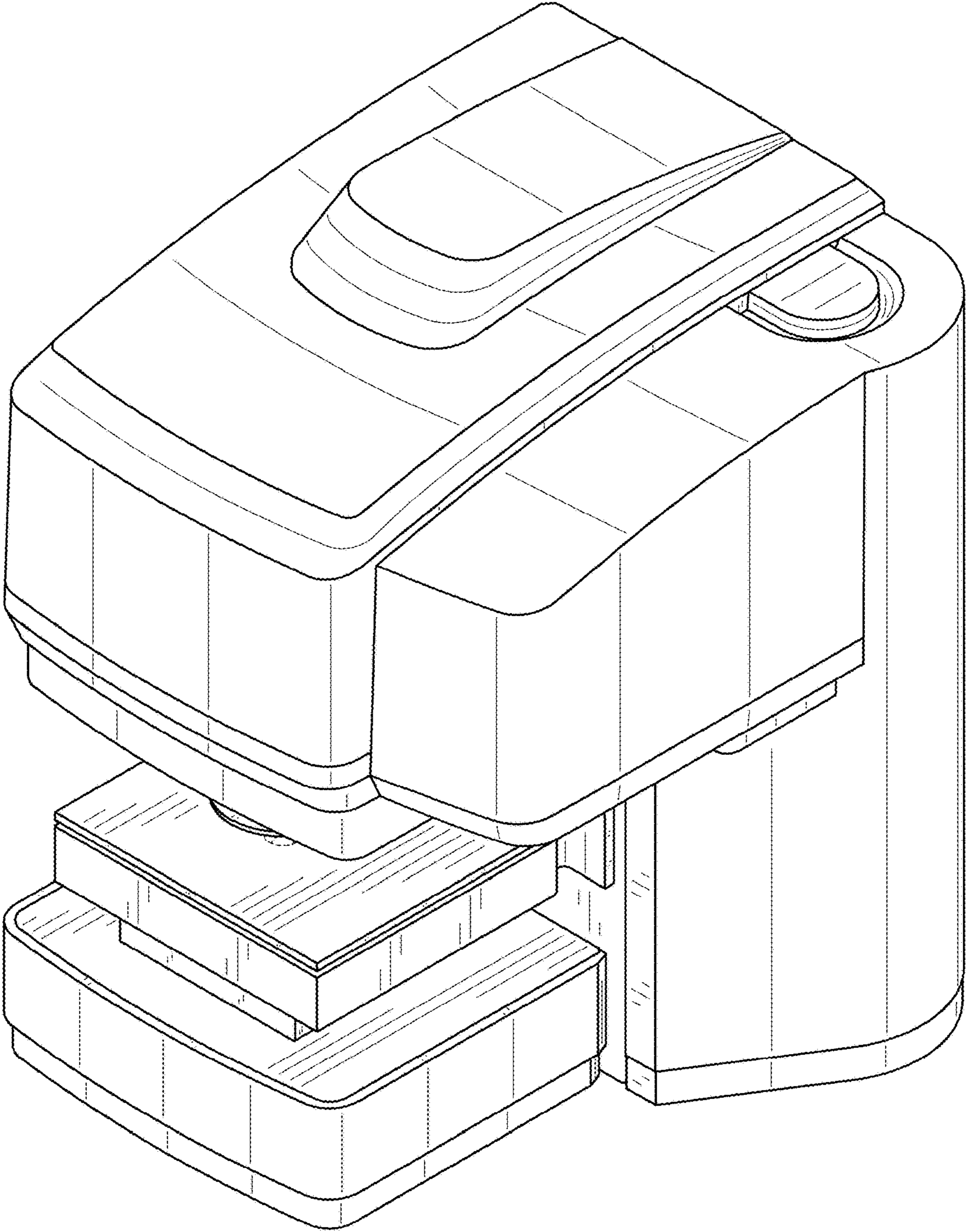

FIG. 1

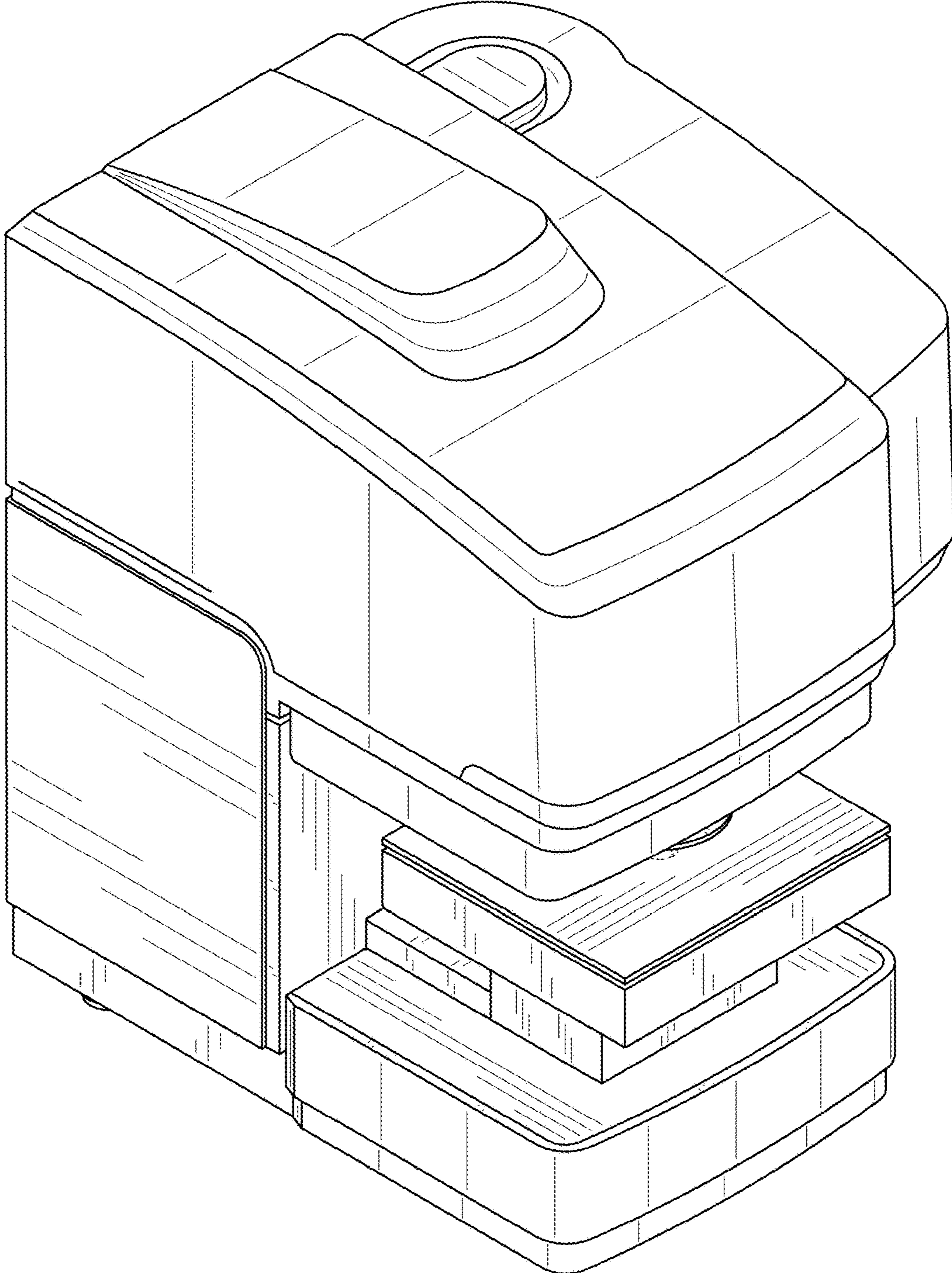

FIG. 2

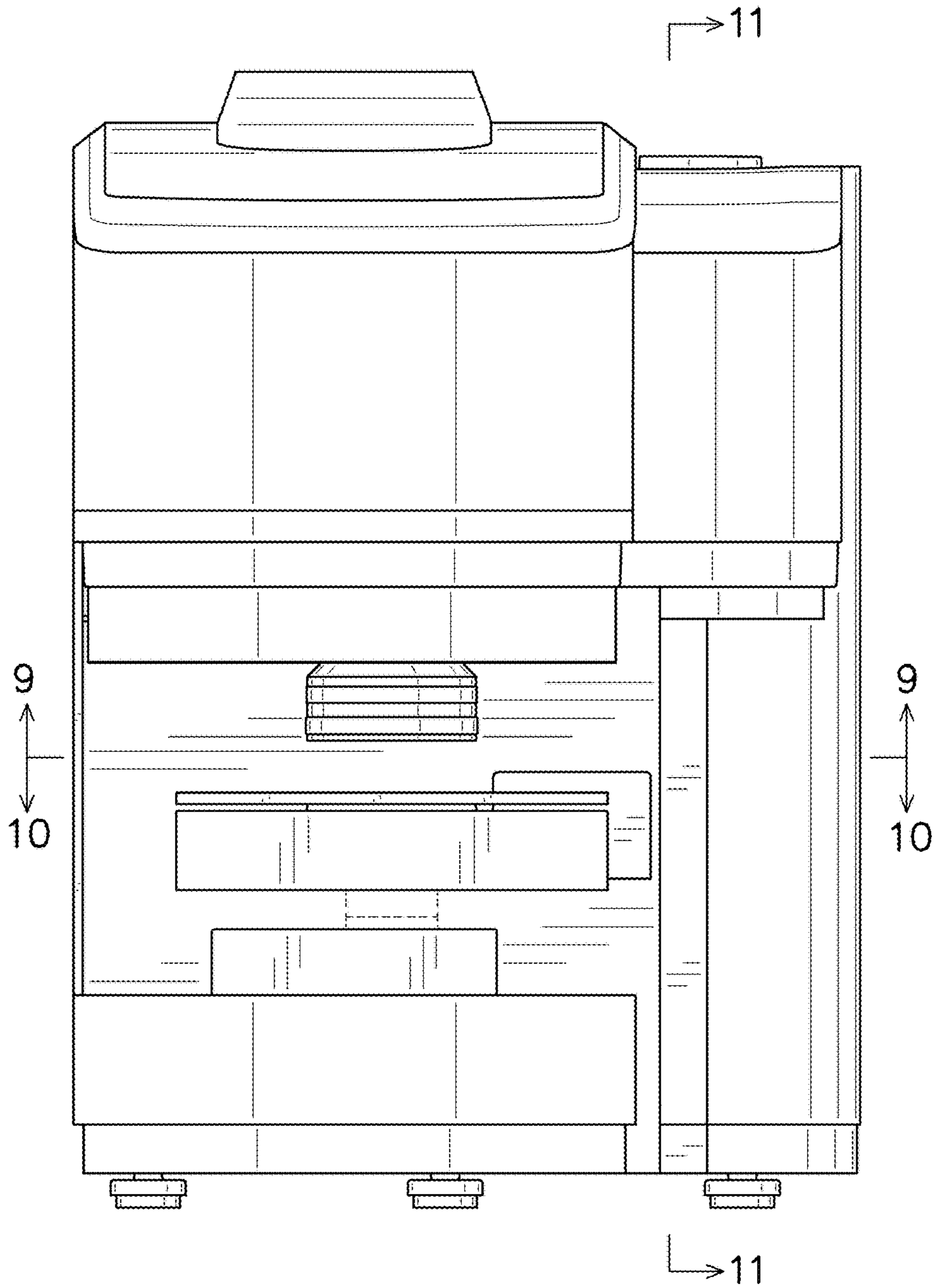

FIG. 3

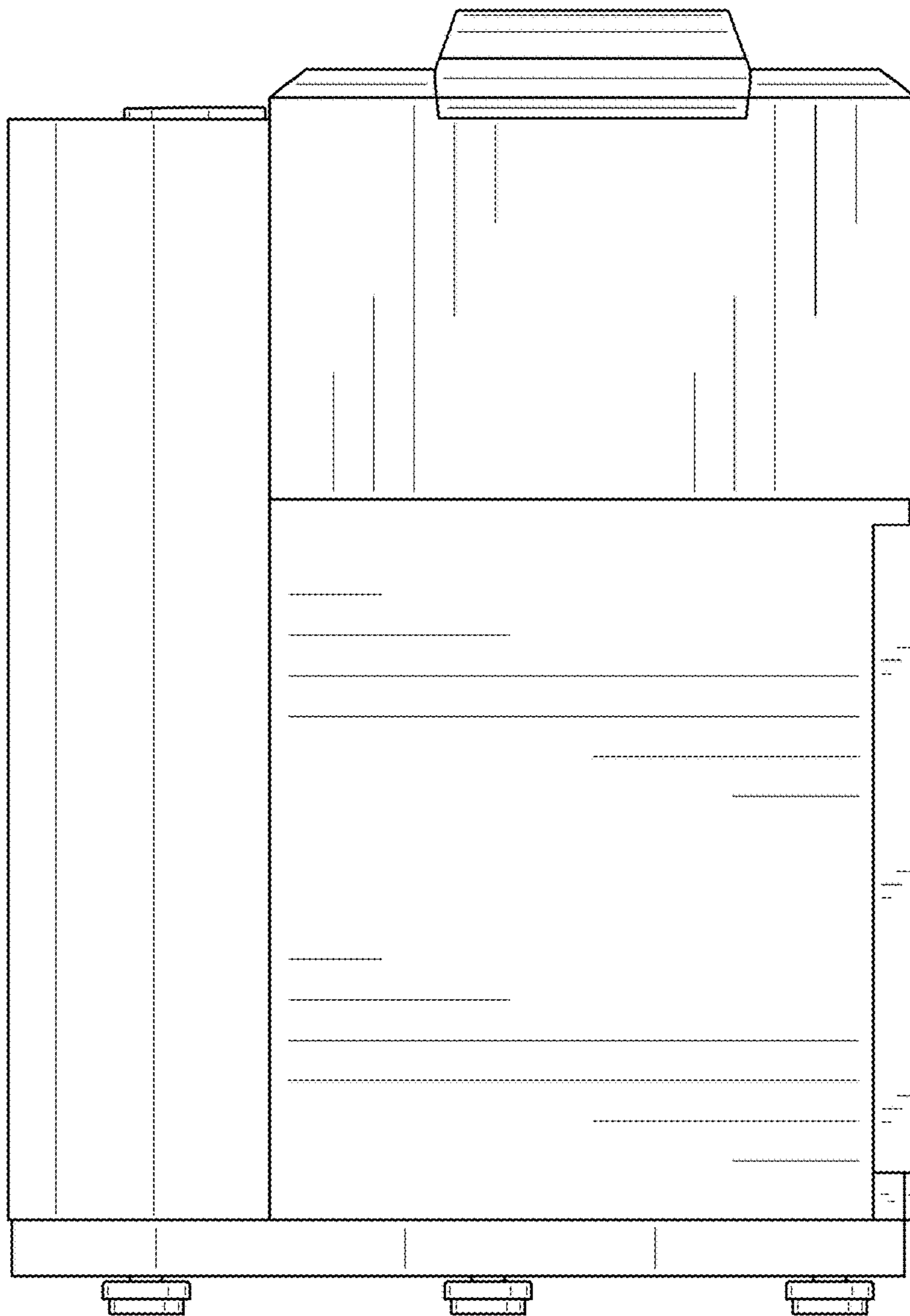

FIG. 4

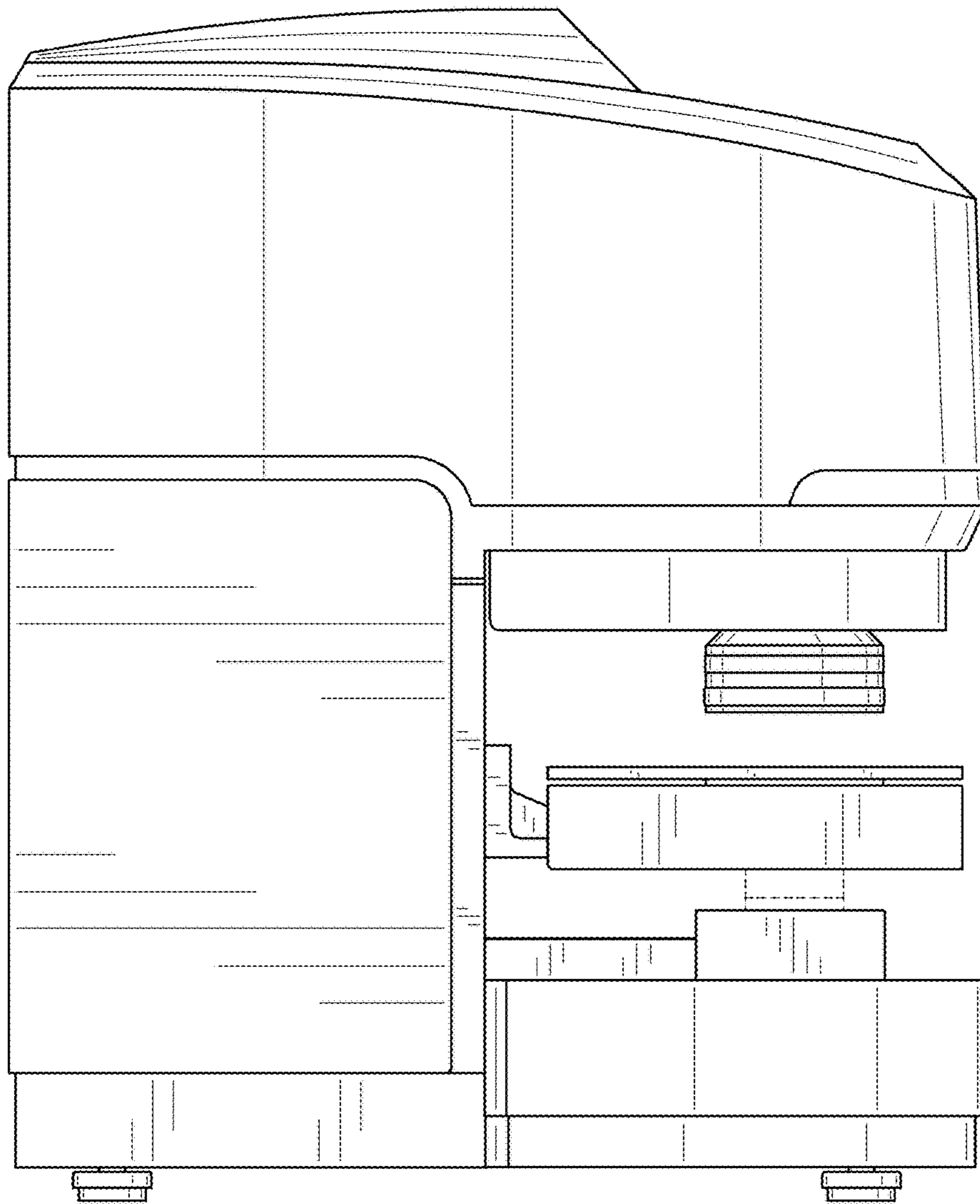

FIG. 5

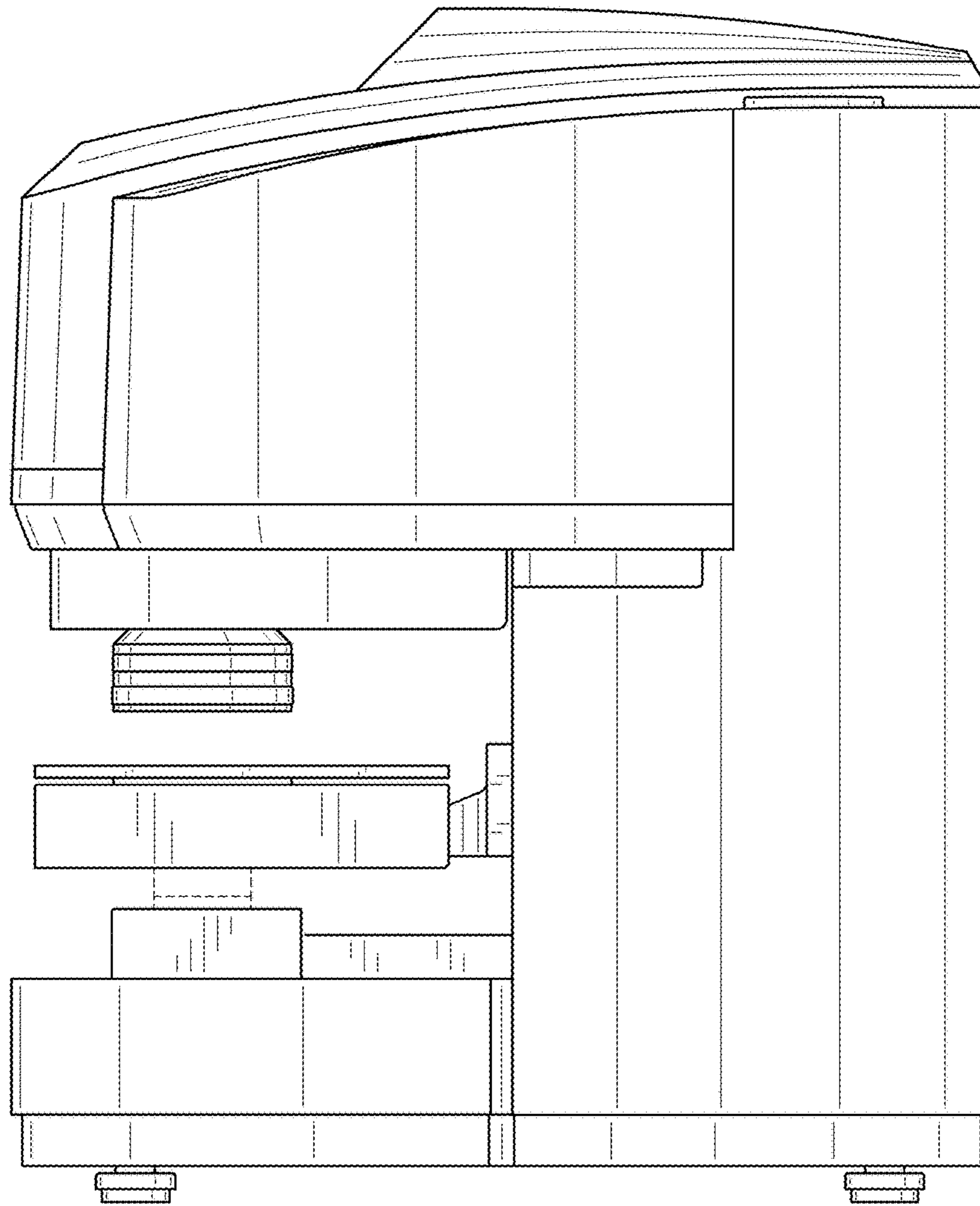

FIG. 6

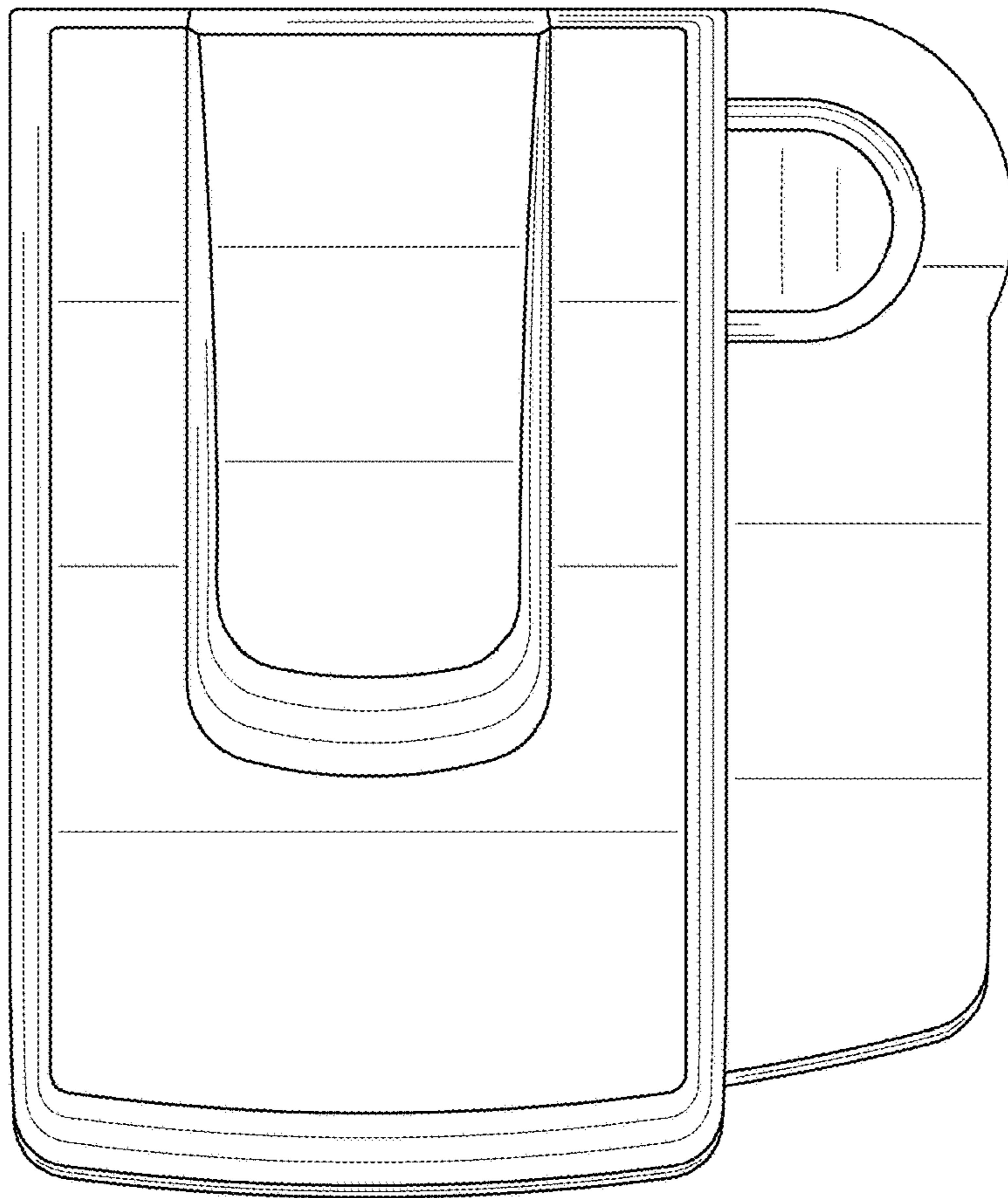

FIG. 7

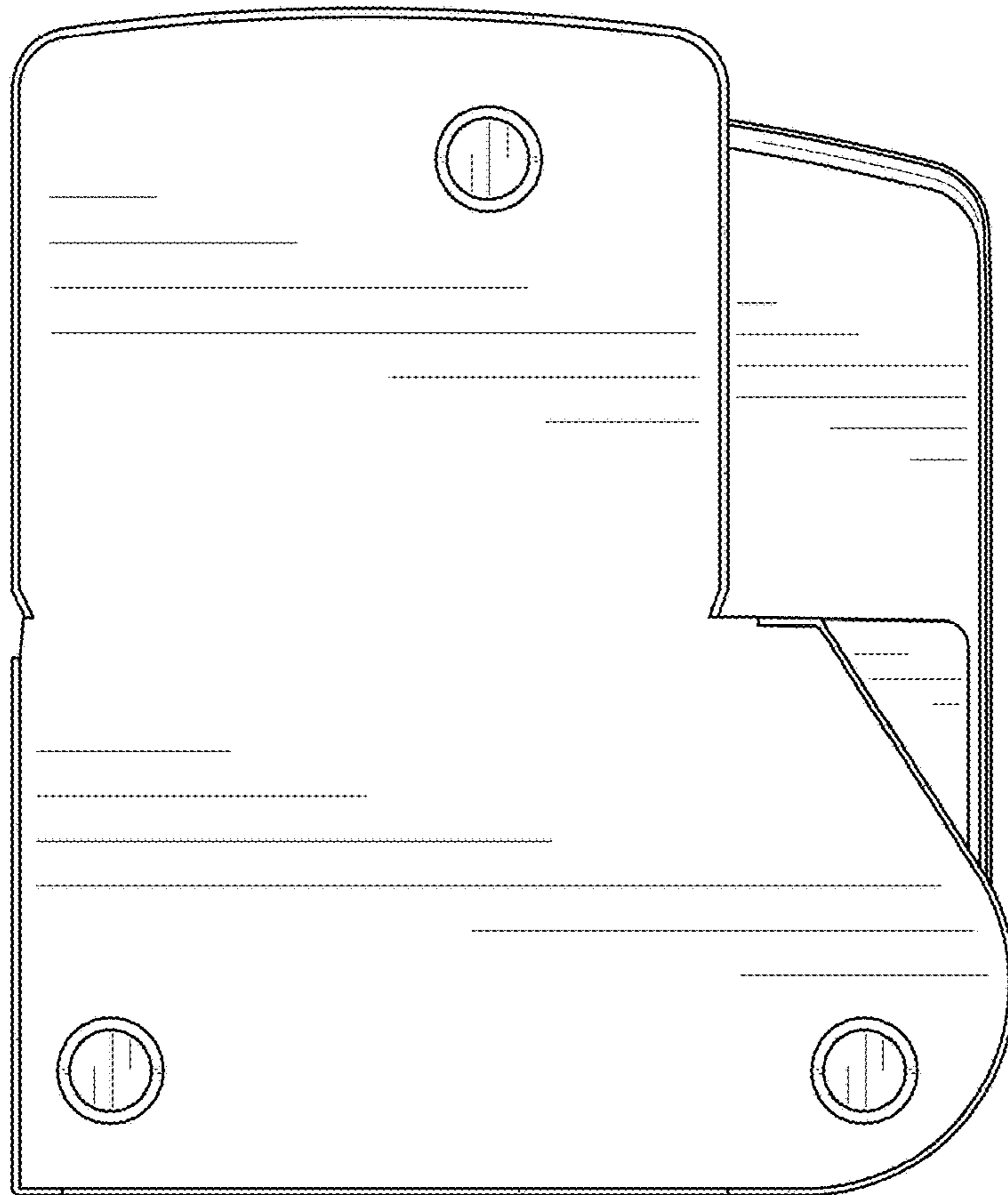

FIG. 8

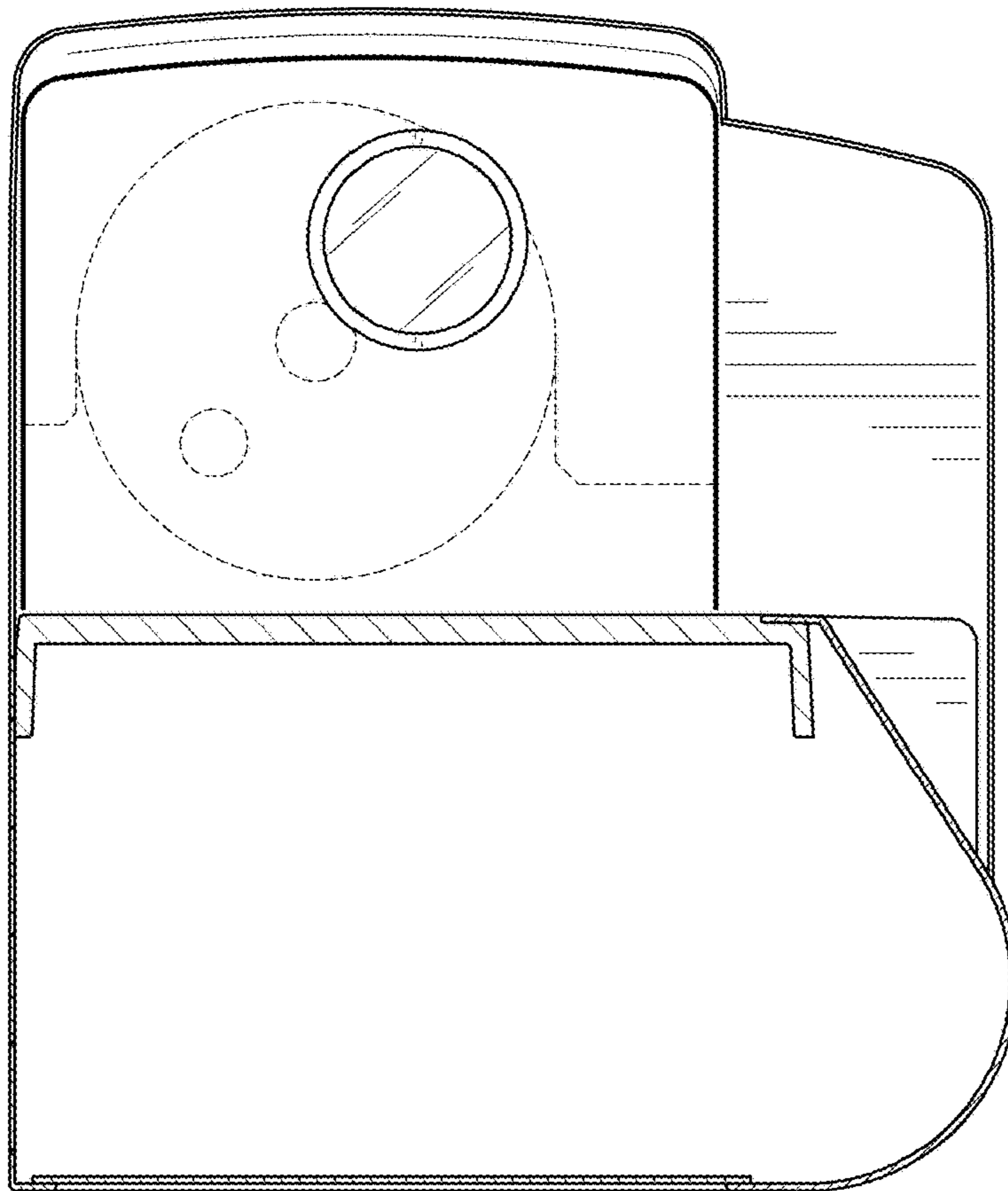

FIG. 9

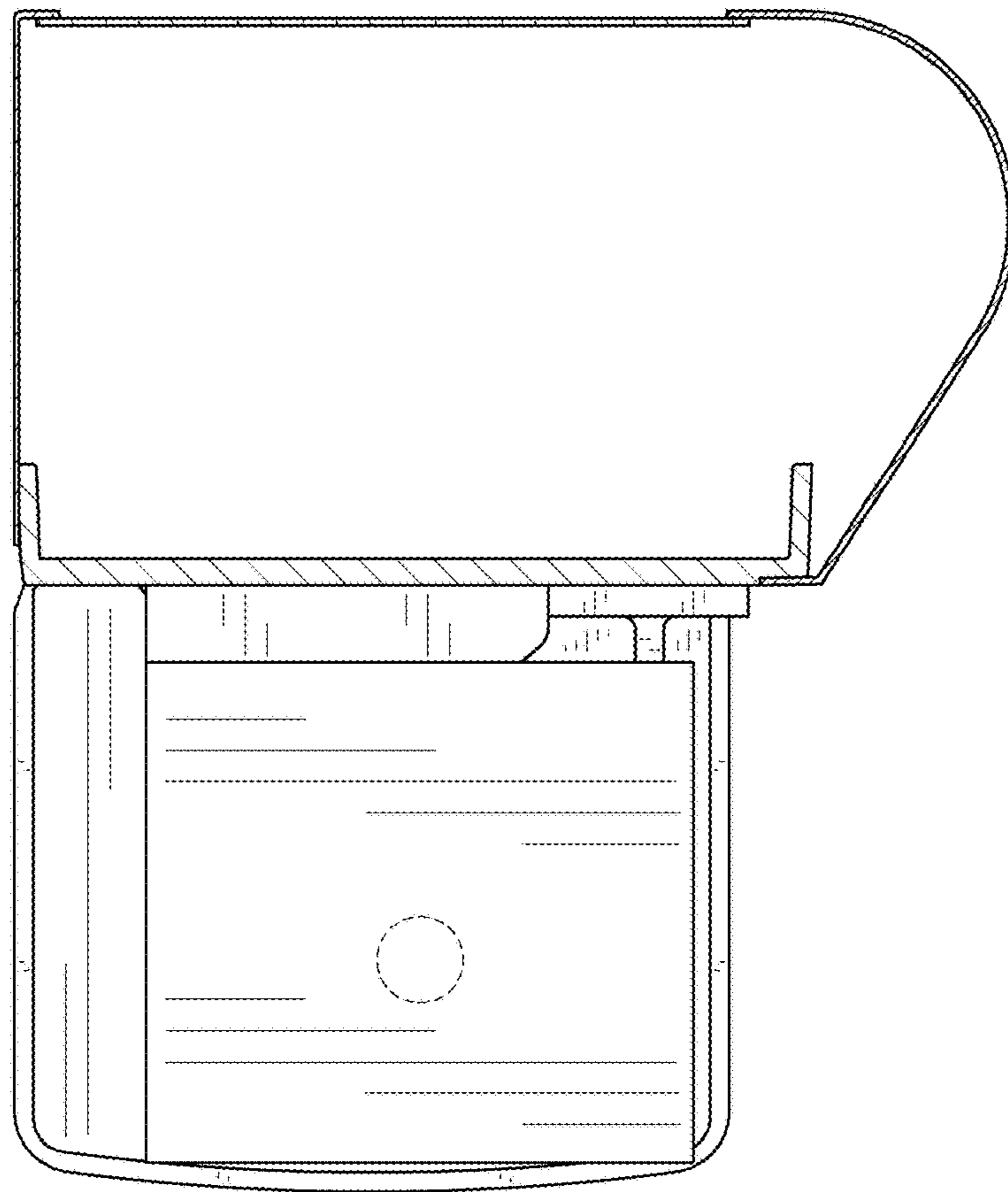

FIG. 10

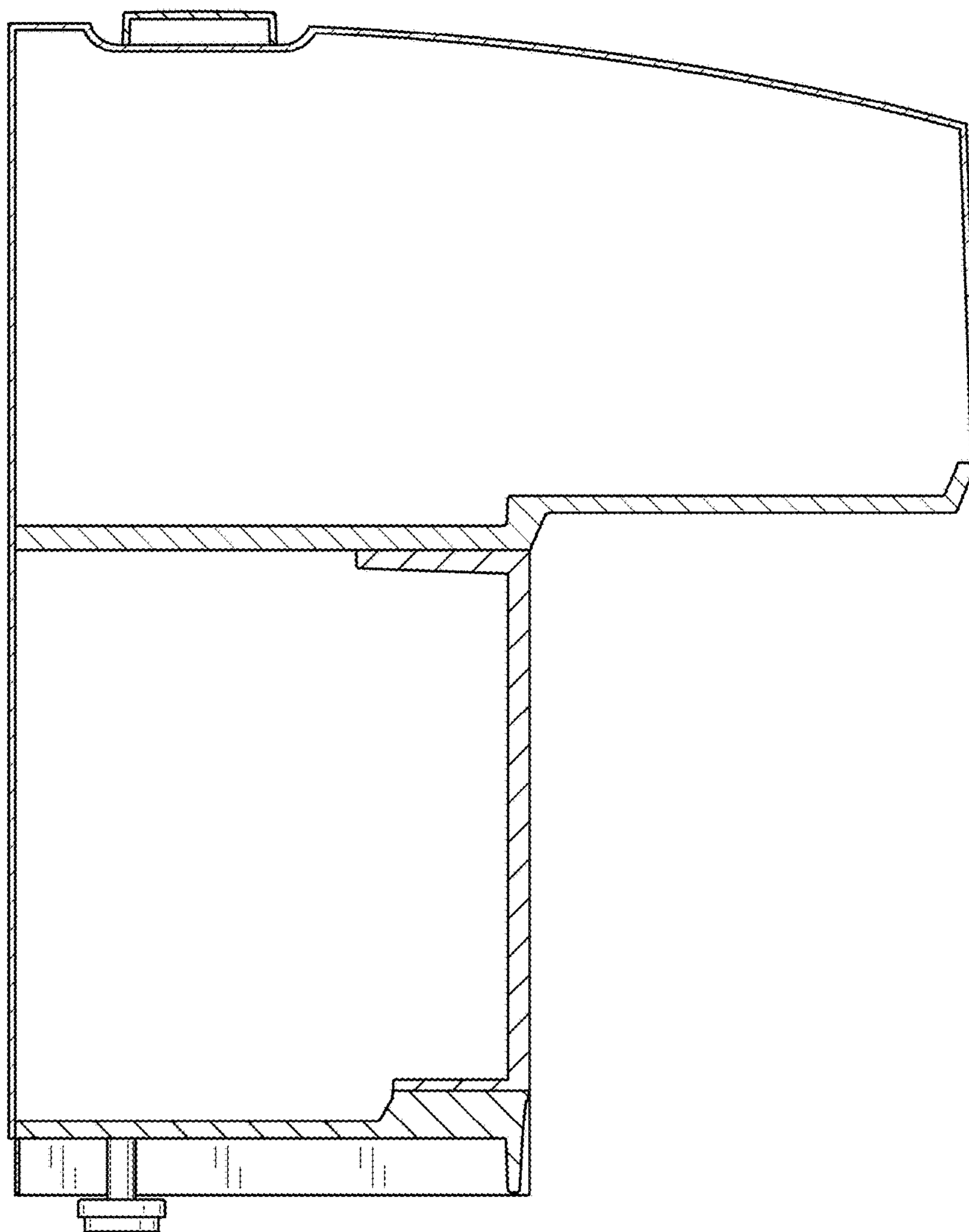

FIG. 11