



US00D840888S

(12) **United States Design Patent**
Takagi

(10) **Patent No.:** **US D840,888 S**

(45) **Date of Patent:** **** Feb. 19, 2019**

(54) **REAR DOOR TRIM PANEL FOR AN
AUTOMOBILE**

(71) Applicant: **Subaru Corporation**, Tokyo (JP)

(72) Inventor: **Souta Takagi**, Tokyo (JP)

(73) Assignee: **Subaru Corporation**, Tokyo (JP)

(**) Term: **15 Years**

(21) Appl. No.: **29/617,273**

(22) Filed: **Sep. 13, 2017**

(30) **Foreign Application Priority Data**

Mar. 13, 2017 (JP) 2017-005052

(51) **LOC (11) Cl.** **12-08**

(52) **U.S. Cl.**
USPC **D12/195**

(58) **Field of Classification Search**
USPC D12/195, 193, 414, 190, 196; D15/17,
D15/28; D10/46, 98, 102-103;
D8/302-303
CPC B60N 2/466; B60N 2/4693; B60J 5/04;
B60R 13/0243

See application file for complete search history.

(56) **References Cited**

U.S. PATENT DOCUMENTS

D784,883 S * 4/2017 Lee D12/195
D801,899 S * 11/2017 Watkin D12/195

D807,267 S * 1/2018 Higashimori D12/195
D814,374 S * 4/2018 Patterson D12/195
D816,571 S * 5/2018 Wiedeman D12/195
D816,572 S * 5/2018 Ma D12/195
D816,573 S * 5/2018 Ma D12/195
D819,534 S * 6/2018 Buffery D12/195
D820,754 S * 6/2018 Buffery D12/195
D823,208 S * 7/2018 Boyes D12/195
D823,760 S * 7/2018 Sato D12/195

* cited by examiner

Primary Examiner — Katrina A Betton

(74) *Attorney, Agent, or Firm* — Schiff Hardin LLP

(57) **CLAIM**

I claim the ornamental design for a rear door trim panel for an automobile, as shown and described.

DESCRIPTION

FIG. 1 is a front perspective view for a “rear door trim panel for an automobile” showing my new design, FIG. 2 is a rear perspective view thereof, FIG. 3 is a front view thereof, FIG. 4 is a rear view thereof, FIG. 5 is a top view thereof, FIG. 6 is a bottom view thereof, FIG. 7 is a left-side view thereof; and, FIG. 8 is a right-side view thereof.

1 Claim, 8 Drawing Sheets

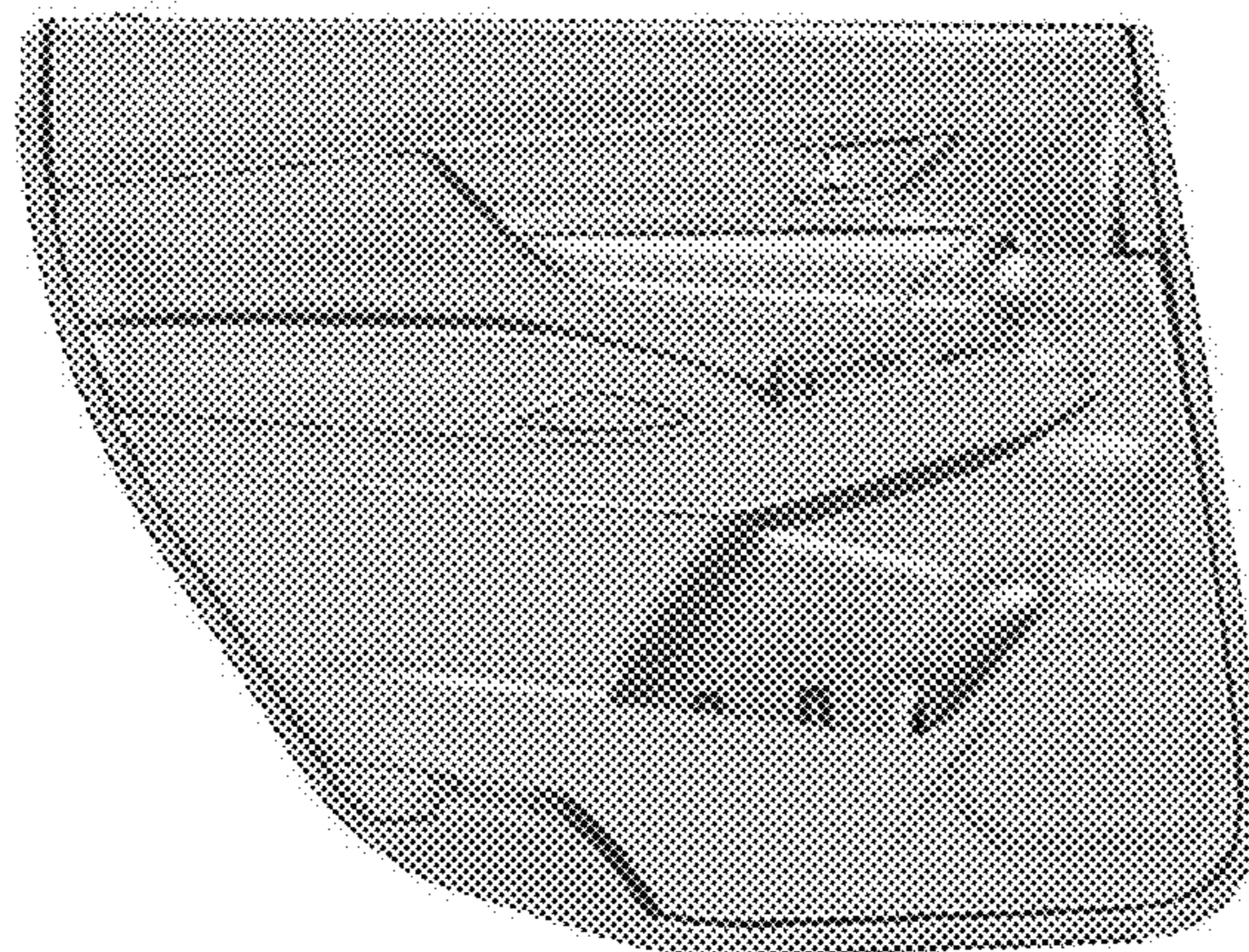

Fig. 1

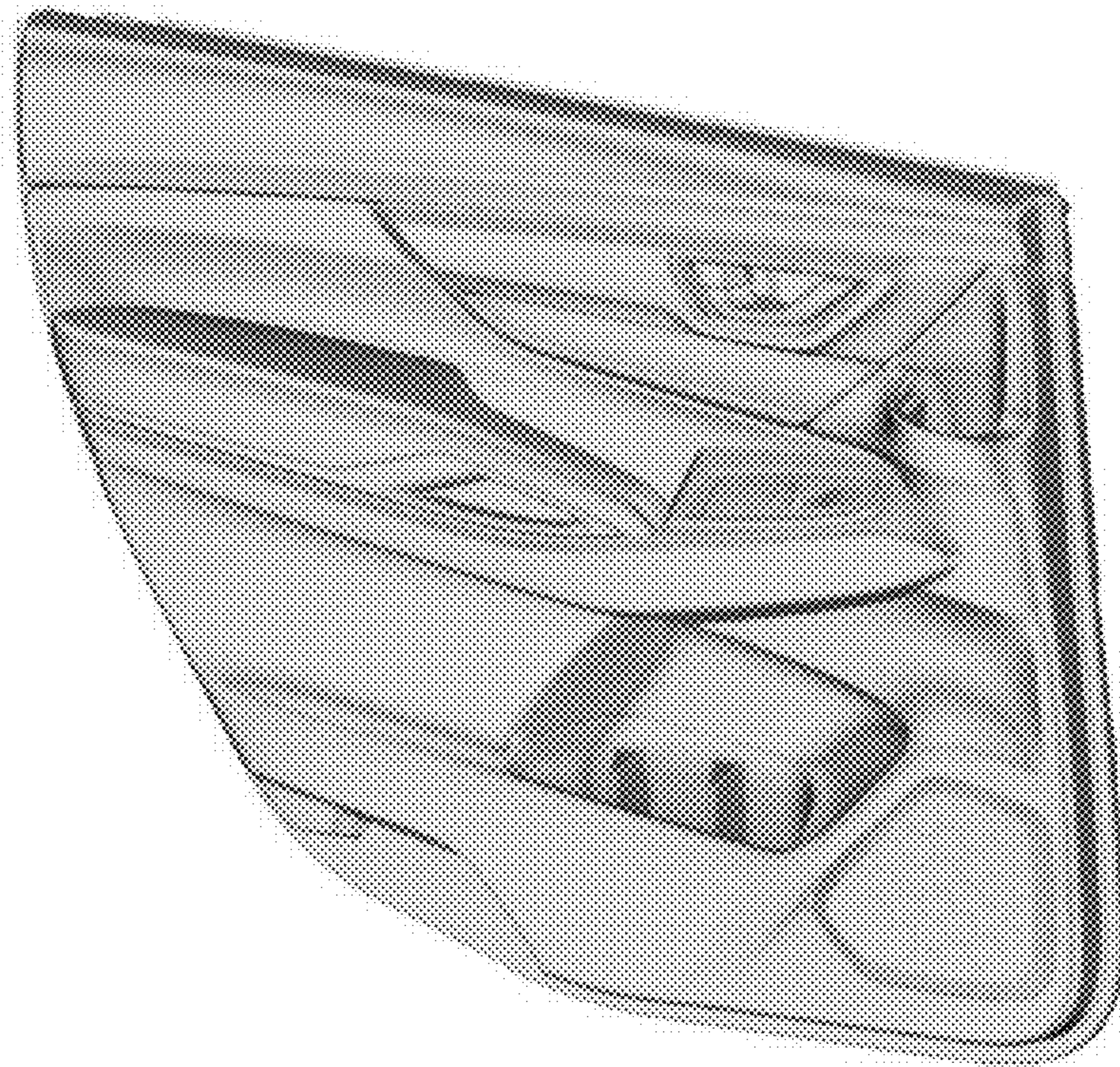

Fig. 2

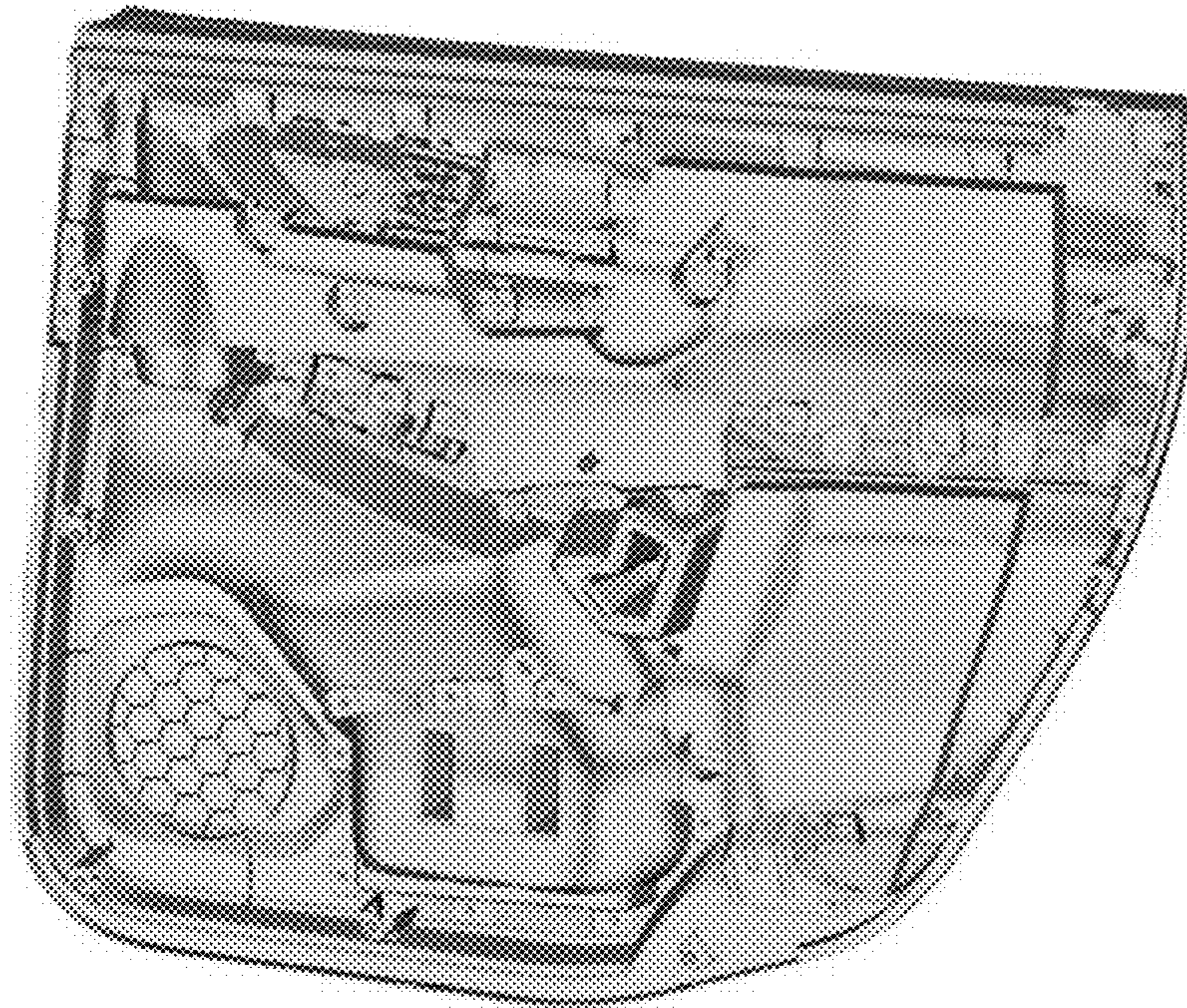

Fig. 3

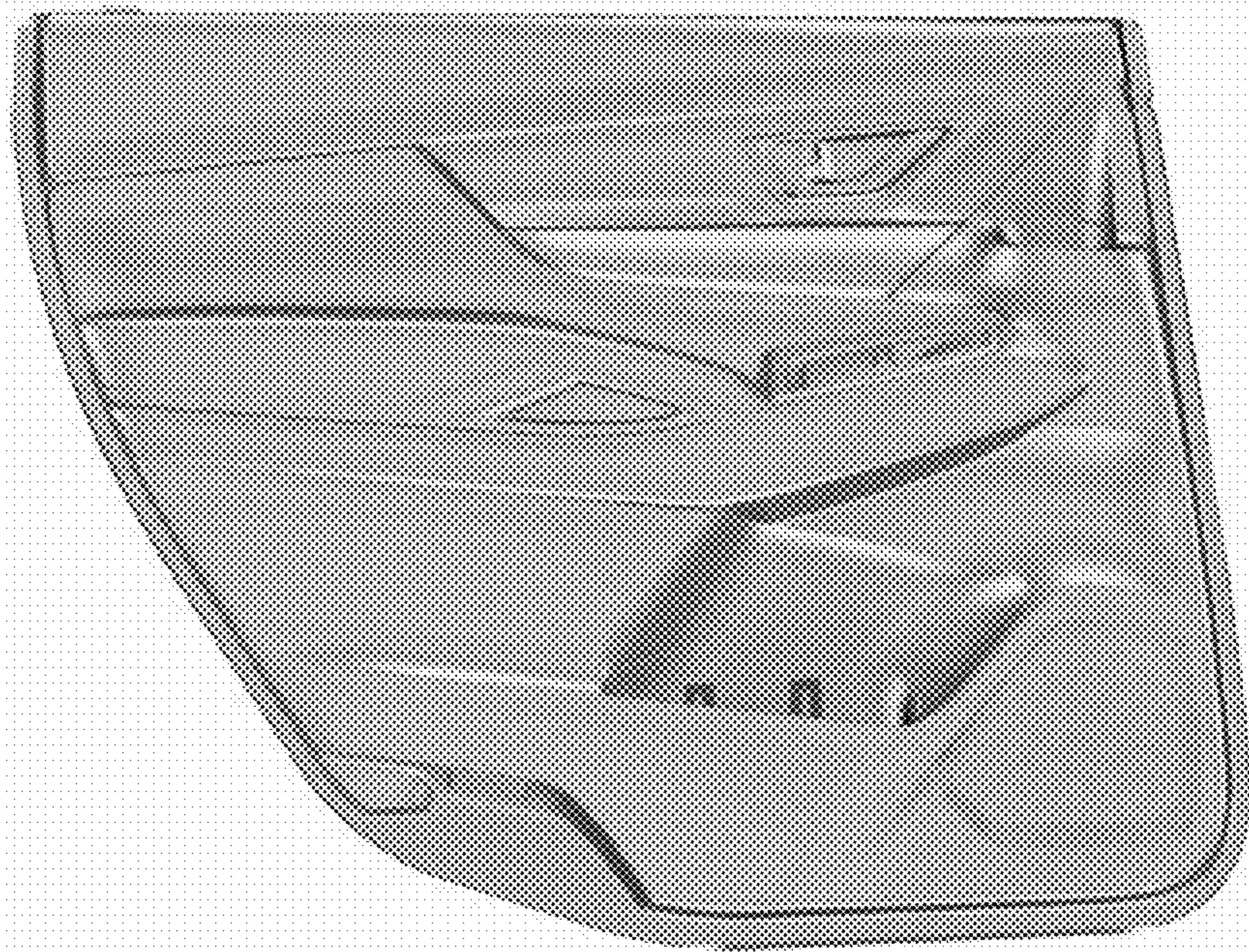

Fig. 4

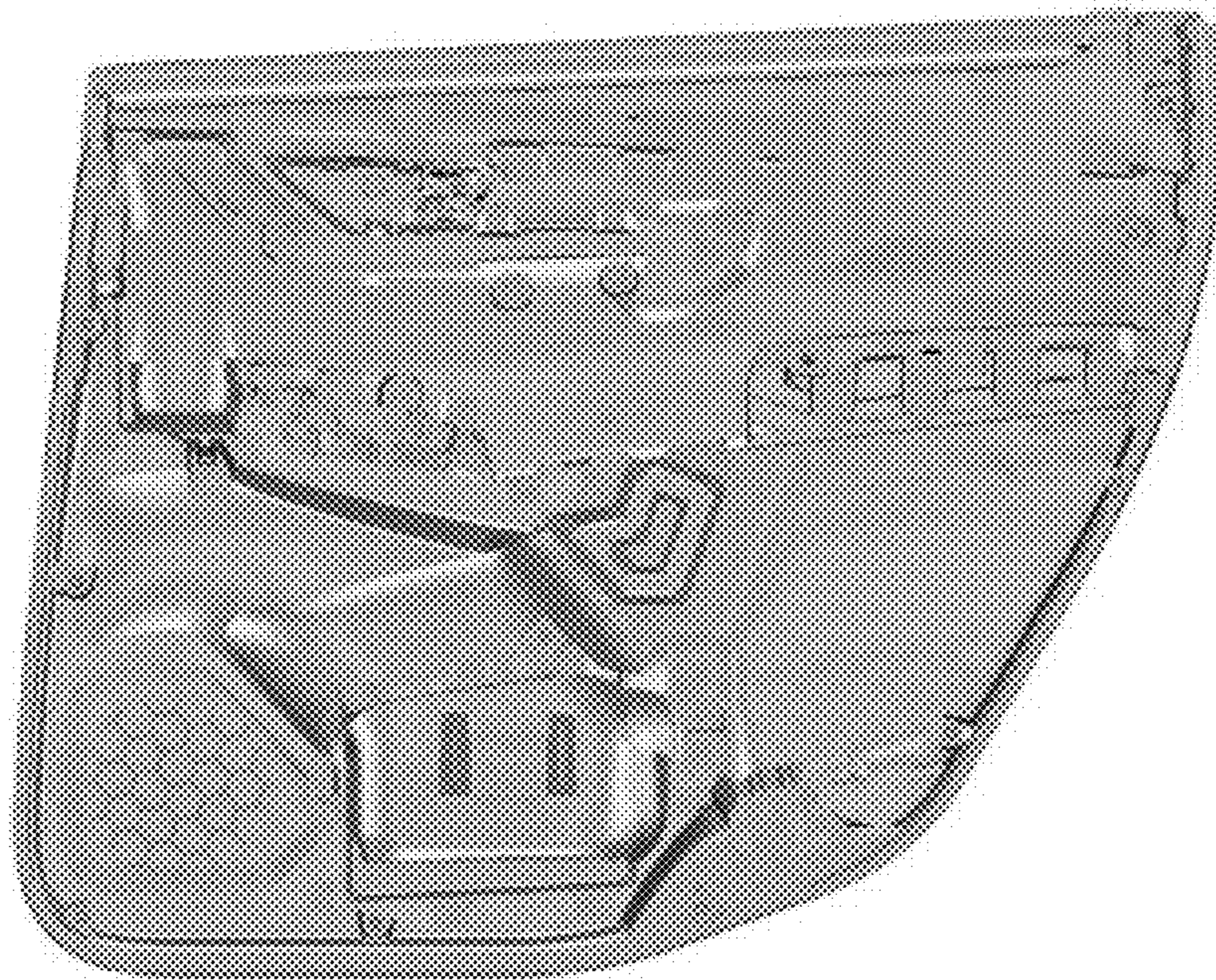

Fig. 5

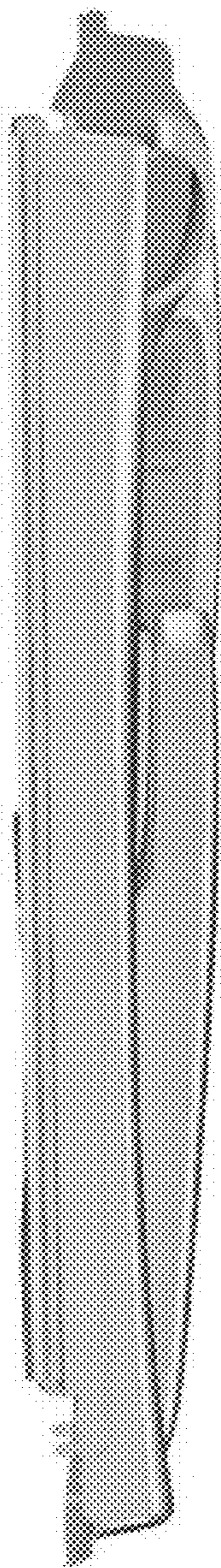

Fig. 6

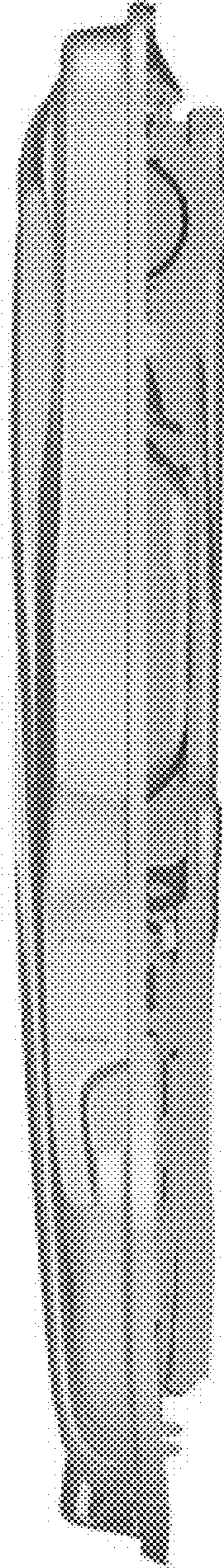

Fig. 7

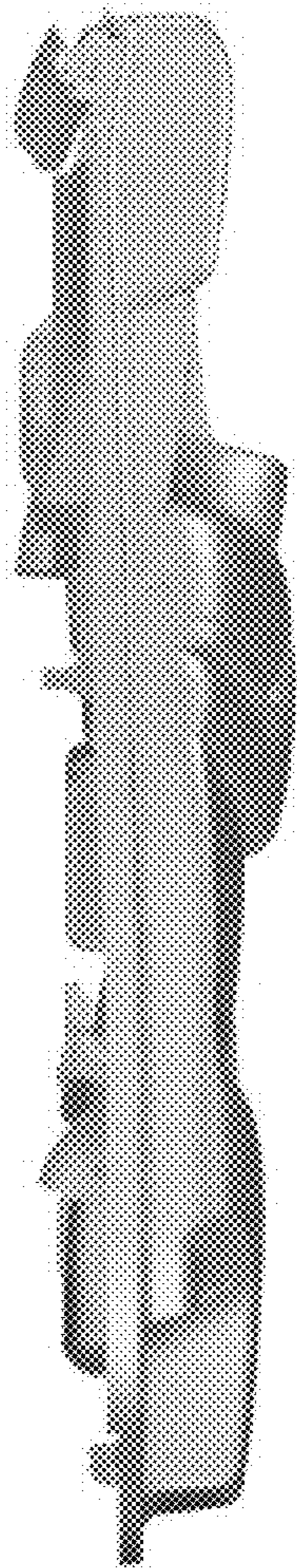

Fig. 8

