



US00D840745S

(12) **United States Design Patent** (10) **Patent No.:** **US D840,745 S**  
**Smith** (45) **Date of Patent:** **\*\* Feb. 19, 2019**

(54) **FOOD PROCESSOR**  
(71) Applicant: **SharkNinja Operating LLC**, Newton, MA (US)  
(72) Inventor: **Cory Smith**, Auburndale, MA (US)  
(73) Assignee: **SHARKNINJA OPERATING LLC**, Needham, MA (US)  
(\*\*) Term: **15 Years**  
(21) Appl. No.: **29/611,681**  
(22) Filed: **Jul. 24, 2017**  
(51) **LOC (11) Cl.** ..... **31-00**  
(52) **U.S. Cl.**  
USPC ..... **D7/384; D7/376; D7/378; D7/412; D7/413**  
(58) **Field of Classification Search**  
USPC ..... **D7/372, 376-386, 412-413, 602, 629, D7/665-666, 669, 679, 693-694**  
(Continued)

(56) **References Cited**  
**U.S. PATENT DOCUMENTS**  
D191,152 S 8/1961 Rawson  
D242,208 S 11/1976 Madl et al.  
(Continued)

**FOREIGN PATENT DOCUMENTS**  
EM 0013887970002 8/2013  
JP S6339330 B2 8/1988  
(Continued)

**OTHER PUBLICATIONS**  
Notice of Allowance; U.S. Appl. No. 29/600,126, filed Apr. 10, 2017; Blender; dated Nov. 15, 2017; 21 Pages.  
(Continued)

*Primary Examiner* — Ricky Pham  
(74) *Attorney, Agent, or Firm* — Cantor Colburn LLP

(57) **CLAIM**  
The ornamental design for an food processor, as shown and described.

**DESCRIPTION**

FIG. 1 is a perspective view of a food processor, showing our new design in a first embodiment;  
FIG. 2 is a front view of the embodiment shown in FIG. 1;  
FIG. 3 is a rear view of the embodiment shown in FIG. 1;  
FIG. 4 is a side view of the embodiment shown in FIG. 1;  
FIG. 5 is another side view of the embodiment shown in FIG. 1;  
FIG. 6 is a top view of the embodiment shown in FIG. 1;  
FIG. 7 is a bottom view of the embodiment shown in FIG. 1;  
FIG. 8 is a perspective view of a food processor, showing our new design another embodiment;  
FIG. 9 is a front view of the embodiment shown in FIG. 8;  
FIG. 10 is a rear view of the embodiment shown in FIG. 8;  
FIG. 11 is a side view of the embodiment shown in FIG. 8;  
FIG. 12 is another side view of the embodiment shown in FIG. 8;  
FIG. 13 is a top view of the embodiment shown in FIG. 8; and,  
FIG. 14 is a bottom view of the embodiment shown in FIG. 8.  
The broken lines in the figures are for environmental purposes only and form no part of the claimed design.  
The oblique line shading represents transparent, translucent or reflective surfaces.

**1 Claim, 12 Drawing Sheets**

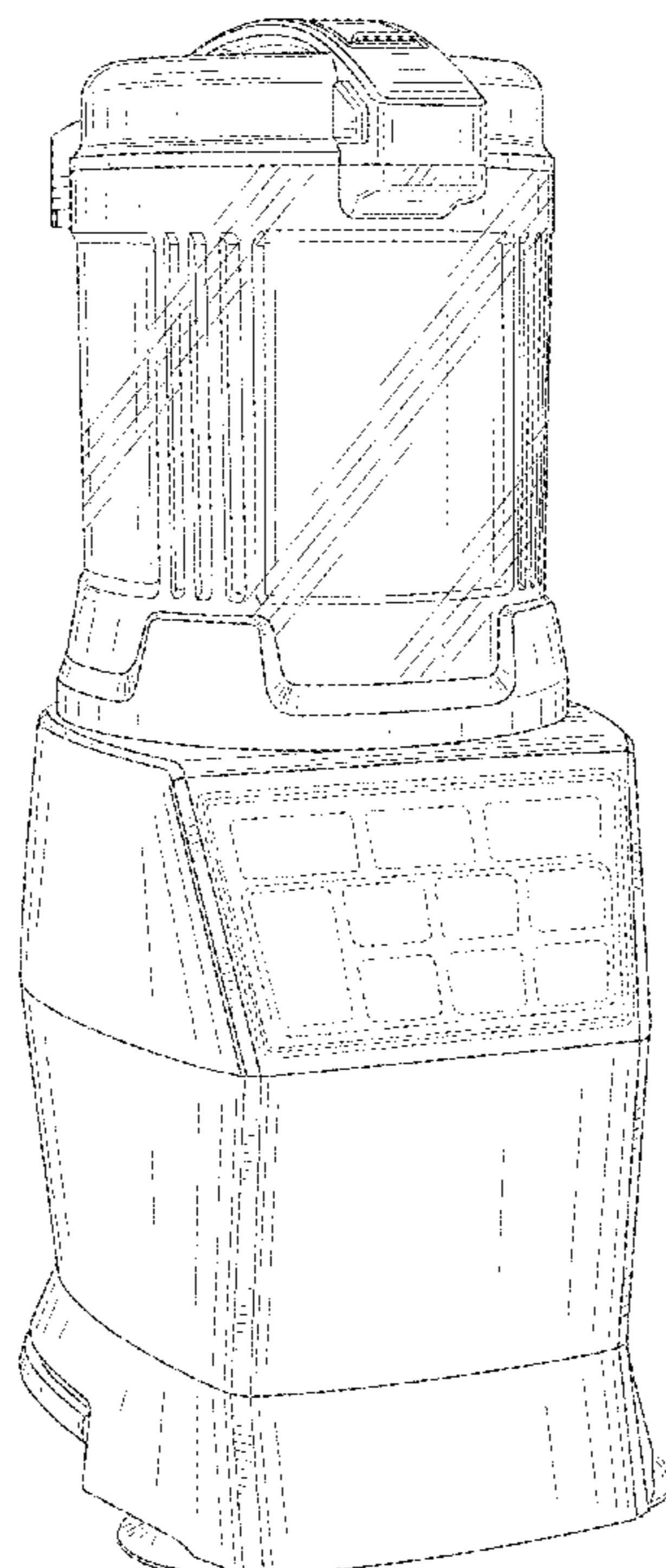

(58) **Field of Classification Search**

CPC .... A21C 1/02; A21C 1/04; A23N 1/00; A23N 1/02; A47J 43/04; A47J 43/25; A47J 43/27; A47J 43/042; A47J 43/044; A47J 43/046; A47J 43/075; A47J 43/0722; A47J 43/0727; B01F 3/00; B01F 3/0807; B01F 3/0853; B01F 13/0059; B01F 13/0064; B02C 1/08; B02C 2/04; B02C 4/42; B02C 4/142; B02C 4/143; B02C 4/423; B02C 13/1835; B28C 5/10; B28C 5/12; B28C 5/14; B28C 5/16

See application file for complete search history.

D708,007	S	7/2014	Lazzer	
D711,688	S	8/2014	Prats	
D730,681	S	6/2015	Smith et al.	
D730,682	S	6/2015	Tu	
D730,683	S	6/2015	Tu	
D731,850	S	6/2015	Smith	
D733,488	S	7/2015	Tu	
D745,316	S	12/2015	Usmar	
D745,317	S	12/2015	Dichraff et al.	
9,265,381	B2	2/2016	Beber et al.	
D755,003	S	5/2016	Palermo et al.	
D758,126	S	6/2016	Benoit et al.	
D761,617	S	7/2016	Dennisur et al.	
D765,462	S	9/2016	Davies	
D765,465	S	9/2016	Du	
D766,649	S	9/2016	Suzuki	
9,439,538	B2	9/2016	Paget	
D771,999	S	11/2016	Kettavong et al.	
D772,011	S	11/2016	Barquin et al.	
D772,650	S	11/2016	Barquin et al.	
D773,247	S	12/2016	Barquin et al.	
D773,248	S	12/2016	Barquin et al.	
D773,249	S	12/2016	Barquin et al.	
D778,665	S	2/2017	Barquin et al.	
D779,265	S	2/2017	Barquin et al.	
D780,507	S	3/2017	Barquin et al.	
D783,340	S	4/2017	Palermo et al.	
D783,355	S	4/2017	Tu	
D786,613	S	5/2017	McConnell et al.	
D786,614	S	5/2017	Smith et al.	
D786,615	S	5/2017	Tsai	
D787,882	S	5/2017	McConnell et al.	
D787,883	S *	5/2017	Tu .....	D7/376
D788,520	S	6/2017	Blaise	
D789,735	S	6/2017	Palermo et al.	
D789,736	S	6/2017	Palermo et al.	
9,675,212	B2 *	6/2017	Hewitt .....	A47J 43/0727
D793,153	S	8/2017	Tu	
D794,384	S	8/2017	Lee	
D795,005	S	8/2017	Coakley et al.	
D797,496	S	9/2017	Gee, II et al.	
D797,505	S	9/2017	Tu	
D807,118	S	1/2018	Kettavong et al.	
D808,718	S *	1/2018	Coakley .....	D7/413
D808,719	S *	1/2018	Coakley .....	D7/413
9,855,535	B2	1/2018	Arnett, et al.	
D809,333	S *	2/2018	Lee .....	D7/386
D809,334	S *	2/2018	Lee .....	D7/386
D809,342	S *	2/2018	Coakley .....	D7/413
D811,804	S *	3/2018	Smith .....	D7/384
D811,805	S *	3/2018	Smith .....	D7/384
D811,806	S *	3/2018	Bock .....	D7/386
D812,963	S *	3/2018	Smith .....	D7/384
D812,964	S *	3/2018	Tu .....	A47J 43/0727
				D7/386
D813,603	S *	3/2018	Tu .....	D7/413
D821,806	S	7/2018	Coakley et al.	
D823,637	S	7/2018	Coakley	
2008/0089170	A1	4/2008	Larsen et al.	
2008/0089171	A1	4/2008	Larsen et al.	
2008/0219089	A1	9/2008	Sandford et al.	
2009/0129200	A1	5/2009	Breviere et al.	
2010/0246319	A1	9/2010	Pryor, Jr. et al.	
2014/0247686	A1	9/2014	Arnett et al.	
2016/0220071	A1	8/2016	Hewitt et al.	
2016/0331182	A1	11/2016	Golino	

(56) **References Cited**

U.S. PATENT DOCUMENTS

D256,318	S	8/1980	Levin
D293,195	S	12/1987	Kim
D302,228	S	7/1989	Barrault
D338,803	S	8/1993	Littmann
D367,583	S	3/1996	Littmann
D373,703	S	9/1996	Frisell
D404,606	S	1/1999	Huang
D404,607	S	1/1999	Huang
D444,026	S	6/2001	Chaudeurge
D445,637	S	7/2001	Feil
D450,978	S	11/2001	Smith
D453,662	S	2/2002	Hensel
D488,344	S	4/2004	Seum et al.
D502,047	S	2/2005	Ledingham et al.
D512,265	S	12/2005	McCurrach
D526,531	S	8/2006	Drees et al.
D533,395	S	12/2006	Drees et al.
D551,915	S	10/2007	Chang Chien
D552,412	S	10/2007	Steiner
D552,419	S	10/2007	Picozza et al.
D553,904	S	10/2007	Romandy
D567,578	S	4/2008	Chiappetta
D568,096	S	5/2008	Sun
D577,537	S	9/2008	Lee
D587,961	S	3/2009	Lavy
7,581,668	B2	9/2009	Mally
D605,462	S	12/2009	Picozza et al.
D611,760	S	3/2010	Ball
D617,136	S	6/2010	Bock et al.
D617,145	S	6/2010	Picozza et al.
D625,141	S	10/2010	Moore
D637,870	S	5/2011	Bock
D642,857	S	8/2011	Bodum
D644,480	S	9/2011	Czach et al.
D645,301	S	9/2011	Tse
D647,357	S	10/2011	Audette et al.
D647,367	S	10/2011	Audette et al.
D647,368	S	10/2011	Audette et al.
D650,229	S	12/2011	Hensel et al.
D654,305	S	2/2012	Gursel et al.
D655,981	S	3/2012	Gursel et al.
D658,430	S	5/2012	Hoare et al.
D660,642	S	5/2012	Boozer et al.
D667,259	S	9/2012	Lee et al.
D667,260	S	9/2012	Lee et al.
D667,261	S	9/2012	Lee et al.
D668,100	S	10/2012	Palermo et al.
D674,235	S	1/2013	Lee et al.
D674,658	S	1/2013	Fouquet
D677,976	S	3/2013	Palermo et al.
D690,152	S	9/2013	Palermo et al.
D694,573	S	12/2013	Norland et al.
D694,574	S	12/2013	Norland et al.
D694,582	S	12/2013	Norland
D694,583	S	12/2013	Norland
D695,060	S	12/2013	Penaherrera et al.
D696,063	S	12/2013	Coakley et al.
D702,078	S	4/2014	Coakley et al.
D704,502	S	5/2014	Coakley et al.

FOREIGN PATENT DOCUMENTS

JP	D1491536	S	3/2014
JP	D1488258	S	1/2015
JP	D1533047	S	9/2015
JP	D1545614	S	3/2016
JP	D1592330	S	12/2017
JP	D1592331	S	12/2017
JP	D1603847	S	5/2018
JP	D1603848	S	5/2018

(56)

**References Cited**

## FOREIGN PATENT DOCUMENTS

KR	300382339 S	5/2005
KR	300398683 S	11/2005

## OTHER PUBLICATIONS

Notice of Decision for Design Registration; Korean Application No. 30-2017-0009484; dated Nov. 5, 2016; 6 Pages.

Notice of Decision for Design Registration; Korean Application No. 30-2017-0009485; dated Nov. 5, 2017; 6 Pages.

Notice of Allowance; U.S. Appl. No. 29/576,021, filed Aug. 31, 2016; Food Processor and Parts Thereof; dated Nov. 15, 2017; 34 pages.

Formalities Notice No. 1—Requirements for Registration Not Met; Australian Design Application No. 201810355; dated Feb. 15, 2018; 3 Pages.

Formalities Notice No. 1—Requirements for Registration Not Met; Australian Design Application No. 201810356; dated Feb. 15, 2018; 3 Pages.

Formalities Notice No. 1—Requirements for Registration Not Met; Australian Design Application No. 201810357; dated Feb. 15, 2018; 3 Pages.

Japanese Design No. D1592330 (S); Publication Date: Dec. 4, 2017; Machine Translation; 14 Pages.

Japanese Design No. D1592331 (S); Publication Date: Dec. 4, 2017; Machine Translation; 14 Pages.

Notice of Allowance; Japanese Application No. 2017-018724; dated Mar. 9, 2018; 4 Pages.

Notice of Allowance; Japanese Application No. 2017-018725; dated Mar. 9, 2018; 4 Pages.

Notice of Allowance; Japanese Application No. 2017-019764; dated Mar. 9, 2018; 4 Pages.

Notice of Allowance; Japanese Application No. 2017-019765; dated Mar. 9, 2018; 4 Pages.

WMF Württembergische Metallwarenfabrik; 61 3024 5401; JPO Publicly Known Design No. HJ26034868; Listed in Notice of Allowance Received in JP Appln. No. 2017-019764, dated Mar. 9, 2018; 3 Pages.

Application for Registration of an Industrial Design Examiner's Report; Canadian Application No. 176806; dated Oct. 30, 2017; 2 Pages.

Application for Registration of an Industrial Design Examiner's Report; Canadian Application No. 176809; dated Oct. 30, 2017; 2 Pages.

Examination Report; Community Design(s) Registration Nos. 004676815-0001 through 004676815-0008; dated Jan. 29, 2018; 2 Pages.

Examination Report; Community Design(s) Registration Nos. 004676864-0001 through 004676864-0008; dated Jan. 29, 2018; 2 Pages.

Notice of Completion of Formalities for Patent Register and Notice of Grant of Design Patent Right; Chinese Application No. 2017300521056; dated Aug. 29, 2017; 5 Pages.

Notice of Decision for Design Registration; Korean Design Application No. 30-2017-0009475; dated Aug. 18, 2017; 6 Pages.

Notice of Decision for Design Registration; Korean Design Application No. 30-2017-0009476; dated Sep. 11, 2017; 6 Pages.

Notice of Decision for Design Registration; Korean Design Application No. 30-2017-0009477; dated Aug. 18, 2017; 6 Pages.

Notice of Decision for Design Registration; Korean Design Application No. 30-2017-0009479; dated Aug. 22, 2017; 6 Pages.

Notice of Decision for Design Registration; Korean Design Application No. 30-2017-0009482; dated Aug. 22, 2017; 6 Pages.

Notice of Decision for Design Registration; Korean Design Application No. 30-2017-0009483; dated Aug. 18, 2017; 6 Pages.

Notice of Decision for Design Registration; Korean Design Application No. 30-2017-0009486; dated Aug. 22, 2017; 6 Pages.

Notice of Decision for Design Registration; Korean Design Application No. 30-2017-0009488; dated Aug. 22, 2017; 6 Pages.

Notice of Preliminary Rejection; Korean Application No. 30-2017-0009484; dated Aug. 18, 2017; 7 Pages.

Notice of Preliminary Rejection; Korean Application No. 30-2017-0009485; dated Aug. 18, 2017; 6 Pages.

Application for Registration of an Industrial Design Examiner's Report; Canadian Application No. 172856; dated Sep. 20, 2017; 2 Pages.

Application for Registration of an Industrial Design Examiner's Report; Canadian Application No. 172857; dated Sep. 20, 2017; 2 Pages.

Japanese Design No. D1545614 (S); Publication Date: Mar. 14, 2016; Machine Translation; 6 Pages.

Notice of Allowance; Japanese Application No. 2017-003904; dated Oct. 6, 2017; 4 Pages.

Notice of Allowance; Japanese Application No. 2017-003905; dated Oct. 6, 2017; 4 Pages.

Notice of Allowance; U.S. Appl. No. 29/576,018, filed Aug. 31, 2016; Food Processor and Parts Thereof; dated Oct. 25, 2017; 27 Pages.

Notice of Allowance; U.S. Appl. No. 29/576,020, filed Aug. 31, 2016; Food Processor and Parts Thereof; dated Oct. 16, 2017; 32 Pages.

Requirement for Restriction/Election; Blender; U.S. Appl. No. 29/600,129, filed Apr. 10, 2017; dated Oct. 10, 2017; 30 Pages.

Requirement for Restriction/Election; Blender; U.S. Appl. No. 29/604,189, filed May 16, 2017; dated Oct. 10, 2017; 33 Pages.

Application for Registration of an Industrial Design Examiner's Report; Canadian Application No. 172856; dated May 31, 2017; 3 Pages.

Application for Registration of an Industrial Design Examiner's Report; Canadian Application No. 172857; dated May 31, 2017; 3 Pages.

Design No. 28449; Soviet Design Gazette; vol. 3; Published: Sep. 15, 1990; pp. 180-181.

Japanese Design No. D1491535 (S); Publication Date: Mar. 3, 2014; Machine Translation; 9 Pages.

Japanese Design No. D1491536 (S); Publication Date: Mar. 3, 2014; Machine Translation; 9 Pages.

Japanese Design No. D1518840 (S); Publication Date: Mar. 9, 2014; Machine Translation; 10 Pages.

Japanese Design No. D1523840 (S); Publication Date: May 18, 2015; Machine Translation; 9 Pages.

Japanese Design No. D1528172 (S); Publication Date: Jul. 6, 2015; Machine Translation; 9 Pages.

Japanese Design No. D1533047 (S); Publication Date: Sep. 7, 2015; Machine Translation; 9 Pages.

Notice of Allowance; Blender Base; U.S. Appl. No. 29/531,840, filed Jun. 30, 2015; dated Oct. 4, 2016; 7 Pages.

Notice of Allowance; Blender Base; U.S. Appl. No. 29/531,840, filed Jun. 30, 2015; dated Nov. 25, 2016; 11 Pages.

Notice of Allowance; Blender Base; U.S. Appl. No. 29/531,840, filed Jun. 30, 2015; dated Feb. 16, 2017; 11 Pages.

Notice of Allowance; Blender; U.S. Appl. No. 29/519,682, filed Mar. 6, 2015; dated Aug. 12, 2016; 6 Pages.

Notice of Allowance; Blender; U.S. Appl. No. 29/519,682, filed Mar. 6, 2015; dated Sep. 23, 2016; 12 Pages.

Notice of Allowance; Blender; U.S. Appl. No. 29/527,670, filed May 21, 2015; dated Aug. 9, 2016; 7 Pages.

Notice of Allowance; Blender; U.S. Appl. No. 29/527,670, filed May 21, 2015; dated Sep. 27, 2016; 12 Pages.

Notice of Allowance; U.S. Appl. No. 29/519,682, filed Sep. 6, 2015; Blender; dated Jan. 9, 2017; 11 Pages.

Notice of Allowance; U.S. Appl. No. 29/527,670, filed May 21, 2015; Blender; dated Jan. 9, 2017; 11 Pages.

Notice of Completion of Formalities for Patent Register and Notice of Grant of Design Patent Right; Chinese Application No. 2017300502943; dated Jun. 19, 2017; 5 Pages.

Notice of Completion of Formalities for Patent Register and Notice of Grant of Design Patent Right; Chinese Application No. 2017300505640; dated Jul. 11, 2017; 5 Pages.

Notice of Completion of Formalities for Patent Register and Notice of Grant of Design Patent Right; Chinese Application No. 201730050566X; dated Jul. 10, 2017; 5 Pages.

(56)

**References Cited**

## OTHER PUBLICATIONS

Notice of Completion of Formalities for Patent Register and Notice of Grant of Design Patent Right; Chinese Application No. 201730052179X; dated Aug. 2, 2017; 5 Pages.

Notice of Completion of Formalities for Patent Register and Notice of Grant of Design Patent Right; Chinese Application No. 2017300523386; dated Jun. 6, 2017; 5 Pages.

Notice of Completion of Formalities for Patent Register and Notice of Grant of Design Patent Right; Chinese Application No. 2017300541897; dated Jul. 18, 2017; 5 Pages.

Notice of Completion of Formalities for Patent Register and Notice of Grant of Design Patent Right; Chinese Application No. 2017300544679; dated Jul. 6, 2017; 5 Pages.

Notice of Completion of Formalities for Patent Register and Notice of Grant of Design Patent Right; Chinese Application No. 2017300546640; dated Jun. 21, 2017; 5 Pages.

Notice of References; Japanese Design Application No. 2015-19809; dated Jan. 8, 2016; 2 Pages.

Notice of References; Japanese Design Application No. 2015-19810; dated Jan. 8, 2016; 2 Pages.

Notice of References; Japanese Design Application No. 2015-19811; dated Jan. 8, 2016; 2 Pages.

Notice of References; Japanese Design Application No. 2015-19812; dated Jan. 8, 2016; 2 Pages.

Notice of References; Japanese Design Application No. 2015-19813; dated Jan. 8, 2016; 2 Pages.

Notice of References; Japanese Design Application No. 2015-19814; dated Jan. 8, 2016; 2 Pages.

Notice of References; Japanese Design Application No. 2015-19815; dated Jan. 8, 2016; 2 Pages.

Notice of References; Japanese Design Application No. 2015-19816; dated Jan. 8, 2016; 2 Pages.

Notice of References; Japanese Design Application No. 2015-19817; dated Jan. 8, 2016; 2 Pages.

Notification of Reasons for Rejection; Japanese Design Application No. 2017-003904; dated Jun. 9, 2017; 3 Pages.

Notification of Reasons for Rejection; Japanese Design Application No. 2017-003905; dated Jun. 9, 2017; 3 Pages.

Requirement for Restriction/Election; Blender; U.S. Appl. No. 29/519,682, filed Mar. 6, 2015; 6 Pages.

Requirement for Restriction/Election; Blender; U.S. Appl. No. 29/527,670, filed May 21, 2015; 6 Pages.

Requirement for Restriction/Election; Blender; U.S. Appl. No. 29/531,840, filed Jun. 30, 2015; 7 Pages.

Requirement for Restriction/Election; U.S. Appl. No. 29/576,018, filed Aug. 31, 2016; Food Processor and Parts Thereof; dated Jul. 6, 2017; 7 Pages.

Requirement for Restriction/Election; U.S. Appl. No. 29/576,020, filed Aug. 31, 2016; Food Processor and Parts Thereof; dated Jul. 5, 2017; 7 Pages.

Requirement for Restriction/Election; U.S. Appl. No. 29/576,021, filed Aug. 31, 2016; Food Processor and Parts Thereof; dated Jul. 6, 2017; 7 Pages.

Walmart; "Oster 600-Watt Fusion Blender, BRLY07-B00-000"; URL: <http://www.walmart.com/ip/Oster-600-Watt-Fusion-Blender/9604653>; URL Accessed: Jul. 29, 2016; 8 Pages.

JP Notice of Allowance with English Translation; Japanese Design Application No. 2018-1280; dated Sep. 28, 2018; pp. 1-6.

JP Notice of Allowance with English Translation; Japanese Design Application No. 2018-1282; dated Sep. 28, 2018; pp. 1-6.

JP Notice of Allowance with English Translation; Japanese Design Application No. 2018-1286; dated Sep. 28, 2018; pp. 1-6.

JP Notice of Allowance with English Translation; Japanese Design Application No. 2018-6518; dated Sep. 28, 2018; pp. 1-6.

Requirement for Restriction/Election; Blender Base; U.S. Appl. No. 29/653,896; filed Jun. 19, 2018; 1-31 Pages; Available in Image File Wrapper.

Requirement for Restriction/Election; Food Processor and Parts Thereof; U.S. Appl. No. 29/611,684; filed Jul. 24, 2017; 1-50 Pages; Available in Image File Wrapper.

Requirement for Restriction/Election; Food Processor and Parts Thereof; U.S. Appl. No. 29/611,685; filed Jul. 24, 2017; 1-50 Pages; Available in Image File Wrapper.

Requirement for Restriction/Election; Food Processor and Parts Thereof; U.S. Appl. No. 29/633,798; filed Jan. 16, 2017; 1-20 Pages; Available in Image File Wrapper.

Requirement for Restriction/Election; Food Processor and Parts Thereof; U.S. Appl. No. 29/634,264; filed Jan. 19, 2018; 1-20 Pages; Available in Image File Wrapper.

Requirement for Restriction/Election; Food Processor and Parts Thereof; U.S. Appl. No. 29/637,154; filed Feb. 14, 2018; 1-21 Pages; Available in Image File Wrapper.

\* cited by examiner

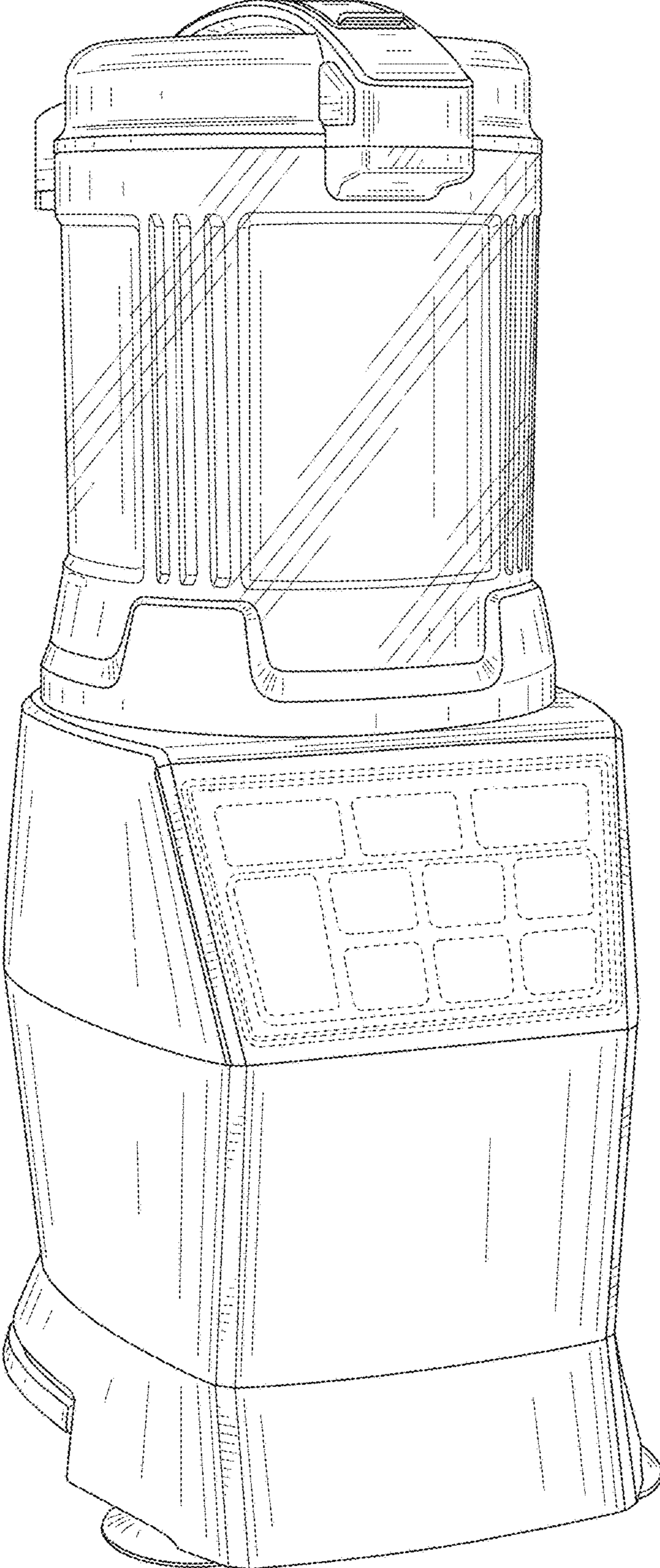

FIG. 1

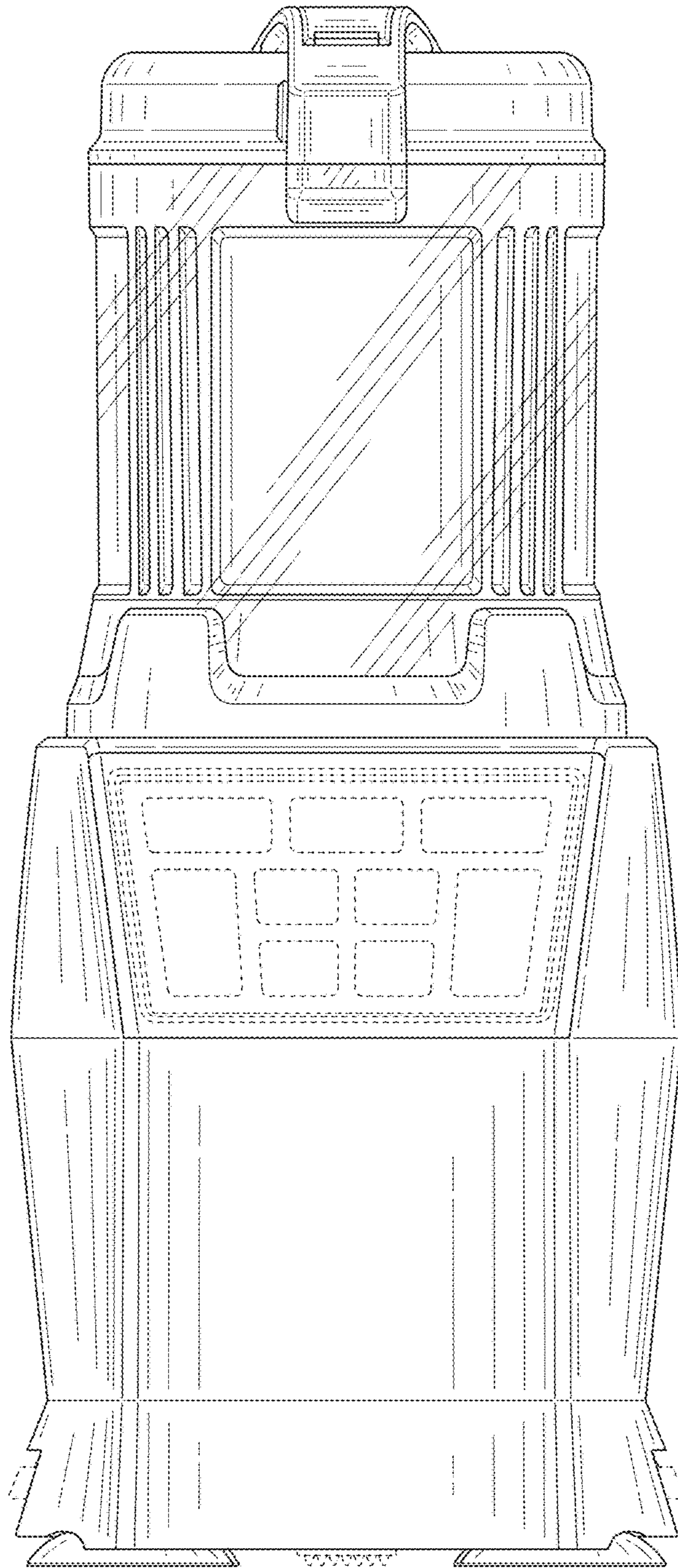

FIG. 2

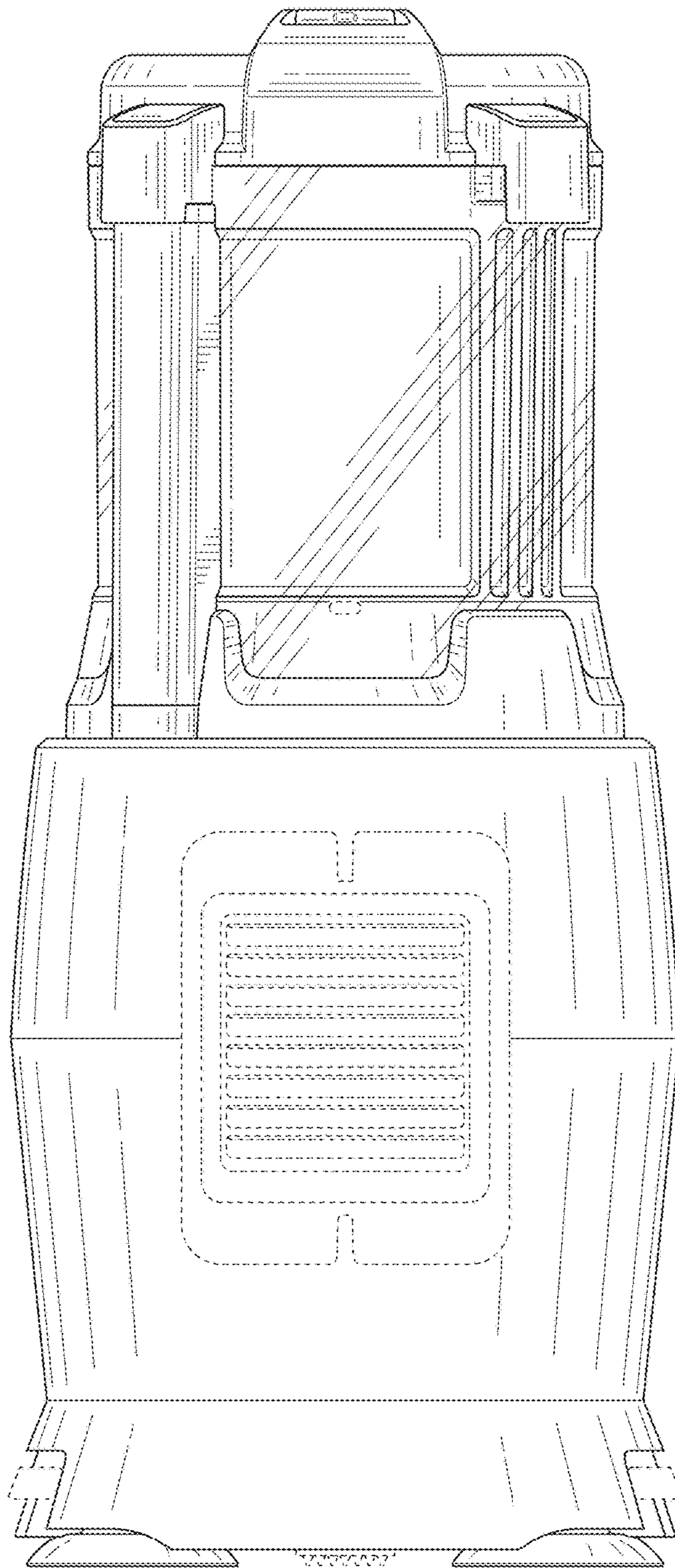

FIG. 3

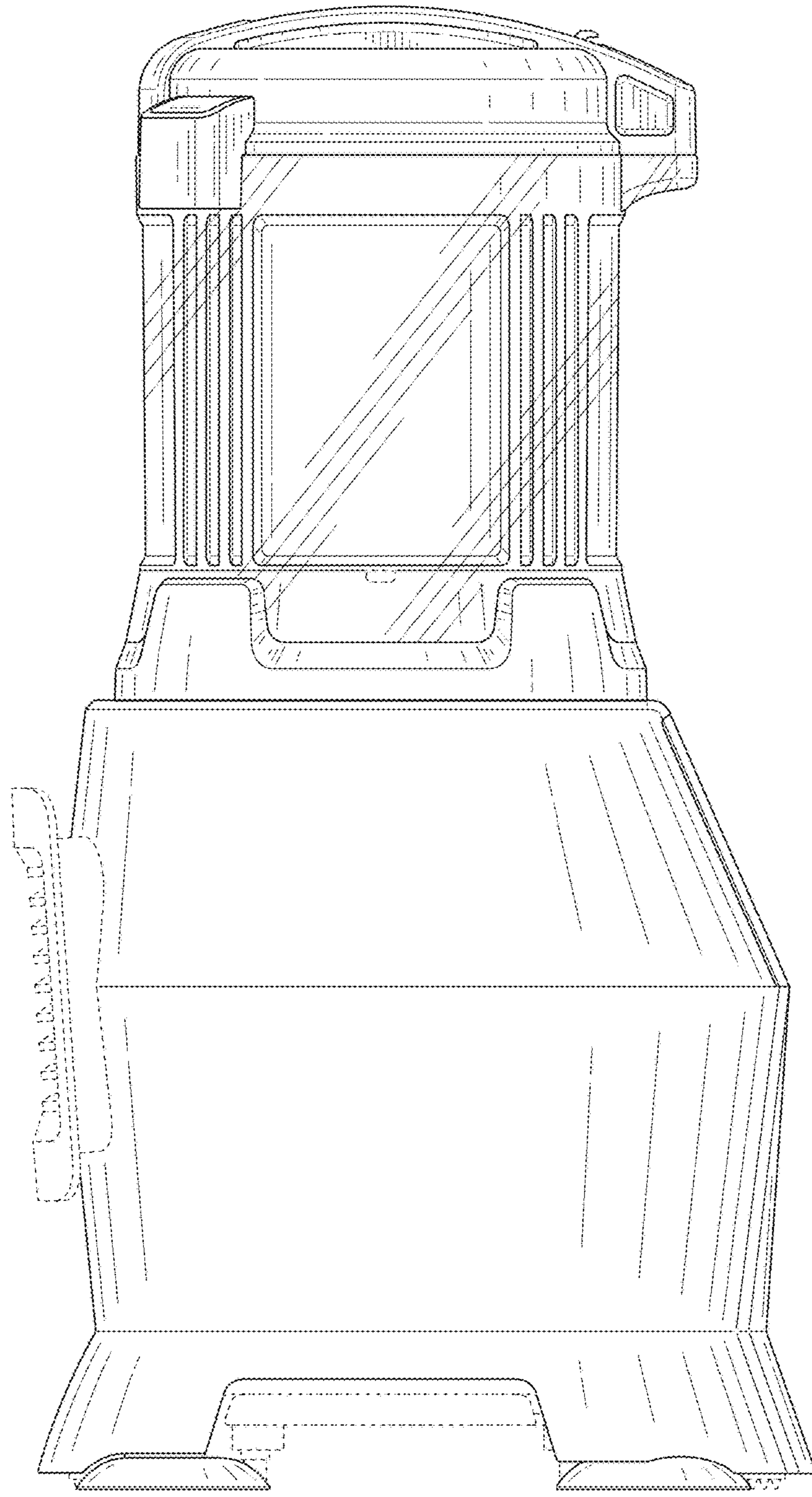

FIG. 4



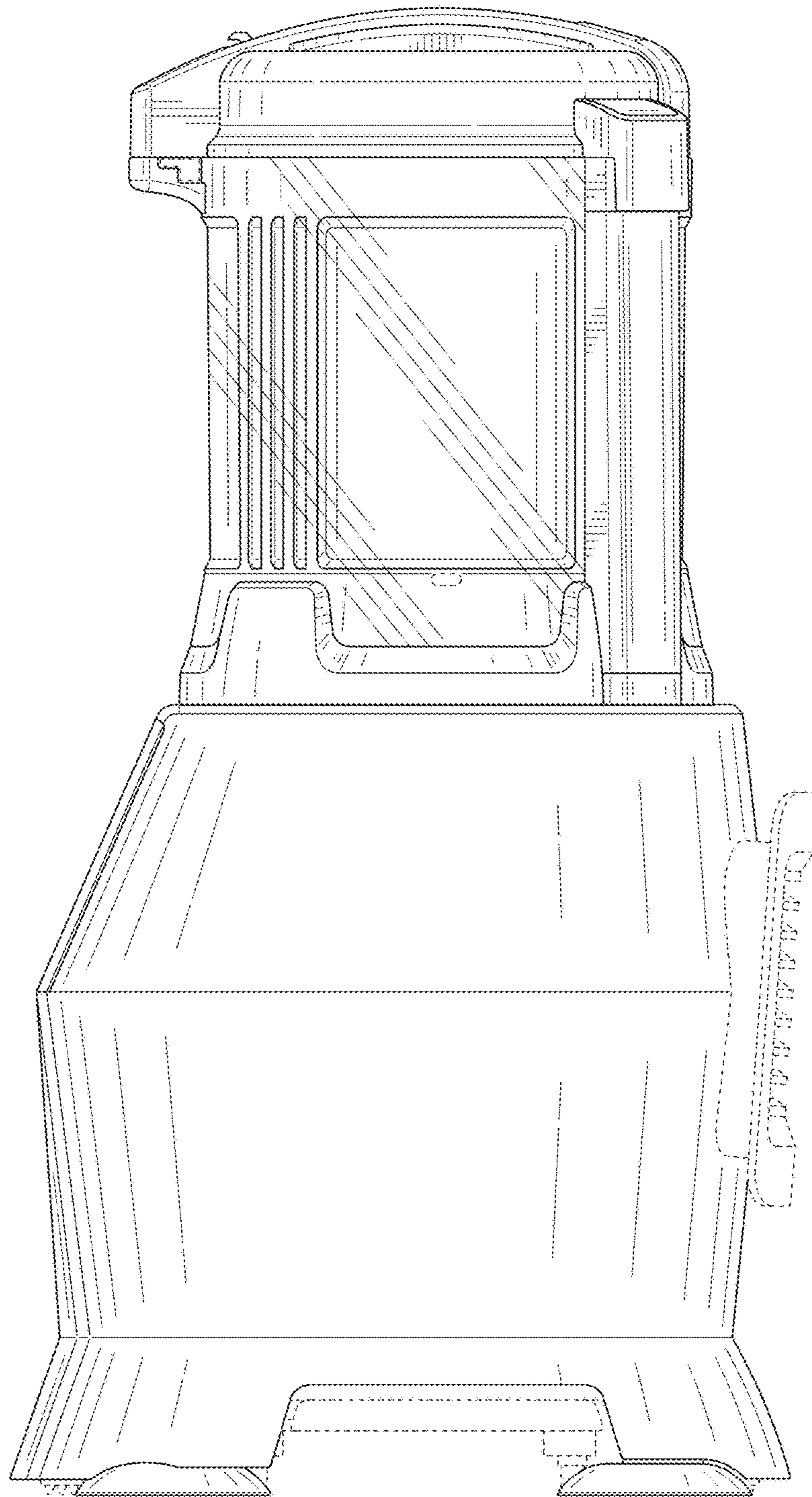

FIG. 5

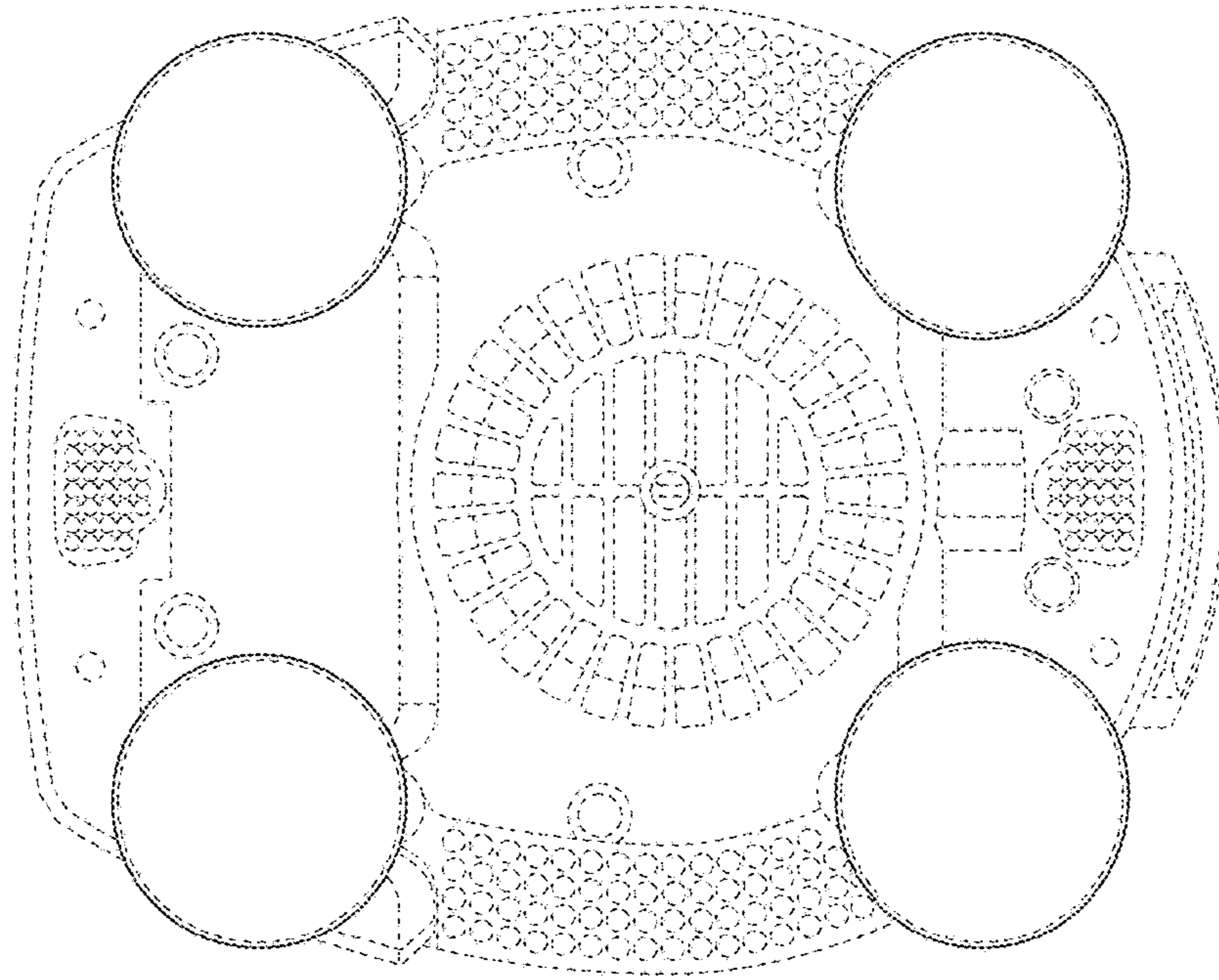

FIG. 6

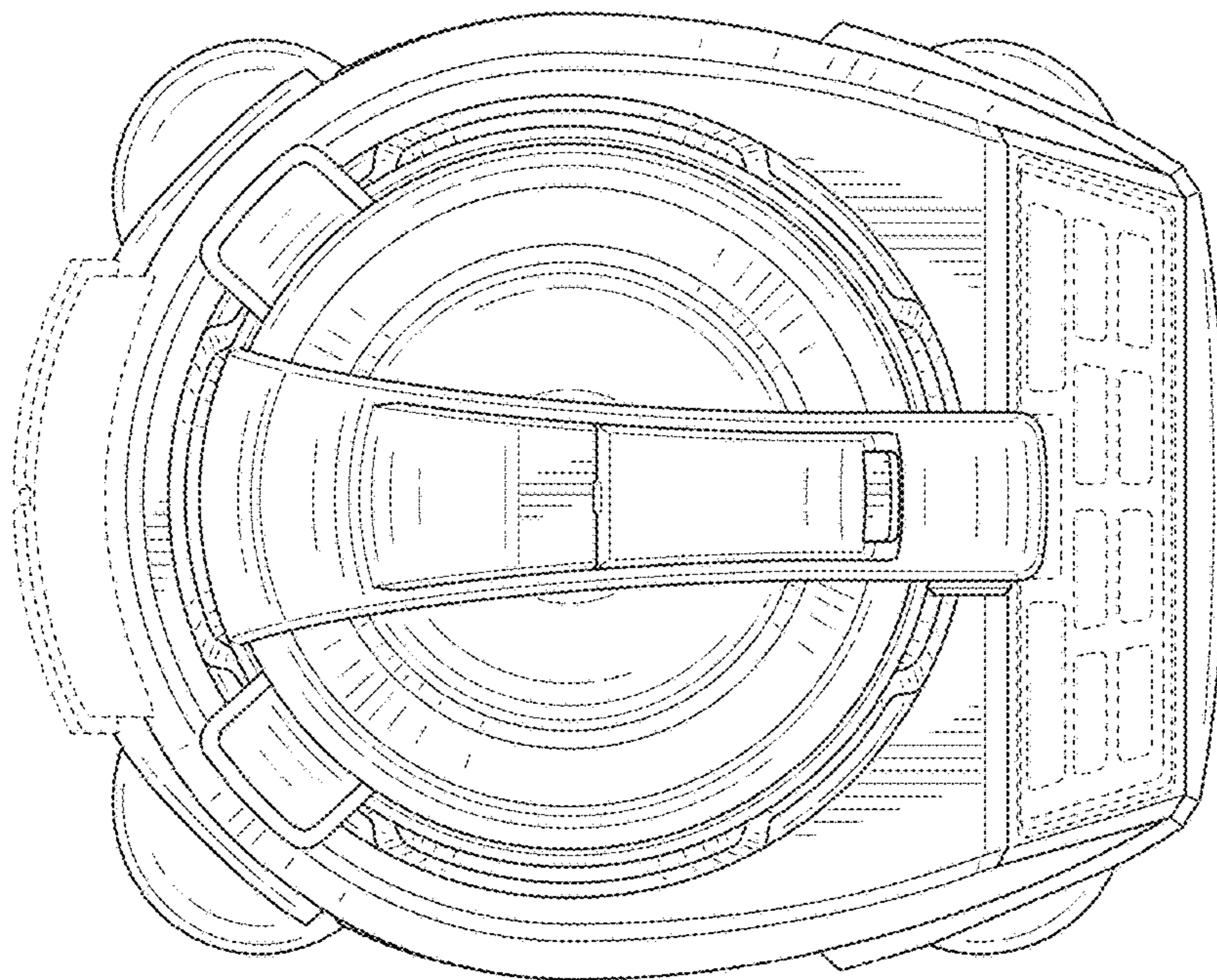

FIG. 7

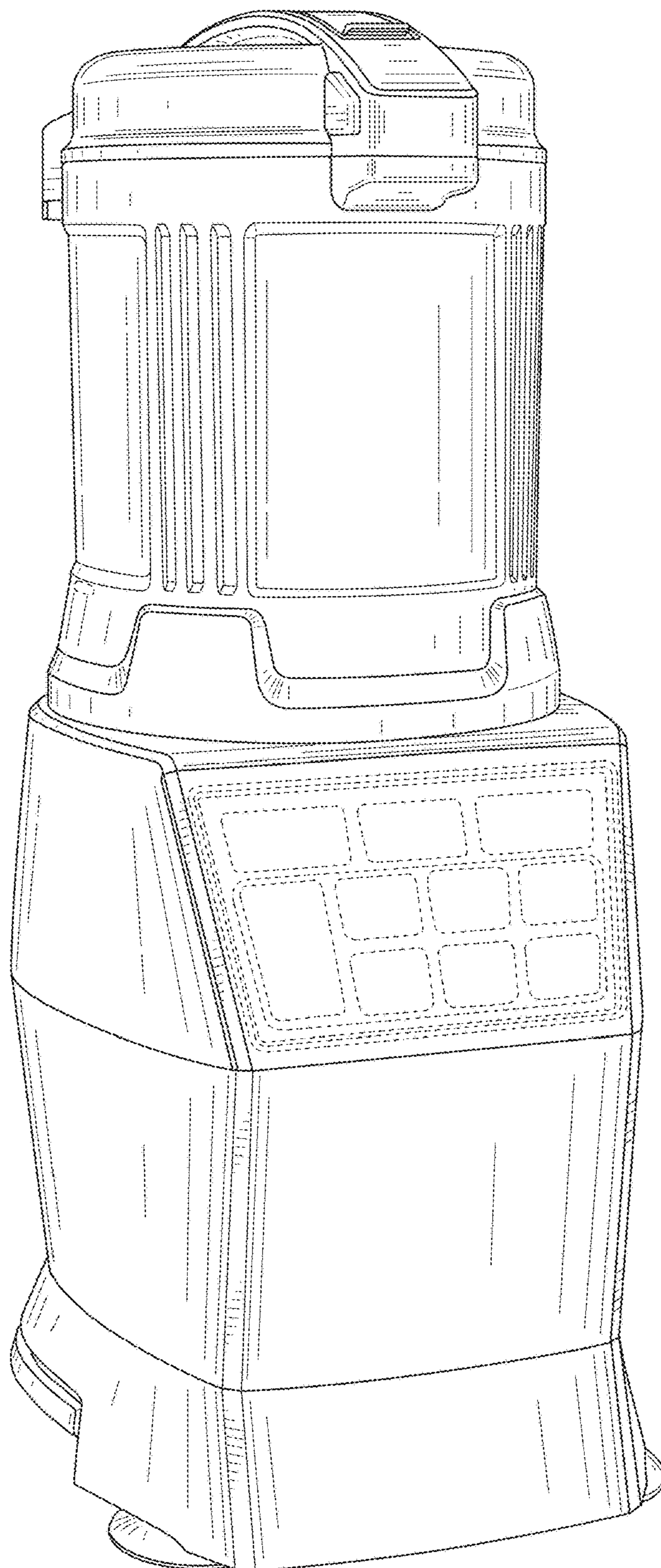

FIG. 8

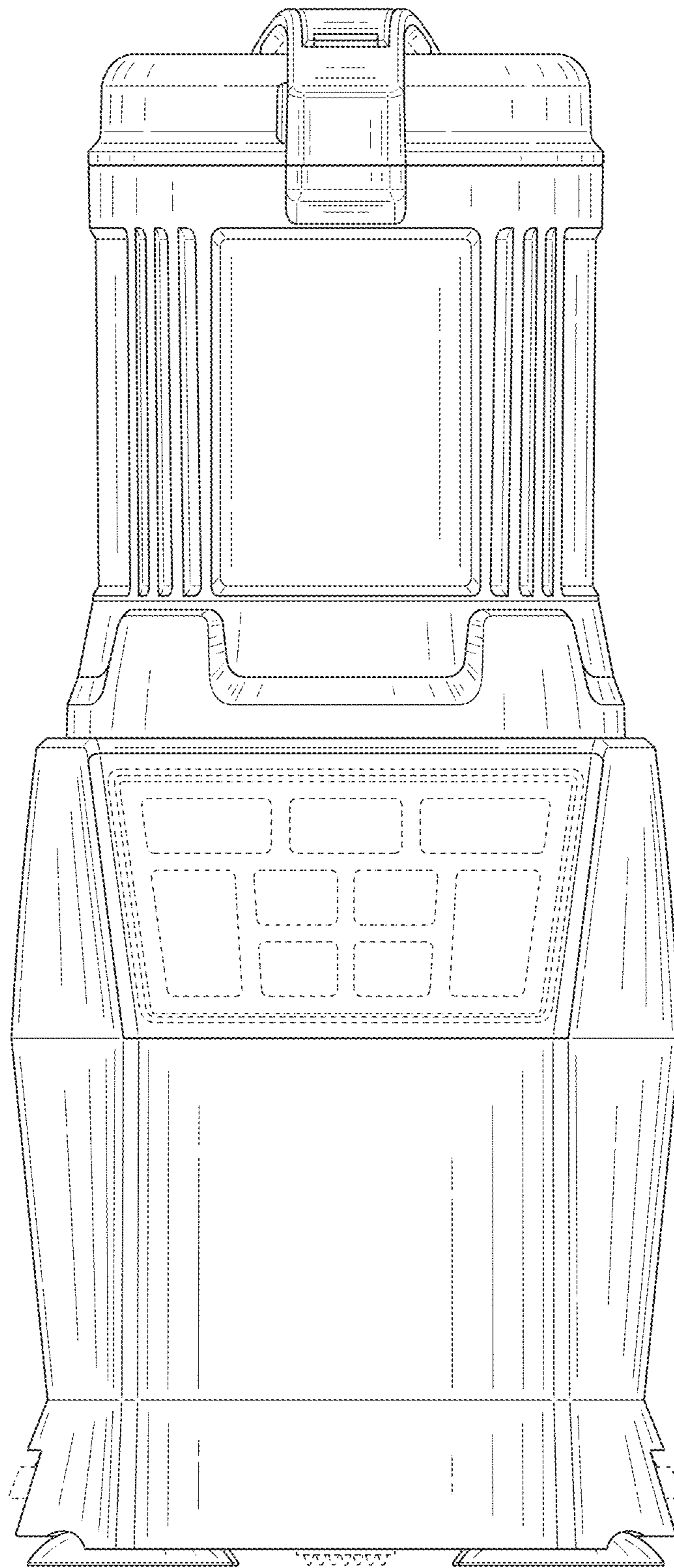

FIG. 9

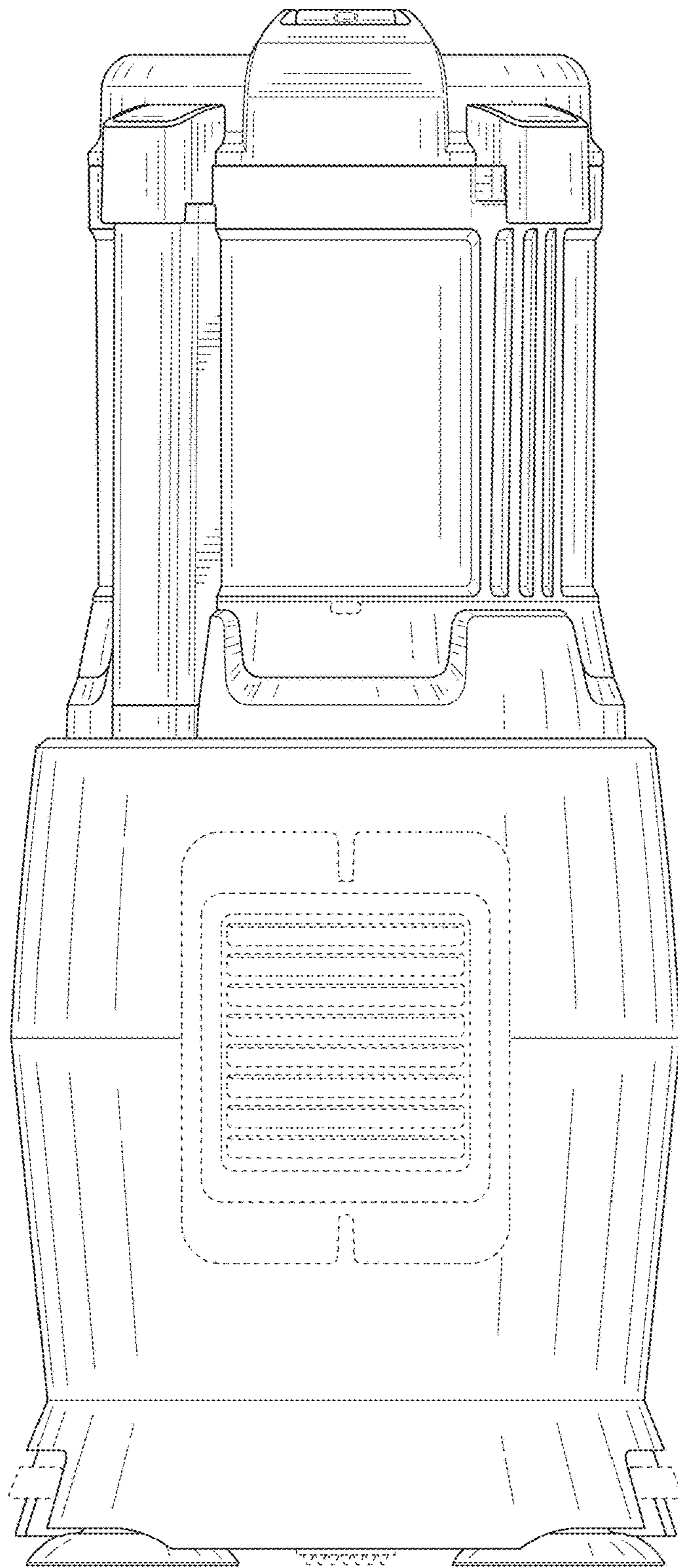

FIG. 10

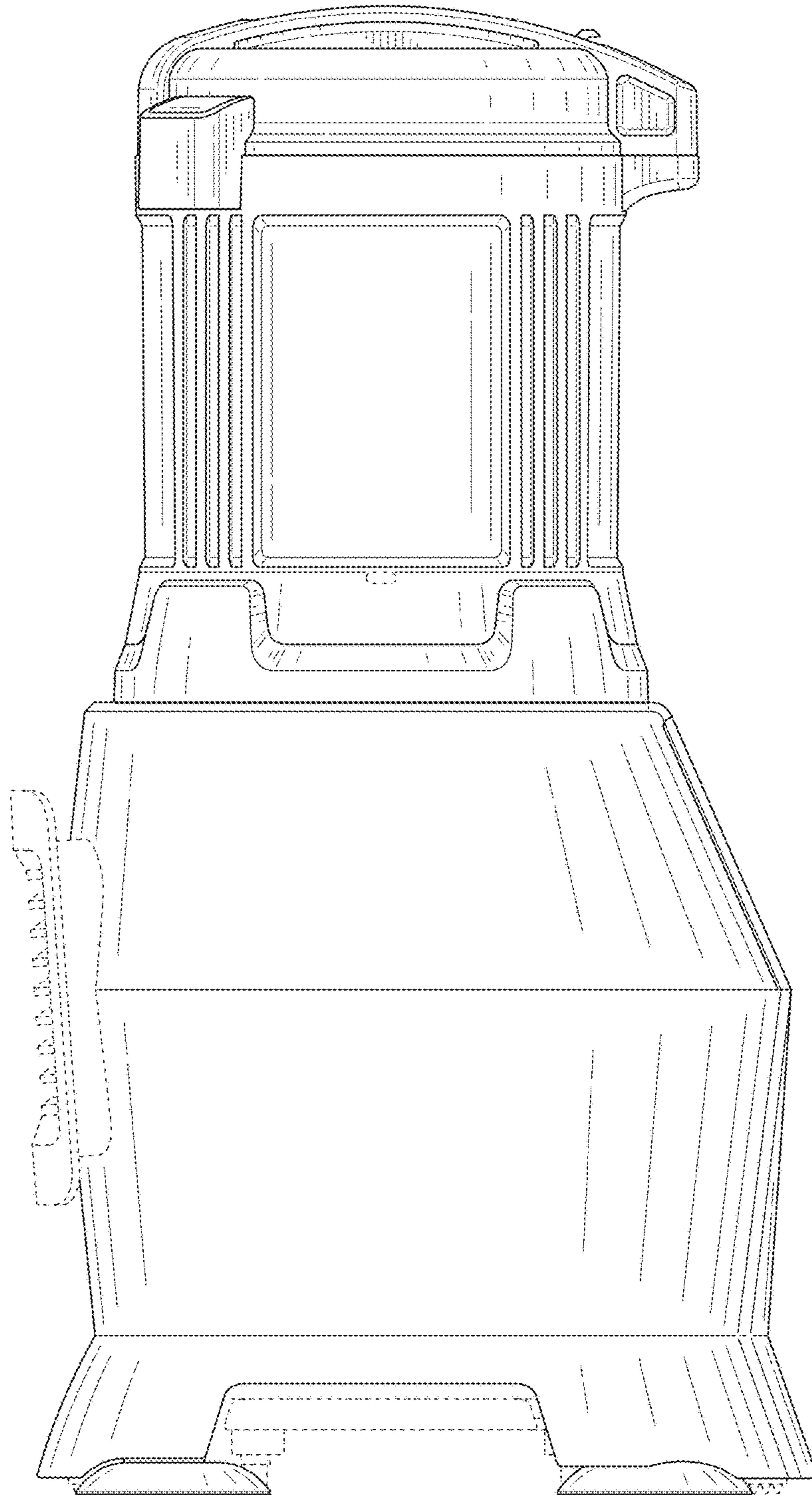

FIG. 11

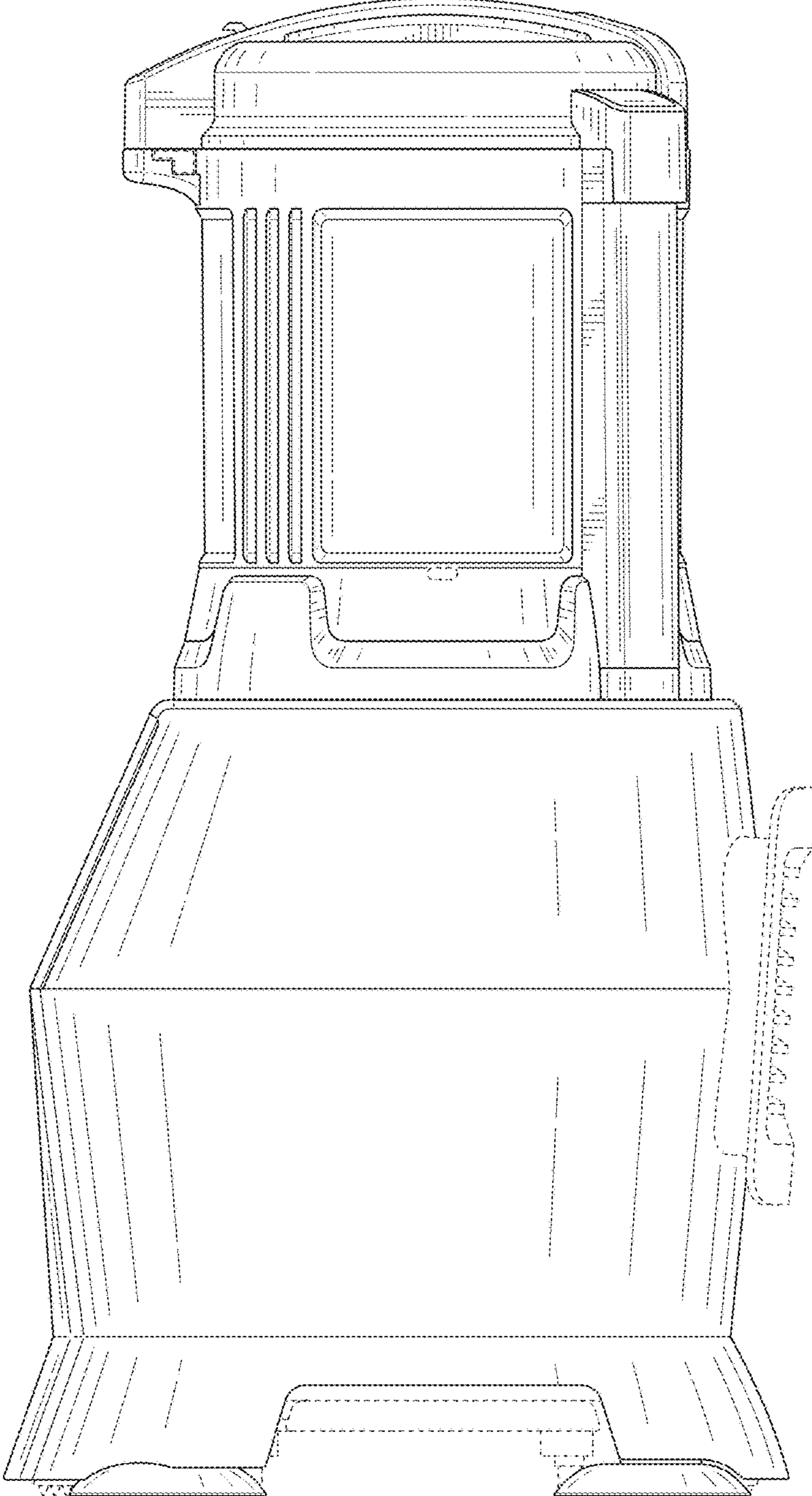

FIG. 12

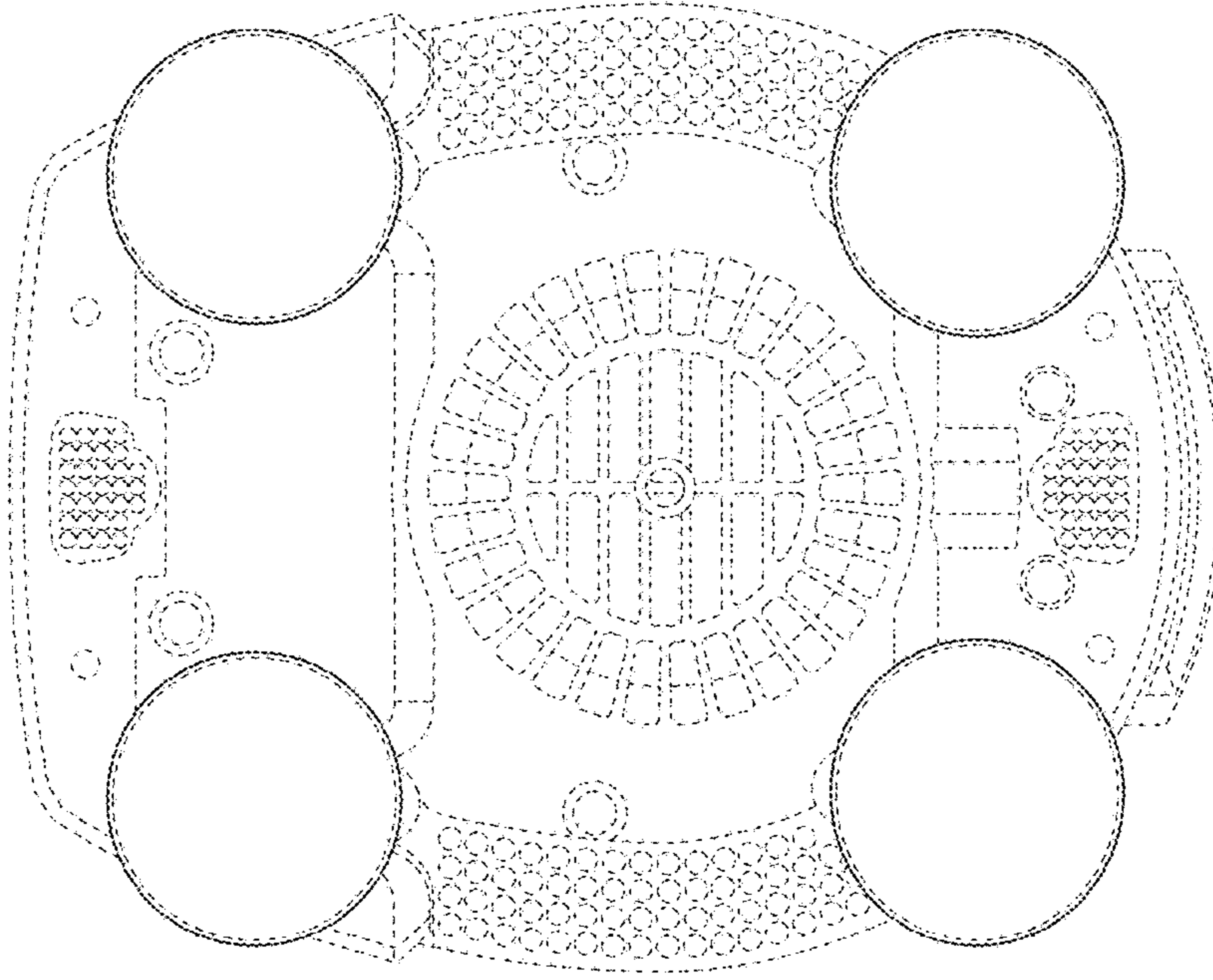

FIG. 14

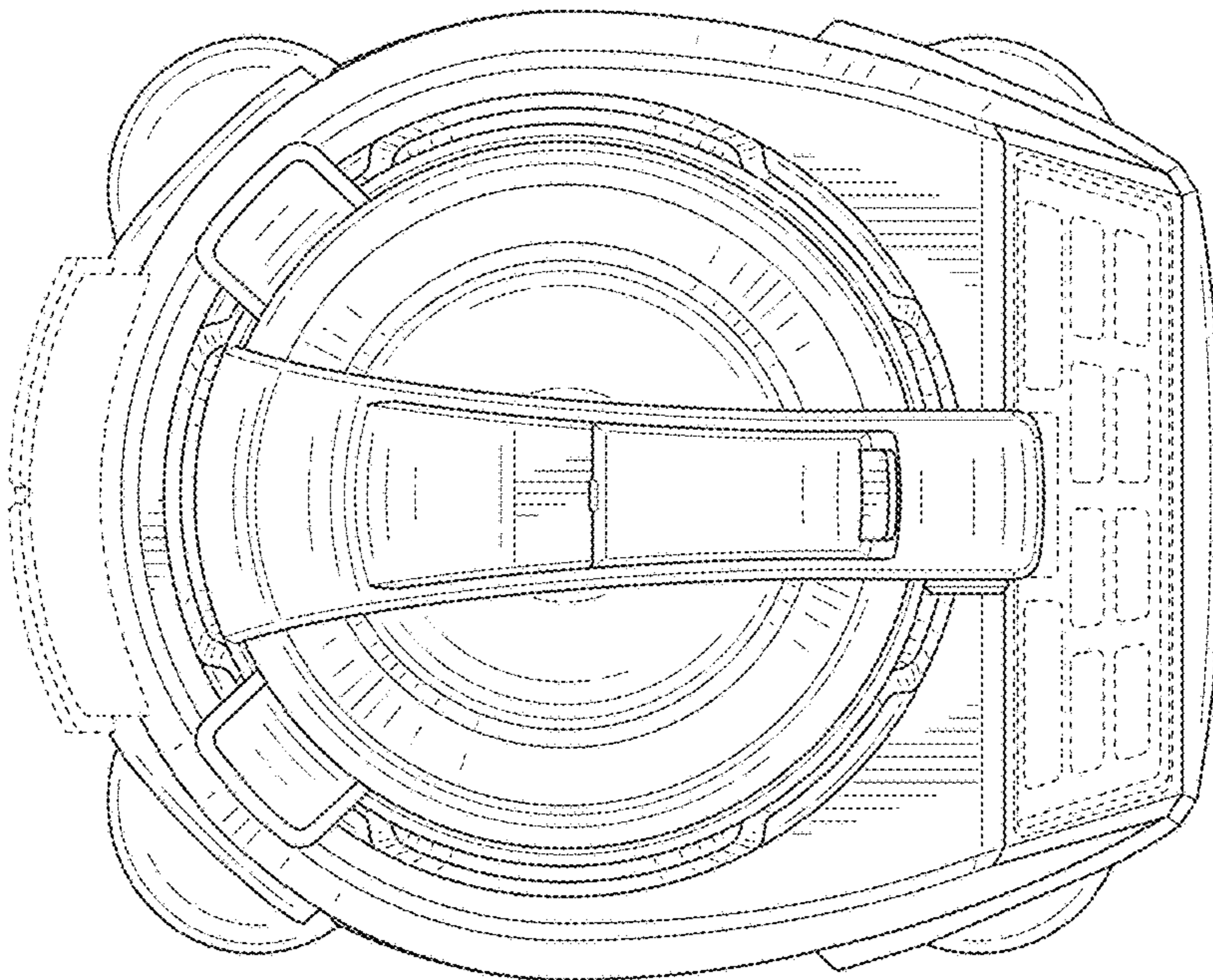

FIG. 13