



US00D839506S

(12) **United States Design Patent**  
**Ha et al.**

(10) **Patent No.: US D839,506 S**

(45) **Date of Patent: \*\* \*Jan. 29, 2019**

(54) **WASHING MACHINE**

(56) **References Cited**

(71) Applicant: **LG ELECTRONICS INC.**, Seoul (KR)

U.S. PATENT DOCUMENTS

(72) Inventors: **Youngsoo Ha**, Seoul (KR); **Taewoo Yoo**, Seoul (KR); **Eunyoung Chee**, Seoul (KR); **Jeaseok Seong**, Seoul (KR)

D521,197 S *	5/2006	Kim .....	D32/8
D549,901 S *	8/2007	Kwon .....	D32/6
D589,216 S *	3/2009	Park .....	D32/6
D617,960 S *	6/2010	Bohm .....	D32/6
D680,281 S *	4/2013	Qin .....	D32/6
D692,194 S *	10/2013	Meda .....	D32/6
D695,472 S *	12/2013	Borjesson .....	D32/6
D695,978 S *	12/2013	Lee .....	D32/6
D764,722 S *	8/2016	Jo .....	D32/6
D770,706 S *	11/2016	Ha .....	D32/6
D773,755 S *	12/2016	Hwang .....	D32/6
D781,004 S *	3/2017	Lee .....	D32/6
D806,329 S *	12/2017	Carlehed .....	D32/6

(73) Assignee: **LG ELECTRONICS INC.**, Seoul (KR)

(\*) Notice: This patent is subject to a terminal disclaimer.

(\*\*) Term: **15 Years**

\* cited by examiner

(21) Appl. No.: **35/502,578**

*Primary Examiner* — Michael A. Pratt

(22) Filed: **Sep. 8, 2016**

(74) *Attorney, Agent, or Firm* — Birch, Stewart, Kolasch & Birch, LLP

(80) **Hague Agreement Data**

Int. Filing Date: **Sep. 8, 2016**  
Int. Reg. No.: **DM/092477**  
Int. Reg. Date: **Sep. 8, 2016**  
Int. Reg. Pub. Date: **Mar. 10, 2017**

(57) **CLAIM**

The ornamental design for a washing machine, as shown and described.

(30) **Foreign Application Priority Data**

**DESCRIPTION**

Mar. 16, 2016 (KR) ..... 30-2016-0012197

(51) **LOC (11) Cl.** ..... **15-05**

(52) **U.S. Cl.**  
USPC ..... **D32/6**

(58) **Field of Classification Search**  
USPC ..... D32/5, 6, 8  
CPC ..... D06F 39/045; D06F 29/00; D06F 29/005;  
D06F 25/00; D06F 39/022; D06F 33/02;  
D06F 2204/065; D06F 35/006

1. Washing machine
- 1.1 is a perspective view of a washing machine, showing our new design;
- 1.2 is a front elevation view thereof;
- 1.3 is a rear elevation view thereof;
- 1.4 is a left-side elevation view thereof;
- 1.5 is a right-side elevation view thereof;
- 1.6 is a top plan view thereof; and
- 1.7 is a bottom plan view thereof.

See application file for complete search history.

**1 Claim, 7 Drawing Sheets**

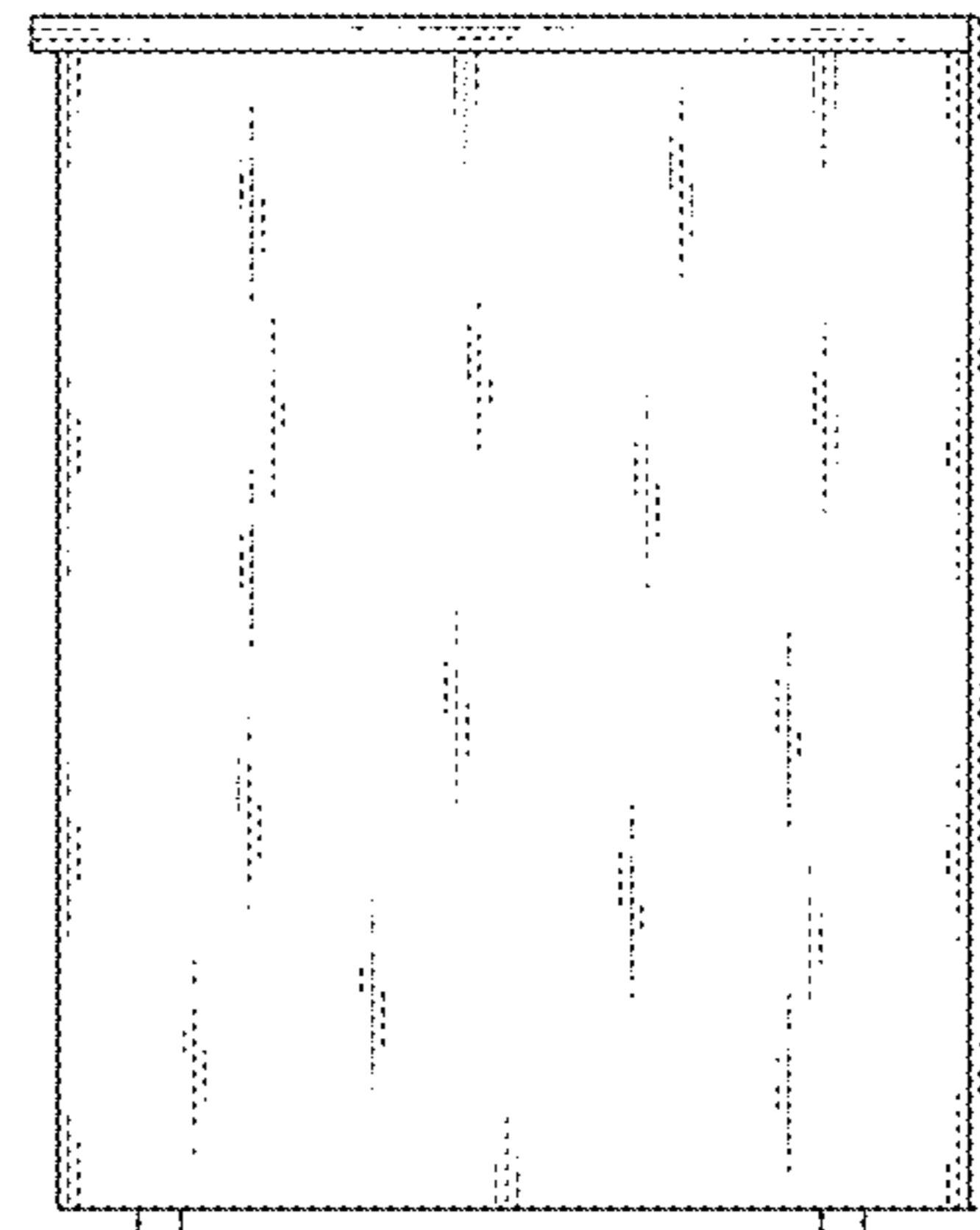
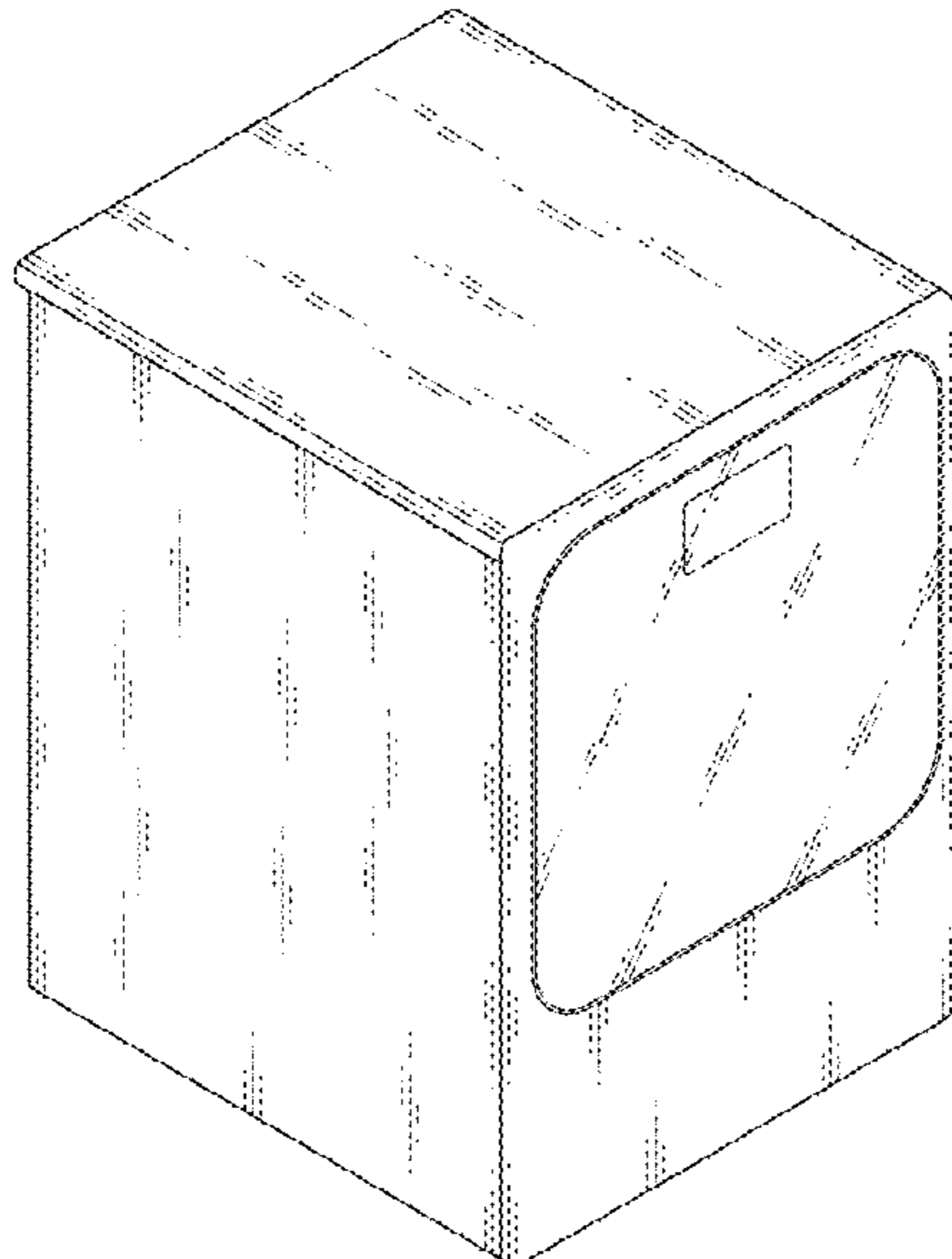

1.1

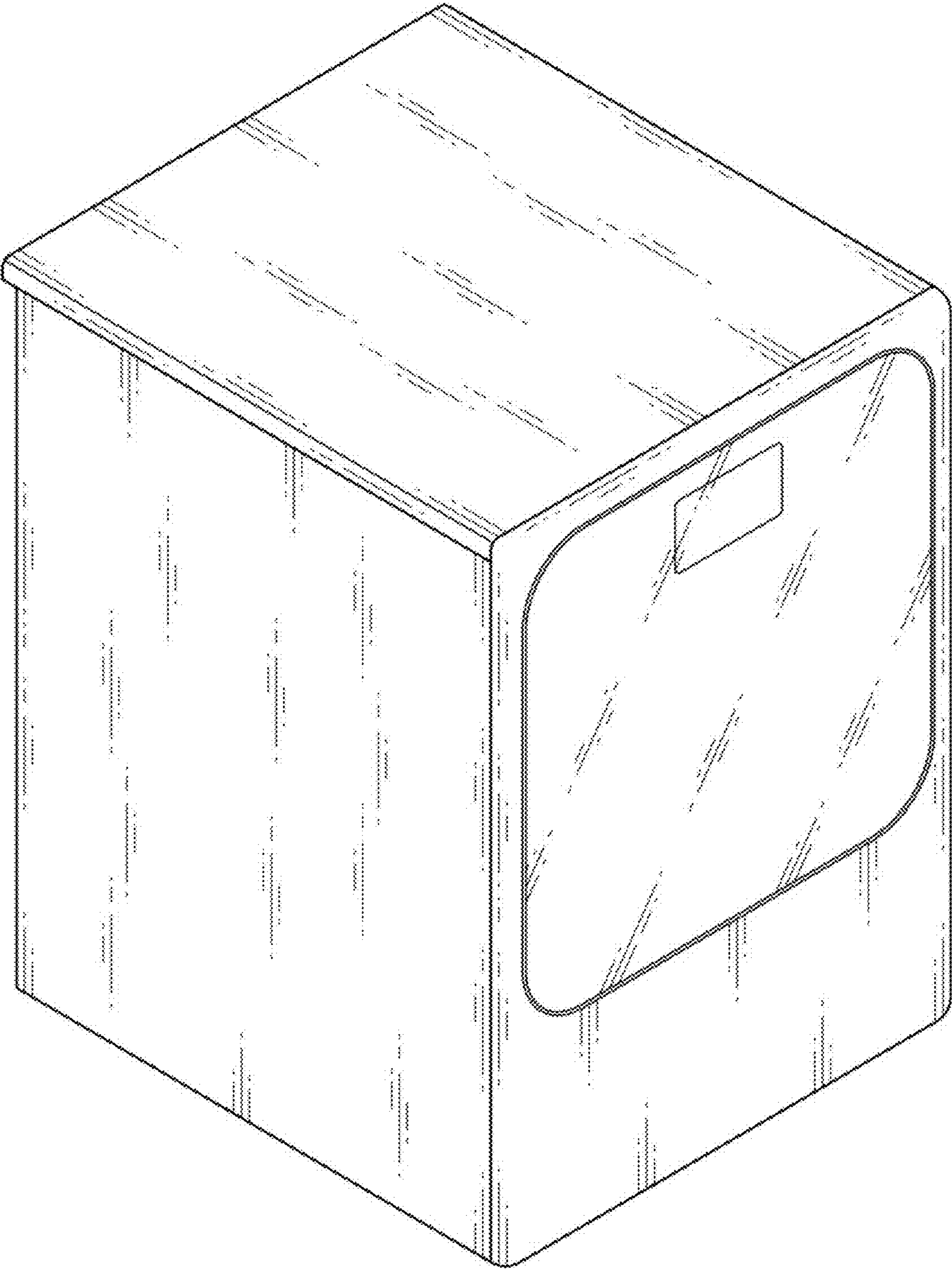

1.2

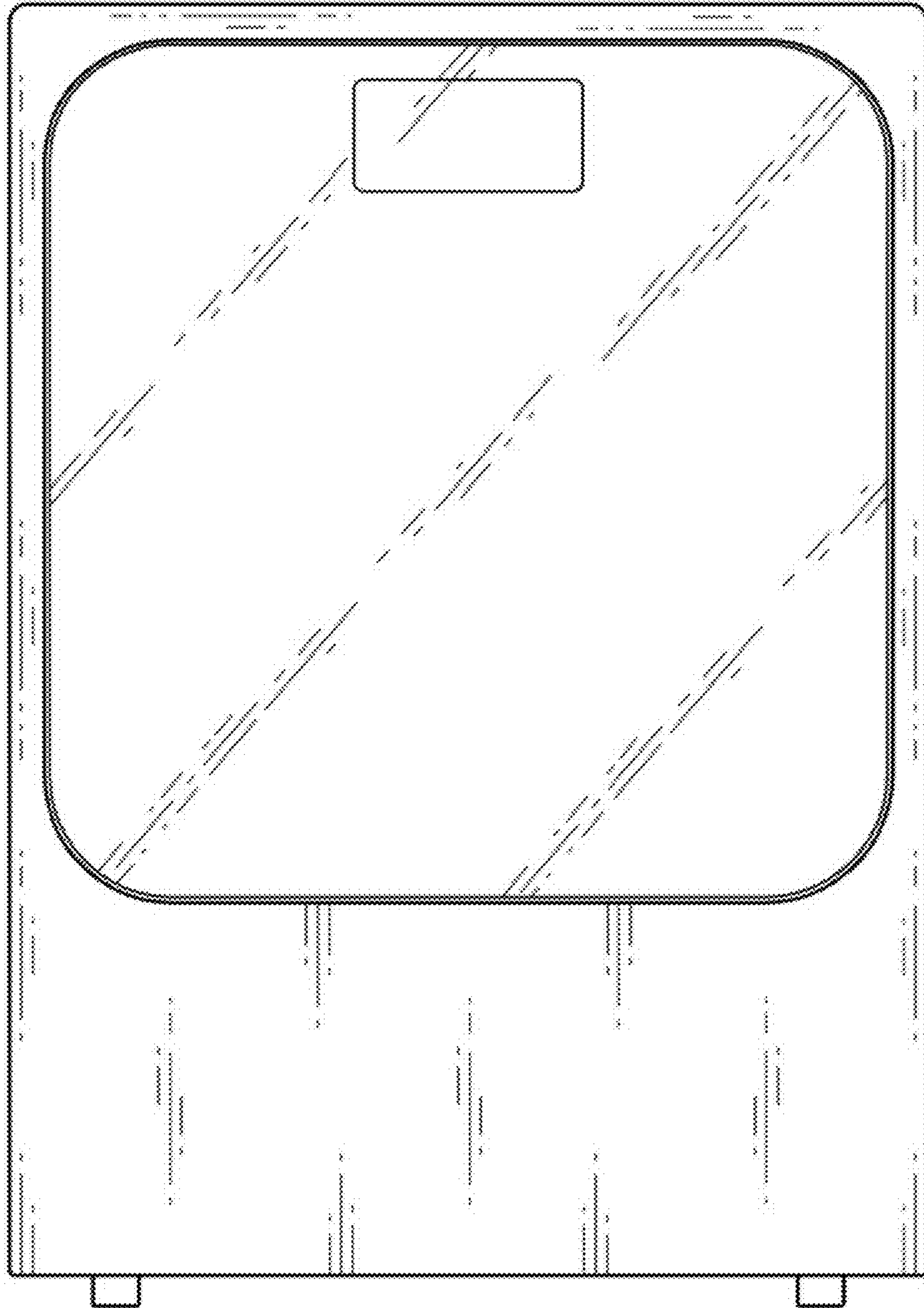

1.3

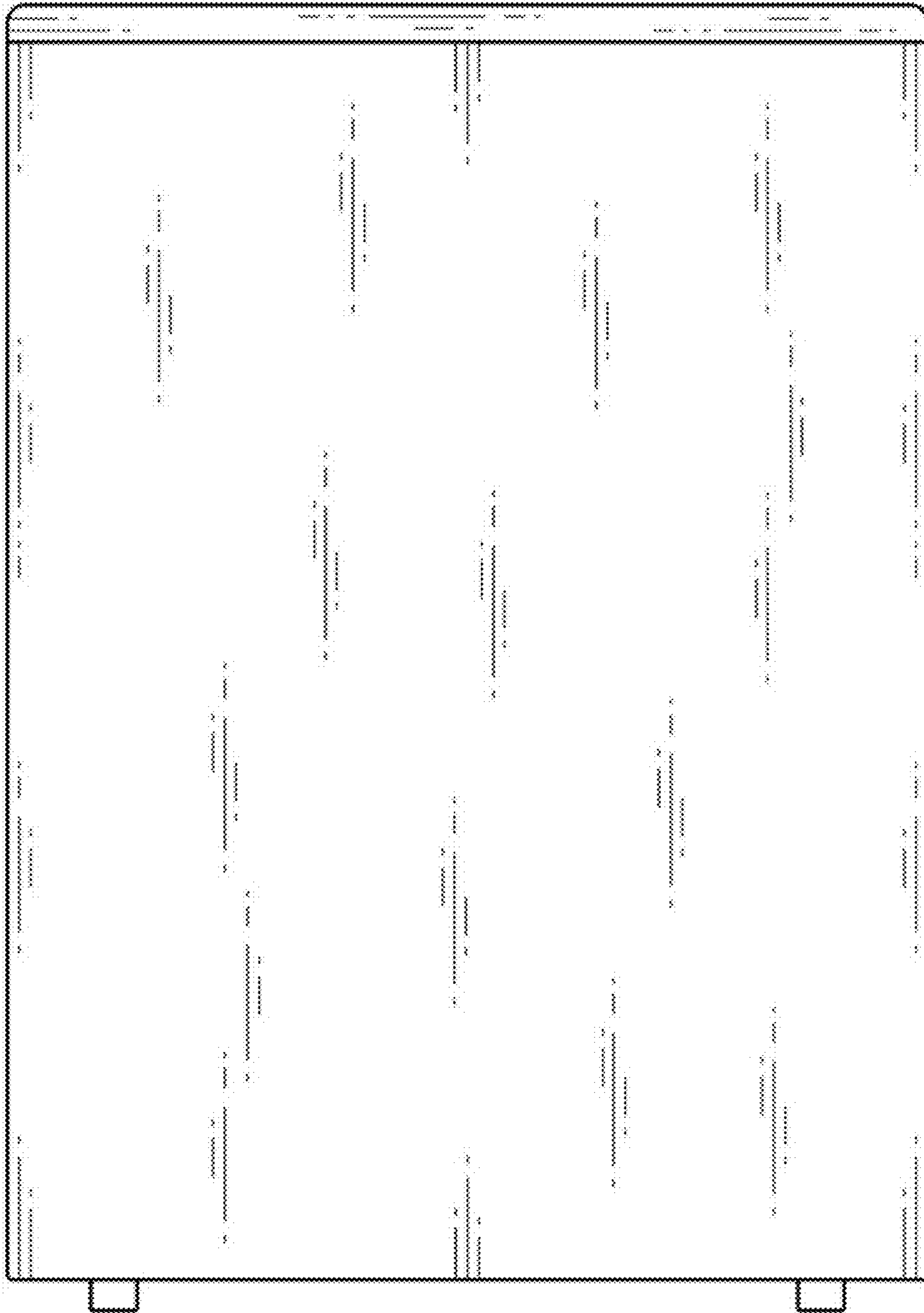

1.4

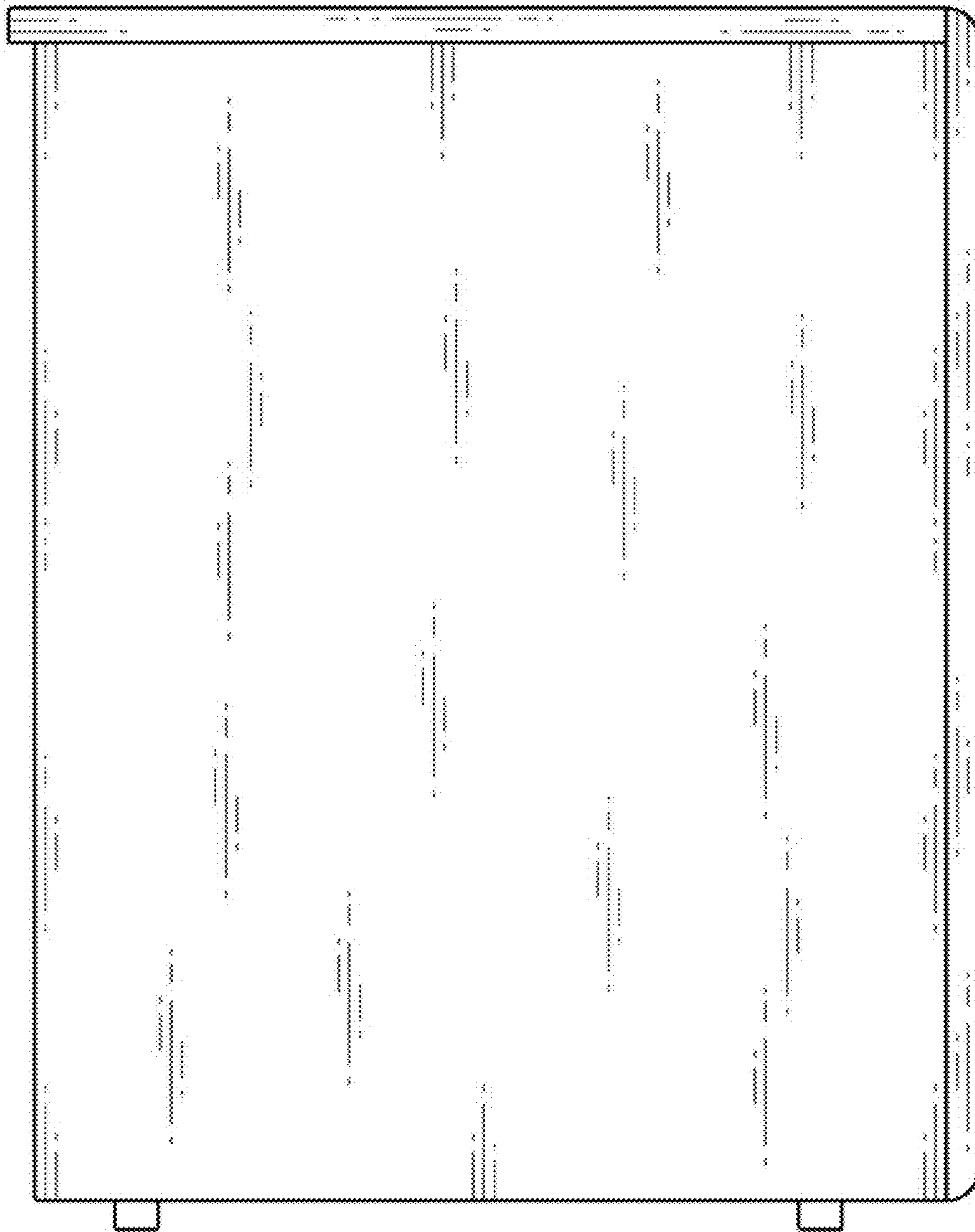

1.5

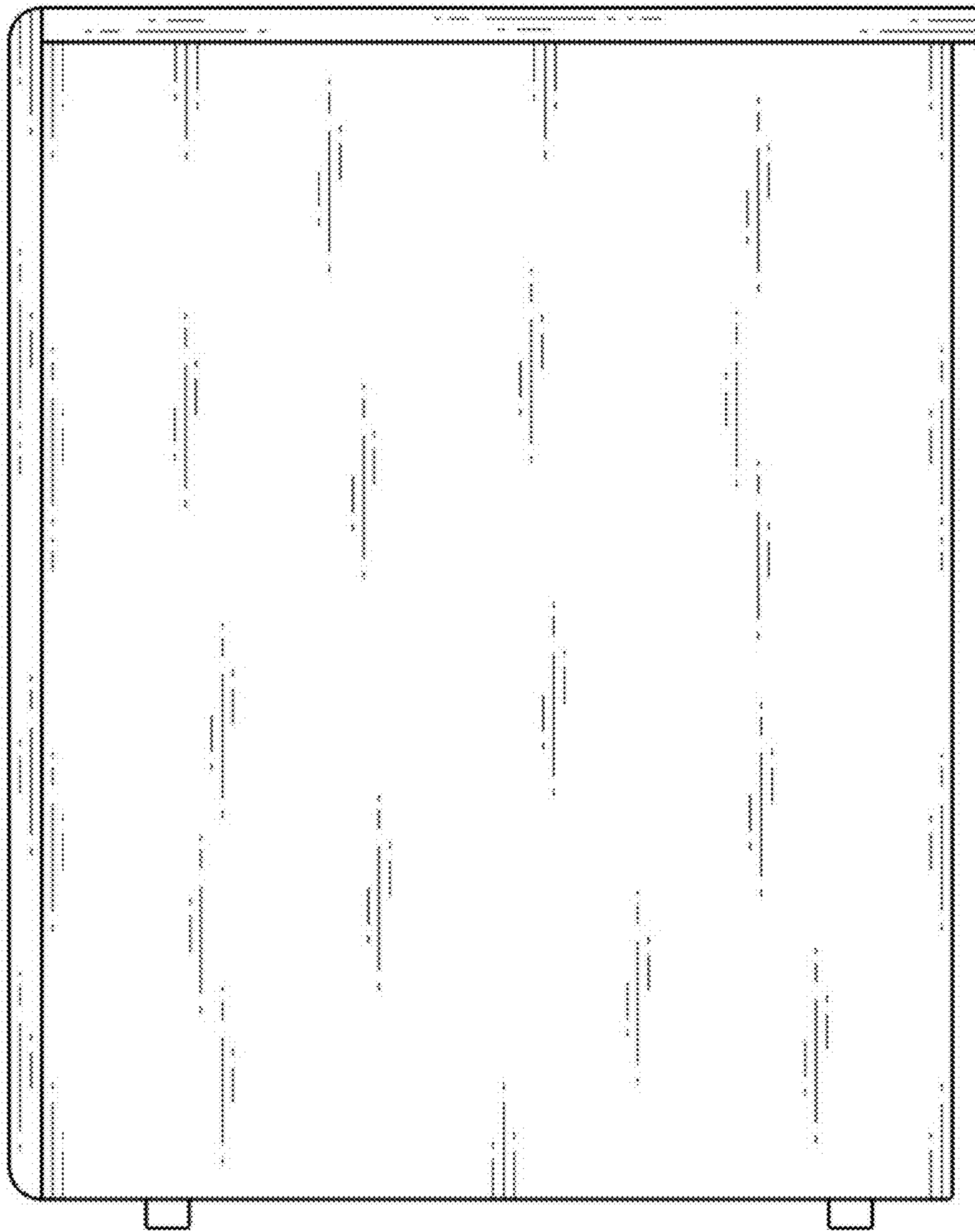

1.6

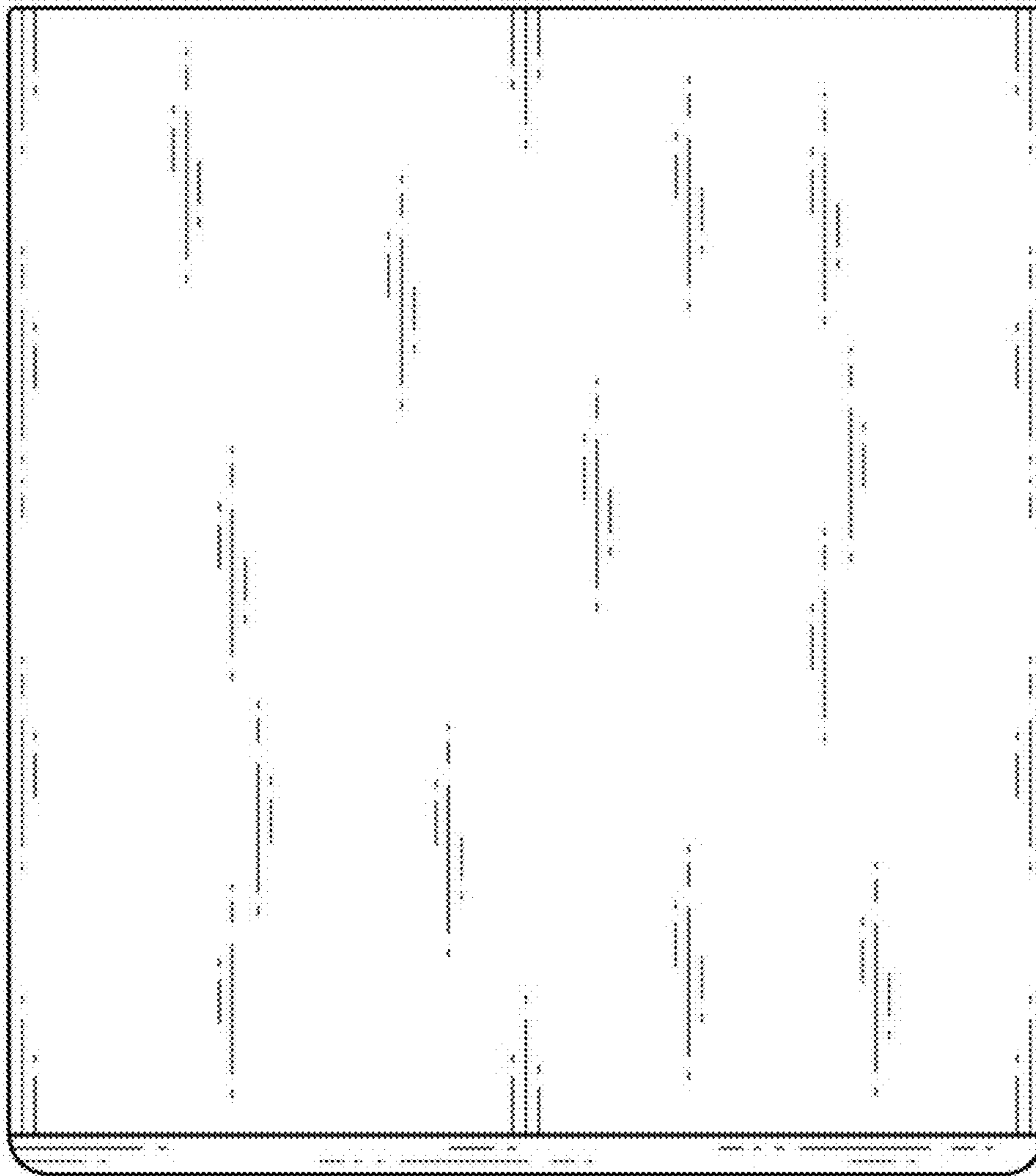

1.7

