



US00D838626S

(12) **United States Design Patent**  
**Matula**

(10) **Patent No.:** **US D838,626 S**  
(45) **Date of Patent:** **\*\* Jan. 22, 2019**

(54) **VASE BRACE**

(71) Applicant: **Catherine Matula**, Mount Prospect, IL (US)

(72) Inventor: **Catherine Matula**, Mount Prospect, IL (US)

(\*\*) Term: **15 Years**

(21) Appl. No.: **29/614,377**

(22) Filed: **Aug. 18, 2017**

(51) **LOC (11) Cl.** ..... **11-02**

(52) **U.S. Cl.**  
USPC ..... **D11/143**

(58) **Field of Classification Search**  
USPC ..... D11/143, 147; D7/388  
CPC ..... A47G 7/07  
See application file for complete search history.

(56) **References Cited**

**U.S. PATENT DOCUMENTS**

1,616,894	A	2/1927	Finlayson	
1,617,352	A *	2/1927	Smith	A47G 7/07 248/167
2,126,766	A	8/1938	Joseph	
3,447,262	A	6/1969	Uhl	
4,842,157	A *	6/1989	Stone-Parker	A47G 19/2211 220/719
5,347,752	A	9/1994	Black	
5,758,452	A	6/1998	Matteucci et al.	
D399,386	S *	10/1998	Goodman	D7/388
D407,944	S *	4/1999	Filbrun	D7/388
6,189,261	B1	2/2001	Helgeson	
D526,595	S *	8/2006	Taddeo	D11/147
D531,543	S *	11/2006	Peter	D6/513
D675,056	S *	1/2013	Goodman	D7/388
D715,097	S *	10/2014	Thonis	D7/388
9,861,218	B1 *	1/2018	Matula	A47G 7/07
2002/0184818	A1	12/2002	Roskin	
2003/0009937	A1	1/2003	Delaney	
2006/0096171	A1 *	5/2006	Taddeo	A47G 7/07 47/41.11

**OTHER PUBLICATIONS**

Mud Pie 4435002 Preserve Mason Jar Vase, Brown, <https://www.amazon.com/Mud-Pie-4435002-Preserve-Mason/dp/B00UW74JR6>.

\* cited by examiner

*Primary Examiner* — Karen S Acker

*Assistant Examiner* — Steven B Reinholdt, Jr.

(74) *Attorney, Agent, or Firm* — Lesley A. Wallerstein, LLC

(57) **CLAIM**

The ornamental design for this vase brace, as shown and described.

**DESCRIPTION**

FIG. 1 is a perspective view of a vase brace according to the present invention. The dotted lines illustrate a representative vase for context, and form no part of the claimed design.

FIG. 2 is an alternative perspective view of the vase brace of FIG. 1. The dotted lines illustrate a representative vase and flowers for context, and form no part of the claimed design.

FIG. 3 is an enlarged detail view thereof.

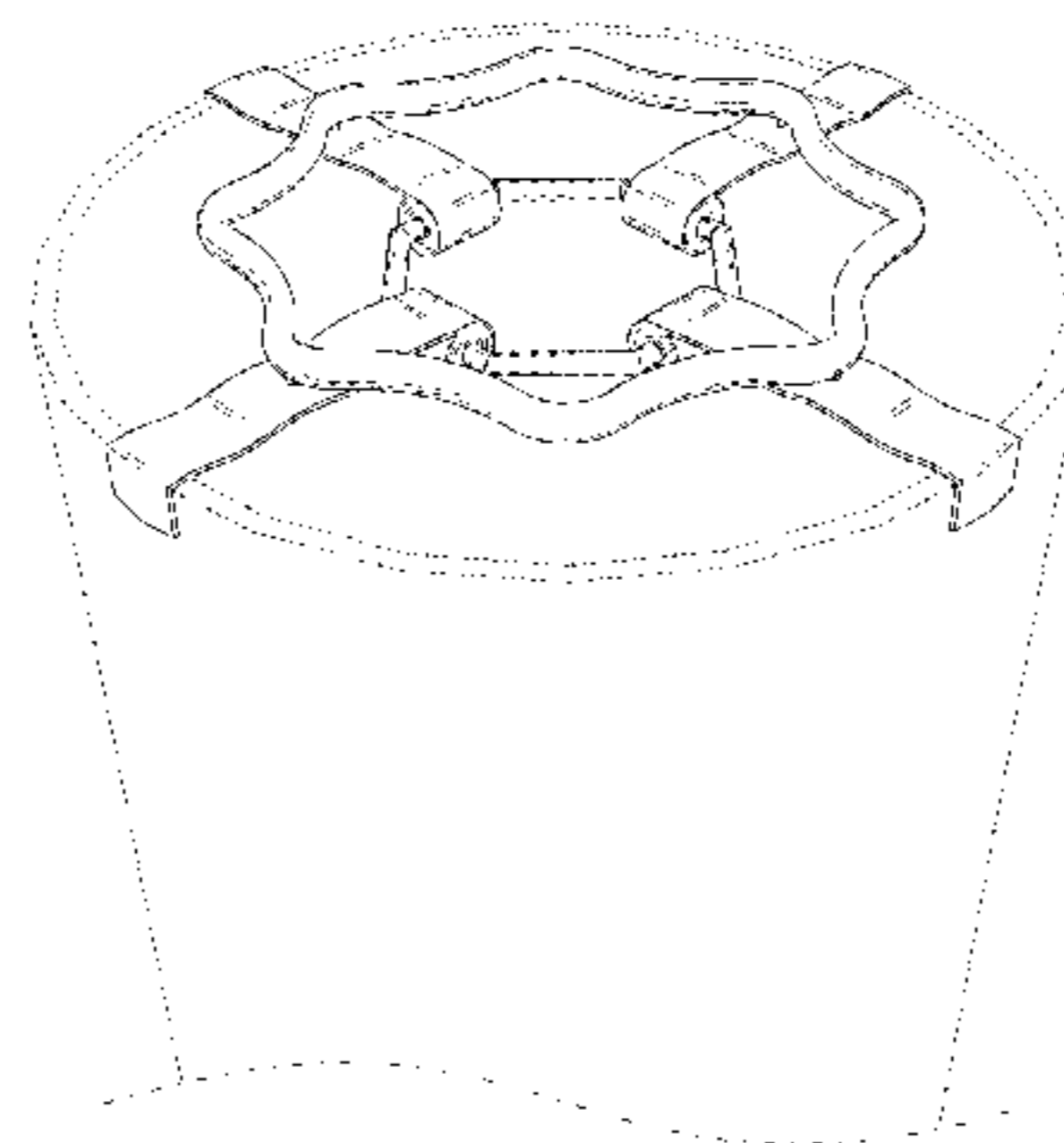
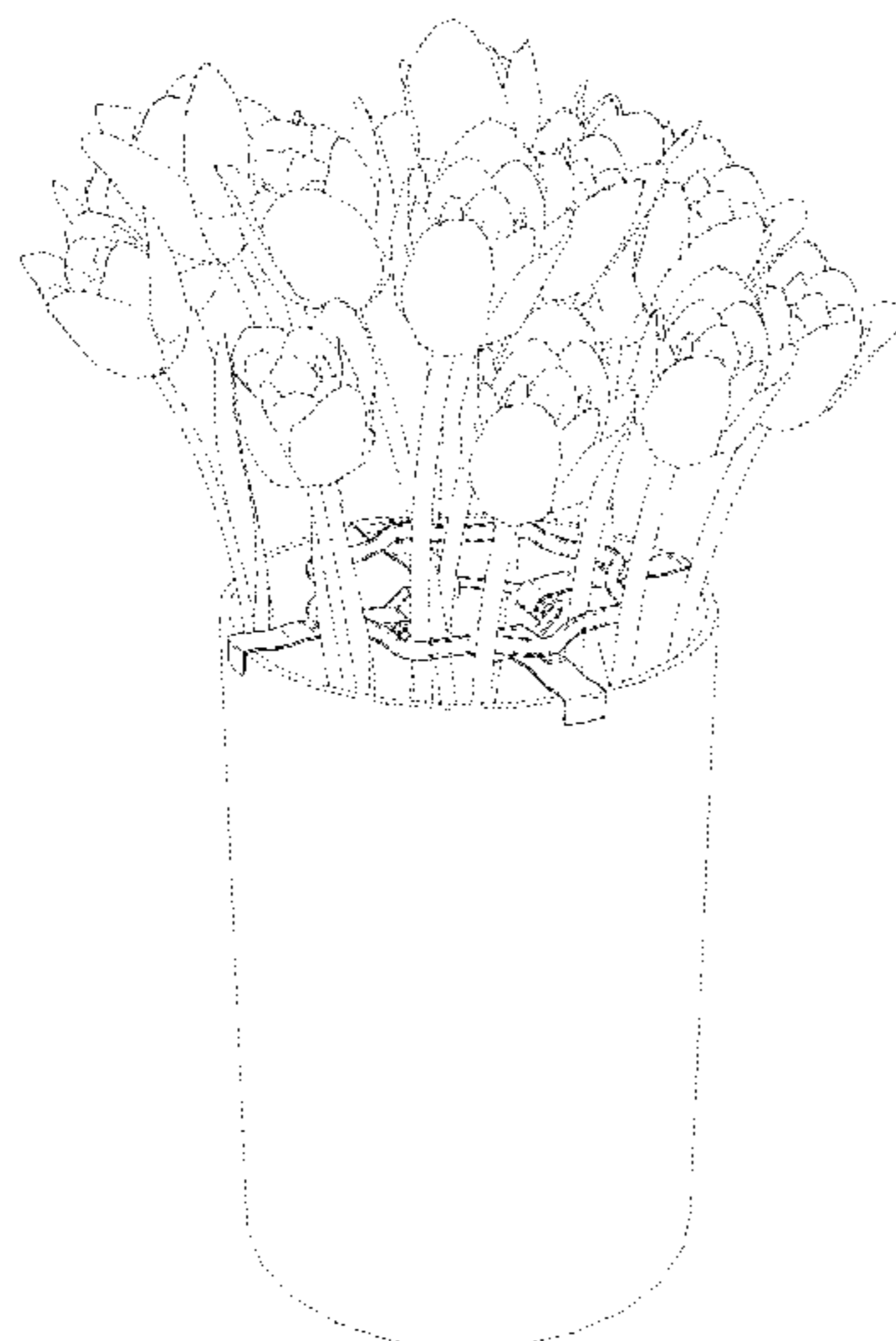
FIG. 4 is a side view of the vase brace of FIG. 1.

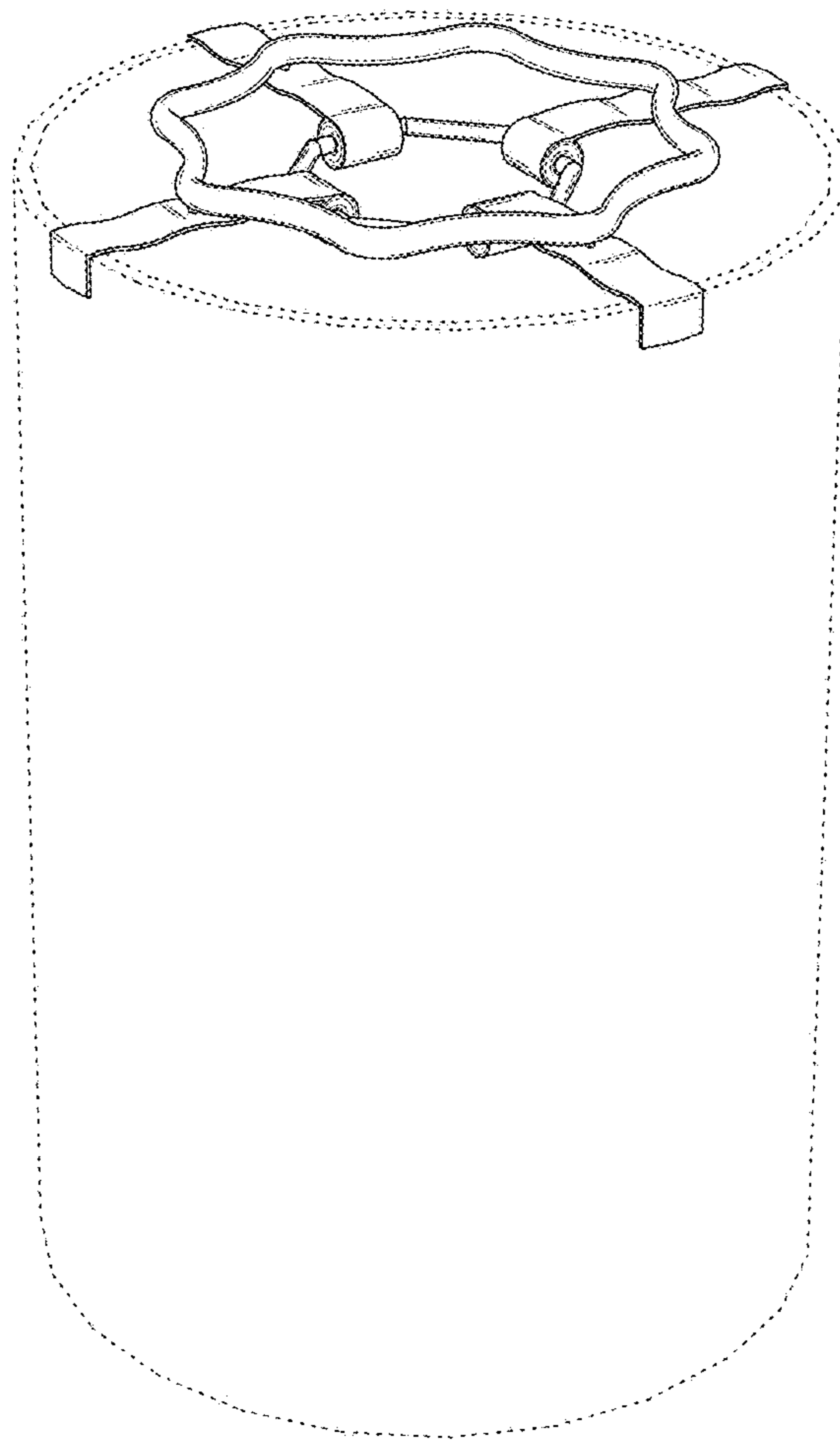
FIG. 5 is a top view of the vase brace of FIG. 1; and,

FIG. 6 is a second alternative perspective view of the vase brace of FIG. 1. The dotted lines illustrate a representative vase for context, and form no part of the claimed design.

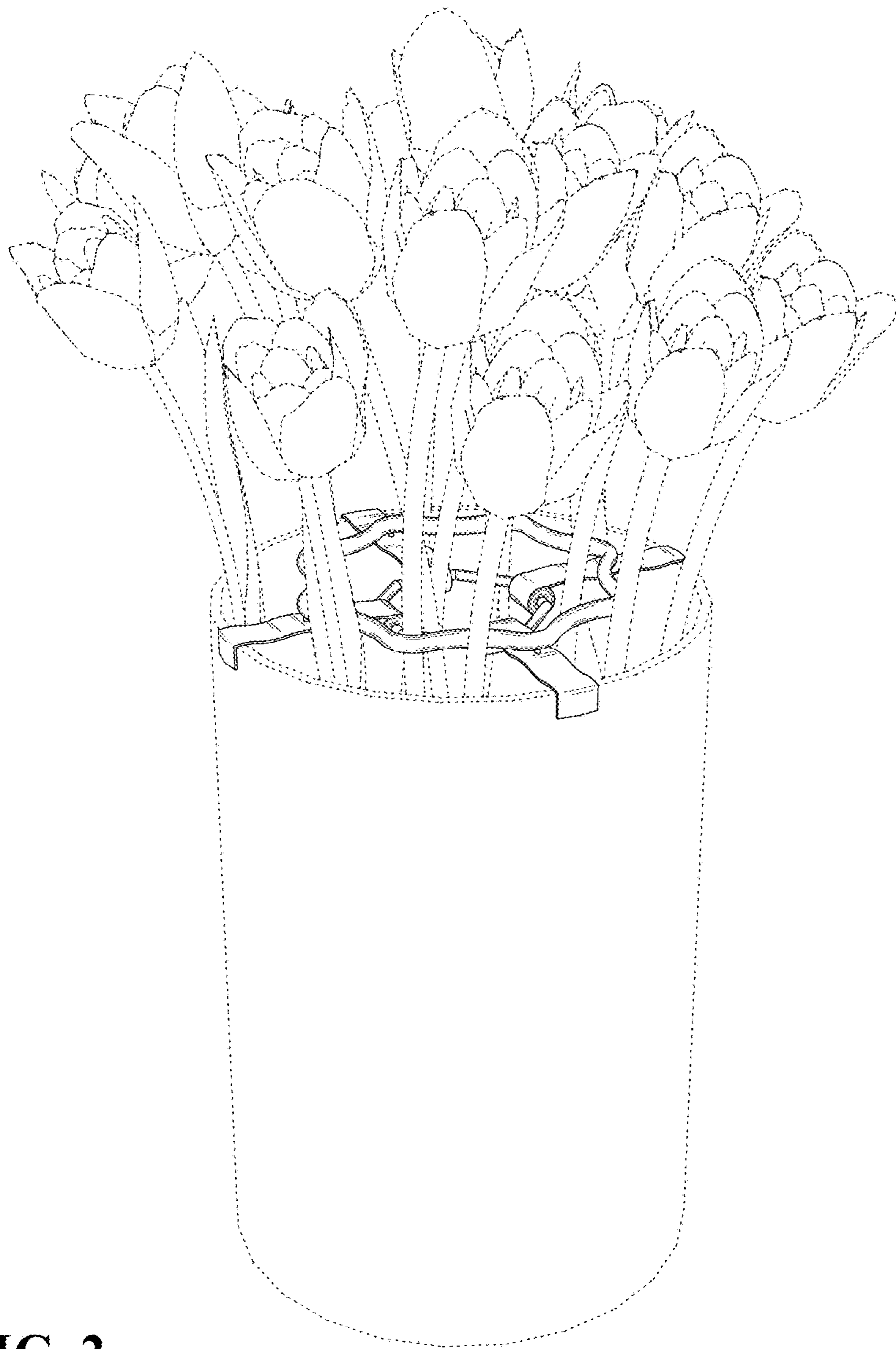
The evenly spaced broken lines depict environmental subject matter that forms no part of the claim. The dot-dash-dot broken lines in FIG. 3 depict an enlargement frame that forms no part of the claimed design. The dot-dash-dot broken line in FIGS. 4 and 6 depicts a symbolic break line that forms no part of the claimed design.

**1 Claim, 6 Drawing Sheets**

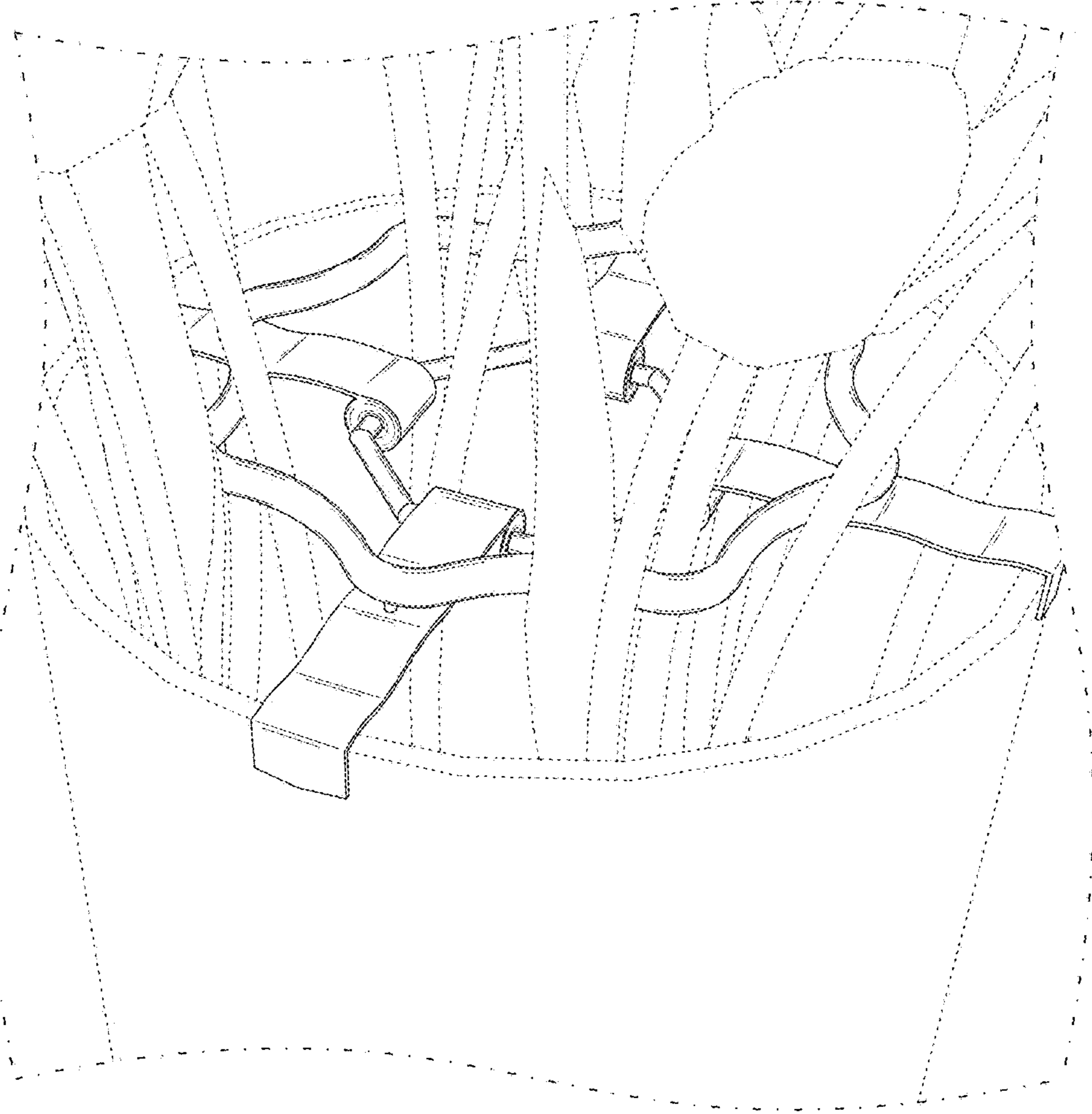




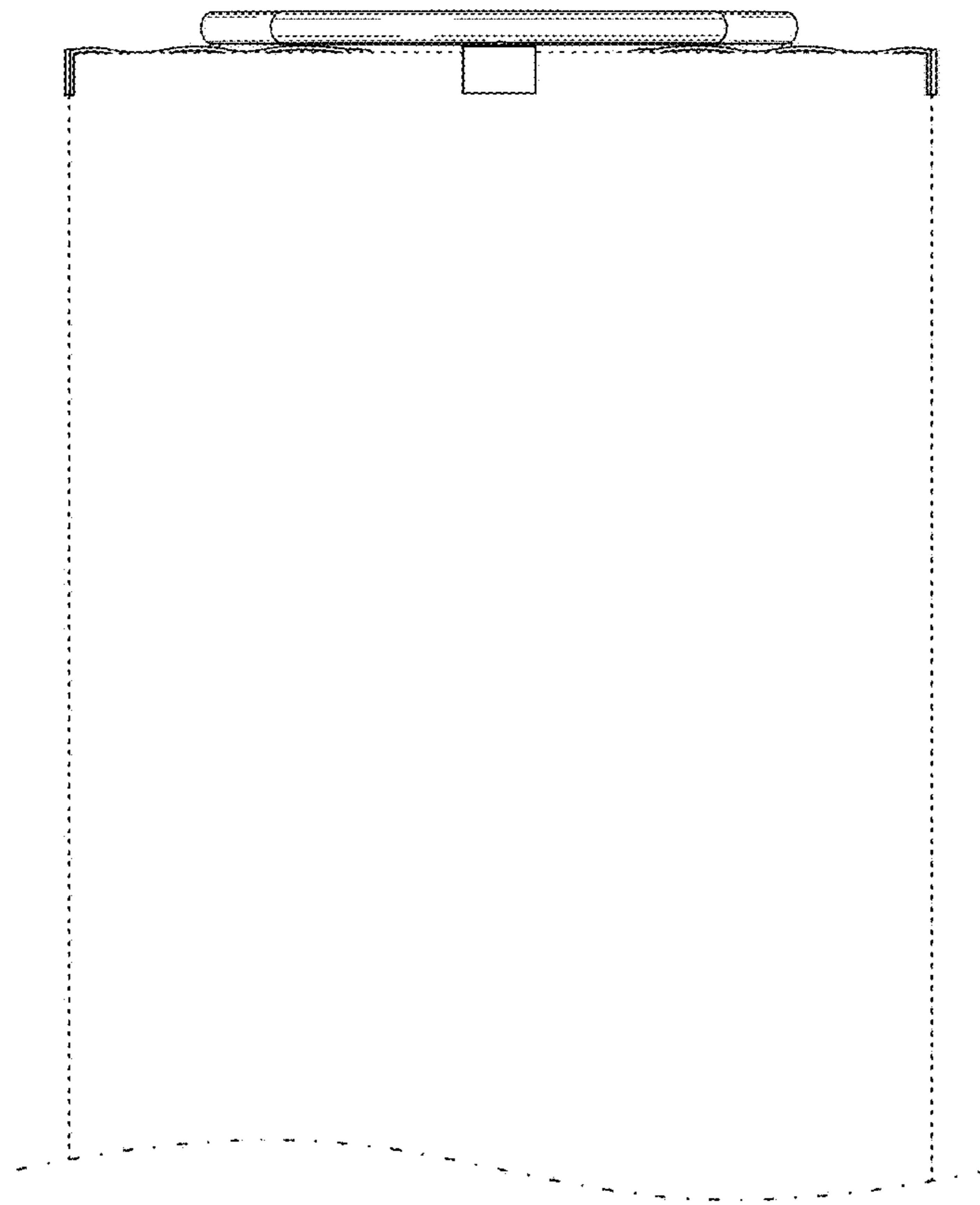
**FIG. 1**



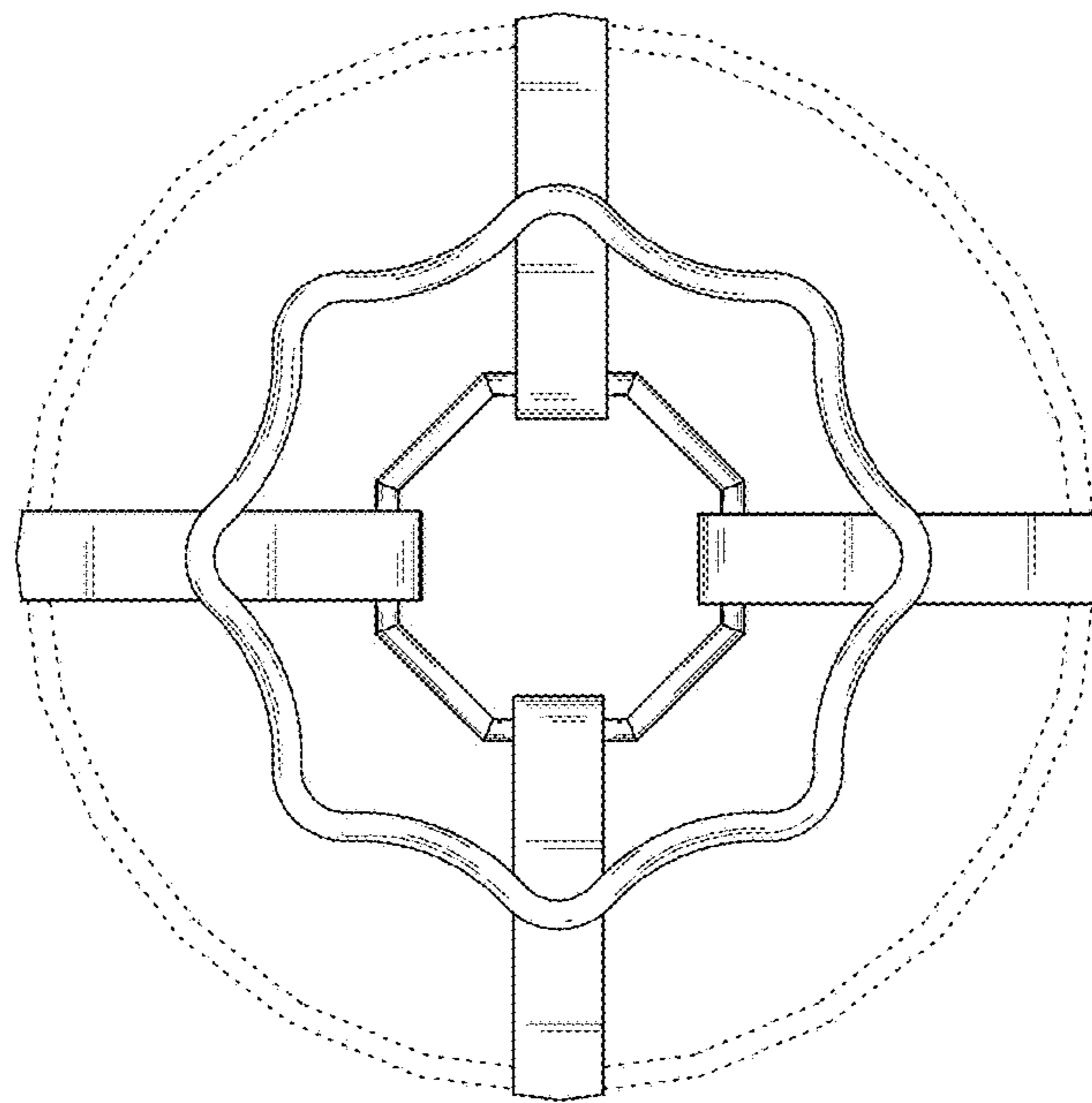
**FIG. 2**



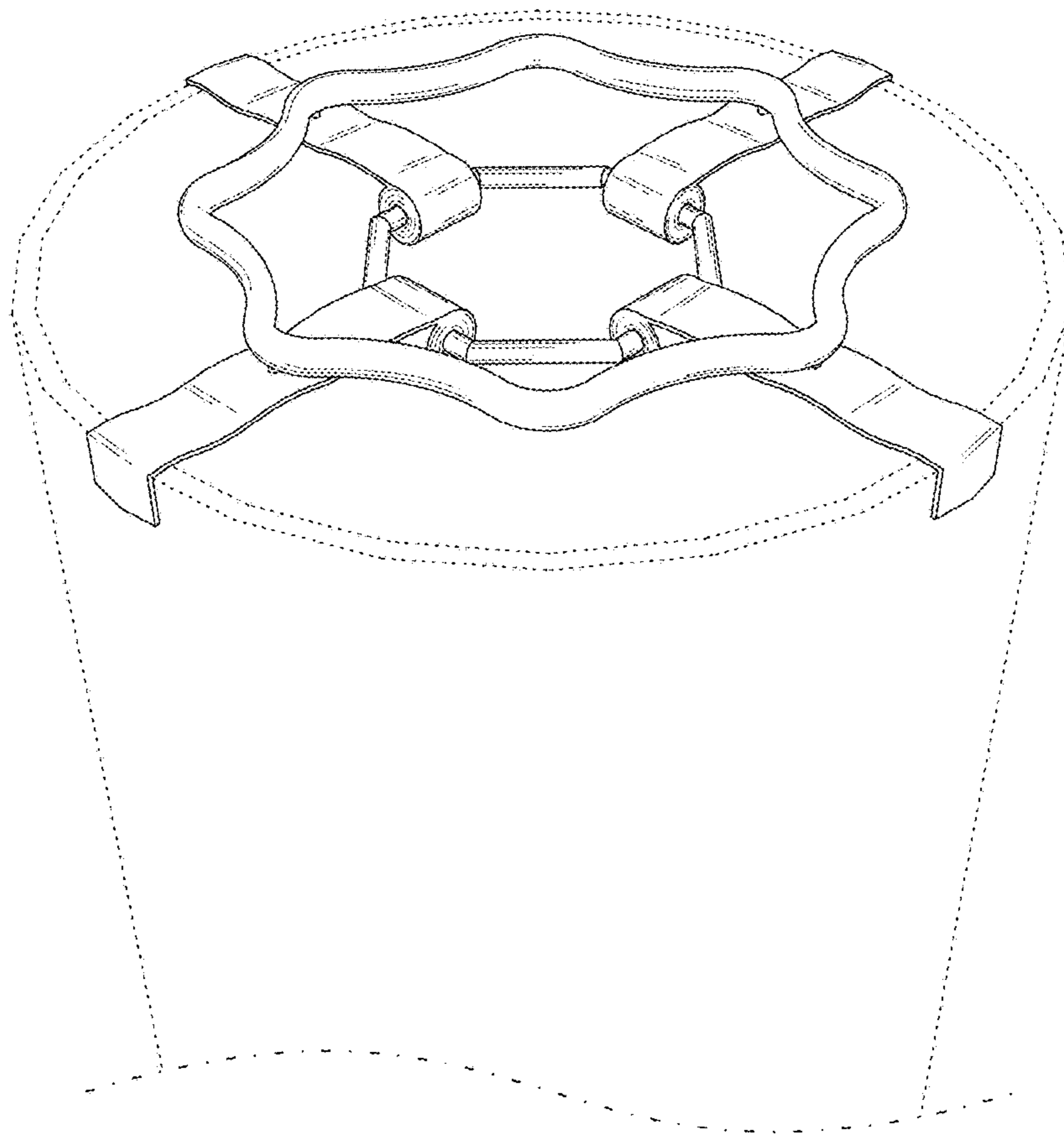
**FIG. 3**



**FIG. 4**



**FIG. 5**



**FIG. 6**