



US00D838424S

(12) **United States Design Patent** (10) **Patent No.:** **US D838,424 S**  
**La Rovere et al.** (45) **Date of Patent:** **\*\* Jan. 15, 2019**

(54) **IRON WITH STEAM GENERATOR**

(71) Applicant: **KONINKLIJKE PHILIPS N.V.**,  
Eindhoven (NL)

(72) Inventors: **Massimiliano La Rovere**, Singapore  
(SG); **Xue Xiao**, Singapore (SG)

(73) Assignee: **KONINKLIJKE PHILIPS N.V.**,  
Eindhoven (NL)

(\*\*) Term: **15 Years**

(21) Appl. No.: **35/503,318**

(22) Filed: **Jan. 3, 2017**

(80) **Hague Agreement Data**

Int. Filing Date: **Jan. 3, 2017**  
 Int. Reg. No.: **DM/094327**  
 Int. Reg. Date: **Jan. 3, 2017**  
 Int. Reg. Pub. Date: **Jul. 7, 2017**

(30) **Foreign Application Priority Data**

Jul. 20, 2016 (EM) ..... 003312537-0001  
 Jul. 20, 2016 (EM) ..... 003312537-0002

(51) **LOC (11) Cl.** ..... **07-05**

(52) **U.S. Cl.**  
USPC ..... **D32/68**

(58) **Field of Classification Search**  
 USPC ..... D32/17, 68, 70, 73  
 CPC ..... D06F 75/30; D06F 75/36; D06F 75/10;  
 D06F 87/00  
 See application file for complete search history.

(56) **References Cited**

**U.S. PATENT DOCUMENTS**

D656,693 S \* 3/2012 Lavy ..... D32/17  
 D660,538 S \* 5/2012 Smith ..... D32/71

D667,600 S \* 9/2012 Smith ..... D32/70  
 D693,083 S \* 11/2013 Smith ..... D32/71  
 D701,362 S \* 3/2014 Smith ..... D32/70  
 D707,007 S \* 6/2014 Smith ..... D32/70  
 D714,007 S \* 9/2014 La Rovere ..... D32/70  
 D738,058 S \* 9/2015 La Rovere ..... D32/70  
 D738,060 S \* 9/2015 La Rovere ..... D32/71  
 D738,586 S \* 9/2015 La Rovere ..... D32/70  
 D738,587 S \* 9/2015 La Rovere ..... D32/71  
 D739,629 S \* 9/2015 Luang ..... D32/70  
 D759,330 S \* 6/2016 Luang ..... D32/71  
 D789,011 S \* 6/2017 Koehler ..... D32/70  
 D798,008 S \* 9/2017 Malatray ..... D32/17

**OTHER PUBLICATIONS**

Online reviews of Philips PerfectCare Elite Silence GC9642, earliest date Dec. 2013, 18 pages.. Found online Jun. 4, 2018 at <https://www.productreview.com.au/p/philips-perfectcare-elite-silence-gc9642.html> (Year: 2013).\*

\* cited by examiner

*Primary Examiner* — Robert M. Spear

(57) **CLAIM**

The ornamental design for an iron with steam generator, as shown and described.

**DESCRIPTION**

1. Iron with steam generator  
**1.1** is a perspective view showing the iron with steam generator of our design;  
**1.2** is a front elevational view thereof;  
**1.3** is a rear elevational view thereof;  
**1.4** is a left side elevational view thereof;  
**1.5** is a right side elevational view thereof;  
**1.6** is a top plan view thereof; and  
**1.7** is a bottom plan view thereof.

**1 Claim, 7 Drawing Sheets**

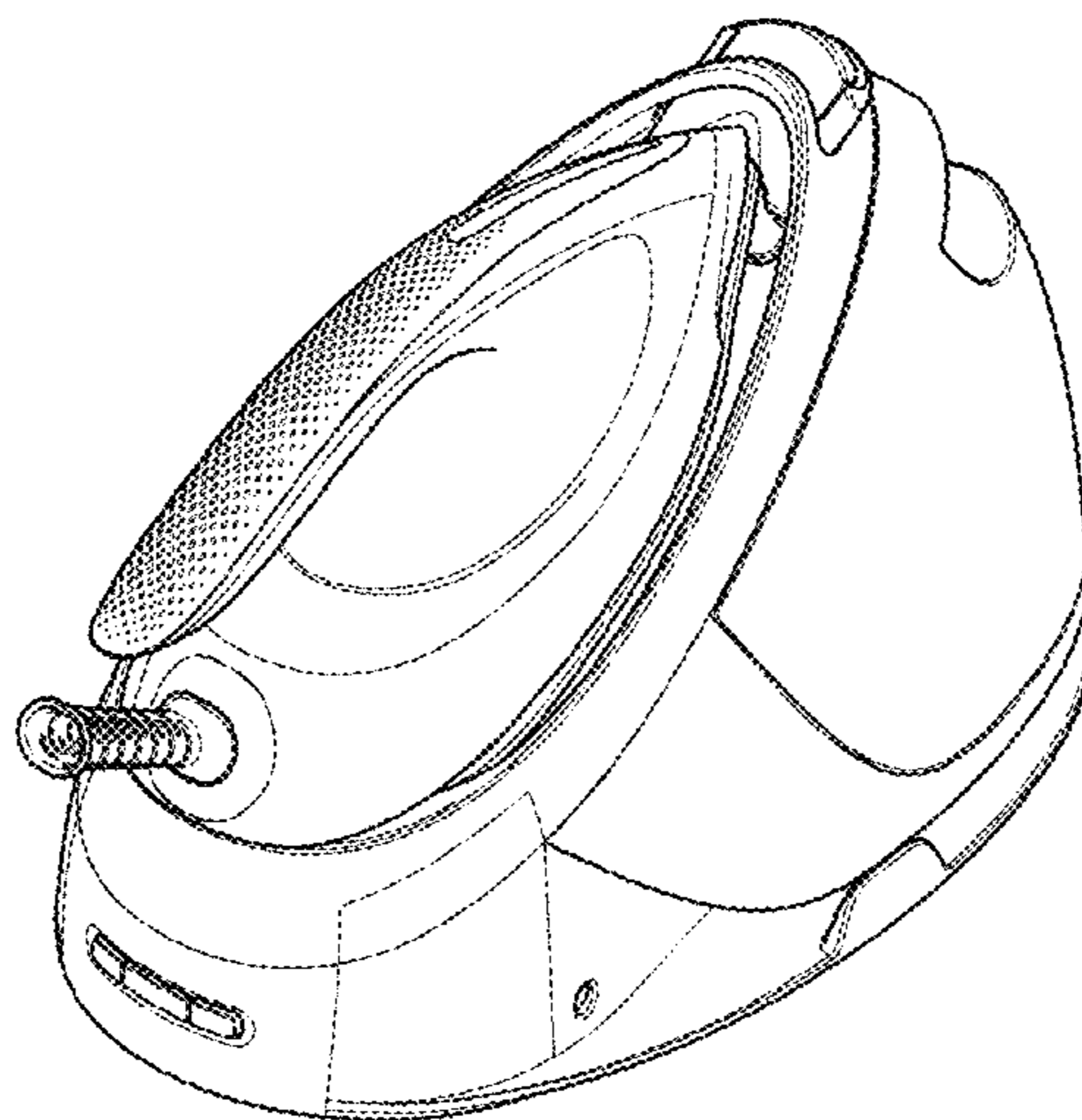

1.1

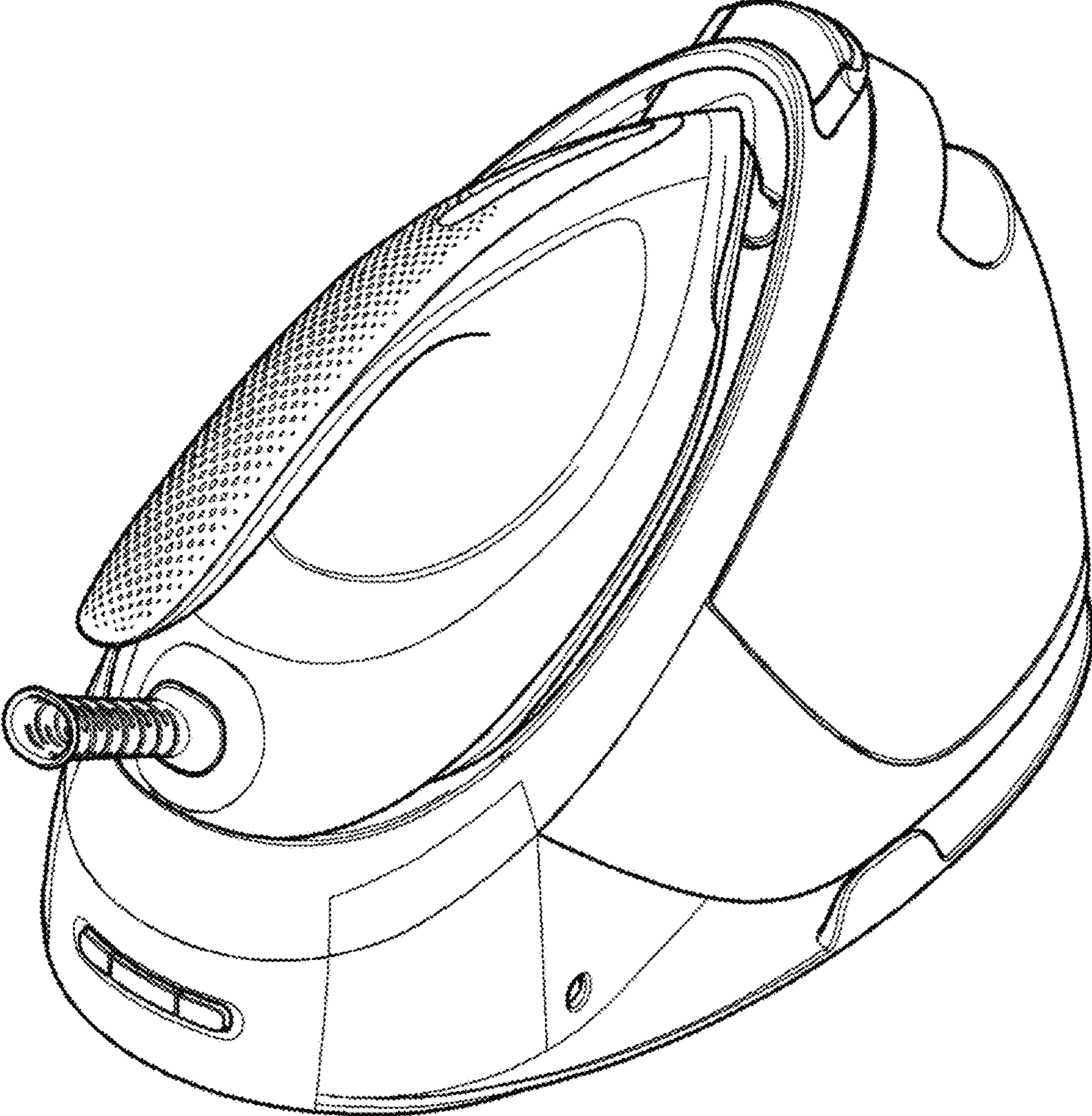

1.2

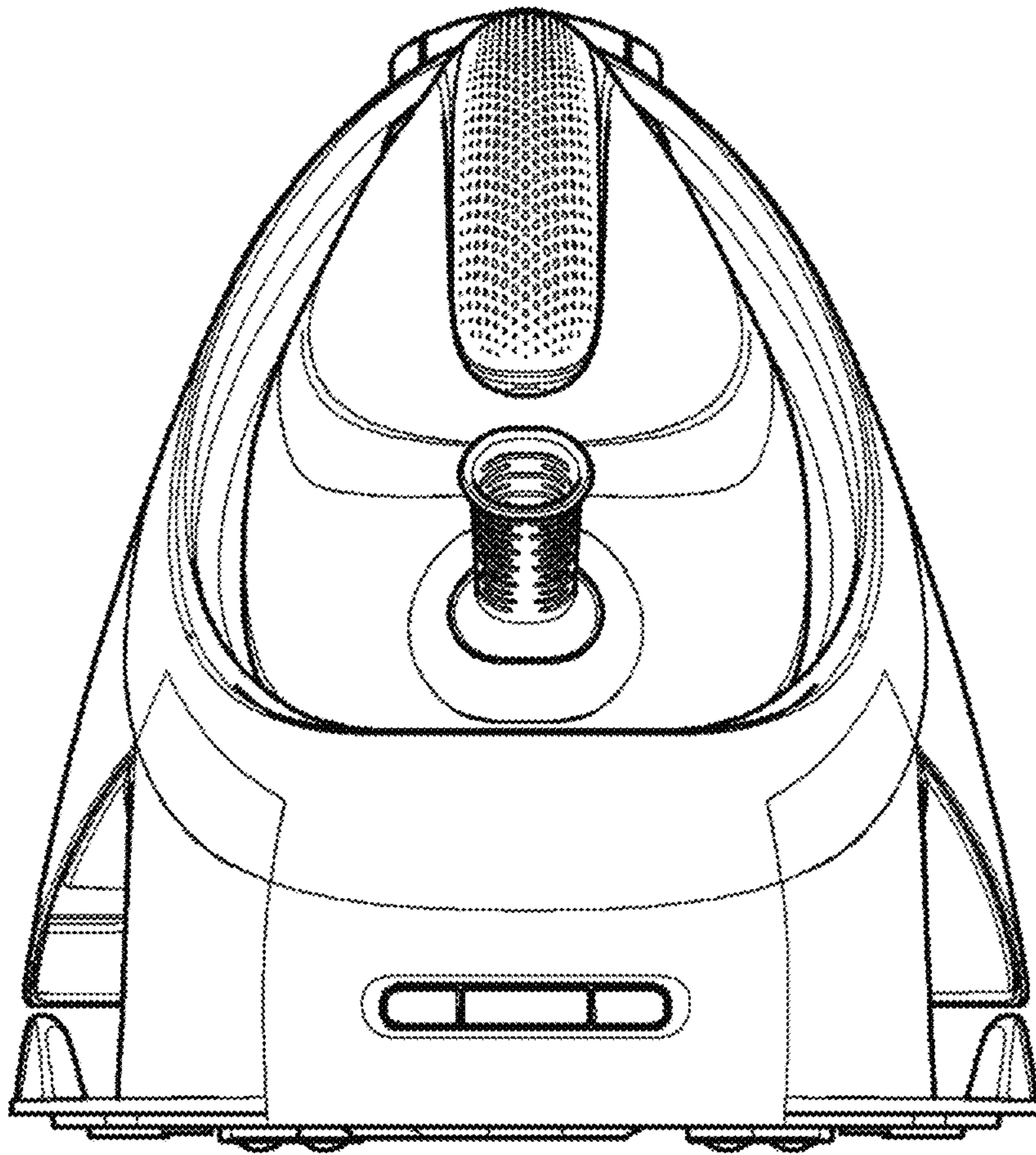

1.3

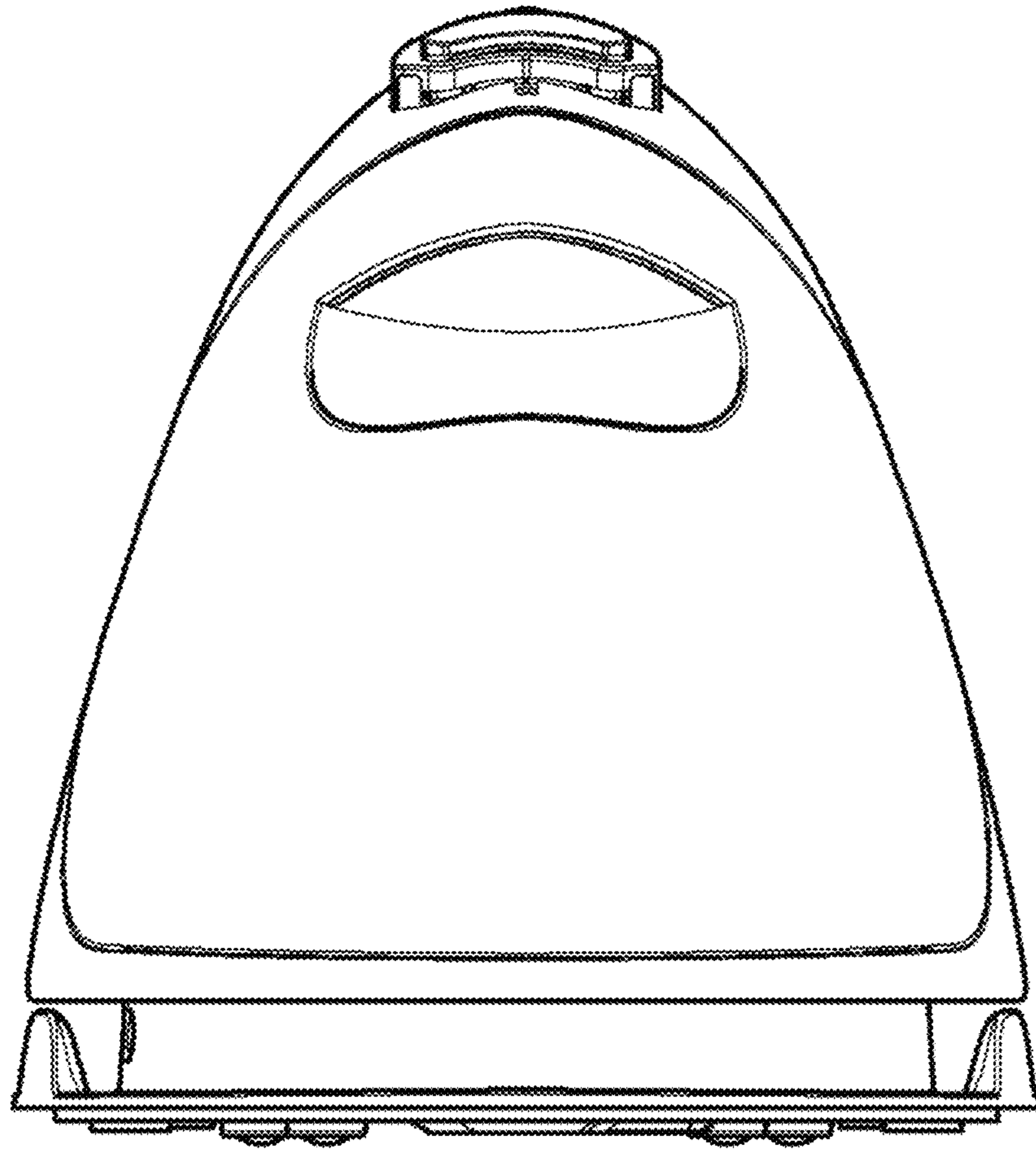

1.4

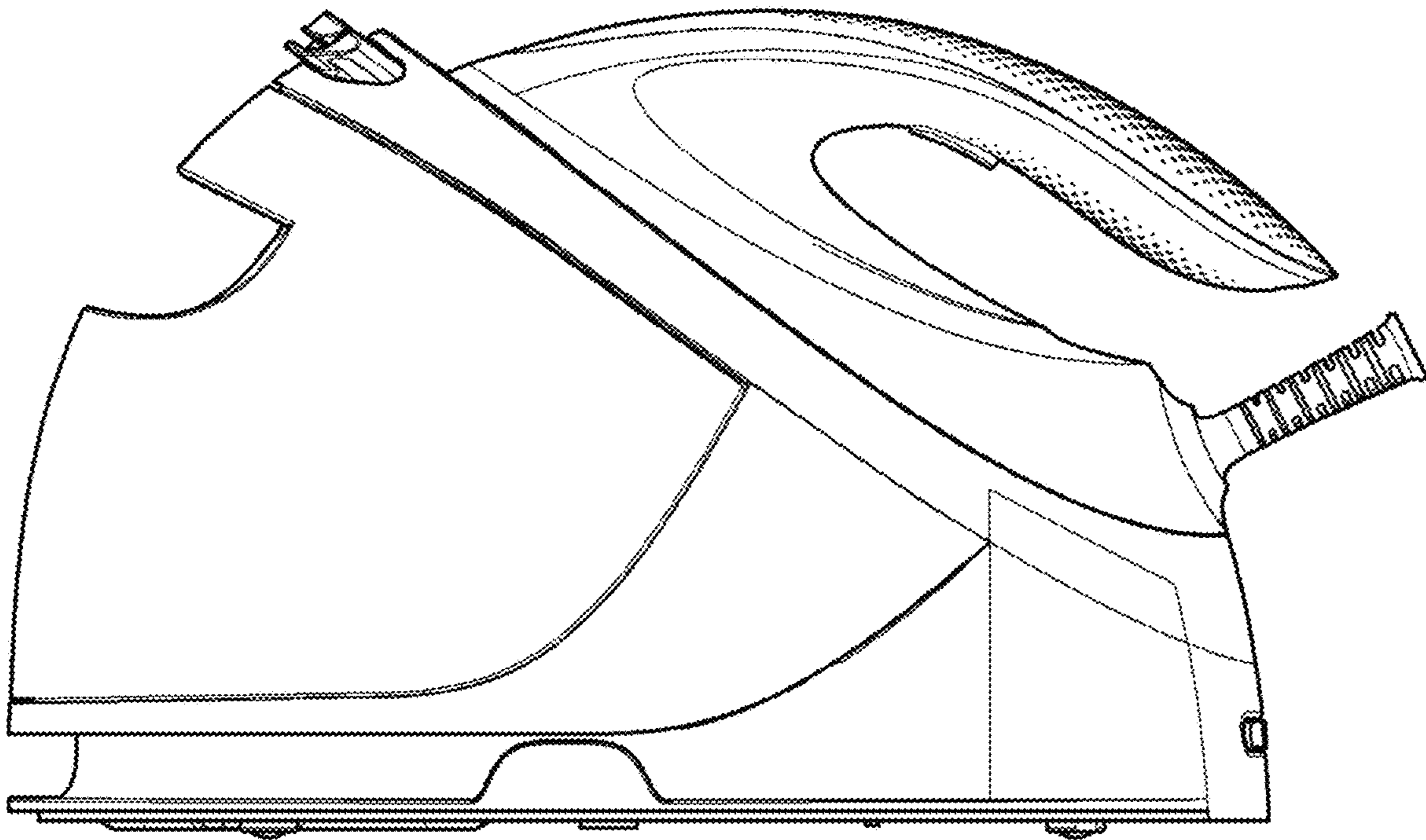

1.5

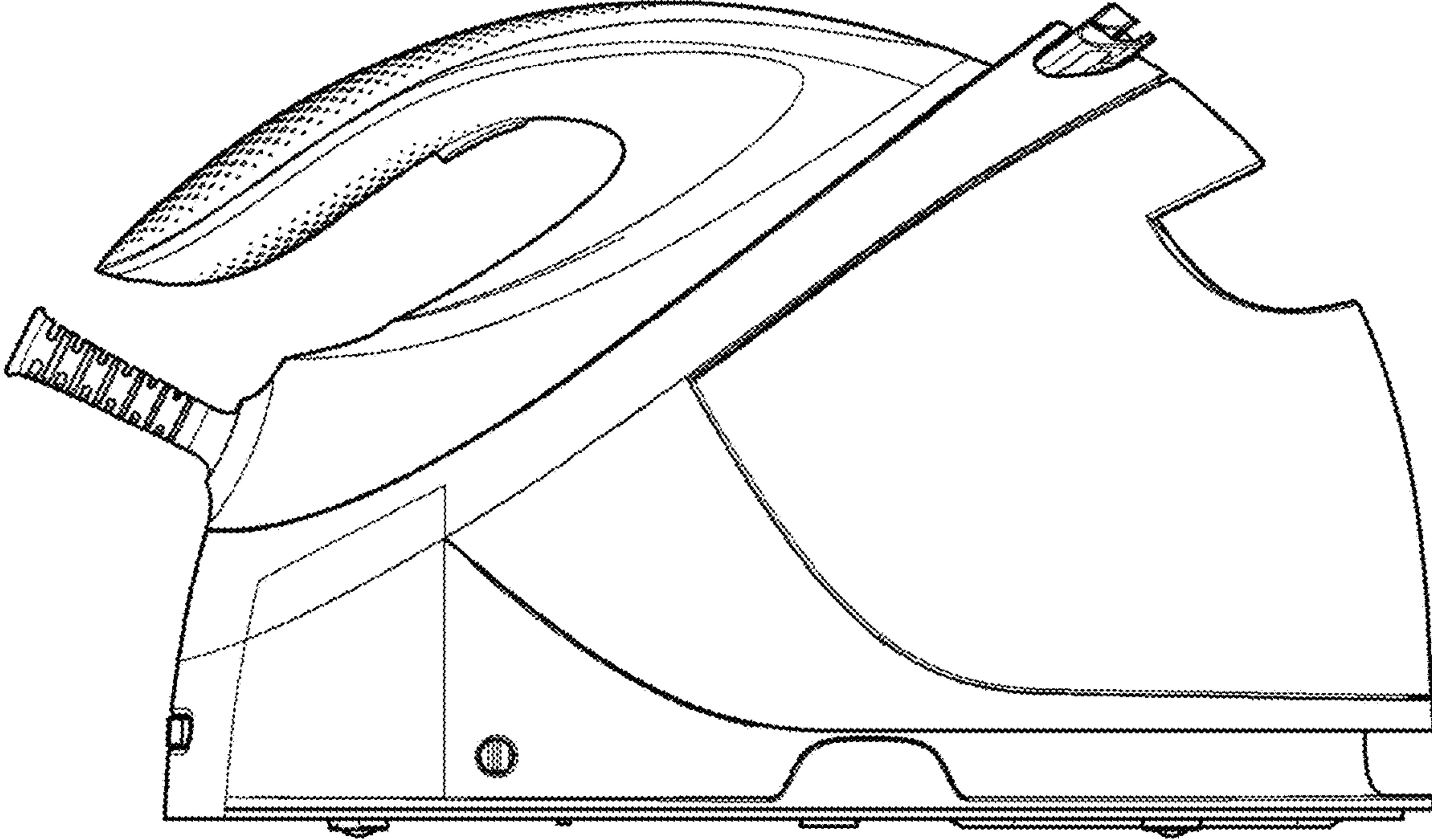

1.6

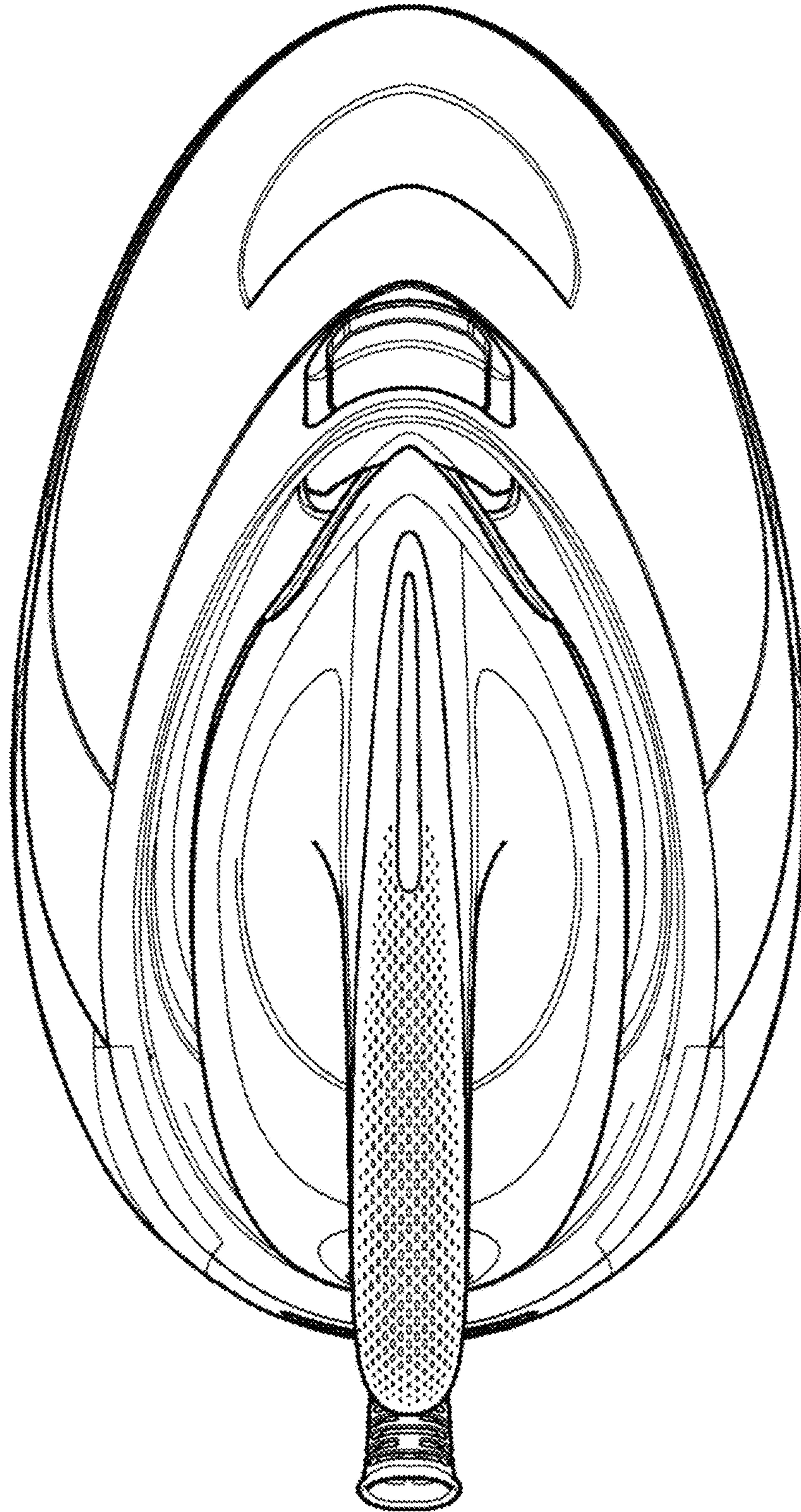

1.7

