

US00D838370S

(12) **United States Design Patent** (10) **Patent No.:** **US D838,370 S**
Bardy et al. (45) **Date of Patent:** **** Jan. 15, 2019**

(54) **ELECTROCARDIOGRAPHY MONITOR**

FOREIGN PATENT DOCUMENTS

(71) Applicant: **Bardy Diagnostics, Inc.**, Vashon, WA (US)

DE 19955211 5/2001
EP 1859833 11/2007

(Continued)

(72) Inventors: **Gust H. Bardy**, Carnation, WA (US);
Jon Mikalson Bishay, Seattle, WA (US)

OTHER PUBLICATIONS

US 6,527,714, 03/2003, Bardy (withdrawn)

(Continued)

(73) Assignee: **Bardy Diagnostics, Inc.**, Seattle, WA (US)

Primary Examiner — Anhdao Doan

(**) Term: **14 Years**

(74) *Attorney, Agent, or Firm* — Patrick J. S. Inouye;
Leonid Kisselev

(21) Appl. No.: **29/509,404**

(57) **CLAIM**

(22) Filed: **Nov. 17, 2014**

The ornamental design for an electrocardiography monitor, as shown and described.

Related U.S. Application Data

DESCRIPTION

(63) Continuation of application No. 29/472,046, filed on Nov. 7, 2013, now Pat. No. Des. 717,955.

FIG. 1 is a perspective view showing an electrocardiography monitor.

(51) **LOC (11) Cl.** **24-02**

FIG. 2 is a top plan view of the electrocardiography monitor.

(52) **U.S. Cl.**

FIG. 3 is a bottom plan view of the electrocardiography monitor.

USPC **D24/167**

FIG. 4 is a front elevational view of the electrocardiography monitor.

(58) **Field of Classification Search**

USPC D24/164–168, 186, 187; D3/203.1; D10/75

FIG. 5 is a rear elevational view of the electrocardiography monitor.

CPC A61B 5/044; A61B 5/0402; A61B 5/0404; A61B 5/04085; A61B 5/0416; A61B 5/6805; A61B 2560/0412; A61B 2560/0462

FIG. 6 is a right elevational view of the electrocardiography monitor.

See application file for complete search history.

FIG. 7 is a left elevational view of the electrocardiography monitor; and,

(56) **References Cited**

FIG. 8 is another perspective view thereof, in which the electrocardiography monitor is shown in an example environment, as shown in broken lines.

U.S. PATENT DOCUMENTS

The broken lines immediately adjacent the claimed surface represent the bounds of the claim, and all other broken lines represent environment; the broken lines form no part of the claimed design.

3,215,136 A 11/1965 Holter et al.
3,425,412 A 2/1969 Pope
3,543,761 A 12/1970 Bradley

(Continued)

1 Claim, 7 Drawing Sheets

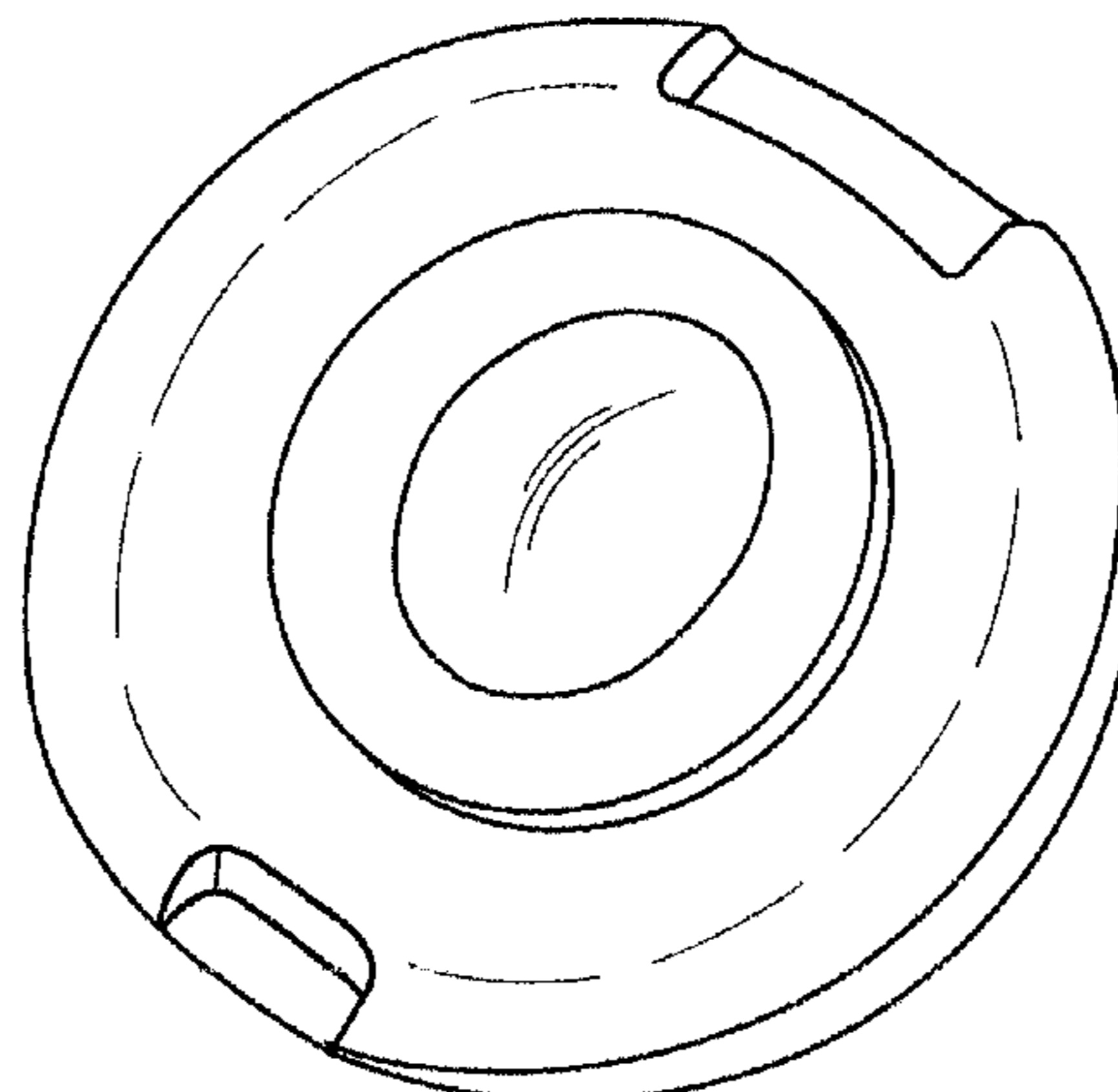

(56)

References Cited

U.S. PATENT DOCUMENTS

D232,590 S	8/1974	Moore	D469,540 S	1/2003	Holker et al.
D240,166 S	6/1976	Cartmell et al.	D471,281 S	3/2003	Baura et al.
D242,954 S	1/1977	Rand	6,546,285 B1	4/2003	Owen et al.
4,123,785 A	10/1978	Cherry et al.	D475,138 S	5/2003	Baura et al.
4,331,153 A	5/1982	Healy	6,605,046 B1	8/2003	Del Mar
4,353,372 A	10/1982	Ayer	6,607,485 B2	8/2003	Bardy
4,524,087 A	6/1985	Engel	6,671,545 B2	12/2003	Fincke
4,532,934 A	8/1985	Kelen	6,671,547 B2	12/2003	Lyster et al.
4,550,502 A	11/1985	Grayzel	6,694,186 B2	2/2004	Bardy
4,616,644 A	10/1986	Saferstein et al.	6,704,595 B2	3/2004	Bardy
4,716,903 A	1/1988	Hansen	6,705,991 B2	3/2004	Bardy
4,809,705 A	3/1989	Ascher	6,747,183 B2	6/2004	Siegwart et al.
4,915,656 A	4/1990	Alferness	6,754,523 B2	6/2004	Toole
4,957,109 A	9/1990	Groeger et al.	D495,055 S	8/2004	Silber
5,042,481 A	8/1991	Suzuki et al.	6,782,293 B2	8/2004	Dupelle et al.
D326,716 S	6/1992	Mortara	6,860,897 B2	3/2005	Bardy
5,168,876 A	12/1992	Quedens et al.	6,866,629 B2	3/2005	Bardy
5,215,098 A	6/1993	Steinhaus	D505,206 S	5/2005	Chastain et al.
D341,423 S	11/1993	Bible	6,887,201 B2	5/2005	Bardy
5,392,784 A	2/1995	Gudaitis	6,893,397 B2	5/2005	Bardy
D357,069 S	4/1995	Plahn et al.	6,904,312 B2	6/2005	Bardy
5,402,780 A	4/1995	Faasse, Jr.	6,908,431 B2	6/2005	Bardy
5,402,884 A	4/1995	Gilman et al.	6,913,577 B2	7/2005	Bardy
5,423,736 A	6/1995	Cartmell et al.	6,944,498 B2	9/2005	Owen et al.
5,458,141 A	10/1995	Neil	6,960,167 B2	11/2005	Bardy
5,473,537 A	12/1995	Glazer et al.	6,967,261 B1	11/2005	Soerens et al.
5,579,919 A	12/1996	Gilman et al.	6,978,169 B1	12/2005	Guerra
5,582,181 A	12/1996	Ruess	6,993,377 B2	1/2006	Flick et al.
D377,983 S	2/1997	Sabri et al.	7,020,508 B2	3/2006	Stivoric et al.
5,623,935 A	4/1997	Faisandier	D519,636 S	4/2006	Okuda et al.
D387,169 S	12/1997	Dunshee et al.	7,027,864 B2	4/2006	Snyder et al.
5,697,955 A	12/1997	Stolte	7,065,401 B2	6/2006	Worden
D389,244 S	1/1998	Dunshee et al.	7,085,601 B1	8/2006	Bardy et al.
D391,639 S	3/1998	Dunshee et al.	7,104,955 B2	9/2006	Bardy
5,749,902 A	5/1998	Olsen et al.	7,134,996 B2	11/2006	Bardy
5,817,151 A	10/1998	Olsen et al.	7,147,600 B2	12/2006	Bardy
D402,371 S	12/1998	Haynes et al.	D536,673 S	2/2007	Silber
5,850,920 A	12/1998	Gilman et al.	7,215,991 B2	5/2007	Besson et al.
D407,159 S	3/1999	Roberg	7,248,916 B2	7/2007	Bardy
5,895,298 A	4/1999	Faupel et al.	7,257,438 B2	8/2007	Kinast
D409,752 S	5/1999	Bishay et al.	D558,352 S	12/2007	Sanfilippo
5,906,583 A	5/1999	Rogel	D558,882 S	1/2008	Brady
5,916,159 A	6/1999	Kelly et al.	7,328,061 B2	2/2008	Rowlandson et al.
5,951,598 A	9/1999	Bishay et al.	D565,183 S	3/2008	Cheng et al.
5,984,102 A	11/1999	Tay	7,412,395 B2	8/2008	Rowlandson et al.
6,033,370 A	3/2000	Reinbold et al.	D597,676 S *	8/2009	Copeland D24/187
D424,699 S	5/2000	Allen	D598,114 S	8/2009	Cryan
D425,203 S	5/2000	Sheehan et al.	D600,352 S	9/2009	Cryan
6,076,003 A	6/2000	Rogel	D606,656 S	12/2009	Kobayashi et al.
D429,337 S	8/2000	Sanfilippo	D609,353 S	2/2010	Cryan
6,101,413 A	8/2000	Olsen et al.	D613,413 S	4/2010	Gonopolskiy et al.
6,115,638 A	9/2000	Groenke	D615,657 S	5/2010	Anderson et al.
6,117,077 A	9/2000	Del Mar et al.	D615,659 S	5/2010	Anderson et al.
D432,656 S	10/2000	Nash et al.	7,756,721 B1	7/2010	Falchuk et al.
6,134,479 A	10/2000	Brewer et al.	7,787,943 B2	8/2010	McDonough
6,141,575 A	10/2000	Price	D625,823 S	10/2010	Schneider et al.
D433,755 S	11/2000	Mastrototaro et al.	7,874,993 B2	1/2011	Bardy
6,148,233 A	11/2000	Owen et al.	7,881,785 B2	2/2011	Nassif et al.
6,191,338 B1	2/2001	Haller	D639,437 S	6/2011	Bishay et al.
D443,063 S	5/2001	Pisani et al.	7,959,574 B2	6/2011	Bardy
6,269,267 B1	7/2001	Bardy et al.	D646,789 S	11/2011	Barth
6,272,385 B1	8/2001	Bishay et al.	8,116,841 B2	2/2012	Bly et al.
6,284,941 B1	9/2001	Cox et al.	D658,768 S	5/2012	Parker, III et al.
6,298,255 B1	10/2001	Cordero et al.	8,200,320 B2	6/2012	Kovacs
6,301,502 B1	10/2001	Owen et al.	D663,849 S	7/2012	McGusty et al.
6,304,773 B1	10/2001	Taylor et al.	D664,456 S *	7/2012	Trine D10/70
6,304,780 B1	10/2001	Owen et al.	8,231,539 B2	7/2012	Bardy
6,304,783 B1	10/2001	Lyster et al.	8,231,540 B2	7/2012	Bardy
6,374,138 B1	4/2002	Owen et al.	8,239,012 B2	8/2012	Felix et al.
D456,907 S	5/2002	Sanfilippo	8,249,686 B2	8/2012	Libbus et al.
D458,376 S	6/2002	Rouns et al.	8,260,414 B2	9/2012	Nassif et al.
6,418,342 B1	7/2002	Owen et al.	8,266,008 B1	9/2012	Siegal et al.
6,427,083 B1	7/2002	Owen et al.	8,277,378 B2	10/2012	Bardy
6,456,872 B1	9/2002	Faisandier	8,285,356 B2	10/2012	Bly et al.
D468,433 S	1/2003	Wagner et al.	8,285,370 B2	10/2012	Felix et al.
			8,308,650 B2	11/2012	Bardy
			8,366,629 B2	2/2013	Bardy
			8,374,688 B2	2/2013	Libbus et al.
			8,386,009 B2	2/2013	Lindberg et al.

(56)

References Cited

U.S. PATENT DOCUMENTS

D679,819	S	4/2013	Peron	2007/0050209	A1	3/2007	Yered
8,412,317	B2	4/2013	Mazar	2007/0078324	A1	4/2007	Wijisiriwardana
8,460,189	B2	6/2013	Libbus et al.	2007/0093719	A1	4/2007	Nichols, Jr. et al.
8,473,047	B2	6/2013	Chakravarthy et al.	2007/0100667	A1	5/2007	Bardy
8,478,418	B2	7/2013	Fahey	2007/0123801	A1	5/2007	Goldberger et al.
8,585,427	B2	11/2013	Ukawa et al.	2007/0136091	A1	6/2007	McTaggart
8,591,430	B2	11/2013	Amurthur et al.	2007/0179357	A1	8/2007	Bardy
8,613,708	B2	12/2013	Bishay et al.	2007/0203415	A1	8/2007	Bardy
8,613,709	B2	12/2013	Bishay et al.	2007/0203423	A1	8/2007	Bardy
8,620,418	B1	12/2013	Andover	2007/0208233	A1	9/2007	Kovacs
8,626,277	B2	1/2014	Felix et al.	2007/0225611	A1	9/2007	Kumar et al.
D702,357	S	4/2014	Vosch et al.	2007/0244405	A1	10/2007	Xue et al.
8,684,925	B2	4/2014	Manicka et al.	2007/0249946	A1	10/2007	Kumar et al.
8,688,190	B2	4/2014	Libbus et al.	2007/0255153	A1	11/2007	Kumar et al.
8,718,752	B2	5/2014	Libbus et al.	2007/0265510	A1	11/2007	Bardy
D707,829	S	6/2014	Chan et al.	2007/0276270	A1	11/2007	Tran
8,744,561	B2	6/2014	Fahey	2007/0293738	A1	12/2007	Bardy
D708,751	S	7/2014	Chan et al.	2007/0293739	A1	12/2007	Bardy
8,774,932	B2	7/2014	Fahey	2007/0293740	A1	12/2007	Bardy
8,790,257	B2	7/2014	Libbus et al.	2007/0293741	A1	12/2007	Bardy
8,790,259	B2	7/2014	Katra et al.	2007/0293772	A1	12/2007	Bardy
8,795,174	B2	8/2014	Manicka et al.	2008/0051668	A1	2/2008	Bardy
8,798,734	B2	8/2014	Kuppuraj et al.	2008/0058661	A1	3/2008	Bardy
8,818,481	B2	8/2014	Bly et al.	2008/0139953	A1	6/2008	Baker et al.
D712,554	S	9/2014	Igwebuike et al.	2008/0194927	A1	8/2008	KenKnight et al.
8,823,490	B2	9/2014	Libbus et al.	2008/0208014	A1	8/2008	KenKnight et al.
D714,942	S *	10/2014	Hwang D24/167	2008/0284599	A1	11/2008	Zdeblick et al.
D717,960	S	11/2014	Einck et al.	2008/0288026	A1	11/2008	Cross et al.
D718,458	S	11/2014	Vosch et al.	2008/0306359	A1	12/2008	Zdeblick et al.
D719,660	S	12/2014	Vosch et al.	2009/0069867	A1	3/2009	KenKnight et al.
D733,888	S *	7/2015	Tuhkanen D24/167	2009/0073991	A1	3/2009	Landrum et al.
D739,942	S *	9/2015	Pernu D24/167	2009/0076336	A1	3/2009	Mazar et al.
D744,109	S *	11/2015	Yoneta D24/186	2009/0076341	A1	3/2009	James et al.
D744,110	S *	11/2015	Kubo D24/186	2009/0076342	A1	3/2009	Amurthur et al.
D745,688	S	12/2015	Chan et al.	2009/0076343	A1	3/2009	James et al.
D745,689	S	12/2015	Chan et al.	2009/0076346	A1	3/2009	James et al.
D748,275	S	1/2016	Vosch et al.	2009/0076349	A1	3/2009	Libbus et al.
D752,764	S	3/2016	Peters	2009/0076397	A1	3/2009	Libbus et al.
D753,525	S *	4/2016	Treadwell D10/106.6	2009/0076401	A1	3/2009	Mazar et al.
D764,060	S *	8/2016	Singh D24/167	2009/0076559	A1	3/2009	Libbus et al.
2002/0013538	A1	1/2002	Teller	2009/0112116	A1	4/2009	Lee et al.
2002/0120310	A1	8/2002	Linder et al.	2009/0216132	A1	8/2009	Orbach
2002/0183605	A1	12/2002	Devlin	2009/0270747	A1	10/2009	Van Dam et al.
2002/0193668	A1	12/2002	Munneke et al.	2009/0292194	A1	11/2009	Libbus et al.
2003/0004547	A1	1/2003	Owen et al.	2010/0022897	A1	1/2010	Parker et al.
2003/0073916	A1	4/2003	Yonce	2010/0056881	A1	3/2010	Libbus et al.
2003/0083559	A1	5/2003	Thompson	2010/0081913	A1	4/2010	Cross et al.
2003/0093024	A1	5/2003	Falleiros	2010/0185063	A1	7/2010	Bardy
2003/0139785	A1	7/2003	Riff et al.	2010/0191154	A1	7/2010	Berger et al.
2004/0002676	A1	1/2004	Sieglwart	2010/0191310	A1	7/2010	Bly
2004/0008123	A1	1/2004	Carrender	2010/0234716	A1	9/2010	Engel
2004/0019288	A1	1/2004	Kinast	2011/0144470	A1	6/2011	Mazar et al.
2004/0034284	A1	2/2004	Aversano et al.	2011/0245711	A1	10/2011	Katra et al.
2004/0049132	A1	3/2004	Barron et al.	2012/0035432	A1	2/2012	Katra et al.
2004/0087836	A1	5/2004	Green et al.	2012/0088998	A1	4/2012	Bardy et al.
2004/0148194	A1	7/2004	Wellons et al.	2012/0088999	A1	4/2012	Bishay et al.
2004/0243435	A1	12/2004	Williams	2012/0089000	A1	4/2012	Bishay et al.
2004/0256453	A1	12/2004	Lammlle	2012/0089001	A1	4/2012	Bishay et al.
2004/0260188	A1	12/2004	Syed et al.	2012/0089037	A1	4/2012	Bishay et al.
2005/0096717	A1	5/2005	Bishay et al.	2012/0089412	A1	4/2012	Bardy et al.
2005/0108055	A1	5/2005	Ott et al.	2012/0089417	A1	4/2012	Bardy et al.
2005/0154267	A1	7/2005	Bardy	2012/0095352	A1	4/2012	Tran
2005/0182308	A1	8/2005	Bardy	2012/0101396	A1	4/2012	Solosko et al.
2005/0182309	A1	8/2005	Bardy	2012/0220975	A1	8/2012	Chan et al.
2005/0228243	A1	10/2005	Bardy	2012/0302906	A1	11/2012	Felix et al.
2005/0245839	A1	11/2005	Stivoric et al.	2013/0079611	A1	3/2013	Besko
2006/0025824	A1	2/2006	Freeman et al.	2013/0096395	A1	4/2013	Katra et al.
2006/0041201	A1	2/2006	Behbehani et al.	2013/0123651	A1	5/2013	Bardy
2006/0058695	A1 *	3/2006	Chen A61B 5/0402 600/509	2013/0158361	A1	6/2013	Bardy
2006/0122469	A1	6/2006	Martel	2013/0274584	A1	10/2013	Finlay et al.
2006/0224072	A1	10/2006	Shennib	2013/0275158	A1	10/2013	Fahey
2006/0235320	A1	10/2006	Tan et al.	2013/0331665	A1	12/2013	Libbus et al.
2006/0253006	A1	11/2006	Bardy	2013/0338448	A1	12/2013	Libbus et al.
2007/0003115	A1	1/2007	Patton et al.	2014/0012154	A1	1/2014	Mazar et al.

(56)

References Cited

U.S. PATENT DOCUMENTS

2014/0142411 A1* 5/2014 Lin A61B 5/04085
600/386

FOREIGN PATENT DOCUMENTS

EP	2465415	6/2012
EP	2589333	5/2013
WO	0078213	12/2000
WO	2003032192	4/2003
WO	2006009767	1/2006
WO	2006014806	2/2006
WO	2007092543	8/2007
WO	2008010216	1/2008
WO	2009036306	3/2009
WO	2009036327	3/2009
WO	2009112976	9/2009
WO	2009112978	9/2009
WO	2009112979	9/2009
WO	2009142975	11/2009
WO	2010066507	6/2010
WO	2011047207	4/2011
WO	2012140559	10/2012
WO	2012146957	11/2012

OTHER PUBLICATIONS

Saadi et al. "Heart Rhythm Analysis Using ECG Recorded With a Novel Sternum Based Patch Technology—A Pilot Study." *Cardio technix 2013—Proceedings of the International Congress on Cardiovascular Technologies*, Sep. 20, 2013.

Anonymous. "Omegawave Launches Consumer App 2.0 in U.S. Endurance Sportswire—Endurance Sportswire." Jul. 11, 2013. URL: <http://endurancesportswire.com/omegawave-launches-consumer-app-2-0-in-u-s/>.

Chan et al. "Wireless Patch Sensor for Remote Monitoring of Heart Rate, Respiration, Activity, and Falls." pp. 6115-6118. 2013 35th Annual International Conference of the IEEE Engineering in Medical and Biology Society. Jul. 1, 2013.

Wei et al. "A Stretchable and Flexible System for Skin-Mounted Measurement of Motion Tracking and Physiological Signals." pp. 5772-5775. 2014 36th Annual International Conference of the IEEE Engineering in Medicine and Biology Society. Aug. 26, 2014.

Daoud et al. "Fall Detection Using Shimmer Technology and Multiresolution Analysis." Aug. 2, 2013. URL: <https://decibel.ni.com/content/docs/DOC-26652>.

Libbus. "Adherent Cardiac Monitor With Wireless Fall Detection for Patients With Unexplained Syncope." Abstracts of the First AMA-IEEE Medical Technology Conference on Individualized Healthcare. May 22, 2010.

15 of the Hottest Wearable Gadgets, URL <http://thehottestgadgets.com/2008/09/the-15-hottest-wearable-gadgets-001253> (Web page cached on Sep. 27, 2008).

Alivecor's Heart Monitor for iPhone Receives FDA Clearance, URL <http://www.businesswire.com/news/home/20121203005545/en/AliveCor%E2%80%99s-Heart-Monitor-iPhone-Receives-FDA-Clearance#.U7rtq7FVtyF> (Dec. 3, 2012).

Bharadwaj et al., Techniques for Accurate ECG signal processing, *EE Times*, URL www.eetimes.com/document.asp?doc_id=1278571 (Feb. 14, 2011).

Chen et al., "Monitoring Body Temperature of Newborn Infants At Neonatal Intensive Care Units Using Wearable Sensors," *BodyNets 2010*, Corfu Island, Greece. (Sep. 10, 2010).

Epstein, Andrew E. et al.; ACC/AHA/HRS 2008 Guidelines for Device-Based Therapy of Cardiac Rhythm Abnormalities. *J. Am. Coll. Cardiol.* 2008; 51; e1-e62, 66 Pgs.

Fitbit automatically tracks your fitness and sleep, URL <http://www.fitbit.com/> (Web page cached on Sep. 10, 2008).

Smith, Kevin, "Jawbone Up VS. Fitbit Flex: Which Is The Best Fitness Band?" URL <http://www.businessinsider.com/fitbit-flex-vs-jawbone-up-2013-5?op=1> (Jun. 1, 2013).

Kligfield, Paul et al., Recommendations for the Standardization and Interpretation of the Electrocardiogram: Part I. *J. Am. Coll. Cardiol.* 2007; 49; 1109-27, 75 Pgs.

Lauren Gravitz, "When Your Diet Needs a Band-Aid," *Technology Review*, MIT. (May 1, 2009).

Lieberman, Jonathan, "How Telemedicine Is Aiding Prompt ECG Diagnosis in Primary Care," *British Journal of Community Nursing*, vol. 13, No. 3, Mar. 1, 2008 (Mar. 1, 2008), pp. 123-126, XP009155082, ISSN: 1462-4753.

McManus et al., "A Novel Application for the Detection of an Irregular Pulse using an iPhone 4S in Patients with Atrial Fibrillation," vol. 10(3), pp. 315-319 (Mar. 2013).

Nike+ Fuel Band, URL http://www.nike.com/us/en_us/c/nikeplus-fuelband (Web page cached on Jan. 11, 2013).

P. Libby et al., "Braunwald's Heart Disease—A Textbook of Cardiovascular Medicine," Chs. 11, pp. 125-148 and 12, pp. 149-193 (8th ed. 2008), American Heart Association.

Initial hands-on with Polar Loop activity tracker, URL <http://www.dcrainmaker.com/2013/09/polar-loop-firstlook.html> (Sep. 17, 2013).

Sittig et al., "A Computer-Based Outpatient Clinical Referral System," *International Journal of Medical Informatics*, Shannon, IR, vol. 55, No. 2, Aug. 1, 1999, pp. 149-158, XO004262434, ISSN: 1386-5056(99)00027-1.

Sleepview, URL <http://www.clevemed.com/sleepview/overview.shtml> (Web pages cached on Feb. 23, 2010, Dec. 29, 2012 and Sep. 4, 2013).

Actigraphy/ Circadian Rhythm SOMNOwatch, URL <http://www.somnomedics.eu/news-events/publications/somnowatchtm.html> (Web page cached on Jan. 23, 2010).

Zio Event Card, URL <http://www.irhythmtech.com/zio-solution/zio-event/> (Web page cached on Mar. 11, 2013).

Zio Patch System, URL <http://www.irhythmtech.com/zio-solution/zio-system/index.html> (Web page cached on Sep. 8, 2013).

Seifert, Dan, "Samsung dives into fitness wearable with the Gear Fit/ The Verge," URL <http://www.theverge.com/2014/2/24/5440310/samsung-dives-into-fitness-wearables-with-the-gear-fit> (Feb. 24, 2014).

Soper, Taylor, "Samsung's new Galaxy S5 flagship phone has fingerprint reader, heart rate monitor," URL <http://www.geekwire.com/2014/samsung-galaxy-s5-fingerprint/> (Feb. 24, 2014).

Dolcourt, Jessica, "See the Samsung Galaxy S5's Heart rate monitor in action," URL <http://www.cnet.com/news/see-the-samsung-galaxy-s5s-heart-rate-monitor-in-action/> (Feb. 25, 2014).

* cited by examiner

Fig. 1.

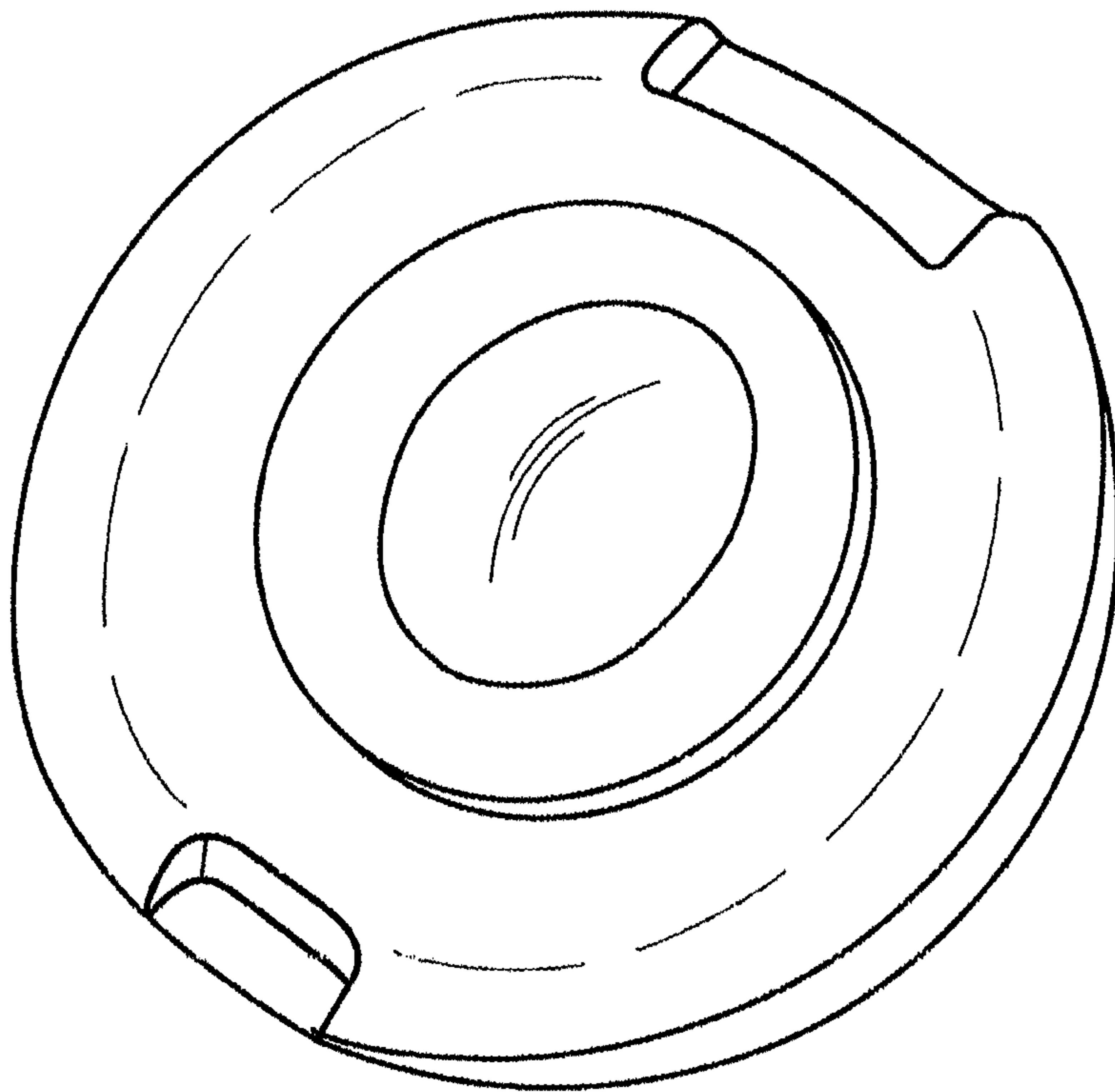

Fig. 2.

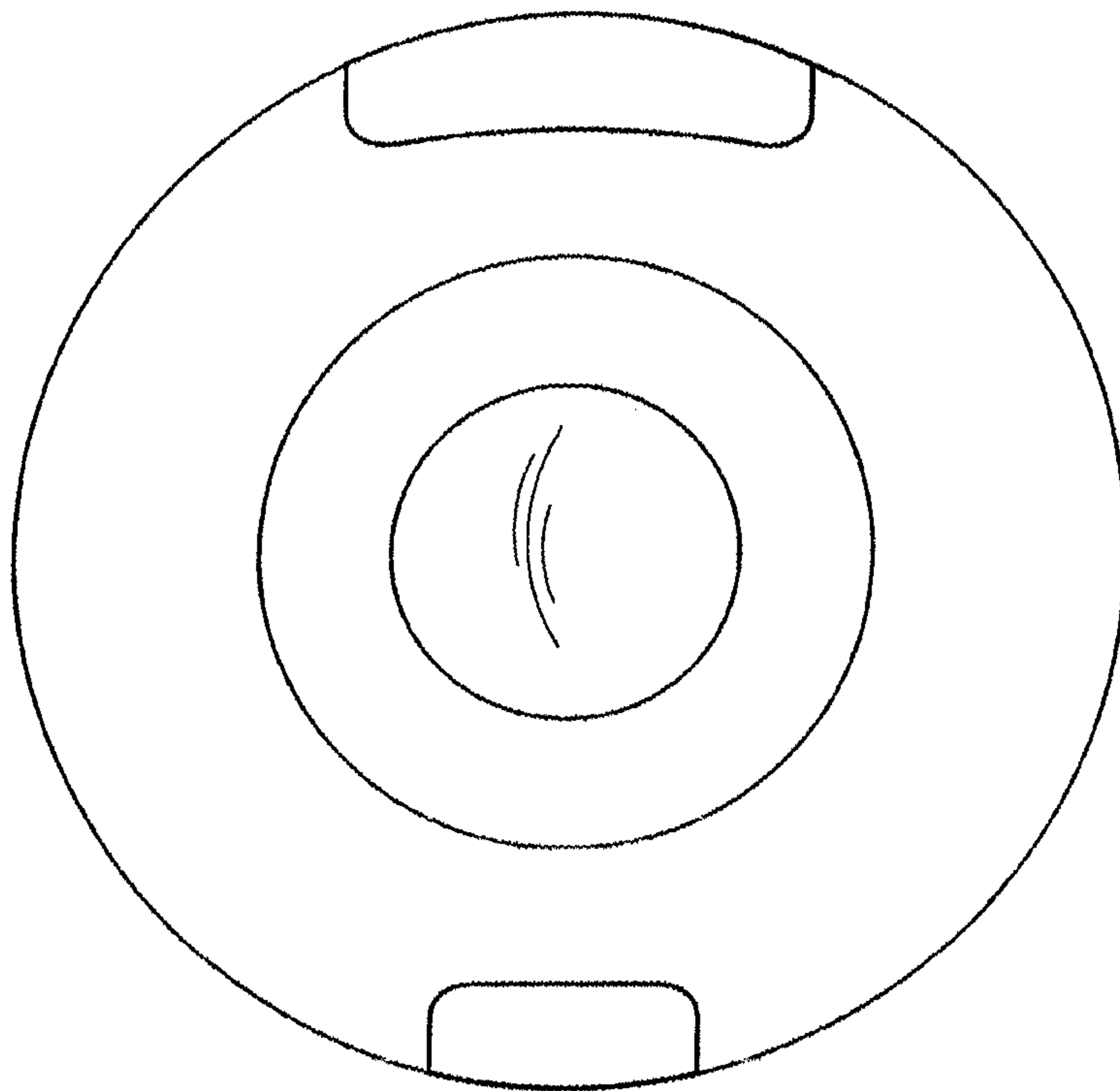

Fig. 3.

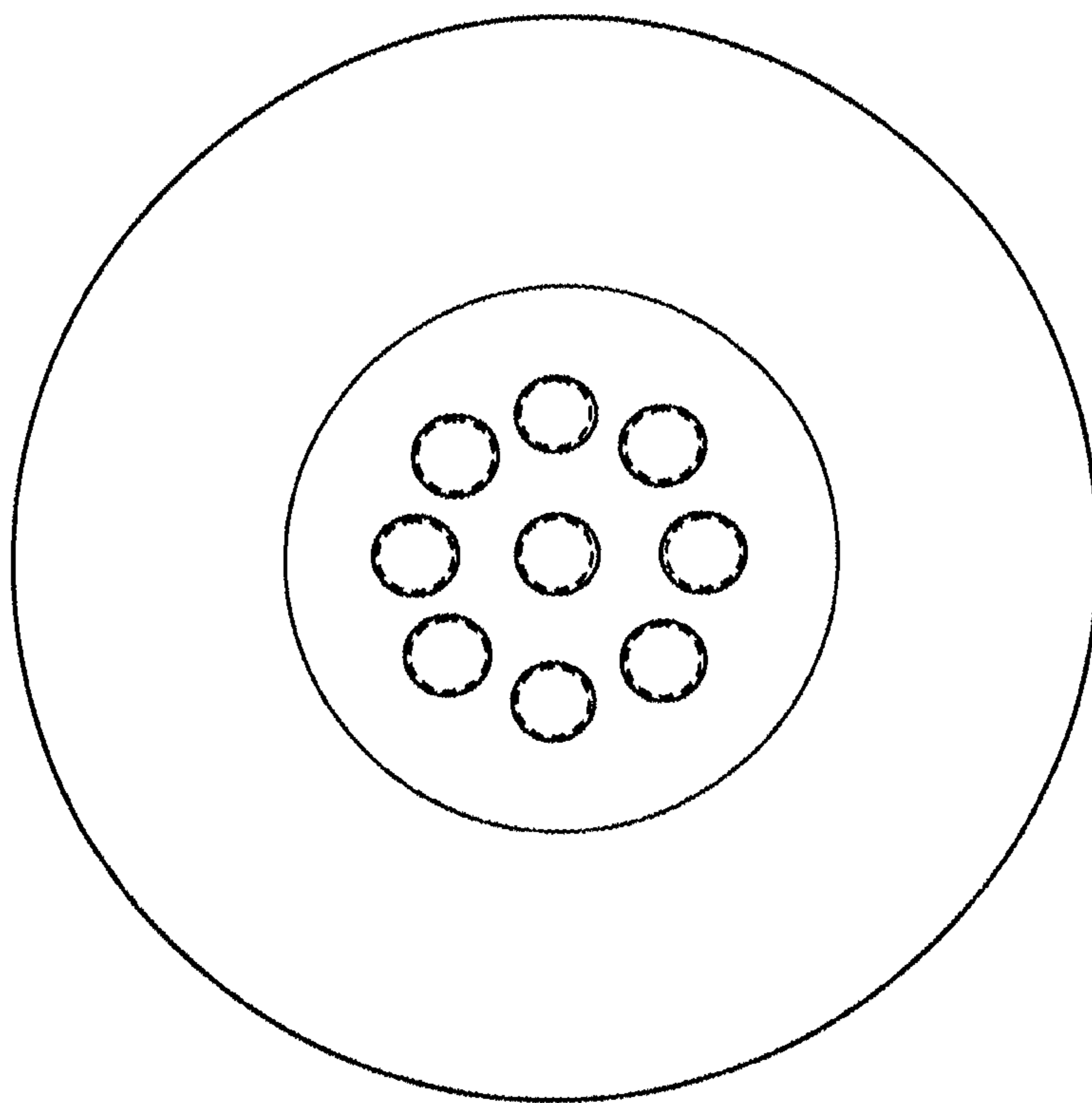

Fig. 4.

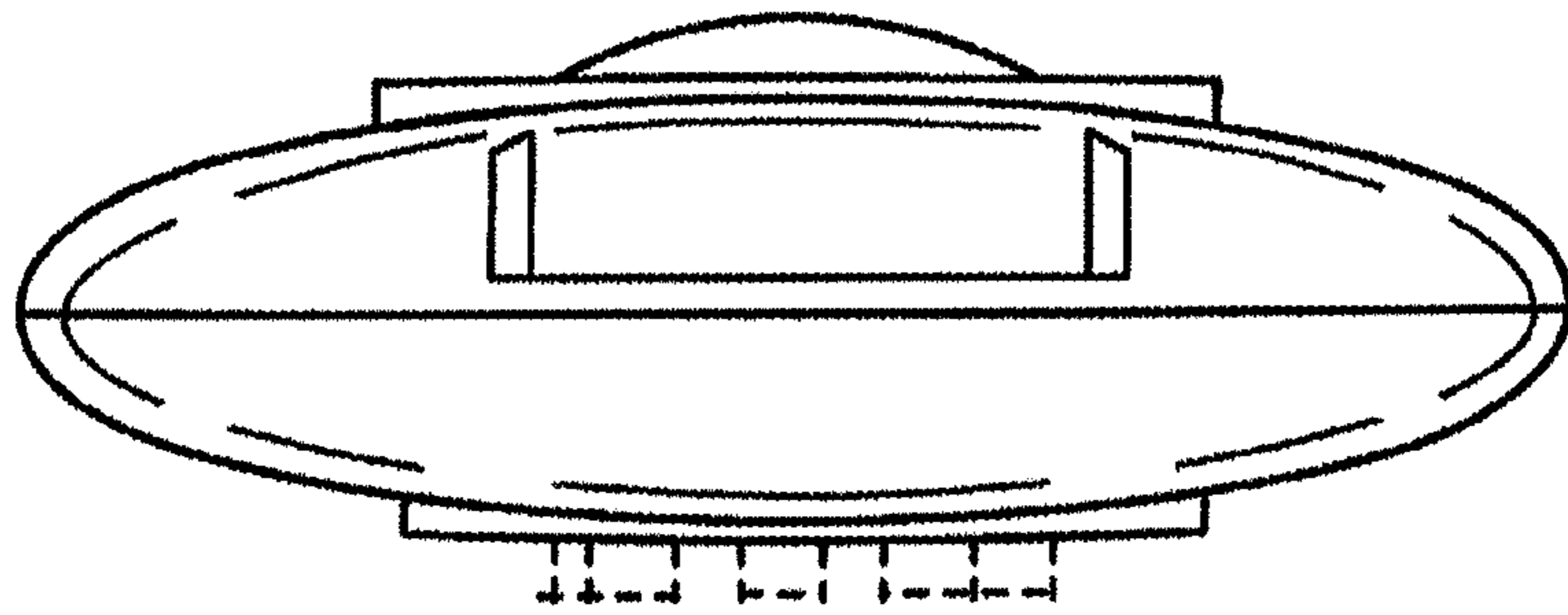

Fig. 5.

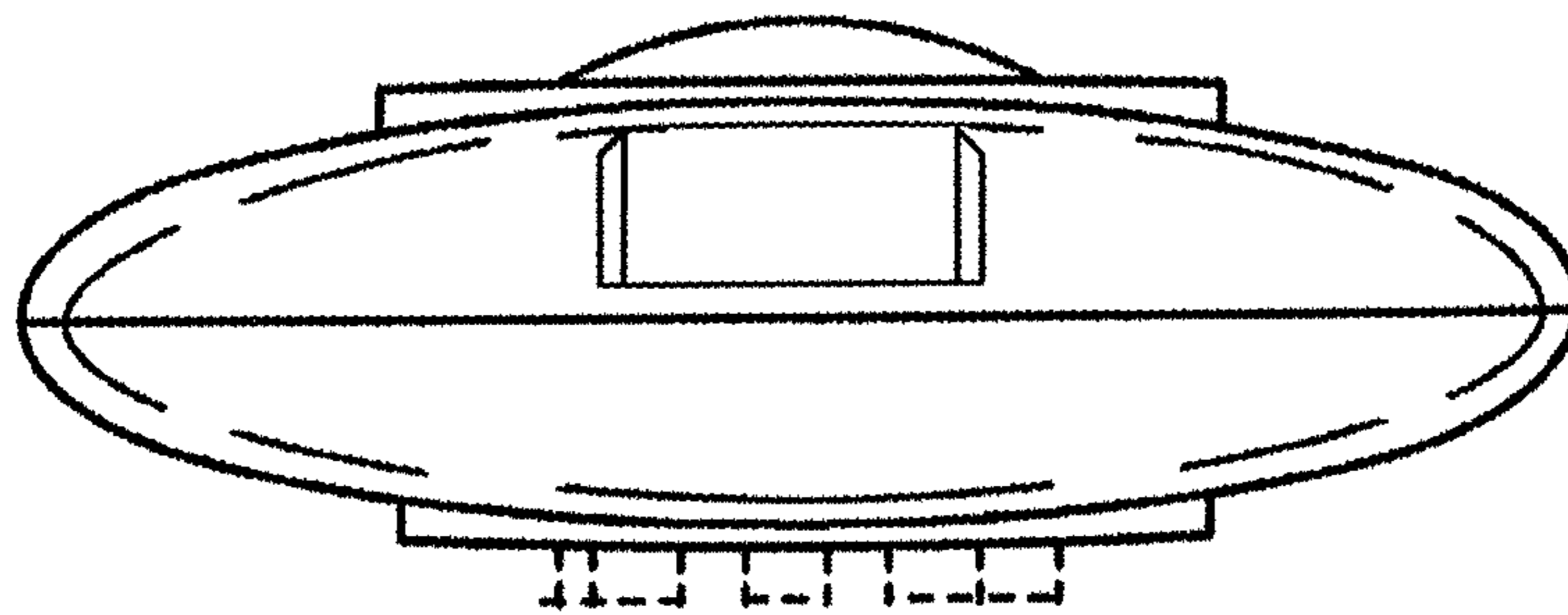

Fig. 6.

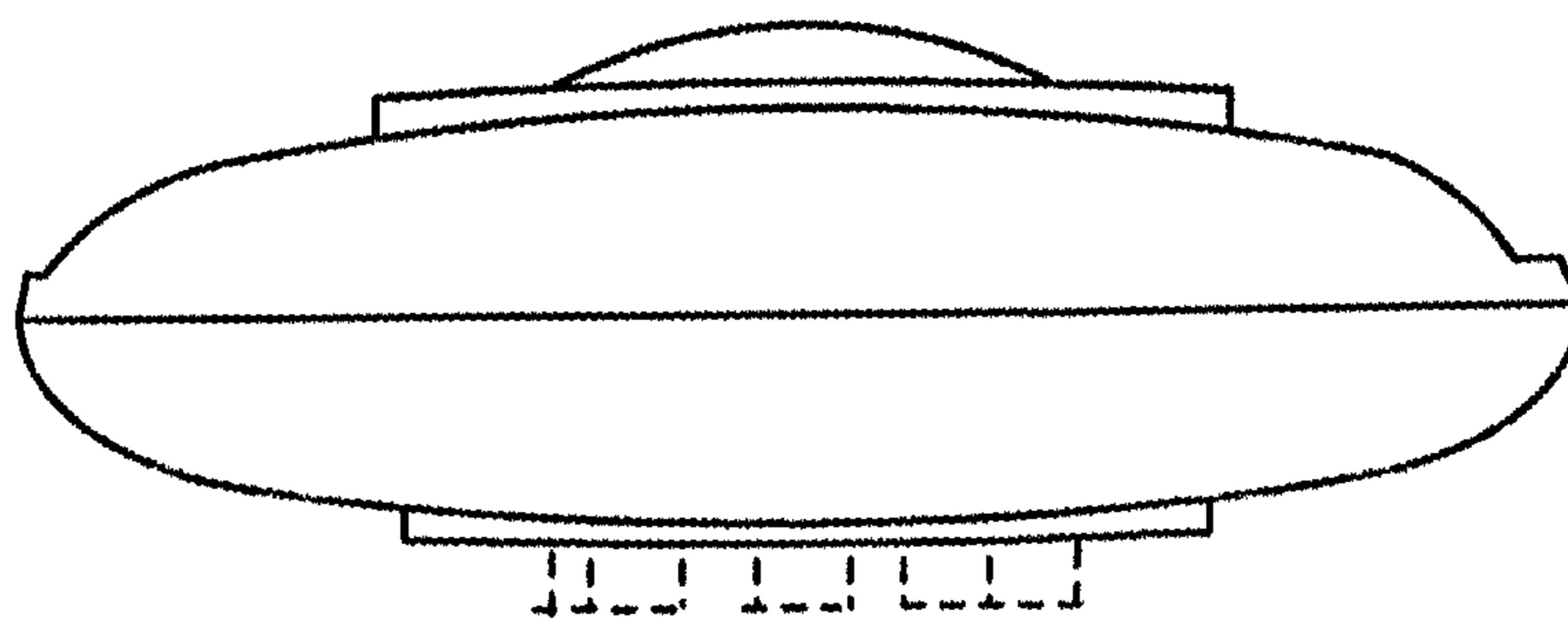

Fig. 7.

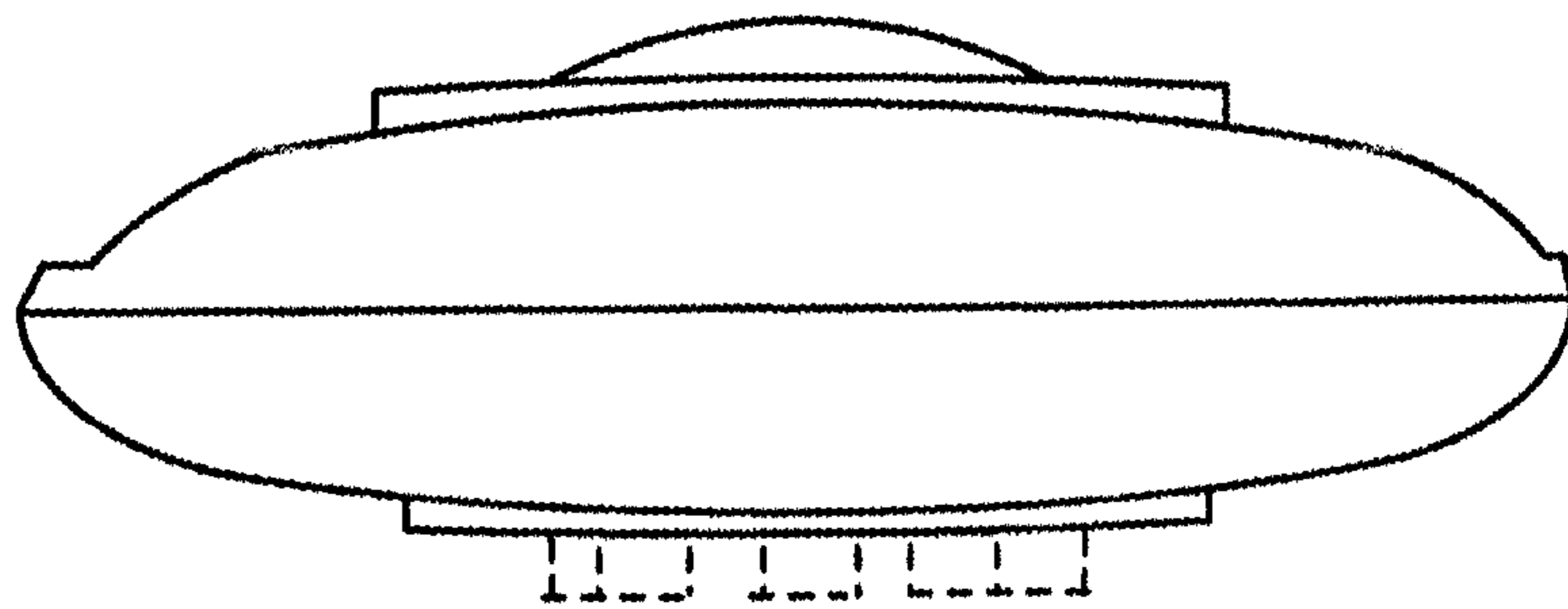

Fig. 8.

