



US00D838220S

(12) **United States Design Patent** (10) **Patent No.:** **US D838,220 S**  
**Anderson et al.** (45) **Date of Patent:** **\*\* Jan. 15, 2019**

(54) **BODY PART FOR VEHICLE**  
(71) Applicant: **Volvo Lastvagnar AB**, Göteborg (SE)  
(72) Inventors: **Ian Anderson**, Greensboro, NC (US);  
**Jeff Cotner**, Greensboro, NC (US)  
(73) Assignee: **VOLVO LASTVAGNAR AB**,  
Gothenburg (SE)  
(\*\*) Term: **15 Years**  
(21) Appl. No.: **29/600,068**  
(22) Filed: **Apr. 10, 2017**  
(51) **LOC (11) Cl.** ..... **12-16**  
(52) **U.S. Cl.**  
USPC ..... **D12/196**  
(58) **Field of Classification Search**  
USPC ..... D12/86, 88, 90, 91, 93, 97, 173, 181,  
D12/196, 400; 296/191, 180.1, 180.3;  
280/727, 770; 180/89.12  
CPC ..... B62D 25/00; B62D 25/02; B62D 35/00;  
B62D 35/001; B62D 33/06; B62D  
33/0612  
See application file for complete search history.

(56) **References Cited**  
U.S. PATENT DOCUMENTS  
D395,848 S \* 7/1998 Meryman ..... D12/97  
D434,348 S \* 11/2000 Delashaw ..... D12/96  
D460,023 S \* 7/2002 Beigel ..... D12/96  
D496,620 S \* 9/2004 Perfetti ..... D12/196  
D522,426 S \* 6/2006 Beigel ..... D12/196  
D522,944 S \* 6/2006 Beigel ..... D12/196  
D522,945 S \* 6/2006 Beigel ..... D12/196  
D531,946 S \* 11/2006 Angelo ..... D12/196  
D549,144 S \* 8/2007 Elliott ..... D12/196

D558,643 S \* 1/2008 Beigel ..... D12/96  
D579,843 S \* 11/2008 Beigel ..... D12/196  
D628,134 S \* 11/2010 Salnick ..... D12/196  
D708,105 S \* 7/2014 Leetz ..... D12/196  
D711,788 S \* 8/2014 Brzustowicz ..... D12/96  
D719,879 S \* 12/2014 Ito ..... D12/96  
9,139,241 B1 \* 9/2015 Smith ..... B62D 35/008  
D758,253 S \* 6/2016 Brzustowicz ..... D12/96  
D786,762 S \* 5/2017 Smith ..... D12/196

**OTHER PUBLICATIONS**

Images of Volvo VNL Truck, released 2002, 2 pages.  
\* cited by examiner

*Primary Examiner* — Ian Simmons  
*Assistant Examiner* — Yolanda Robinson  
(74) *Attorney, Agent, or Firm* — Tucker Ellis LLP

(57) **CLAIM**  
The ornamental design for a body part for vehicle, as shown and described.

**DESCRIPTION**

FIG. 1 is a perspective view of a body part for vehicle showing our new design;  
FIG. 2 is a front view thereof;  
FIG. 3 is a left side view thereof shown in enlarged scale;  
FIG. 4 is a right side view thereof;  
FIG. 5 is a top view thereof shown in the scale of FIG. 2; and,  
FIG. 6 is a bottom view thereof.  
The de-emphasized portions shown in the drawings that are surrounded by broken lines are for the purpose of illustrating portions of the body part for vehicle and form no part of the claimed design.

**1 Claim, 4 Drawing Sheets**

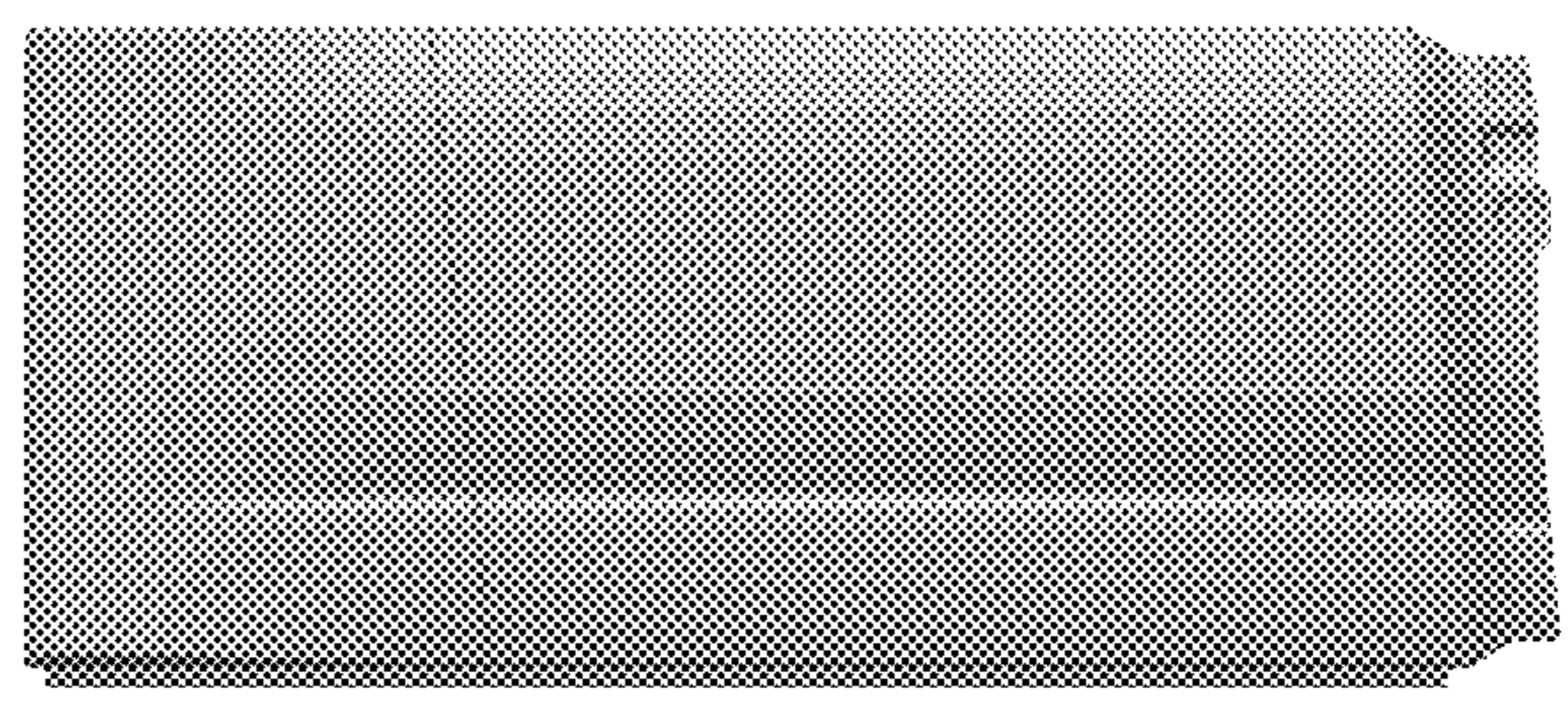
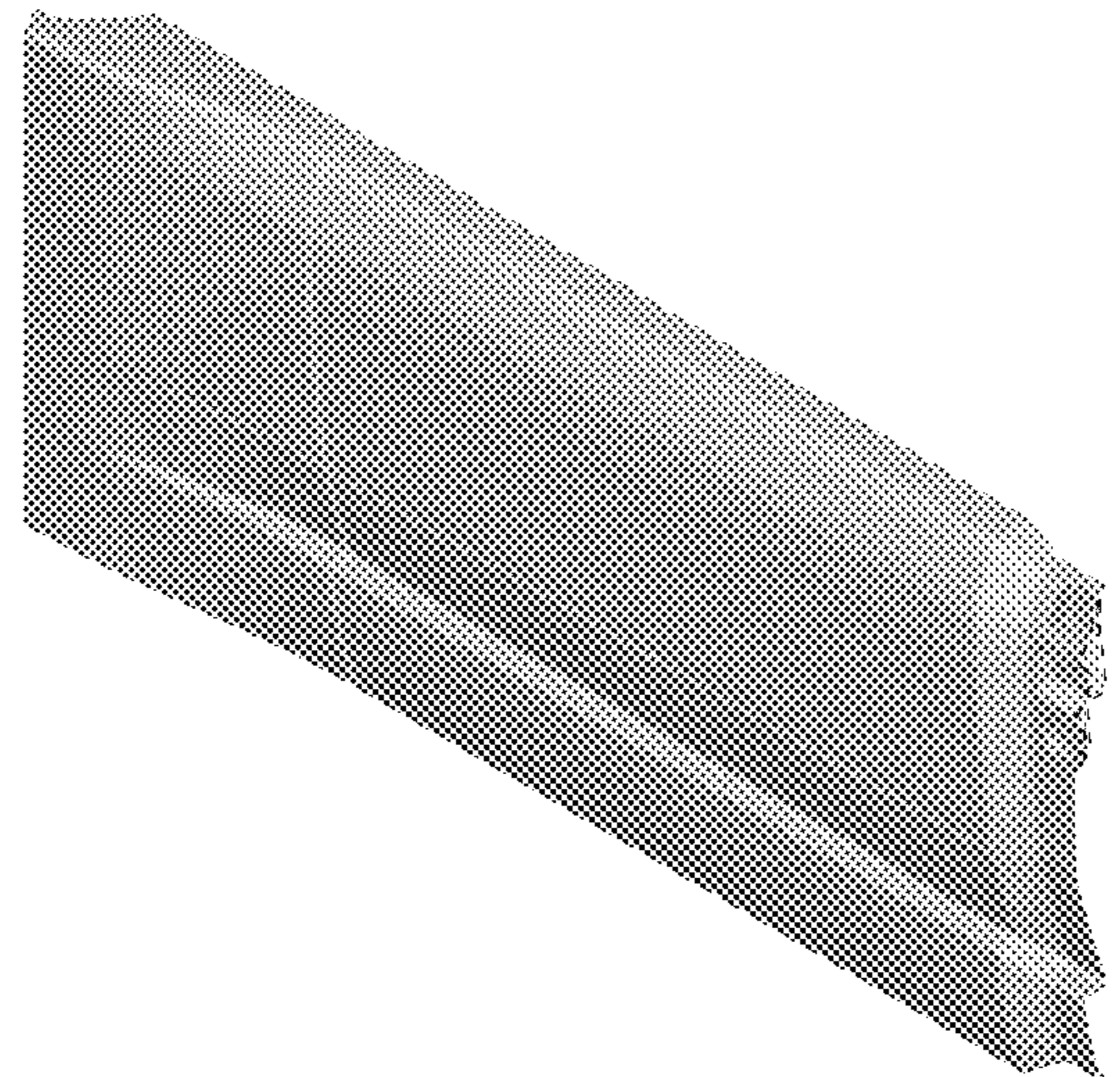

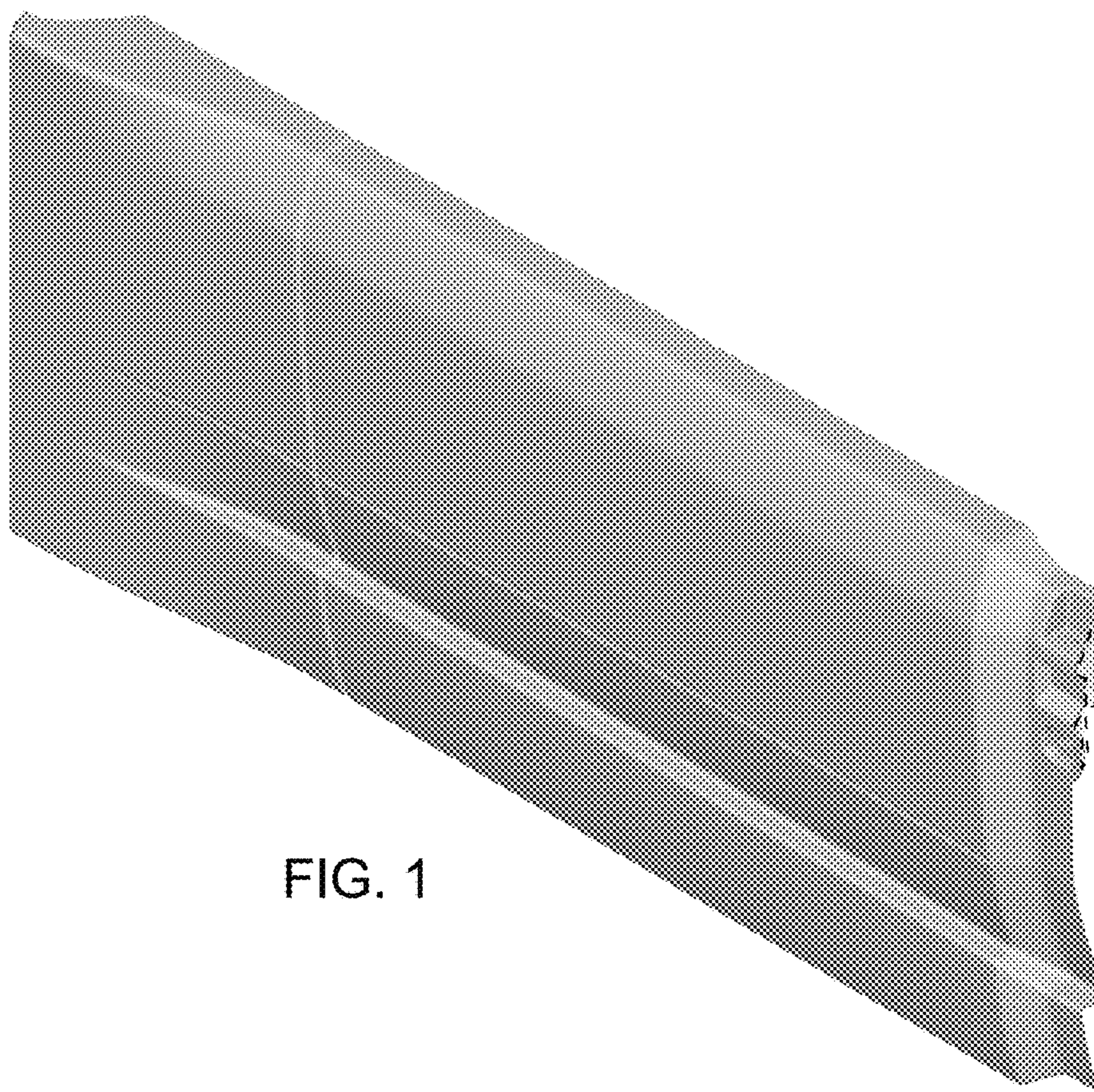

FIG. 1

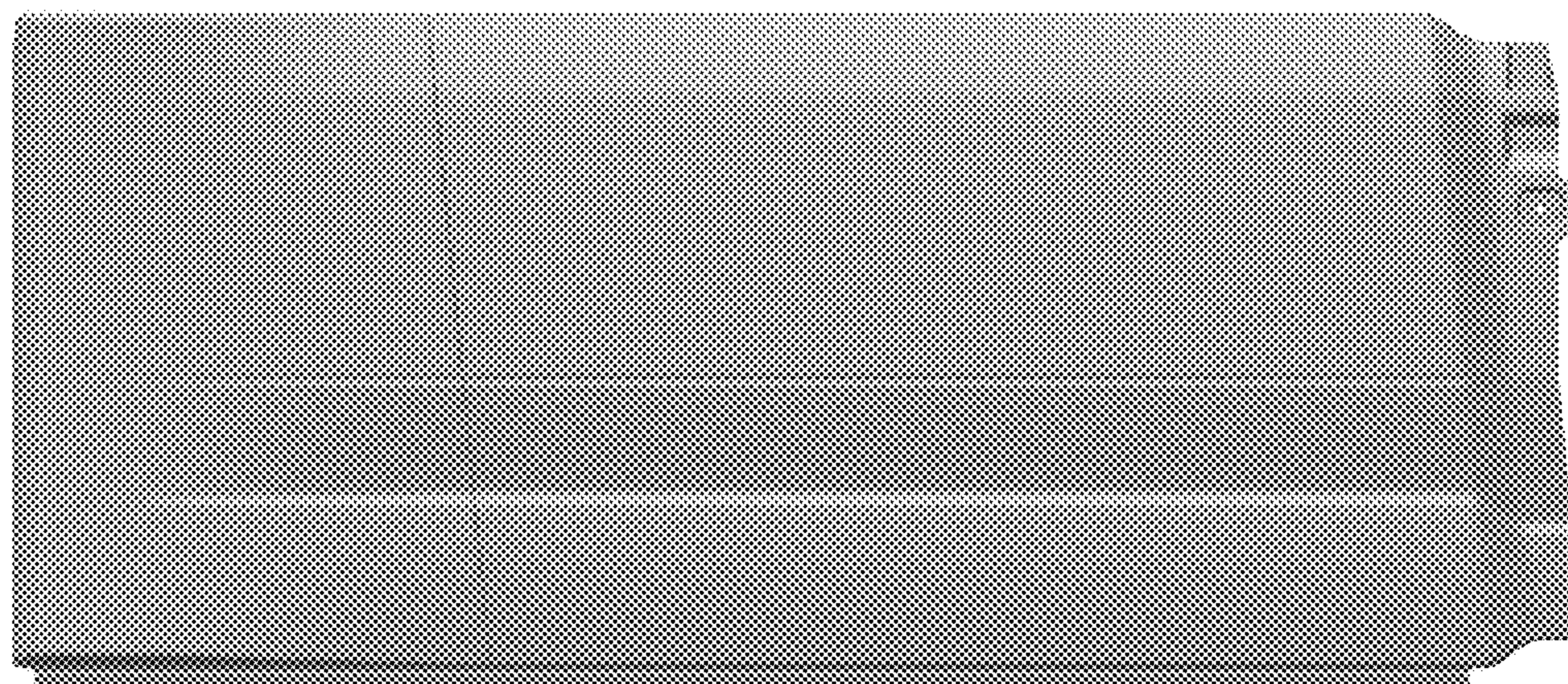

FIG. 2

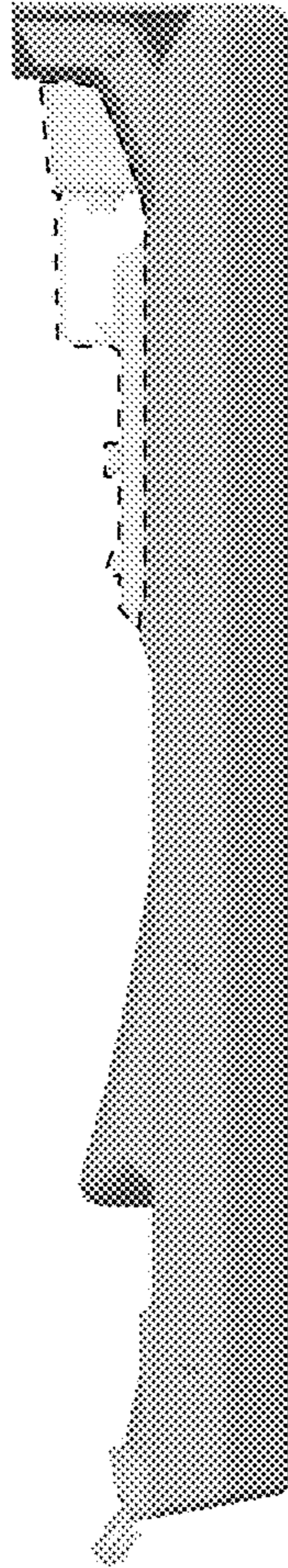

FIG. 3

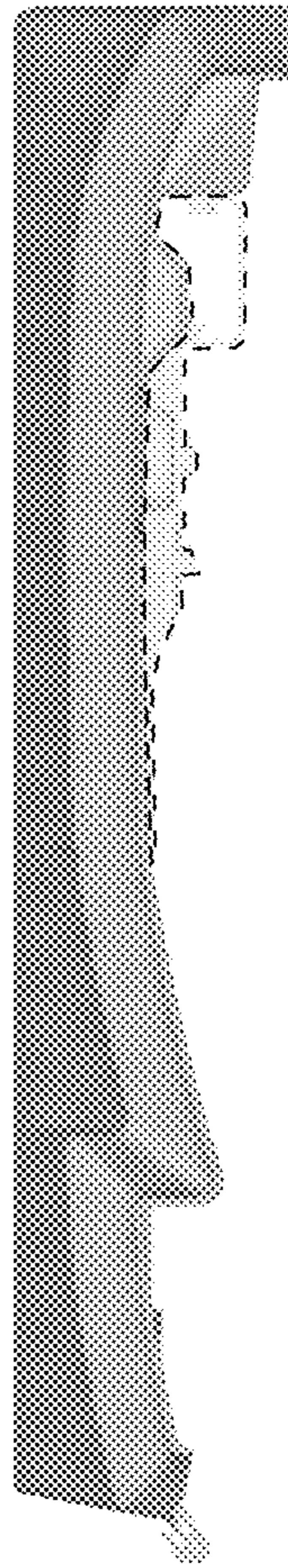

FIG. 4



FIG. 5



FIG. 6